

Features

- Supports Intel CK-MNG specifications
- One CPU differential clock pair
- Individual tristate control and power down functions
- High PPM accuracy
- Spread Spectrum support for EMI reduction
- 3.3 Volt Power Supply
- 40-pin QFN Package

Output Summary

- 1 - differential 96MHz clock output @ 0.7V
- 1 - differential 133MHz clock output @ 0.7V
- 2 - single-ended 25MHz clock outputs @ 3.3V
- 8 - single-ended 50MHz clock output @ 3.3V
- 1 - single-ended 32.7KHz output
- 1 - single-ended 33.3MHz output
- 25Mhz crystal input

The SLG84502 clock synthesizer is a single-chip clock solution intended to be a low-cost high performance platform clocking solution. The SLG84502 synthesizes and distributes a multitude of clock outputs at various frequencies, timings and drive levels using a single 25MHz crystal. The SLG84502 serves as the base clocking component for 133MHz, Video, RMII and other miscellaneous clocks.

CPU Frequency Table

CPU FS2	CPU FS1	CPU FS0	CPUCLK MHz
Byte0 Bit2	Byte0 Bit1	Byte0 Bit0	
0	0	0	266.67
0	0	1	133.33
0	1	0	200.00
0	1	1	166.67
1	0	0	333.33
1	0	1	100.00
1	1	0	400.00
1	1	1	Reserved

SMBus Address Selection

SMBADR	
*SMBADR = 0	SMBADR = 1
D ₀ /D ₁	C ₀ /C ₁

* Default Value

Pin Configuration

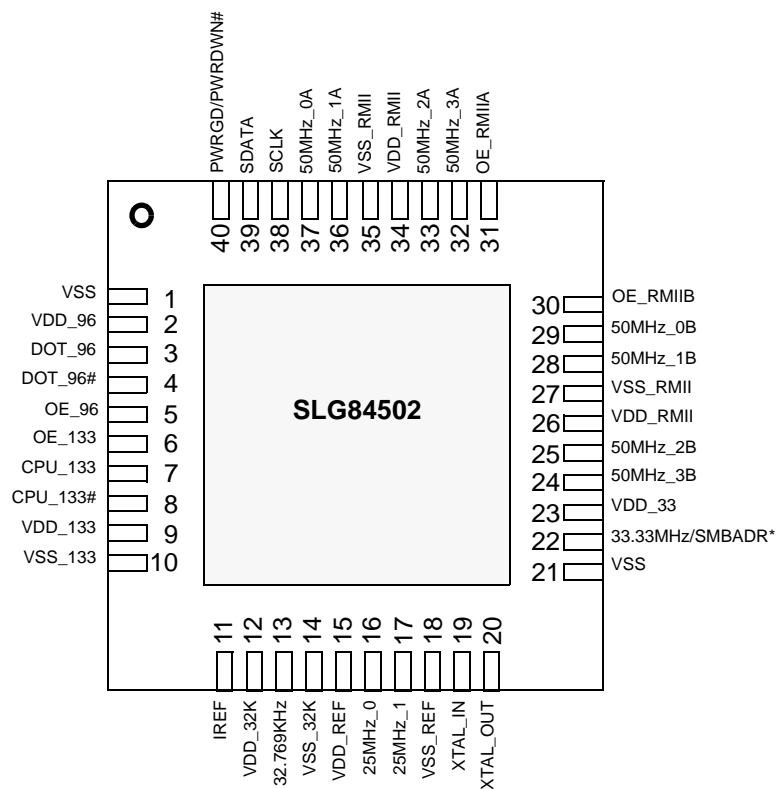

Note: * Internal Pull-Down Resistor - Default

**Pin Description**

Pin #	Name	Type	Description
1	VSS	GND	Ground for outputs.
2	VDD_96	PWR	3.3V power supply for outputs.
3	DOT_96	O, DIF	96MHz differential clock outputs
4	DOT_96#	O, DIF	96MHz differential clock outputs
5	OE_96	I	Active high input for enabling 96MHz outputs. 1 = enable outputs, 0 = tri-state outputs
6	OE_133	I	Active high input for enabling 133MHz outputs. 1 = enable outputs, 0 = tri-state outputs
7	CPU_133	O, DIF	133MHz differential clock outputs
8	CPU_133#	O, DIF	133MHz differential clock outputs
9	VDD_133	PWR	3.3V power supply for outputs.
10	VSS_133	GND	Ground for outputs.
11	IREF	I	A precision resistor is attached to this pin, which is connected to the internal current reference.
12	VDD_32K	PWR	3.3V power supply for outputs.
13	32.769KHz	O, SE	32.769KHz clock
14	VSS_32K	GND	Ground for outputs.
15	VDD_REF	PWR	3.3V power supply for outputs.
16	25MHz_0	O, SE	25MHz clock output
17	25MHz_1	O, SE	25MHz clock output
18	VSS_REF	GND	Ground for outputs.
19	XTAL_IN	I	25MHz crystal input
20	XTAL_OUT	O, SE	25MHz crystal output
21	VSS	GND	Ground for outputs.
22	33.33MHz/SMBADR	I/O	33.33MHz clock output/SMBus address select bit
23	VDD_33	PWR	3.3V power supply for outputs.
24	50MHz_3B	O, SE	50MHz RMII clocks, group B
25	50MHz_2B	O, SE	50MHz RMII clocks, group B
26	VDD_RMII	PWR	3.3V power supply for outputs.
27	VSS_RMII	GND	Ground for outputs.
28	50MHz_1B	O, SE	50MHz RMII clocks, group B
29	50MHz_0B	O, SE	50MHz RMII clocks, group B
30	OE_RMII B	I	Active high input for enabling 50MHz RMII_[3B:0B] outputs 1 = enable outputs, 0 = low
31	OE_RMII A	I	Active high input for enabling 50MHz RMII_[3A:0A] outputs 1 = enable outputs, 0 = low
32	50MHz_3A	O, SE	50MHz RMII clocks, group A
33	50MHz_2A	O, SE	50MHz RMII clocks, group A

**Pin Description** (continued)

Pin #	Name	Type	Description
34	VDD_RMII	PWR	3.3V power supply for outputs.
35	VSS_RMII	GND	Ground for outputs.
36	50MHz_1A	O, SE	50MHz RMII clocks, group A
37	50MHz_0A	O, SE	50MHz RMII clocks, group A
38	SCLK	I	Serial Interface bus clock input.
39	SDATA	I/O	Serial Interface bus data input and output.
40	PWRGD/PWRDWN#	I	3.3V LVTTTL input. It acts as a level sensitive strobe.



Block Diagram

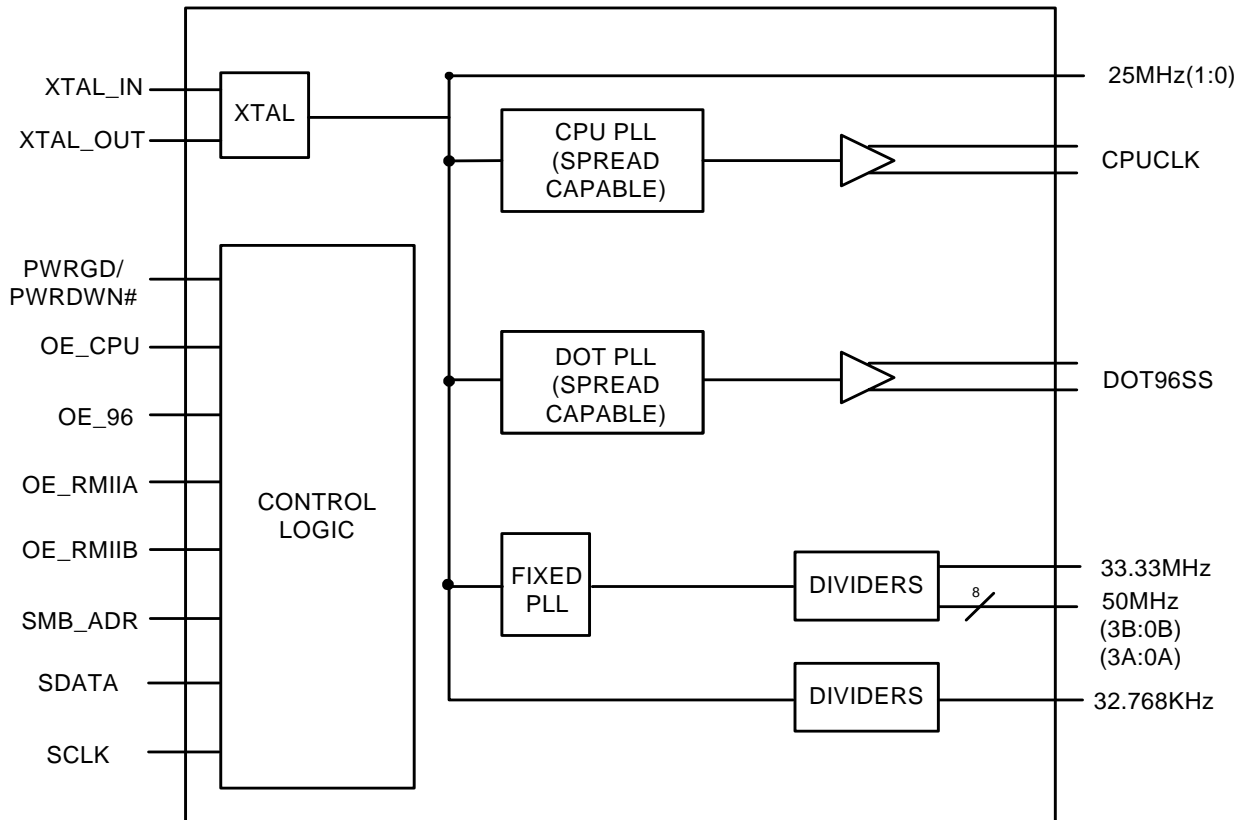

PD# (Power Down) Clarification

The PWRGD/PWRDWN# pin is a dual function pin. During initial power-up, the pin functions as PWRGD. Once PWRGD/PWRDWN# has been sampled low by the device, the pin assumes PWRDWN# functionality. The PWRDWN# pin is an asynchronous active low input used to shut off ALL clocks cleanly prior to shutting off power to the device. This signal is synchronized internal to the device prior to powering down the clock synthesizer. When PWRDWN# is asserted low, all clocks are driven to a low value and held prior to turning off the VCOs and the crystal oscillator.

Table 1. PD# Functionality

PD#	133	133#	DOT_96	DOT_96#	50MHz	33.3MHz	25MHz	32.769kHz
1	Normal	Normal	Normal	Normal	50MHz	33.3MHz	25MHz	32.769kHz
0	Iref*2 or Float	Float	Iref*2 or Float	Float	Low	Iref*2 or Float	Low	Low



PWRDWN# - Assertion

When PWRDWN# is sampled low by two consecutive rising edges of 133MHz, all single-ended outputs will be held low on their next high to low transition and differential clocks will be held high or tristated (depending on the state of the control register drive mode bit) on the next "Diff clock#" high to low transition.

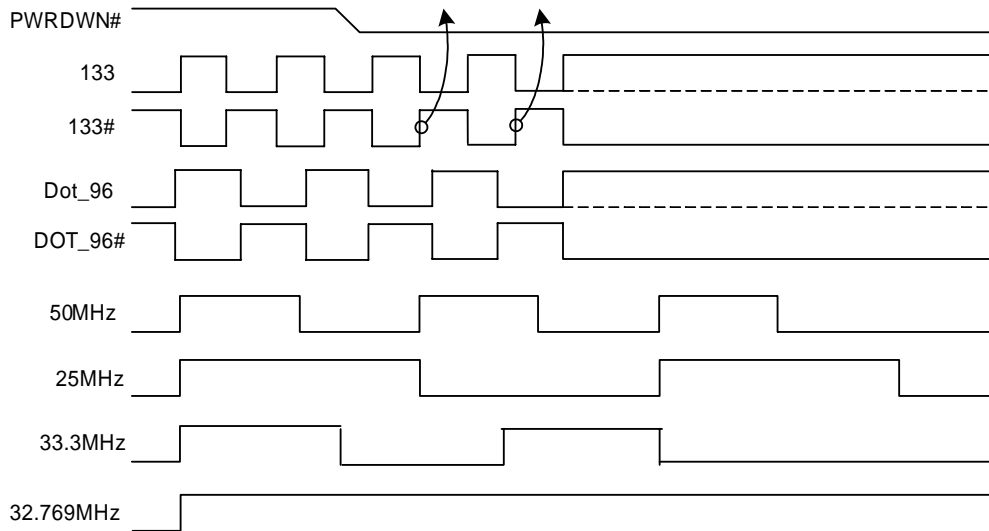

Figure 1. Power Down Assertion

PWRDWN# De-assertion

The power-up latency is less than 2.5ms. This is the time from the de-assertion of the PWRDWN# pin or the ramping of the power supply until the time that stable clocks are output from the clock device. All differential outputs stopped in a tristate condition resulting from power down will be driven high in less than 300us of PWRDWN# de-assertion to voltage greater than 200mV. After the clock chip's internal PLL is powered up and locked, all outputs are to be enabled within a few clock cycles of each other.

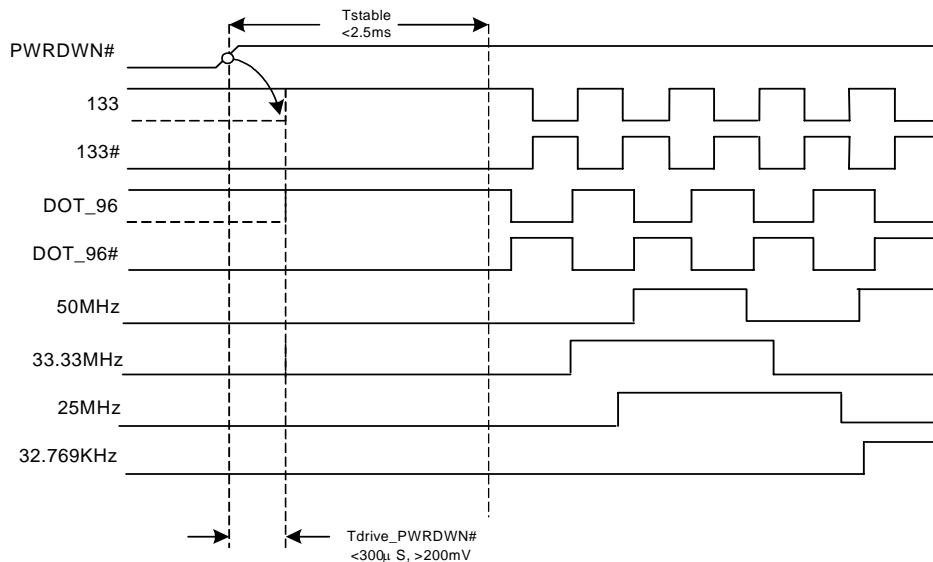

Figure 2. Power Down De-assertion



Serial Bus Interface

A two-wire serial interface is provided as the programming interface for the clock synthesizer. The serial interface is fully compliance to the SMBus 2.0 specification. The registers associated with the two-wire interface initializes to their default setting upon power-up, and therefore use of this interface is optional.

The serial interface supports block write and block read operation from any SMBus master devices. For block write and block read operations, the bytes must be accessed in sequential order from lowest to highest byte (most significant bit first) with the ability to stop after any complete byte has been transferred. The block write and block read protocol is outlined in Table 2. The slave receiver address is related to SMBADR.

Table 2. Block Read and Block Write protocol

Block Write Protocol		Block Read Protocol	
Bit	Description	Bit	Description
1	Start	1	Start
2:8	Slave address - 7 bits	2:8	Slave address - 7 bits
9	Write	9	Write
10	Acknowledge from slave	10	Acknowledge from slave
11:18	Command Code - 8 Bit'00000000' stands for block operation	11:18	Command Code - 8 Bit'00000000' stands for block operation
19	Acknowledge from slave	19	Acknowledge from slave
20:27	Byte Count - 8 bits	20	Repeat start
28	Acknowledge from slave	21:27	Slave address - 7 bits
29:36	Data byte 0 - 8 bits	28	Read
37	Acknowledge from slave	29	Acknowledge from slave
38:45	Data byte 1 - 8 bits	30:37	Byte count from slave - 8 bits
46	Acknowledge from slave	38	Acknowledge
....	Data Byte N/Slave Acknowledge...	39:46	Data byte from slave - 8 bits
....	Data Byte N - 8 bits	47	Acknowledge
....	Acknowledge from slave	48:55	Data byte from slave - 8 bits
....	Stop	56	Acknowledge
		Data bytes from slave/Acknowledge
		Data byte N from slave - 8 bits
		Not Acknowledge
		Stop



Control Register Summary

Control Register 0

Bit	Type	Description/Function	Power up condition
7	-	Reserved	X
6	-	Reserved	X
5	-	Reserved	X
4	RW	DOT_96 Spread Spectrum Enable 0 = Disabled 1 = Enabled	0
3	RW	Differential Clock Spread Spectrum Enable 0 = Disabled 1 = Enabled	0
2	RW	Frequency Select Bit FS2 0 = Disabled 1 = Enabled	0
1	RW	Frequency Select Bit FS1 0 = Disabled 1 = Enabled	0
0	RW	Frequency Select Bit FS0 0 = Disabled 1 = Enabled	1

Control Register 1

Bit	Type	Description/Function	Power up condition
7	RW	50MHz_3B Output Enable 0 = Disabled 1 = Enabled (Disabled = Low)	1
6	RW	50MHz_2B Output Enable 0 = Disabled 1 = Enabled (Disabled = Low)	1
5	RW	50MHz_1B Output Enable 0 = Disabled 1 = Enabled (Disabled = Low)	1
4	RW	50MHz_0B Output Enable 0 = Disabled 1 = Enabled (Disabled = Low)	1
3	RW	50MHz_3A Output Enable 0 = Disabled 1 = Enabled (Disabled = Low)	1
2	RW	50MHz_2A Output Enable 0 = Disabled 1 = Enabled (Disabled = Low)	1



Control Register 1 (continued)

Bit	Type	Description/Function	Power up condition
1	RW	50MHz_1A Output Enable 0 = Disabled 1 = Enabled (Disabled = Low)	1
0	RW	50MHz_0A Output Enable 0 = Disabled 1 = Enabled (Disabled = Low)	1

Control Register 2

Bit	Type	Description/Function	Power up condition
7	RW	133MHz Drive Mode 0 = Driven 1 = Hi-Z	0
6	RW	DOT_96 Drive Mode 0 = Driven 1 = Hi-Z	0
5	RW	33.33MHz Output Enable 0 = Disabled 1 = Enabled (Disabled = Low)	1
4	RW	25MHz_1 Output Enable 0 = Disabled 1 = Enabled (Disabled = Low)	1
3	RW	25MHz_0 Output Enable 0 = Disabled 1 = Enabled (Disabled = Low)	1
2	RW	32.769KHz Output Enable 0 = Disabled 1 = Enabled (Disabled = Low)	1
1	RW	133MHz Output Enable 0 = Disabled 1 = Enabled (Disabled = Low)	1
0	RW	DOT_96 Output Enable 0 = Disabled 1 = Enabled (Disabled = Low)	1

Control Register 3

Bit	Type	Description/Function	Power up condition
7	-	Reserved	X
6	-	Reserved	X
5	-	Reserved	X
4	-	Reserved	X



Control Register 3 (continued)

Bit	Type	Description/Function	Power up condition
3	RW	DOT_96 FS3	0
2	RW	DOT_96 FS2	0
1	RW	DOT_96 FS1	0
0	RW	DOT_96 FS0	0

Control Register 4

Bit	Type	Description/Function	Power up condition
7	RW	50MHz_3B Strength Control 0 = 1x Strength 1 = 2x Strength	0
6	RW	50MHz_2B Strength Control 0 = 1x Strength 1 = 2x Strength	0
5	RW	50MHz_1B Strength Control 0 = 1x Strength 1 = 2x Strength	0
4	RW	50MHz_0B Strength Control 0 = 1x Strength 1 = 2x Strength	0
3	RW	50MHz_3A Strength Control 0 = 1x Strength 1 = 2x Strength	0
2	RW	50MHz_2A Strength Control 0 = 1x Strength 1 = 2x Strength	0
1	RW	50MHz_1A Strength Control 0 = 1x Strength 1 = 2x Strength	0
0	RW	50MHz_0A Strength Control 0 = 1x Strength 1 = 2x Strength	0

Control Register 5

Bit	Type	Description/Function	Power up condition
7	-	Reserved	X
6	-	Reserved	X
5	RW	33.33MHz Strength Control 0 = 1x Strength 1 = 2x Strength	1
4	RW	25MHz_1Strength Control 0 = 1x Strength 1 = 2x Strength	1
3	RW	25MHz_0 Strength Control 0 = 1x Strength 1 = 2x Strength	1



Control Register 5 (continued)

Bit	Type	Description/Function	Power up condition
2	RW	32.769KHz Strength Control 0 = 1x Strength 1 = 2x Strength	1
1	-	Reserved	X
0	-	Reserved	X

Control Register 6

Bit	Type	Description/Function	Power up condition
7	R	Revision Code bit 3	0
6	R	Revision Code bit 2	0
5	R	Revision Code bit 1	0
4	R	Revision Code bit 0	0
3	R	Vendor ID bit 3	0
2	R	Vendor ID bit 2	1
1	R	Vendor ID bit 1	1
0	R	Vendor ID bit 0	0

Control Register 7

Bit	Type	Description/Function	Power up condition
7	R	Device ID 7	0
6	R	Device ID 6	0
5	R	Device ID 5	1
4	R	Device ID 4	0
3	R	Device ID 3	0
2	R	Device ID 2	0
1	R	Device ID 1	1
0	R	Device ID 0	0

Control Register 8

Bit	Type	Description/Function	Power up condition
7	RW	Byte Count bit 7	0
6	RW	Byte Count bit 6	0
5	RW	Byte Count bit 5	0
4	RW	Byte Count bit 4	0
3	RW	Byte Count bit 3	1
2	RW	Byte Count bit 2	0
1	RW	Byte Count bit 1	0
0	RW	Byte Count bit 0	1



Crystal Recommendations

The SLG84502 requires a **Parallel Resonance Crystal**. Substituting a series resonance crystal will cause the SLG84502 to operate at the wrong frequency and violate the ppm specification. For most applications there is a 300ppm frequency shift between series and parallel crystals due to incorrect loading.

Table 3. Crystal Recommendations.

Frequency (Fund)	Cut	Loading	Load Cap	Drive (max.)	Overtone	Cut Accuracy (max.)	Temp Stability (max.)	Aging (max.)
25.00000MHz	AT	Parallel	20pF	0.1mW	Fundamental	35ppm	15ppm	5ppm

Absolute Maximum Ratings

Storage Temperature:-65°C to + 150°C

Supply Voltage (VDDA):-0.5 to 4.6V

Supply Voltage (VDD):-0.5 to 4.6V

3.3V Input Voltage:-0.5 to 4.6V

Operating Temperature (Ambient):0°C to +70°C

ESD Protection (Min):2000V

Lead Frame Material (for Green package): Sn/Bi

Reflow Temperature (for Green package): 260°C (10sec)

DC Electrical Characteristics

Operating Conditions

Symbol	Description	Conditions	Min	Typ	Max	Unit
VDDA	3.3V Core Supply Voltage	3.3V±5%	3.135		3.465	V
VDD	3.3V I/O Supply Voltage	3.3V±5%	3.135		3.465	V
V _{ih}	3.3V Input High Voltage	VDD	2.0		VDD+0.3	V
V _{il}	3.3V Input Low Voltage		VSS-0.3		0.8	V
V _{oh}	3.3V Output High Voltage	I _{oh} = -1mA	2.4			V
V _{ol}	3.3V Output Low Voltage	I _{ol} = 1mA			0.4	V
I _{il}	Input Leakage Current	0 < V _{in} < VDD	-5		+5	uA
C _{in}	Input Pin Capacitance		2.5		6	pF
C _{xtal}	Xtal Pin Capacitance		3		5	pF
C _{out}	Output Pin Capacitance		2.5		6	pF
L _{pin}	Pin Inductance				7	nH
I _{dd_PD_DR}	Powerdown Current	VDD = 3.465V All static inputs = VDD or VSS All differential pairs driven			50	mA
I _{dd_ON_TRI}	Powerdown Current	VDD = 3.465V All static inputs = VDD or VSS All differential pairs tristated			12	mA
I _{dd_ACTIVE}	All output drivers	All outputs driven			150	mA

**Differential 0.7V Timing Characteristics****133MHz Timing Characteristics (SSC Disabled)**

Symbol	Description	Min.	Max.	Unit	Notes
L _{accuracy}	Long term accuracy	-	100	ppm	
T _{period}	Average Period	7.4993	7.5008	ns	
T _{abs}	Absolute Min/Max Host CLK period	7.4143	7.6235	ns	
T _{rise}	Rise Time	175	700	ps	
T _{fall}	Fall Time	175	700	ps	
T _{rise}	Rise Time variation	-	125	ps	
T _{fall}	Fall Time variation	-	125	ps	
Rise/Fall Matching	Rise/Fall Matching	-	20	%	
V _{High}	Voltage High	660	850	mV	
V _{Low}	Voltage Low	-150	-	mV	
V _{cross(abs)}	Absolute Crossing Point Voltages	250	550	mV	
V _{cross(rel)}	Relative Crossing Point Voltages	Calc	Calc	-	
Total V _{cross}	Total Variation of Vcross Over All Edges	-	140	mV	
Edge_rate	Edge Rate	0.5	2.0	V/ns	
T _{jycyc-cyc}	Cycle to Cycle Jitter	-	85	ps	
Duty Cycle	Duty Cycle	35	65	%	
V _{ovs}	Maximum Voltage (Overshoot)	-	VH+0.3V	V	
V _{uds}	Maximum Voltage (Undershoot)	-0.3	-	V	
V _{rb}	Ringback Voltage	N/A	0.2	V	

**Differential 0.7V Timing Characteristics****133MHz Timing Characteristics (SSC Enabled)**

Symbol	Description	Min.	Max.	Unit	Notes
L _{accuracy}	Long term accuracy	-	100	ppm	
T _{period}	CLK period	7.4993	7.5385	ns	
T _{abs}	Absolute Min/Max Host CLK period	7.4143	7.6235	ns	
T _{rise}	Rise Time	175	700	ps	
T _{fall}	Fall Time	175	700	ps	
T _{rise}	Rise Time variation	-	125	ps	
T _{fall}	Fall Time variation	-	125	ps	
Rise/Fall Matching	Rise/Fall Matching	-	20	%	
V _{High}	Voltage High	660	850	mV	
V _{Low}	Voltage Low	-150	-	mV	
V _{cross(abs)}	Absolute Crossing Point Voltages	250	550	mV	
V _{cross(rel)}	Relative Crossing Point Voltages	Calc	Calc	-	
Total V _{cross}	Total Variation of Vcross Over All Edges	-	140	mV	
Edge_rate	Edge Rate	0.5	2.0	V/ns	
T _{jycyc-cyc}	Cycle to Cycle Jitter	-	85	ps	
Duty Cycle	Duty Cycle	45	55	%	
V _{ovs}	Maximum Voltage (Overshoot)	-	VH+0.3V	V	
V _{uds}	Maximum Voltage (Undershoot)	-0.3	-	V	
V _{rb}	Ringback Voltage	N/A	0.2	V	

DOT Timing Characteristics (SSC Disabled)

Symbol	Description	Min.	Max.	Unit	Notes
L _{accuracy}	Long term accuracy	-	300	ppm	
T _{period}	CLK period	10.4135	10.4196	ns	
T _{abs}	Absolute Min/Max Host CLK period	10.1635	10.7222	ns	
T _{rise}	Rise Time	175	700	ps	
T _{fall}	Fall Time	175	700	ps	
T _{rise}	Rise Time variation	-	125	ps	
T _{fall}	Fall Time variation	-	125	ps	
Rise/Fall Matching	Rise/Fall Matching	-	20	%	
V _{High}	Voltage High	660	850	mV	
V _{Low}	Voltage Low	-150	-	mV	
V _{cross(abs)}	Absolute Crossing Point Voltages	250	550	mV	
V _{cross(rel)}	Relative Crossing Point Voltages	Calc	Calc	-	
Total V _{cross}	Total Variation of Vcross Over All Edges	-	140	mV	
Edge_rate	Edge Rate	0.5	2.0	V/ns	
T _{jycyc-cyc}	Cycle to Cycle Jitter	-	250	ps	



DOT Timing Characteristics (SSC Disabled)

Symbol	Description	Min.	Max.	Unit	Notes
Duty Cycle	Duty Cycle	45	55	%	
V _{ovs}	Maximum Voltage (Overshoot)	-	VH+0.3V	V	
V _{uds}	Maximum Voltage (Undershoot)	-0.3	-	V	
V _{rb}	Ringback Voltage	N/A	0.2	V	

**AC Electrical Characteristics****RMII 50MHz Timing Characteristics**

Symbol	Description	Min.	Max.	Unit	Notes
L _{accuracy}	Long term accuracy	-	50	ppm	2, 4
T _{period}	CLK period	19.99900	20.00100	ns	2, 3
T _{rise}	Rise Time	1.0	3.0	ns	
T _{fall}	Fall Time	1.0	3.0	ns	
T _{jycyc-cyc}	Cycle to Cycle Jitter	-	250	ps	2
Duty Cycle	Duty Cycle	35	65	%	

33.33MHz Timing Characteristics

Symbol	Description	Min	Max	Units	Conditions
L _{accuracy}	Long term accuracy	-	300	ppm	2, 4
T _{period}	CLK period	29.99100	30.00900	ns	2,3
T _{rise}	Rise Time	0.5	2.0	ns	
T _{fall}	Fall Time	0.5	2.0	ns	
T _{jycyc-cyc}	Cycle to cycle jitter	-	350	ps	2
Duty Cycle	Duty Cycle	45	55	%	

25MHz Timing Characteristics

Symbol	Description	Min	Max	Units	Conditions
L _{accuracy}	Long term accuracy	-	50	ppm	2, 4
T _{rise}	CLK period	39.99800	40.00200	ns	2, 3
T _{fall}	CLK high time	0.5	2.0	ns	
T _{low}	CLK low time	0.5	2.0	ns	
T _{jycyc-cyc}	Cycle to cycle jitter	-	500	ps	2
Duty Cycle	Duty Cycle	45	55	%	



32.769 Timing Characteristics

Symbol	Description	Min	Max	Units	Conditions
L_{accuracy}	Long term accuracy	-	300	ppm	2, 4
T_{period}	CLK period	30.50685	30.52515	us	2,3
T_{rise}	CLK high time	0.5	2.0	ns	
T_{fall}	CLK low time	0.5	2.0	ns	
$T_{\text{jyc-cyc}}$	Cycle to cycle jitter	-	500	ps	2
Duty Cycle	Duty Cycle	45	55	%	

¹ Edge rate measured from 0.8V to 2.0V

² Duty cycle, Period and Jitter are measured with respect to 1.5V

³ The average period over any 1us period of time

⁴ Using frequency counter with the measurement interval equal or greater than 0.15s, the target frequencies are 50,000,000Hz, 33,333,333 Hz, 25,000,000Hz, 32,769,000Hz

Ordering Information

Part Number	Package Type	Temperature Range
SLG84502V	40-LEAD QFN	Commercial, 0° to 70°C



Package Drawing and Dimensions - 40 Lead QFN Package

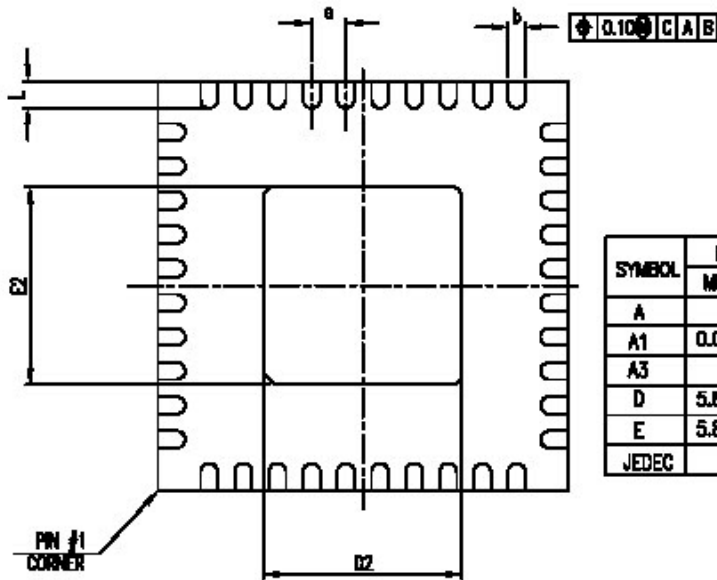
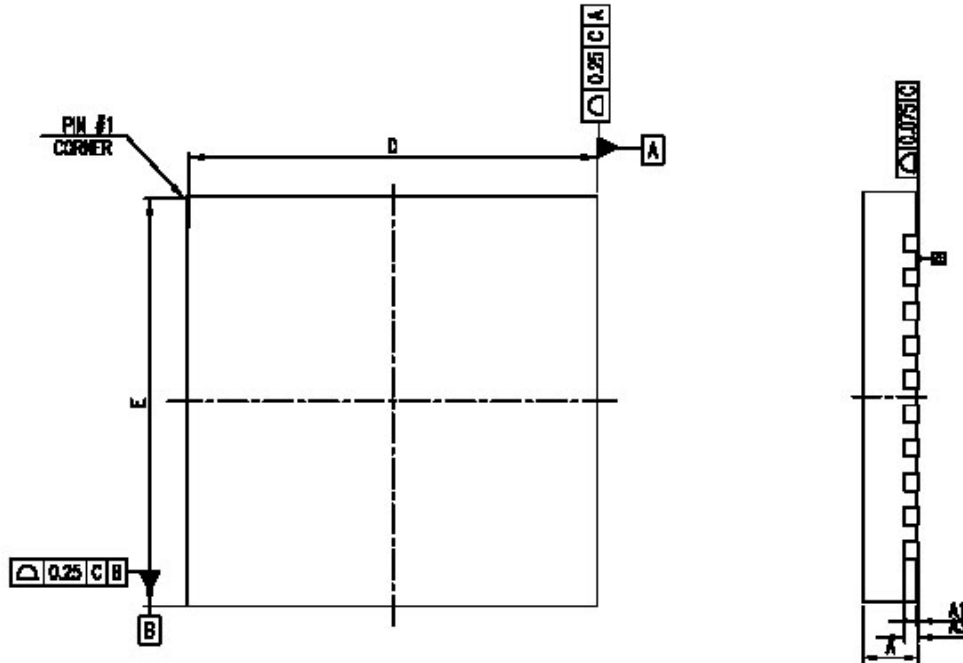

SYMBOL	DIMENSION IN MM			DIMENSION IN INCH		
	MIN.	NOM.	MAX.	MIN.	NOM.	MAX.
A		0.80	0.84		0.031	0.033
A1	0.00	0.02	0.04	0.00	0.0008	0.0015
A3	0.20 REF.			0.008 REF.		
D	5.85	6.00	6.15	0.230	0.236	0.242
E	5.85	6.00	6.15	0.230	0.236	0.242
JEDEC	MO-220					

N	b			D2			E2			p	L			JEDEC
	MIN.	NOM.	MAX.	MIN.	NOM.	MAX.	MIN.	NOM.	MAX.		MIN.	NOM.	MAX.	
40L	0.20	0.25	0.30	2.85	2.90	2.95	2.85	2.90	2.95	0.500 BSC	0.35	0.40	0.45	MO-220AJD-S