

2691 Universal Asynchronous Receiver/Transmitter (UART)

Objective Specification

Military Communications and Industrial Products

DESCRIPTION

The Signetics 2691 Universal Asynchronous Receiver/Transmitter (UART) is a single-chip CMOS-LSI communications device that provides a full-duplex asynchronous receiver/transmitter in a single 24-pin Skinny DIP. It is fabricated with Signetics CMOS technology which combines the benefits of high density and low power consumption.

The operating speed of the receiver and transmitter can be selected independently as one of 18 fixed baud rates, a 16X clock derived from a programmable counter/timer, or an external 1X or 16X clock. The baud rate generator and counter/timer can operate directly from a crystal or from external clock inputs. The ability to independently program the operating speed of the receiver and transmitter make the UART particularly attractive for dual-speed channel applications such as clustered terminal systems.

The receiver is quadruple buffered to minimize the potential of receiver overrun or to reduce interrupt overhead in interrupt driven systems. In addition, a handshaking capability is provided to disable a remote UART transmitter when the receiver buffer is full.

The UART provides a power-down mode in which the oscillator is frozen but the register contents are stored. This results in reduced power consumption on the order of several magnitudes.

The UART is fully TTL compatible and operates from a single +5V power supply.

ORDERING INFORMATION

DESCRIPTION	ORDER CODE
24-Pin Ceramic DIP	2691/BLA
28-Pin LLCC	2691/B3A

FEATURES

- Full-duplex asynchronous receiver/transmitter
- Quadruple buffered receiver data register
- Programmable data format:
 - 5 to 8 data bits plus parity
 - Odd, even, no parity or force parity
 - 1, 1.5 or 2 stop bits programmable in 1/16-bit increments
- Baud rate for the receiver and transmitter selectable from:
 - 18 fixed rates: 50 to 38.4K baud
 - One user-defined rate derived from programmable timer/counter
 - External 1X or 16X clock
- Parity, framing, and overrun detection
- False start bit detection
- Line break detection and generation
- Programmable channel mode
 - Normal (full-duplex)
 - Automatic echo
 - Local loopback
 - Remote Loopback
- Multi-function programmable 16-bit counter/timer
- Single interrupt output with seven maskable interrupting conditions
- On-chip crystal oscillator
- Low power mode
- TTL compatible
- Single +5V power supply

PIN CONFIGURATIONS

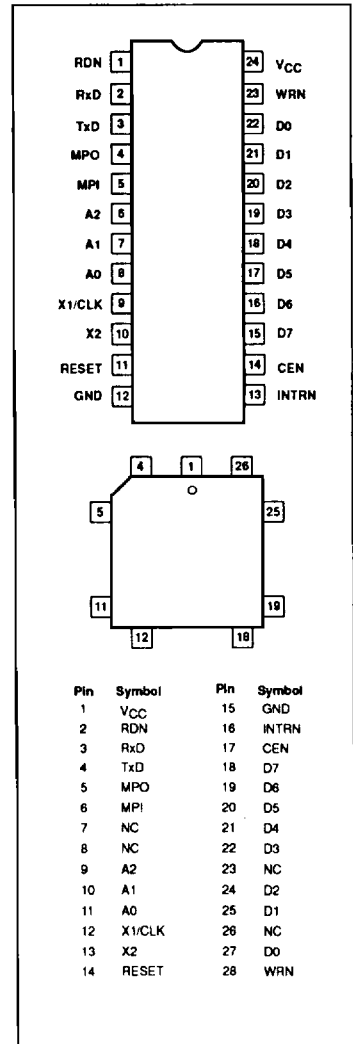

Universal Asynchronous Receiver/Transmitter (UART)

2691

BLOCK DIAGRAM

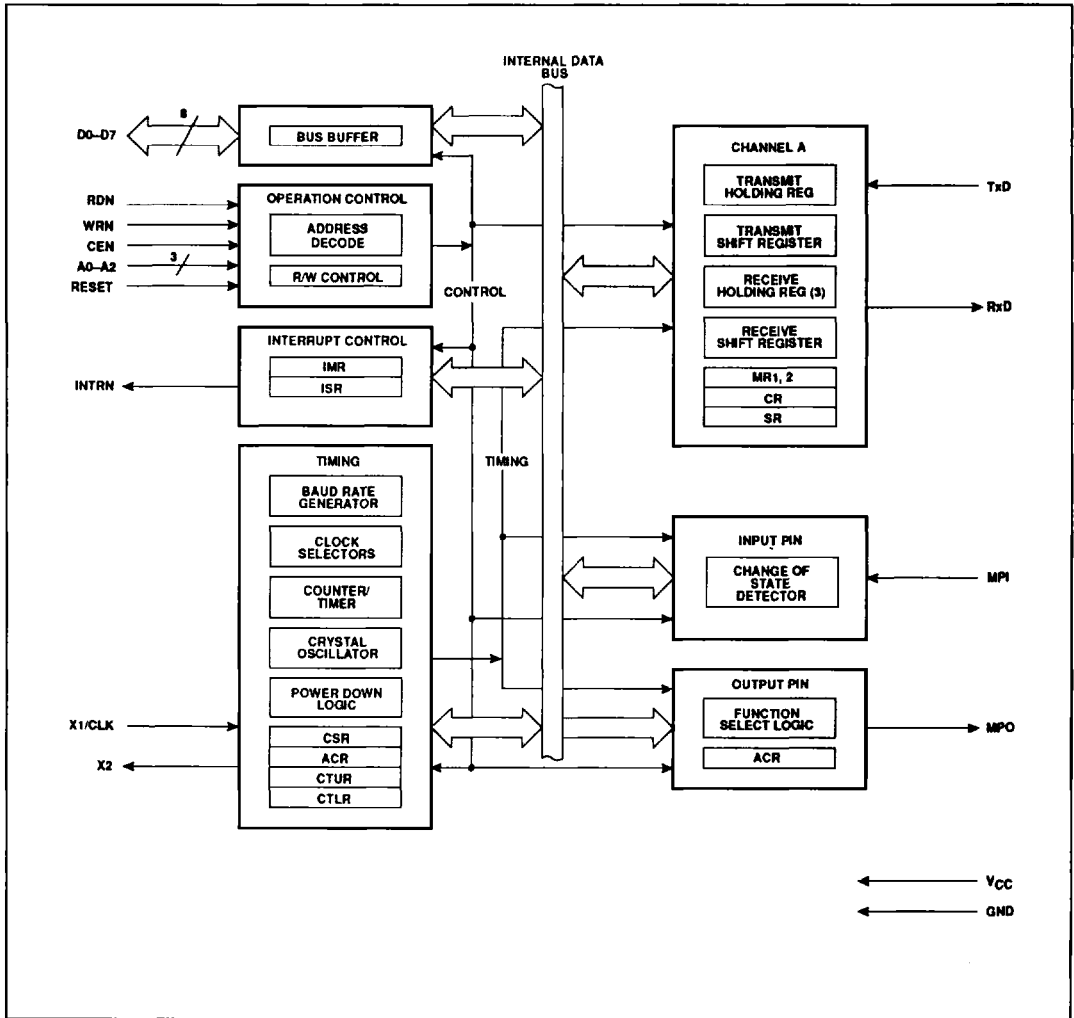

Universal Asynchronous Receiver/Transmitter (UART)

2691

PIN DESCRIPTION

MNEMONIC	PIN NO.		TYPE	NAME AND FUNCTION
	DIP	LLCC		
D0–D7	22–15	27, 25, 24, 22–18	I/O	Data Bus: Active-high 8-bit bidirectional 3-state data bus. Bit 0 is the LSB and bit 7 is the MSB. All data, command, and status transfers between the CPU and the UART take place over this bus. The direction of the transfer is controlled by the WRN and RDN inputs when the CEN input is low. When the CEN input is high, the data bus is in the 3-state condition.
CEN	14	17	I	Chip Enable: Active-low input. When low, data transfers between the CPU and the UART are enabled on D0–D7 as controlled by the WRN, RDN and A0–A2 inputs. When CEN is high, the UART is effectively isolated from the data bus and D0–D7 are placed in the 3-state condition.
WRN	28	28	I	Write Strobe: Active-low input. A low on this pin while CEN is low causes the contents of the data bus to be transferred to the register selected by A0–A2. The transfer occurs on the trailing (rising) edge of the signal.
RDN	1	2	I	Read Strobe: Active-low input. A low on this pin while CEN is low causes the contents of the register selected by A0–A2 to be placed on the data bus. The read cycle begins on the leading (falling) edge of RDN.
A0–A2	8–6	11–9	I	Address Inputs: Active-high address inputs to select the UART registers for read/write operations.
RESET	11	14	I	Reset: Master reset. A high on this pin clears the status register (SR), the interrupt mask register (IMR), and the interrupt status register (ISR), sets the mode register pointer to MR1, and places the receiver and transmitter in the inactive state causing the TxD output to go to the marking (high) state.
INTRN	13	16	O	Interrupt Request: This active-low output is asserted upon occurrence of one or more of seven maskable interrupting conditions. The CPU can read the interrupt status register to determine the interrupting condition(s). This open-drain output requires a pull-up resistor.
X1/CLK	9	12	I	Crystal 1: Crystal or external clock input. When using the crystal oscillator, this pin serves as the connection for one side of the crystal. If a crystal is not used, an external clock is supplied at this input. An external clock (or crystal) is required even if the internal baud rate generator is not utilized. This clock is used to drive the internal baud rate generator, as an optional input to the timer/counter, and to provide other clocking signals required by the chip.
X2	10	13	I	Crystal 2: Connection for other side of crystal. If an external source is used instead of a crystal, this connection should be open. (See Figure 5)
RxD	2	3	I	Receiver Serial Data Input: The least significant bit is received first. If external receiver clock is specified, this input is sampled on the rising edge of the clock.
TxD	3	4	O	Transmitter Serial Data Output: The least significant bit is transmitted first. This output is held in the marking (high) condition when the transmitter is idle or disabled and when the UART is operating in local loopback mode. If external transmitter is specified, the data is shifted on the falling edge of the transmitter clock.
MPO	4	5	O	Multi-Purpose Output: One of the following functions can be selected for this output pin by programming the auxiliary control register: RTSN – Request to send active-low output. This output is asserted and negated via the command register. By appropriate programming of the mode registers, RTSN can be programmed to be automatically reset after the character in the transmitter is completely shifted or when the receiver FIFO and shift register are full. C/TO – The counter/timer output. TxC1X – The 1X clock for the transmitter. TxC16X – The 16X clock for the transmitter. RxC1X – The 1X clock for the receiver. RxC16X – The 16X clock for the receiver. TxRDY – The transmitter holding register empty signal. Active-low output. RxRDY/FFULL – The receiver FIFO not empty/full signal. Active-low output.
MPI	5	6	I	Multi-Purpose Input: This pin can serve as an input for one of the following functions: GPI – General purpose input. The current state of the pin can be determined by reading the ISR. CTSN – Clear-to-send active-low input. CTCLK – Counter/timer external clock input. RTCLK – Receiver and/or transmitter external clock input. This may be a 1X or 16X clock as programmed by CSR[3:0] or CSR[7:4].
V _{CC}	24	1	I	Power Supply: +5V supply input.
GND	12	15	I	Ground

Universal Asynchronous Receiver/Transmitter (UART)

2691

BLOCK DIAGRAM

As shown in the block diagram, the UART consists of: data bus buffer, interrupt control, operation control, timing, receiver and transmitter.

Data Bus Buffer

The data bus buffer provides the interface between the external and internal data buses. It is controlled by the operation control block to allow read and write operations to take place between the controlling CPU and UART.

Interrupt Control

A single interrupt output (INTRN) is provided which may be asserted upon occurrence of any of the following internal events:

- Transmit holding register ready
- Transmit shift register empty
- Receive holding register ready or FIFO full
- Change in break received status
- Counter reached terminal count
- Change in MPI input
- Assertion of MPI input

Associated with the interrupt system are the interrupt mask register (IMR) and the interrupt status register (ISR). The IMR can be programmed to select only certain of the above conditions to cause INTRN to be asserted. The ISR can be read by the CPU to determine all currently active interrupting conditions. However, the bits of the ISR are not masked by the IMR.

Operation Control

The operation control logic receives operation commands from the CPU and generates appropriate signals to internal sections to control device operation. It contains address decoding and read and write circuits to permit communications with the microprocessor via the data bus buffer. The functions performed by the CPU read and write operations are shown in Table 1.

Mode registers 1 and 2 are accessed via an auxiliary pointer. The pointer is set to MR1 by RESET or by issuing a reset pointer command via the command register. Any read or write of the mode register while the pointer is at MR1 switches the pointer to MR2. The pointer then remains at MR2 so that subsequent accesses are to MR2, unless the pointer is reset to MR1 as described above.

Table 1. Register Addressing

A2	A1	A0	READ (RDN = 0)	WRITE (WRN = 0)
0	0	0	MR1, MR2	MR1, MR2
0	0	1	SR	CSR
0	1	0	Reserved*	CR
0	1	1	RHR	THR
1	0	0	Reserved*	ACR
1	0	1	ISR	IMR
1	1	0	CTU	CTUR
1	1	1	CTL	CTLR

NOTE;
 *Reserved registers should never be read during operation since they are reserved for internal diagnostics.
 ACR = Auxiliary control register
 CR = Command register
 CSR = Clock select register
 CTL = Counter/timer lower
 CTLR = Counter/timer lower register
 CTU = Counter/timer upper
 CTUR = Counter/timer upper register
 MR = Mode register A
 SR = Status register
 THR = Tx holding register

Timing Circuits

The timing block consists of a crystal oscillator, a baud rate generator, a programmable 16-bit counter/timer, and two clock selectors.

The crystal oscillator operates directly from a 3.6864MHz crystal connected across the X1/CLK and X2 inputs with a minimum of external components. If an external clock of the appropriate frequency is available, it may be connected to X1/CLK. If an external clock is used instead of a crystal, X1/CLK is driven using a configuration similar to the one in Figure 5. In this case, the input high-voltage must be capable of attaining the voltage specified in the DC Electrical Characteristics. The clock serves as the basic timing reference for the baud rate generator (BRG), the counter/timer, and other internal circuits. A clock frequency, within the limits specified in the electrical specifications, must be supplied if the internal BRG is not used.

The baud rate generator operates from the oscillator or external clock input and is capable of generating 18 commonly used data communications baud rates ranging from 50 to 38.4K baud. Thirteen of these are available simultaneously for use by the receiver and transmitter. Eight are fixed, and one of two sets of five can

be selected by programming ACR[7]. The clock outputs from the BRG are at 16X the actual baud rate. The counter/timer can be used as a timer to produce a 16X clock for any other baud rate by counting down the crystal clock or an external clock. The clock selectors allow the independent selection by the receiver and transmitter of any of these baud rates or an external timing signal.

The C/T operation is programmed by ACR[6:4]. One of eight timing sources can be used as the input to the C/T. The output of the C/T is available to the clock selectors and can be programmed by ACR[2:0] to be output on the MPO pin.

In the timer mode, the C/T generates a square wave whose period is twice the number of clock periods loaded into the C/T upper and lower registers. The counter ready bit in the ISR is set once each cycle of the square wave. If the value in CTUR or CTLR is changed, the current half-period will not be affected, but subsequent half-periods will be affected. In this mode the C/T runs continuously and does not recognize the stop counter command (the command only resets the counter ready bit in the ISR). Receipt of a start C/T command causes the counter to terminate the current timing cycle and to begin a new cycle using the values in CTUR and CTLR.

In the counter mode, the C/T counts down the number of pulses loaded into CTUR and CTLR. Counting begins upon receipt of a start C/T command. Upon reaching terminal count, the counter ready bit in the ISR is set. The counter continues counting past the terminal count until stopped by the CPU. If MPO is programmed to be the output of the C/T, the output remains high until terminal count is reached, at which time it goes low. The output returns to the high state and the counter ready bit is cleared when the counter is stopped by a stop counter command. The CPU may change the values of CTUR and CTLR at any time, but the new count becomes effective only on the next start counter command following a stop counter command. If new values have not been loaded, the previous count values are preserved and used for the next count cycle.

In the counter mode, the current value of the upper and lower eight bits of the counter may be read by the CPU. It is recommended that the

Universal Asynchronous Receiver/Transmitter (UART)

2691

counter be stopped when reading to prevent potential problems which may occur if a carry from the lower eight bits to the upper eight bits occurs between the times that both halves of the counter are read. However, a subsequent start counter command causes the counter to begin a new count cycle using the values in CTUR and CTLR.

Receiver and Transmitter

The UART is a full-duplex asynchronous receiver/transmitter. The operating frequency for the receiver and transmitter can be selected independently from the baud rate generator, the counter/timer, or from an external input. Registers associated with the communications channel are: the mode registers (MR1 and MR2), the clock select register (CSR), the command register (CR), the status register (SR), the transmit holding register (THR), and the receive holding register (RHR).

Transmitter

The transmitter accepts parallel data from the CPU and converts it to a serial bit stream on the TxD output pin. It automatically sends a start bit followed by the programmed number of data bits, an optional parity bit, and the programmed number of stop bits. The least significant bit is sent first. Following the transmission of the stop bits, if a new character is not available in the THR, the TxD output remains high and the TxEMT bit in the SR will be set to 1. Transmission resumes and the TxEMT bit is cleared when the CPU loads a new character in the THR. In the 16X clock mode, this also resynchronizes the internal 1X transmitter clock so that transmission of the new character begins with minimum delay.

The transmitter can be forced to send a break (continuous low condition) by issuing a start break command via the CR. The break is terminated by a stop break command.

If the transmitter is disabled, it continues operating until the character currently being transmitted and the character in the THR, if any, are completely sent out. Characters cannot be loaded in the THR while the transmitter is disabled.

Receiver

The receiver accepts serial data on the RxD pin, converts the serial input to parallel format, checks for start bit, stop bit, parity bit (if any), or break condition, and presents the assembled character to the CPU. The receiver looks for a high-to-low (mark-to-space) transition of the start bit on the RxD input pin. If a transition is detected, the state of the RxD pin is sampled again each 16X clock for 7-1/2 clocks (16X clock mode) or at the next rising edge of the bit time clock (1X clock mode). If RxD is sampled high, the start bit is invalid and the search for a

valid start bit begins again. If RxD is still low, a valid start bit is assumed and the receiver continues to sample the input at one bit time intervals at the theoretical center of the bit, until the proper number of data bits and the parity bit (if any) have been assembled, and one stop bit has been detected. The data is then transferred to the RHR and the RxRDY bit in the SR is set to a 1. If the character length is less than eight bits, the most significant unused bits in the RHR are set to zero.

After the stop bit is detected, the receiver will immediately look for the next start bit. However, if a non-zero character was received without a stop bit (i.e. framing error) and RxD remains low for one-half of the bit period after the stop bit was sampled, then the receiver operates as if a new start bit transition had been detected at that point (one-half bit time after the stop bit was sampled). The parity error, framing error and overrun error (if any) are strobed into the SR at the received character boundary, before the RxRDY status bit is set.

If a break condition is detected (RxD is low for the entire character including the stop bit), only one character consisting of all zeros will be loaded in the FIFO and the received break bit in the SR is set to 1. The RxD input must return to a high condition for two successive clock edges of the 1X clock (internal or external) before a search for the next start bit begins.

RECEIVER FIFO

The RHR consists of a first-in-first-out (FIFO) queue with a capacity of three characters. Data is loaded from the receive shift register into the top-most empty position of the FIFO. The RxRDY bit in the status register (SR) is set whenever one or more characters are available to be read, and a FFULL status bit is set if all three queue positions are filled with data. Either of these bits can be selected to cause an interrupt. A read of the RHR outputs the data at the top of the FIFO. After the read cycle, the data FIFO and its associated status bits are 'popped' thus emptying a FIFO position for new data.

In addition to the data word, three status bits (parity error, framing error, and received break) are appended to each data character in the FIFO. Status can be provided in two ways, as programmed by the error mode control bit in mode register 1. In the character mode, status is provided on a character-by-character basis: the status applies only to the character at the top of the FIFO. In the block mode, the status provided in the SR for these three bits is the logical-OR of the status for all characters coming to the top of the FIFO since the last reset error command was issued. In either mode, reading the SR does not affect the FIFO. The FIFO is 'popped' only when the RHR is read. Therefore,

the SR should be read prior to reading the corresponding data character.

If the FIFO is full when a new character is received, that character is held in the receive shift register until a FIFO position is available. If an additional character is received while this state exists, the contents of the FIFO are not affected: the character previously in the shift register is lost and the overrun error status bit (SR[4]) will be set upon receipt of the start bit of the new (overrunning) character.

WAKE-UP MODE

In addition to the normal transmitter and receiver operation described above, the UART incorporates a special mode which provides automatic wake-up of the receiver through address frame recognition for multi-processor communications. This mode is selected by programming bits MR1[4:3] to '11'.

In this mode of operation, a 'master' station transmits an address character followed by data characters for the addressed 'slave' station. The slave stations, whose receivers are normally disabled, examine the received data stream and 'wake-up' the CPU [by setting RxRDY] only upon receipt of an address character. The CPU compares the received address to its station address and enables the receiver if it wishes to receive the subsequent data characters. Upon receipt of another address character, the CPU may disable the receiver to initiate the process again.

A transmitted character consists of a start bit, the programmed number of data bits, an address/data (A/D) bit, and the programmed number of stop bits. The polarity of the transmitted A/D bit is selected by the CPU by programming bit MR1[2]. MR1[2] = 0 transmits a zero in the A/D bit position which identifies the corresponding data bits as data, while MR1[2] = 1 transmits a one in the A/D bit position which identifies the corresponding data bits as an address. The CPU should program the mode register prior to loading the corresponding data bits in the THR.

While in this mode, the receiver continuously looks at the received data stream, whether it is enabled or disabled. If disabled, it sets the RxRDY status bit and loads the character in the RHR FIFO if the received A/D bit is a one, but discards the received character if the received A/D bit is a zero. If enabled, all received characters are then transferred to the CPU via the RHR. In either case, the data bits are loaded in the data FIFO while the A/D bit is loaded in the status FIFO position normally used for parity error (SR[5]). Framing error, overrun error, and break detect operate normally whether or not the receiver is enabled.

Universal Asynchronous Receiver/Transmitter (UART)

2691

MULTI-PURPOSE INPUT PIN

The MPI pin can be programmed as an input to one of several UART circuits. The function of the pin is selected by programming the appropriate control register (MR2[4]), ACR[6:4], CSR [7:4, 3:0]. Only one of the functions may be selected at any given time. If CTS or GPI is selected, a change of state detector provided with the pin is activated. A high-to-low or low-to-high transition of the inputs lasting longer than 25–50 μ s sets the MPI change-of-state bit in the interrupt status register. The bit is cleared via a command. The change-of-state can be programmed to generate an interrupt to the CPU by setting the corresponding bit in the interrupt mask register.

The input port pulse detection circuitry uses a 38.4kHz sampling clock derived from one of the baud rate generator taps. This produces a sampling period of slightly more than 25 μ s (assuming a 3.6864MHz oscillator input). The detection circuitry, in order to guarantee that a true change in level has occurred, requires two successive samples at the new logic level be observed. As a consequence, the minimum duration of the signal change is 25 μ s if the transition occurs coincident with the first sample pulse. The 50 μ s time refers to the condition where the change of state is just missed and the first change of state is not detected until after an additional 25 μ s.

MULTI-PURPOSE OUTPUT PIN

This pin can be programmed to serve as a request-to-send output, the counter/timer output, the output for the 1X or 16X transmitter or receiver clocks, the TxRDY output or the RxRDY/FFULL output (see ACR[2:0] – MPO Output Select).

REGISTERS

The operation of the UART is programmed by writing control words in the appropriate registers. Operational feedback is provided via status registers which can be read by the CPU. Addressing of the registers is as described in Table 1.

The contents of certain control registers are initialized to zero on reset (see RESET pin description). Care should be exercised if the contents of a register are changed during operation, since certain changes may cause operational problems. For example, changing the number of bits per character while the transmitter is active may cause the transmission of an incorrect character. The contents of the MR, the CSR, and the ACR should only be changed while the receiver and transmitter are disabled, and certain changes to the ACR should only be made while the C/T is stopped. The bit formats of the UART are shown in Table 2.

MR1 – Mode Register 1

MR1 is accessed when the MR pointer points to MR1. The pointer is set to MR1 by RESET or by a set pointer command applied via the CR. After reading or writing MR1, the pointers are set at MR2.

MR1[7] – Receiver Request-to-Send Control

The bit controls the deactivation of the RTSN output (MPO) by the receiver. This output is normally asserted and negated by commands applied via the command register. MR1[7] = 1 causes RTSN to be automatically negated upon receipt of a valid start bit if the receiver FIFO is full. RTSN is reasserted when an empty FIFO position is available. This feature can be used to prevent overrun in the receiver by using the RTSN output signal to control the CTS input of the transmitting device.

MR1[6] – Receiver Interrupt Select

This bit selects either the receiver ready status (RxRDY) or the FIFO full status (FFULL) to be used for CPU interrupts.

MR1[5] – Error Mode Select

This bit selects the operating mode of the three FIFOed status bits (FE, PE, received break). In the character mode, status is provided on a character-by-character basis. The status applies only to the character at the top of the FIFO. In the block mode, the status provided in the SR for these bits is the accumulation (logical-OR) of the status for all characters coming to the top of the FIFO since the last reset error command was issued.

MR1[4:3] – Parity Mode Select

If with parity or force parity is selected, a parity bit is added to the transmitted character and the receiver performs a parity check on incoming data. MR1[4:3] = 11 selects the channel to operate in the special wake-up mode.

MR1[2] – Parity Type Select

This bit selects the parity type (odd or even) if the with parity mode is programmed by MR1[4:3], and the polarity of the forced parity bit if the force parity mode is programmed. It has no effect if the no parity mode is programmed. In the special wake-up mode, it selects the polarity of the transmitted A/D bit.

MR1[1:0] – Bits Per Character Select

This field selects the number of data bits per character to be transmitted and received. The character length does not include the start, parity, and stop bits.

MR2 – Mode Register 2

MR2 is accessed when the channel MR pointer points to MR2, which occurs after any access

to MR1. Accesses to MR2 do not change the pointer.

MR2[7:6] – Mode Select

The UART can operate in one of four modes. MR2[7:6] = 00 is the normal mode, with the transmitter and receiver operating independently. MR2[7:6] = 01 places the channel in the automatic echo mode, which automatically retransmits the received data. The following conditions are true while in automatic echo mode:

- Received data is relocked and retransmitted on the TxD output.
- The receive clock is used for the transmitter.
- The receiver must be enabled, but the transmitter need not be enabled.
- The TxRDY and TxEMT status bits are inactive.
- The received parity is checked, but is not regenerated for transmission, i.e., transmitted parity bit is as received.
- Character framing is checked, but the stop bits are retransmitted as received.
- A received break is echoed as received until the next valid start bit is detected.
- CPU-to-receiver communication continues normally, but the CPU-to-transmitter link is disabled.

Two diagnostic modes can also be selected. MR2[7:6] = 10 selects local loopback mode. In this mode:

- The transmitter output is internally connected to the receiver input.
- The transmit clock is used for the receiver.
- The TxD output is held high.
- The RxD input is ignored.
- The transmitter must be enabled, but the receiver need not be enabled.
- CPU to transmitter and receiver communications continue normally.

The second diagnostic mode is the remote loopback mode, selected by MR2[7:6] = 11. In this mode:

- Received data is relocked and retransmitted on the TxD output.
- The receive clock is used for the transmitter.
- Received data is not sent to the local CPU, and the error status conditions are inactive.
- The received parity is not checked and is not regenerated for transmission, i.e., the transmitted parity bit is as received.
- The receiver must be enabled, but the transmitter need not be enabled.
- Character framing is not checked, and the stop bits are retransmitted as received.
- A received break is echoed as received until the next valid start bit is detected.

When switching in and out of the various modes, the selected mode is activated immediately upon mode selection, even if this occurs

Universal Asynchronous Receiver/Transmitter (UART)

2691

in the middle of a received or transmitted character. Likewise, if a mode is deselected, the device will switch out of the mode immediately. An exception to this is switching out of auto-echo or remote loopback modes; if the deselection occurs just after the receiver has sampled the stop bit (indicated in auto-echo by assertion of RxDY), and the transmitter is enabled, the transmitter will remain in auto-echo mode until one full stop bit has been retransmitted.

MR2[5] – Transmitter Request-to-Send Control

This bit controls the deactivation of the RTSN output (MPO) by the transmitter. This output is normally asserted and negated by appropriate commands issued via the command register. MR2[5] = 1 causes RTSN to be reset automatically one bit time after the characters in the transmit shift register and in the THR (if any) are completely transmitted (including the programmed number of stop bits) if the transmitter is not enabled. This feature can be used to au-

tomatically terminate the transmission as follows:

1. Program auto-reset mode: MR2[5] = 1.
2. Enable transmitter.
3. Assert RTSN via command.
4. Send message.
5. Disable transmitter after the last character of the message is loaded in the THR.
6. The last character will be transmitted and RTSN will be reset one bit time after the last stop bit.

Table 2. Register Bit Formats

Bit 7	Bit 6	Bit 5	Bit 4	Bit 3	Bit 2	Bit 1	Bit 0
MR1 (Mode Register 1)							
RxRT Control	RxINT Select	Error Mode	Parity Mode		Parity Type	Bits per Character	
0 = no 1 = yes	0 = RxRDY 1 = FFULL	0 = Char 1 = Block	00 = With parity 01 = Force parity 10 = No parity 11 = Special mode		0 = Even 1 = Odd	00 = 5 01 = 6 10 = 7 11 = 8	
MR2 (Mode Register 2)							
Channel Mode		TxRTS Control	CTS Enable Tx	Stop Bit Length*			
00 = Normal 01 = Auto echo 10 = Local loop 11 = Remote loop		0 = No 1 = Yes	0 = No 1 = Yes	0 = 0.563 1 = 0.625 2 = 0.688 3 = 0.750	4 = 0.813 5 = 0.875 6 = 0.938 7 = 1.000	8 = 1.563 9 = 1.625 A = 1.688 B = 1.750	C = 1.813 D = 1.875 E = 1.938 F = 2.000
NOTE: *Add 0.5 to values shown for 0-7 if channel is programmed for 5 bits/character.							
CSR (Clock Select Register)							
Receiver Clock Select				Transmitter Clock Select			
See Text				See Text			
CR (Command Register)							
Miscellaneous Commands				Disable Tx	Enable Tx	Disable Rx	Enable Rx
See Text				0 = No 1 = Yes	0 = No 1 = Yes	0 = No 1 = Yes	0 = No 1 = Yes
SR (Channel Status Register)							
Received Break	Framing Error	Parity Error	Overrun Error	TxEIT	TxRDY	FFULL	RxDY
0 = No 1 = Yes	0 = No 1 = Yes	0 = No 1 = Yes	0 = No 1 = Yes	0 = No 1 = Yes	0 = No 1 = Yes	0 = No 1 = Yes	0 = No 1 = Yes
NOTE: *These status bits are appended to the corresponding data character in the receive FIFO. A read of the status register provides these bits [7:5] from the top of the FIFO together with bits [4:0]. These bits are cleared by a reset error status command. In character mode they are reset when the corresponding data character is read from the FIFO.							
ACR (Auxiliary Control Register)							
BRG Set Select	Counter/Timer Mode and Source			Power-Down Mode	MPO Pin Function Select		
0 = Set 1 1 = Set 2	See Text			0 = On 1 = Off	000 = RTSN 001 = C/TO 010 = TxC (1X) 011 = TxC (16X)	100 = RxC (1X) 101 = RxC (16X) 110 = TxRDY 111 = RxRDY/FFULL	

Universal Asynchronous Receiver/Transmitter (UART)

2691

Table 2. Register Bit Formats (Continued)

Bit 7	Bit 6	Bit 5	Bit 4	Bit 3	Bit 2	Bit 1	Bit 0
ISR (Interrupt Status Register)							
MPI Pin Change	MPI Pin Current State	Not used	Counter Ready	Delta Break	RxRDY/FFULL	TxEINT	TxRDY
0 = No 1 = Yes	0 = Low 1 = High		0 = No 1 = Yes	0 = No 1 = Yes	0 = No 1 = Yes	0 = No 1 = Yes	0 = No 1 = Yes
IMR (Interrupt Mask Register)							
MPI Change Interrupt	MPI Level Interrupt	Not used	Counter Ready Int	Delta Break Interrupt	RxRDY/FFULL Interrupt	TxEINT Interrupt	TxRDY Interrupt
0 = Off 1 = On	0 = Off 1 = On		0 = Off 1 = On	0 = Off 1 = On	0 = Off 1 = On	0 = Off 1 = On	0 = Off 1 = On
CTUR (Counter/Timer Upper Register)							
C/T[15]	C/T[14]	C/T[13]	C/T[12]	C/T[11]	C/T[10]	C/T[9]	C/T[8]
CTLR (Counter/Timer Lower Register)							
C/T[7]	C/T[6]	C/T[5]	C/T[4]	C/T[3]	C/T[2]	C/T[1]	C/T[0]

MR2[4] – Clear-to-Send Control

The state of this bit determines if the CTSN input (MPI) controls the operation of the transmitter. If this bit is 0, CTSN has no effect on the transmitter. If this bit is a 1, the transmitter checks the state of CTSN each time it is ready to send a character. If it is asserted (low), the character is transmitted. If it is negated (high), the TxD output remains in the marking state and the transmission is delayed until CTSN goes low. Changes in CTSN while a character is being transmitted do not affect the transmission of that character. This feature can be used to prevent overrun of a remote receiver.

MR2[3:0] – Stop Bit Length Select

This field programs the length of the stop bit appended to the transmitted character. Stop bit lengths of 9/16 to 1 and 1–9/16 to 2 bits, in increments of 1/16 bit, can be programmed for character lengths of 6, 7, and 8 bits. For a character length of 5 bits, 1–1/16 to 2 stop bits can be programmed in increments of 1/16 bit. In all cases, the receiver only checks for a mark condition at the center of the first stop bit position (one bit time after the last data bit, or after the parity bit if parity is enabled). If an external 1X clock is used for the transmitter, MR2[3] = 0 selects one stop bit and MR2[3] = 1 selects two stop bits to be transmitted.

CSR – Clock Select Register

CSR[7:4] – Receiver Clock Select

This field selects the baud rate clock for the receiver as shown in Table 3. The baud rates listed are for a 3.6864MHz crystal or external clock.

CSR[3:0] – Transmitter Clock Select

This field selects the baud rate clock for the transmitter. The field definition is as shown in Table 3.

Table 3. Baud Rate Selection

CSR[3:0]/[7:4]	ACR[7] = 0	ACR[7] = 1
0 0 0 0	50	50
0 0 0 1	110	110
0 0 1 0	134.5	134.5
0 0 1 1	200	150
0 1 0 0	300	300
0 1 0 1	600	600
0 1 1 0	1,200	1,200
0 1 1 1	1,050	1,050
1 0 0 0	2,400	2,400
1 0 0 1	4,800	4,800
1 0 1 0	7,200	1,800
1 0 1 1	9,600	9,600
1 1 0 0	38.4k	19.2k
1 1 0 1	Timer	Timer
1 1 1 0	MPI – 16X	MPI – 16X
1 1 1 1	MPI – 1X	MPI – 1X

The receiver clock is always a 16X clock, except for CSR[7:4] = 1111.

CR – Command Register

CR is used to write commands to the UART. Multiple commands can be specified in a single write to CR as long as the commands are non-conflicting, e.g., the enable transmitter and reset transmitter commands cannot be specified in a single command word.

CR[7:4] – Miscellaneous Commands

The encoded value of this field may be used to specify a single command as follows:

- 0000 No command.
- 0001 Reset MR pointer. Causes the MR pointer to point to MR1.
- 0010 Reset receiver. Resets the receiver as if a hardware reset had been applied. The receiver is disable and the FIFO is flushed.
- 0011 Reset transmitter. Resets the transmitter as if a hardware reset had been applied
- 0100 Reset error status. Clears the received break, parity error, framing error, and overrun error bits in the status register (SR[7:4]). Used in character mode to clear OE status (although RB, PE, and FE bits will also be cleared), and in block mode to clear all error status after a block of data has been received.
- 0101 Reset break change interrupt. Causes the break detect change bit in the interrupt status register (ISR[3]) to be cleared to zero.
- 0110 Start break. Forces the TxD output low (spacing). If the transmitter is empty, the start of the break condition will be delayed up to two bit times. If the transmitter is active, the break begins when transmission of the character is completed. If a character is in the THR, the start of break is delayed until that character or any others loaded after it have been transmitted (TxEMT must be true before break begins). The transmitter must be enabled to start a break.

Universal Asynchronous Receiver/Transmitter (UART)

2691

- 0111 Stop break. The TxD line will go high (marking) within two bit times. TxD will remain high for one bit time before the next character, if any, is transmitted.
- 1000 Start C/T. In counter or timer modes, causes the contents of CTUR/CTLR to be preset into the counter/timer and starts the counting cycle. In timer mode, any counting cycle in progress when the command is issued is terminated. In counter mode, has no effect unless a stop C/T command was issued previously.
- 1001 Stop counter. In counter mode, stops operation of the counter/timer, resets the counter ready bit in the ISR, and forces the MPO output high if it is programmed to be the output of the C/T. In timer mode, resets the counter ready bit in the ISR but has no effect on the counter/timer itself or on the MPO output.
- 1010 Assert RTSN. Causes the RTSN output (MPO) to be asserted (low).
- 1011 Negate RTSN. Causes the RTSN output (MPO) to be negated (high).
- 1100 Reset MPI change interrupt. Causes the MPI change bit in the interrupt status register (ISR[7]) to be cleared to zero.
- 1101 Reserved.
- 111x Reserved.

CR[3] – Disable Transmitter

This command terminates operation and resets the TxRDY and TxEMT status bits. However, if a character is being transmitted or if a character is in the THR when the transmitter is disabled, the transmission of the character(s) is completed before assuming the inactive state.

CR[2] – Enable Transmitter

Enables operation of the channel A transmitter. The TxRDY status bit will be asserted.

CR[1] – Disable Receiver

This command terminates operation of the receiver immediately; a character being received will be lost. The command has no effect on the receiver status bits or any other control registers. If the special wake-up mode is programmed, the receiver operates even if it is disabled (see Wake-up Mode).

CR[0] – Enable Receiver

Enables operation of the receiver. If not in the special wake-up mode, this also forces the receiver into the search for start bit state.

SR – Channel Status Register

The status register is updated while RDN is negated. Therefore, the bus interface used with

this device must not use a static RDN line. The RDN line must be pulsed to allow status register updates.

SR[7] – Received Break

This bit indicates that an all zero character of the programmed length has been received without a stop bit. Only a single FIFO position is occupied when a break is received; further entries to the FIFO are inhibited until the RxD line returns to the marking state for at least one half bit time (two successive edges of the internal or external 1X clock).

When this bit is set, the change in break bit in the ISR (ISR[3]) is set. ISR[3] is also set when the end of the break condition, as defined above, is detected.

The break detect circuitry is capable of detecting breaks that originate in the middle of a received character. However, if a break begins in the middle of a character, it must last until the end of the next character time in order for it to be detected.

SR[6] – Framing Error (FE)

This bit, when set, indicates that a stop bit was not detected when the corresponding data character in the FIFO was received. The stop bit check is made in the middle of the first stop bit position.

SR[5]– Parity Error (PE)

This bit is set when the with parity or force parity mode is programmed and the corresponding character in the FIFO was received with incorrect parity. In special wake-up mode, the parity error bit stores the received A/D bit.

SR[4] – Overrun Error (OE)

This bit, when set, indicates that one or more characters in the received data stream have been lost. It is set upon receipt of a new character when the FIFO is full and a character is already in the receive shift register waiting for an empty FIFO position. When this occurs, the character in the receive shift register (and its break detect, parity error and framing error status, if any) is lost. This bit is cleared by a reset error status command.

SR[3] – Transmitter Empty (TxEMT)

This bit will be set when the transmitter under- runs, i.e., both the transmit holding register (THR) and the transmit shift register are empty. However, this bit is not set until at least one character has been transmitted. It is set after transmission of the last stop bit of a character, if no character is in the THR awaiting transmission. It is reset when the THR is loaded by the CPU, or when the transmitter is disabled.

SR[2] – Transmitter Ready (TxRDY)

This bit, when set, indicates that the THR is empty and ready to be loaded with a character. This bit is cleared when the THR is loaded by

the CPU and is set when the character is transferred to the transmit shift register. TxRDY is reset when the transmitter is disabled and is set when the transmitter is first enabled, e.g., characters loaded in the THR while the transmitter is disabled will not be transmitted.

SR[1] – FIFO Full (FFULL)

This bit is set when a character is transferred from the receive shift register to the receive FIFO and the transfer causes the FIFO to become full, i.e., all three FIFO positions are occupied. It is reset when the CPU reads the FIFO and there is no character in the receive shift register. If a character is waiting in the receive shift register because the FIFO is full, FFULL will be reset by the CPU read and then set by the transfer of the character to the FIFO, which causes all three FIFO positions to be occupied.

SR[0] – Receiver Ready (RxRDY)

This bit indicates that a character has been received and is waiting in the FIFO to be read by the CPU. It is set when the character is transferred from the receive shift register to the FIFO and reset when the CPU reads the RHR, and no more characters are in the FIFO.

ACR – Auxiliary Control Register

ACR[7] – Baud Rate Generator Set Select

This bit selects one of two sets of baud rates generated by the BRG.

Set 1: 50, 110, 134.5, 200, 300, 600, 1.05k, 1.2k, 2.4k, 4.8k, 7.2k, 9.6k, and 38.4k baud.

Set 2: 75, 110, 134.5, 150, 300, 600, 1.2k, 1.8k, 2.0k, 2.4k, 4.8k, 9.6k, and 19.2k baud.

The selected set of rates is available for use by the receiver and transmitter. See Table 4 for characteristics of the BRG.

ACR[6:4] – Counter/Timer Mode and Clock Source Select

This field selects the operating mode of the counter/timer and its clock source as follows:

ACR [6:4]	Mode	Clock Source
0 0 0	Counter	MPI pin
0 0 1	Counter	MPI pin divided by 16
0 1 0	Counter	TxC–1X clock of the transmitter
0 1 1	Counter	Crystal or external clock (X1/CLK) divided by 16
1 0 0	Timer	MPI pin
1 0 1	Timer	MPI pin divided by 16
1 1 0	Timer	Crystal or external clock (X1/CLK)
1 1 1	Timer	Crystal or external clock (X1/CLK) divided by 16

Universal Asynchronous Receiver/Transmitter (UART)

2691

ACR[3] – Power-Down Mode Select

This bit, when set to zero, selects the power-down mode. In this mode, the 2691 oscillator is stopped and all functions requiring this clock are suspended. The contents of all registers are saved. It is recommended that the transmitter and receiver be disabled prior to placing the 2691 in this mode. Note that this bit must be set to a logic 1 after reset.

When the power-down mode is enabled, internal circuitry forces the X1/CLK pin to the low state and the X2 pin to the high state. If an external clock is being used to drive the device, it is recommended that the clock source be three-stated or forced low while the UART is in power-down mode in order to prevent the clock driver from being short circuited.

Table 4. BRG Characteristics

Crystal or Clock = 3.6864MHz

Nom Rate (Baud)	Actual 16X* Clock (kHz)	Error (%)
50	0.8	0
75	1.2	0
110	1.759	-0.069
134.5	2.153	0.059
150	2.4	0
200	3.2	0
300	4.8	0
600	9.6	0
1050	16.756	-0.260
1200	19.2	0
1800	28.8	0
2000	32.056	0.175
2400	38.4	0
4800	76.8	0
7200	115.2	0
9600	153.6	0
19.2k	307.2	0
38.4k	614.4	0

*Duty cycle of 16X clock is 50% ±1%

ACR[2:0] – MPO Output Select

This field programs the MPO output pin to provide one of the following:

- 000 Request-to-send active-low output (RTSN). This output is asserted and negated via the command register. RTSN can be programmed to be automatically reset after the character in the transmitter is completely shifted out or when the receiver FIFO and receiver shift register are full using MR2[5] and MR1[7], respectively.
- 001 The counter/timer output. In the timer mode, this output is a square wave with a period of twice the value (in clock periods) of the contents of the CTUR and CTLR. In the counter mode, the output remains high until the terminal count is reached, at which time it goes low. The output returns to the high state when the counter is stopped by a stop counter command.

- 010 The 1X clock for the transmitter, which is the clock that shifts the transmitted data. If data is not being transmitted, a non-synchronized 1X clock is output.
- 011 The 16X clock for the transmitter. This is the clock selected by CSR[3:0] = 1111.
- 100 The 1X clock for the receiver, which is the clock that samples the received data. If data is not being received, a non-synchronized 1X clock is output.
- 101 The 16X clock for the receiver. This is the clock selected by CSR[7:4], and is a 1X clock if CSR[7:4] = 1111.
- 110 The transmitter register empty signal, which is the complement of SR[2]. Active low output.
- 111 The receiver ready or FIFO full signal (complement of ISR[2]). Active-low output.

ISR – Interrupt Status Register

This register provides the status of all potential interrupt sources. The contents of this register are masked by the interrupt mask register (IMR). If a bit in the ISR is a '1' and the corresponding bit in the IMR is also a '1', the INTRN output is asserted (low). If the corresponding bit in the IMR is a zero, the state of the bit in the ISR has no effect on the INTRN output. Note that the IMR does not mask the reading of the ISR; the true status is provided regardless of the contents of the IMR. This register is cleared when the device is reset.

ISR[7] – MPI Change-of-State

This bit is set when a change-of-state occurs at the MPI input pin. It is reset by a reset change interrupt command.

ISR[6] – MPI Current State

This bit provides the current state of the MPI pin. This information is latched and reflects the state of the pin at the leading edge of the ISR ready cycle.

ISR[4] – Counter Ready

In the counter mode of operation, this bit is set when the counter reaches terminal count and is reset when the counter is stopped by a stop counter command.

In the timer mode, this bit is set once each cycle of the generated square wave (every other time the C/T reaches zero count). The bit is reset by a stop counter command. The command, however, does not stop the C/T.

ISR[3] – Change in Break

This bit, when set, indicates that the receiver has detected the beginning or end of a received

break. It is reset when the CPU issues a reset break change interrupt command.

ISR[2] – Receiver Ready or FIFO Full

The function of this bit is programmed by MR1[6]. If programmed as receiver ready, it indicates that a character has been received and is waiting in the FIFO to be read by the CPU. It is set when the character is transferred from the receive shift register to the FIFO and reset when the CPU reads the receiver FIFO. If the FIFO contains more characters, the bit will be set again after the FIFO is read. If programmed as FIFO full, it is set when a character is transferred from the receive holding register to the receive FIFO and the transfer causes the FIFO to become full, i.e., all three FIFO positions are occupied. It is reset when the FIFO is read and there is no character in the receive shift register. If there is a character waiting in the receive shift register because the FIFO is full, the bit is set again when the waiting character is transferred into the FIFO.

ISR[1] – Transmitter Empty

This bit is a duplicate of TxEMT (SR[3]).

ISR[0] – Transmitter Ready

This bit is a duplicate of TxRDY (SR[2]).

IMR – Interrupt Mask Register

The programming of this register selects which bits in the ISR cause an interrupt output. If a bit in the ISR is a '1' and the corresponding bit in the IMR is a '1', the INTRN output is asserted (low). If the corresponding bit in the IMR is a zero, the state of the bit in the ISR has no effect on the INTRN output. Note that the IMR does not mask reading of the ISR.

CTUR and CTLR – Counter/Timer Registers

The CTUR and CTLR hold the eight MSBs and eight LSBs, respectively, of the value to be used by the counter/timer in either the counter or timer modes of operation. The minimum value which may be loaded is 0002₁₆.

In the timer (programmable divider) mode, the C/T generates a square wave whose period is twice the value (in clock periods) of the CTUR and CTLR. If the value in CTUR or CTLR is changed, the current half-period will not be affected, but subsequent half-periods will be.

The counter ready status bit (ISR[4]) is set once each cycle of the square wave. The bit is reset by a stop counter command. The command, however, does not stop the C/T. The generated square wave is output on MPO if it is programmed to be the C/T output.

In the counter mode, the C/T counts down the number of pulses loaded in CTUR and CTLR. Counting begins upon receipt of a start C/T

Universal Asynchronous Receiver/Transmitter (UART)

2691

command. Upon reaching the terminal count, the counter ready interrupt bit (ISR[4]) is set. The counter continues counting past the terminal count until stopped by the CPU. If MPO is programmed to be the output of the C/T, the out-

put remains high until the terminal count is reached, at which time it goes low.

The output returns to the high state and ISR[4] is cleared when the counter is stopped by a stop counter command. The CPU may change the

values of CTUR and CTLR at any time, but the new count becomes effective only on the next start counter command. If new values have not been loaded, the previous values are preserved and used for the next count cycle.

ABSOLUTE MAXIMUM RATINGS¹

SYMBOL	PARAMETER	RATING	UNIT
T _{STG}	Storage temperature range	-65 to +150	°C
V _{CC}	Voltage from V _{CC} to GND ³	-0.5 to +7.0	V
V _S	Voltage from any pin to ground ³	-0.5 to V _{CC} + 10%	V

RECOMMENDED OPERATING CONDITIONS

SYMBOL	PARAMETER	LIMITS			UNIT
		Min	Nom	Max	
V _{CC}	Supply voltage	4.5	5.0	5.5	V
V _{IH}	High-level input voltage (except X1/CLK)	2.0			V
V _{IH}	High-level input voltage (X1/CLK)	4.0			V
V _{IL}	Low-level input voltage			0.8	V
I _{OL}	Low-level output current			2.4	mA
I _{OH}	High-level output current			-400	μA
T _A	Operating free air temperature range ²	-55		+125	°C

Universal Asynchronous Receiver/Transmitter (UART)

2691

DC ELECTRICAL CHARACTERISTICS^{4, 5}, $-55^{\circ}\text{C} \leq T_A \leq 125^{\circ}\text{C}$, $4.5\text{V} \leq V_{CC} \leq 5.5\text{V}$

SYMBOL	PARAMETER	TEST CONDITIONS	LIMITS			UNIT
			Min	Typ ⁶	Max	
V_{OL} V_{OH} ⁷	Output low voltage Output high voltage (except open drain outputs)	$I_{OL} = \text{MAX}$ $I_{OH} = \text{MAX}$	2.4		0.4	V V
	Input leakage current	$V_{IN} = 0 \text{ to } V_{CC}$	-10		10	μA
I_{OZH}	Output off current, High, 3-State Data Bus	$V_{IN} = V_{CC}$	-10		10	μA
I_{OZL}	Output off current, Low, 3-State Data Bus	$V_{IN} = 0$	-10		10	μA
I_{X1L}	X1/CLK low input current	$V_{IN} = 0$, X2 floated	-100	-30	0	μA
I_{X1H}	X1/CLK high input current	$V_{IN} = V_{CC}$, X2 floated	0	30	100	μA
I_{X2L}	X2 low output current	$V_{OUT} = 0$, X1/CLK = V_{CC}	-100			μA
I_{X2H}	X2 high output current	$V_{OUT} = V_{CC}$, X1/CLK = 0V			100	μA
I_{CCA}	Power supply current, active			1.0	3.0	mA
I_{CCD}	Power down current				500	μA

NOTES:

- Stresses above those listed under Absolute Maximum Ratings may cause permanent damage to the device. This is a stress rating only and functional operation of the device at these or any other condition above those indicated in the operation section of this specification is not implied.
- For operating at elevated temperature, the device must be derated based on +150°C maximum junction temperature.
- This product includes circuitry specifically designed for the protection of its internal devices from damaging effects of excessive static charge. Nonetheless, it is suggested that conventional precautions be taken to avoid applying any voltages larger than the rated maxima.
- All voltage measurements are referenced to ground (GND). For testing, all input signals swing between 0V and 2.8V with a transition time of 20ns max. For X1/CLK, this swing is between 0.4V and 4.0V. All time measurements are referenced at input voltages of 0.8V and 2V and output voltages of 0.8V and 2V as appropriate.
- Typical values are at +25°C, typical supply voltages, and typical processing parameters.
- Test condition for outputs: $C_L = 150\text{pF}$, except interrupt outputs. Test conditions for interrupt outputs: $C_L = 50\text{pF}$, $R_L = 2.7\text{kohms}$ to V_{CC} .
- Timing is illustrated and referenced to the WRN and RDN inputs. The device may also be operated with CEN as the 'strobing' input. In this case, all timing specifications apply referenced to the falling and rising edges of CEN. CEN and RDN (also CEN and WRN) are ORed internally. As a consequence, this signal asserted last initiates the cycle and the signal negated first terminates the cycle.
- If CEN is used as the 'strobing' input, this parameter defines the minimum high time between one CEN and the next. The RDN signal must be negated for t_{PWD} guarantee that any status register changes are valid.
- Consecutive write operations to the command register require at least three rising edges of the X1 clock between writes.
- These parameters are guaranteed by design but are not 100% tested.

Universal Asynchronous Receiver/Transmitter (UART)

2691

AC ELECTRICAL CHARACTERISTICS^{4, 5, 6} $-55^{\circ}\text{C} \leq T_A \leq 125^{\circ}\text{C}$, $4.5\text{V} \leq V_{CC} \leq 5.5\text{V}$

SYMBOL	PARAMETER	LIMITS			UNIT
		Min	Typ	Max	
Reset timing (Figure 1)					
t_{RES}	Reset pulse width	100			ns
Bus timing (Figure 2)⁷					
t_{AS}	A0–A2 setup time to RDN, WRN low	10			ns
t_{AH}	A0–A2 hold time from RDN, WRN high	0			ns
t_{CS}	CEN setup time to RDN, WRN low	0			ns
t_{CH}	CEN hold time from RDN, WRN high	0			ns
t_{RW}	WRN, RDN pulse width	150			ns
t_{D0}	Data valid after RDN low			125	ns
t_{Df}	Data bus floating after RDN high			110	ns
t_{DS}	Data setup time before WRN high	50			ns
t_{DH}	Data hold time after WRN high	30			ns
t_{RWD}	Time between reads and/or writes ^{9, 10}	150			ns
MPI and MPO timing (Figure 3)⁷					
t_{PS}	MPI input setup time before RDN low	30			ns
t_{PH}	MI input hold time after RDN low	30			ns
t_{PD}	MPO output valid after WRN high			370	ns
Interrupt timing (Figure 4)					
t_{IR}	INTRN negated Read RHR (RxRDY/FFULL interrupt) Write THR (TxRDY, TxEMT interrupt) Reset command (break change interrupt) Reset command (MPI change interrupt) Stop C/T command (counter interrupt) Write IMR (clear of interrupt mask bit)			370 370 370 370 370 270	ns ns ns ns ns ms
Clock timing (Figure 5)					
t_{CLK}	X1/CLK high or low time	100			ns
f_{CLK}	X1/CLK frequency	2.0	3.6864	4.0	MHz
t_{CTC}	Counter/timer clock high or low time	100			ns
f_{CTC}	Counter/timer clock frequency	0 ¹⁰		4.0	MHz
t_{RX}	RxC high or low time	220			ns
f_{RX}	RxC frequency (16X) RxC frequency (1X)	0 ¹⁰ 0 ¹⁰		2.0 1.0	MHz MHz
t_{TX}	TxC high or low time	220			ns
f_{TX}	TxC frequency (16X) TxC frequency (1X)	0 ¹⁰ 0 ¹⁰		2.0 1.0	MHz MHz
Transmitter timing (Figure 6)					
t_{TXD}	TxD output delay from TxC low			350	ns
t_{TCS}	TxC output delay from TxD output data	0		150	ns
Receiver timing (Figure 7)					
t_{RXS}	RxD data setup time to RxC high	100			ns
t_{RXH}	RxD data hold time from RxC high	100			ns

Universal Asynchronous Receiver/Transmitter (UART)

2691

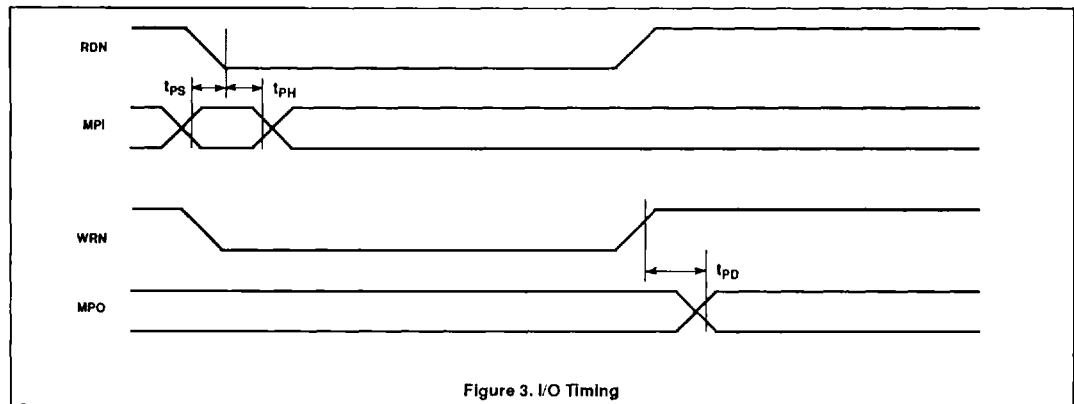
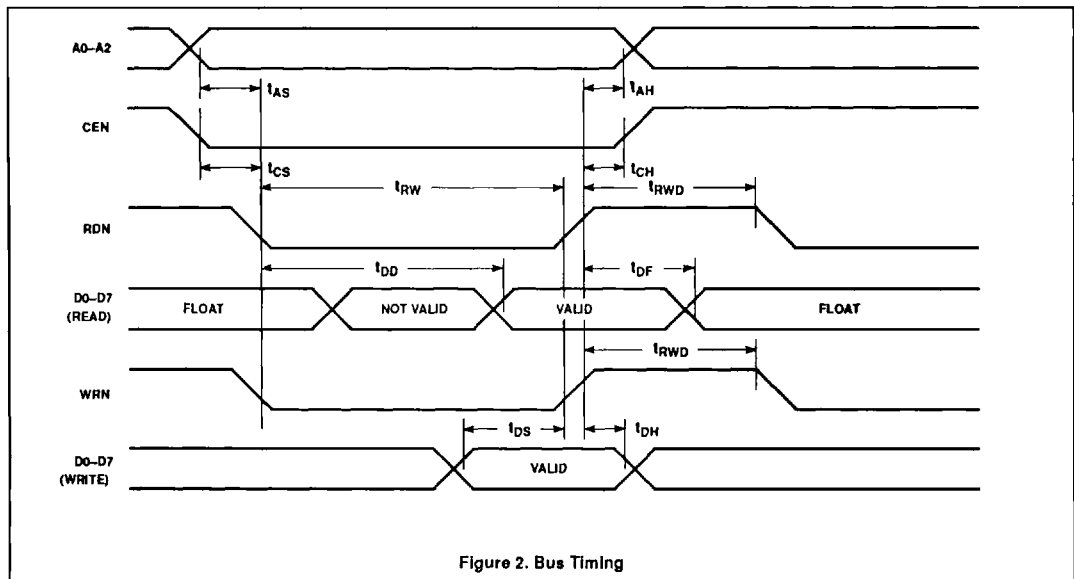
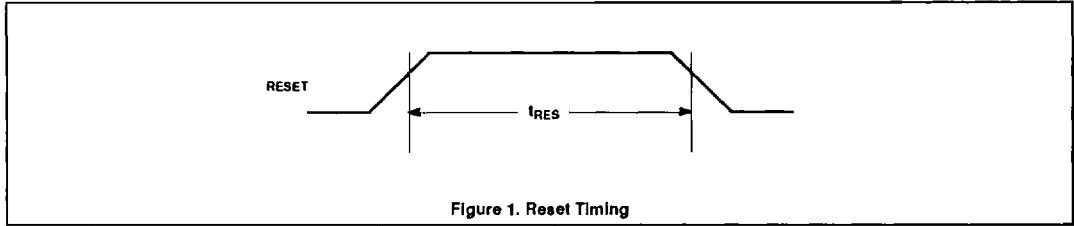

Universal Asynchronous Receiver/Transmitter (UART)

2691

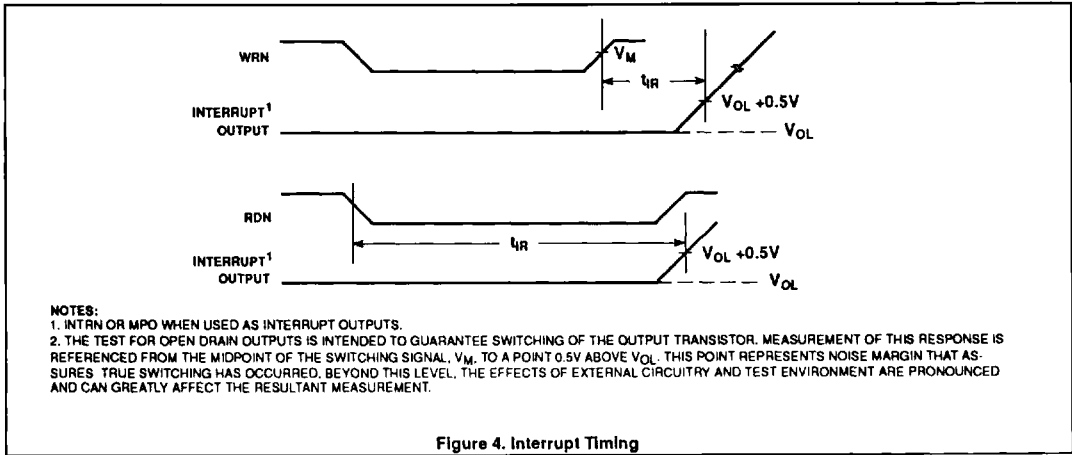

Figure 4. Interrupt Timing

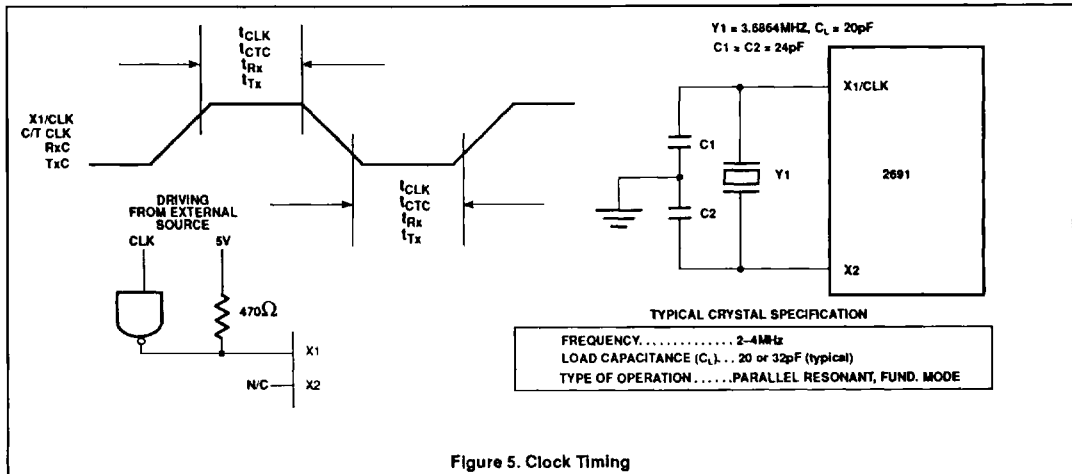

Figure 5. Clock Timing

Universal Asynchronous Receiver/Transmitter (UART)

2691

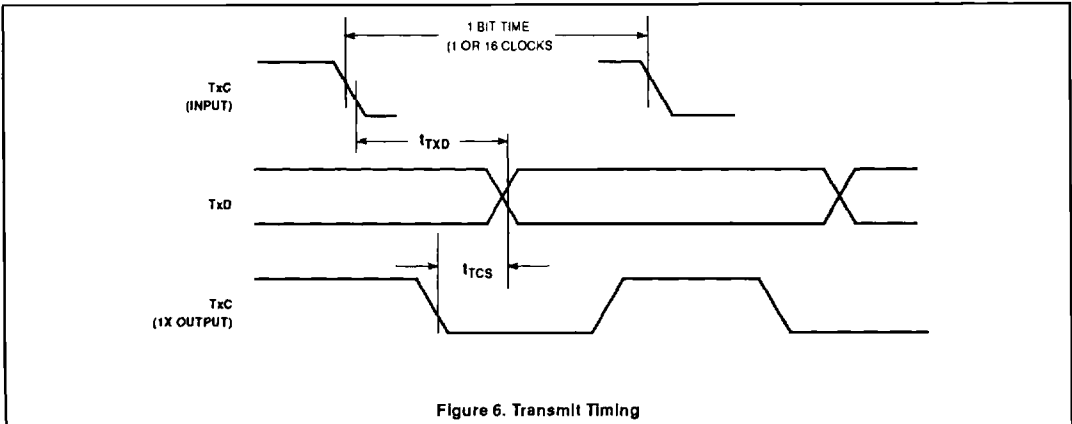

Figure 6. Transmit Timing

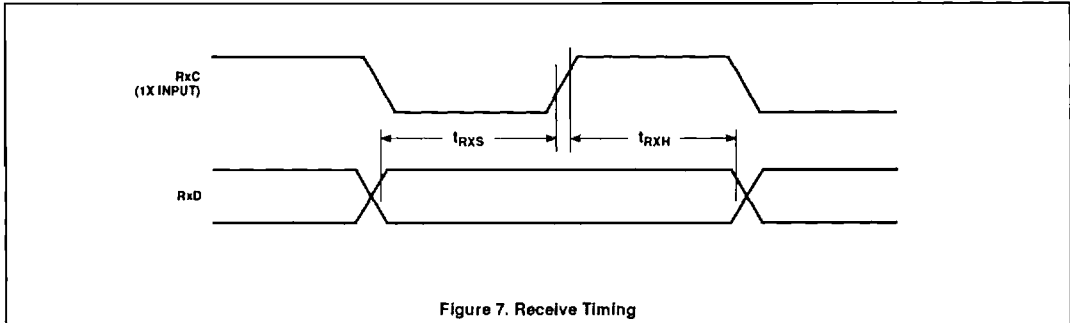
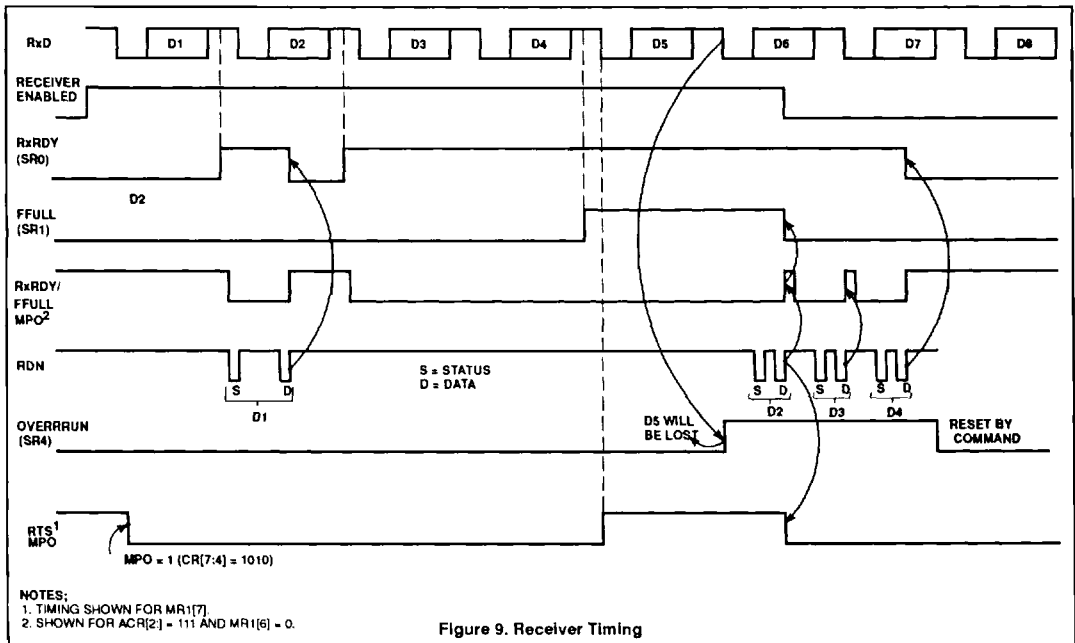
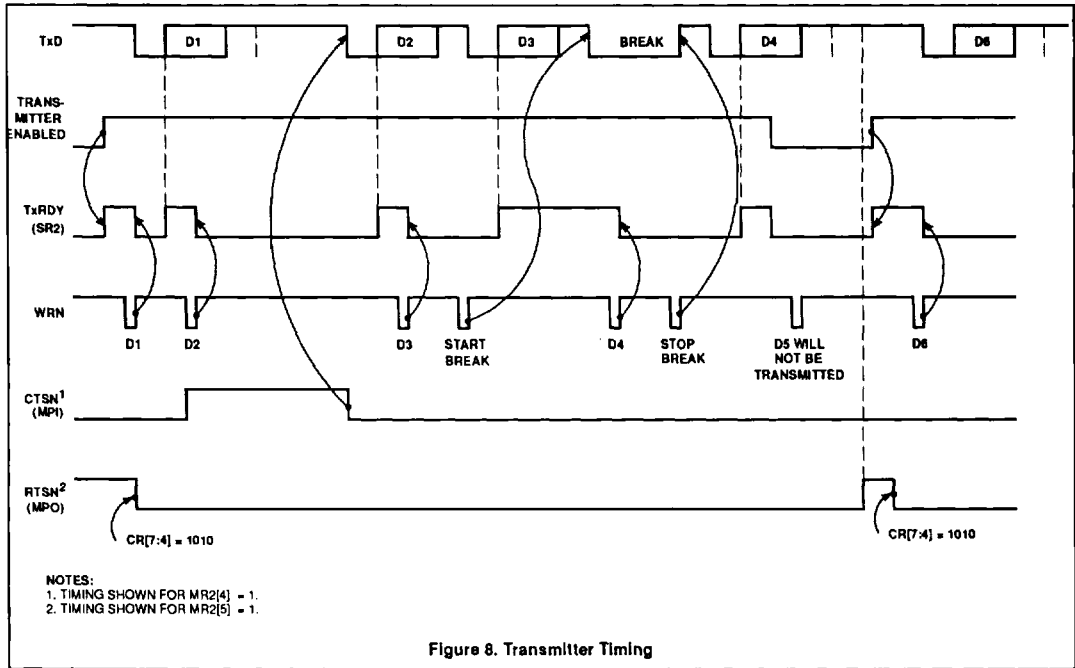

Figure 7. Receive Timing

Universal Asynchronous Receiver/Transmitter (UART)

2691



Universal Asynchronous Receiver/Transmitter (UART)

2691

