

PIN CONFIGURATION

ML2039
8-Pin PDIP (P08)

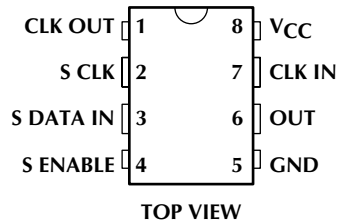

PIN DESCRIPTION

PIN	NAME	FUNCTION	PIN	NAME	FUNCTION
1	CLK OUT	Output of the internal high frequency clock generator. $f_{\text{CLK OUT}} = \frac{1}{2}f_{\text{CLK IN}}$.	5	GND	Ground reference for the IC and reference for OUT.
2	S CLK	Serial data clock input. Serial data is clocked into the shift register on falling edges of S CLK.	6	OUT	Sine wave output. The amplitude of the sine wave will vary $\pm 1\text{V}$ around a 2.5V DC level.
3	S DATA IN	Serial data input for programming the output frequency.	7	CLK IN	Input of the internal high frequency clock generator. This pin is either driven from an external clock input or connected to a crystal for use with the internal oscillator.
4	S ENABLE	Serial interface enable control. A logic high on this pin allows data to be entered into the latch.	8	V _{CC}	Power supply for the IC.

ABSOLUTE MAXIMUM RATINGS

Absolute maximum ratings are those values beyond which the device could be permanently damaged. Absolute maximum ratings are stress ratings only and functional device operation is not implied.

V_{CC}	7V
Voltage on any other pin	GND - 0.3V to $V_{CC} + 0.3V$
Input Current	$\pm 25mA$
Junction Temperature	150°C
Storage Temperature Range	-65°C to 150°C

Lead Temperature (Soldering, 10 sec)	260°C
Thermal Resistance (θ_{JA})	110°C/W

OPERATING CONDITIONS

Temperature Range	
ML2039CP	0°C to 70°C
ML2039IP	-40°C to 85°C
V_{CC} Range	4.75V to 5.25V

ELECTRICAL CHARACTERISTICS

Unless otherwise specified, $V_{CC} = 4.75V$ to $5.25V$, CLK IN = 25.6MHz (crystal) or 32MHz (external clock), $C_L = 50pF$, $R_L = 1k\Omega$, $T_A =$ Operating Temperature Range (Note 1)

SYMBOL	PARAMETER	CONDITIONS	MIN	TYP	MAX	UNITS	
OUTPUT							
HD	Harmonic Distortion (2nd and 3rd Harmonic)	20Hz to 31.25kHz			-45	dB	
		31.25kHz to 500kHz			-40	dB	
SND	Signal to Noise + Distortion	1kHz to 31.25kHz, $f_{OUT} BW < 31.25kHz$			-45	dB	
		31.35kHz to 500kHz, $f_{OUT} BW < 500kHz$			-40	dB	
PSRR	Gain Error	$f_{OUT} < 125kHz$, $V_{CC} = 5V$	C Suffix			± 0.15	dB
		$f_{OUT} < 125kHz$, $V_{CC} = 5V$	I Suffix			± 0.25	dB
		$125kHz < f_{OUT} < 500kHz$, $V_{CC} = 5V$	Both			± 0.5	dB
		200mV _{P-P} , $f_{OUT} = 0 - 100kHz$			-40		dB
	DC Output Voltage		2.4		2.6	V	
	Peak-to-Peak Output Voltage		1.88	2.0	2.12	V_{P-P}	

OSCILLATOR

	CLK IN Input Low Voltage				1.5	V
	CLK IN Input High Voltage		3.5			V
	CLK IN Input Low Current		-250			μA
	CLK IN Input High Current				250	μA
	CLK IN Input Capacitance			12		pF
	CLK IN Maximum Frequency	External Clock	32			MHz
	CLK OUT to CLK IN Frequency Ratio		0.49		0.51	
t_R	CLK OUT Rise Time	$C_L = 25pF$, See Timing Diagram 2			8	ns
t_F	CLK OUT Fall Time	$C_L = 25pF$, See Timing Diagram 2			8	ns

ELECTRICAL CHARACTERISTICS (Continued)

SYMBOL	PARAMETER	CONDITIONS	MIN	TYP	MAX	UNITS
LOGIC						
V_{IL}	Input Low Voltage				1.0	V
V_{IH}	Input High Voltage		$DV_{CC} - 1$			V
I_{IL}	Input Low Current		-1			μA
I_{IH}	Input High Current				1	μA
V_{OL}	Output Low Voltage	$I_{OL} = -2mA$			0.4	V
V_{OH}	Output High Voltage	$I_{OH} = 2mA$	4.0			V
$f_{S\ CLK}$	Serial Clock Frequency		0.01		10	MHz
t_{PW}	Serial CLock Pulse Width		40			ns
t_{HSD}	S CLK to S DATA IN Hold Time		10			ns
t_{SSD}	S DATA IN to S CLK Setup Time		10			ns
t_{SSENS}	S CLK to S ENABLE Setup Time		30			ns
t_{SSENH}	S ENABLE to S CLK Hold Time		50			ns
t_{DSEN}	Delay from S ENABLE to Stable Output	$f_{CLK\ IN} = 32MHz$		500		ns
SUPPLY						
I_{CC}	V_{CC} Current	$f_{CLK\ IN} = 16MHz$		35	45	mA
		$f_{CLK\ IN} = 32MHz$		40	50	mA

Note 1: Limits are guaranteed by 100% testing, sampling, or correlation with worst case test conditions.

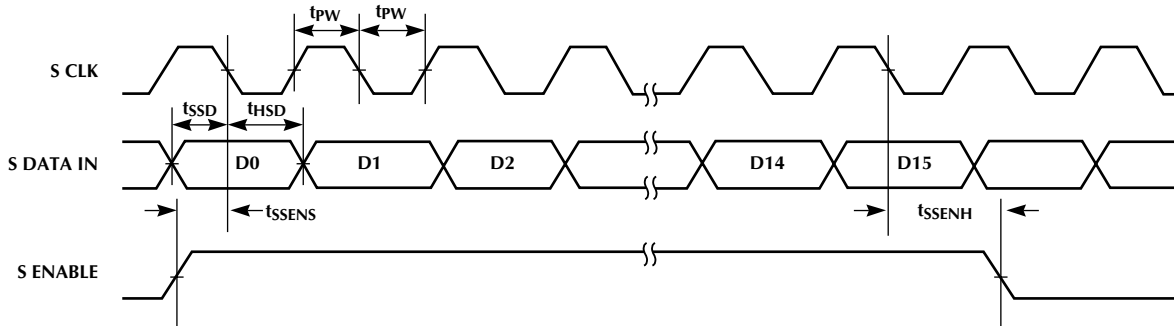

Timing Diagram 1.

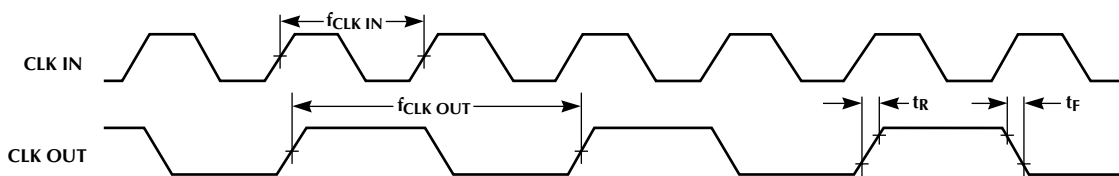

Timing Diagram 2.

FUNCTIONAL DESCRIPTION

The ML2039 is composed of a programmable frequency generator, a sine wave generator, a crystal oscillator, and a digital interface. The functional block diagram is shown in Figure 1.

PROGRAMMABLE FREQUENCY GENERATOR

The programmable frequency generator produces a digital output whose frequency is determined by a 16-bit digital word. The frequency generator is composed of a phase accumulator which is clocked at $\frac{1}{2}f_{\text{CLK IN}}$. The value stored in the data latch is added to the phase accumulator every two cycles of CLK IN. The frequency of the analog output is equal to the rate at which the accumulator overflows and is given by the following equation:

$$f_{\text{OUT}} = \frac{f_{\text{CLK IN}} \times (D15 \rightarrow D0)_{\text{DEC}}}{2^{22}} \quad (1)$$

Where (D15–D0) is the decimal value of the programming word.

The frequency resolution and the minimum frequency are the same and can be calculated using:

$$\Delta f_{\text{MIN}} = \frac{f_{\text{CLK IN}}}{2^{22}} \quad (2)$$

When $f_{\text{CLK IN}} = 25\text{MHz}$, $\Delta f_{\text{MIN}} = 5.96\text{Hz}$ ($\pm 2.98\text{Hz}$). Lower output frequencies are obtained by using a lower clock frequency.

The maximum frequency output can be easily calculated with the following equation:

$$f_{\text{OUT(MAX)}} = \frac{f_{\text{CLK IN}}}{2^6} \quad (3)$$

When $f_{\text{CLK IN}} = 25\text{MHz}$, $f_{\text{OUT(MAX)}} = 391\text{kHz}$. Higher frequencies (up to 500kHz) are obtained by using an external clock, where $25\text{MHz} < f_{\text{CLK IN}} < 32\text{MHz}$.

Due to the phase quantization nature of the frequency generator, spurious tones can be present in the output in the range of -50dB relative to fundamental. The energy from these tones is included in the signal to noise + distortion specification (SND) given in the electrical table. The frequency of these tones can be very close to the fundamental, and it is not practical to filter them out.

SINE WAVE GENERATOR

The sine wave generator is composed of a sine lookup table, an 8-bit DAC, an output smoothing filter, and an amplifier. The sine lookup table is addressed by the phase accumulator. The DAC is driven by the output of the lookup table and generates a staircase representation of a sine wave.

The output filter smooths the analog output by removing the high frequency sampling components. The resultant voltage on V_{OUT} is a sinusoid with the second and third harmonic distortion components at least 40dB below the fundamental.

The analog section is designed to operate over a frequency range of DC to 500kHz and is capable of driving $1\text{k}\Omega$, 50pF loads at the maximum amplitude of $2.0\text{V}_{\text{p.p}}$. The sine wave output is typically centered about a 2.5V DC level, so the output will swing from 1.5V to 3.5V. The output amplitude is accurate to within $\pm 0.5\text{dB}$ over the frequency range.

CRYSTAL OSCILLATOR

The crystal oscillator generates an accurate reference clock for the programmable frequency generator. The internal clock can be generated with a crystal or external clock.

If a crystal is used, it must be placed between CLK IN and GND. An on-chip oscillator will then generate the internal clock. No other external components are required. The crystal should be a parallel resonant type with a frequency between 5MHz to 25.6MHz. It should be placed physically as close as possible to CLK IN and GND, to minimize trace lengths.

The crystal must have the following characteristics:

- Parallel resonant type
- Frequency: 5MHz to 25.6MHz
- Maximum ESR: 120Ω @ 5 to 10MHz, 80Ω @ 10 to 15MHz, and 50Ω @ 15 to 25.6MHz
- Drive level: $500\mu\text{W}$
- Typical load capacitance: 18 - 20pF
- Maximum case capacitance: 7pF

The frequency of oscillation will be a function of the crystal parameters and board capacitance. In general, microprocessor crystals meet the above requirements, but it is recommended to test the selected crystal in circuit to insure proper operation. Suitable crystals can be purchased from the following suppliers:

ECS, Inc.
FOX Electronics
M-TRON Industries

An external clock can drive CLK IN directly if desired. The frequency of this clock can be anything from 0 to 32MHz. However, at clock frequencies below 5MHz, the sine wave output begins to exhibit "staircasing".

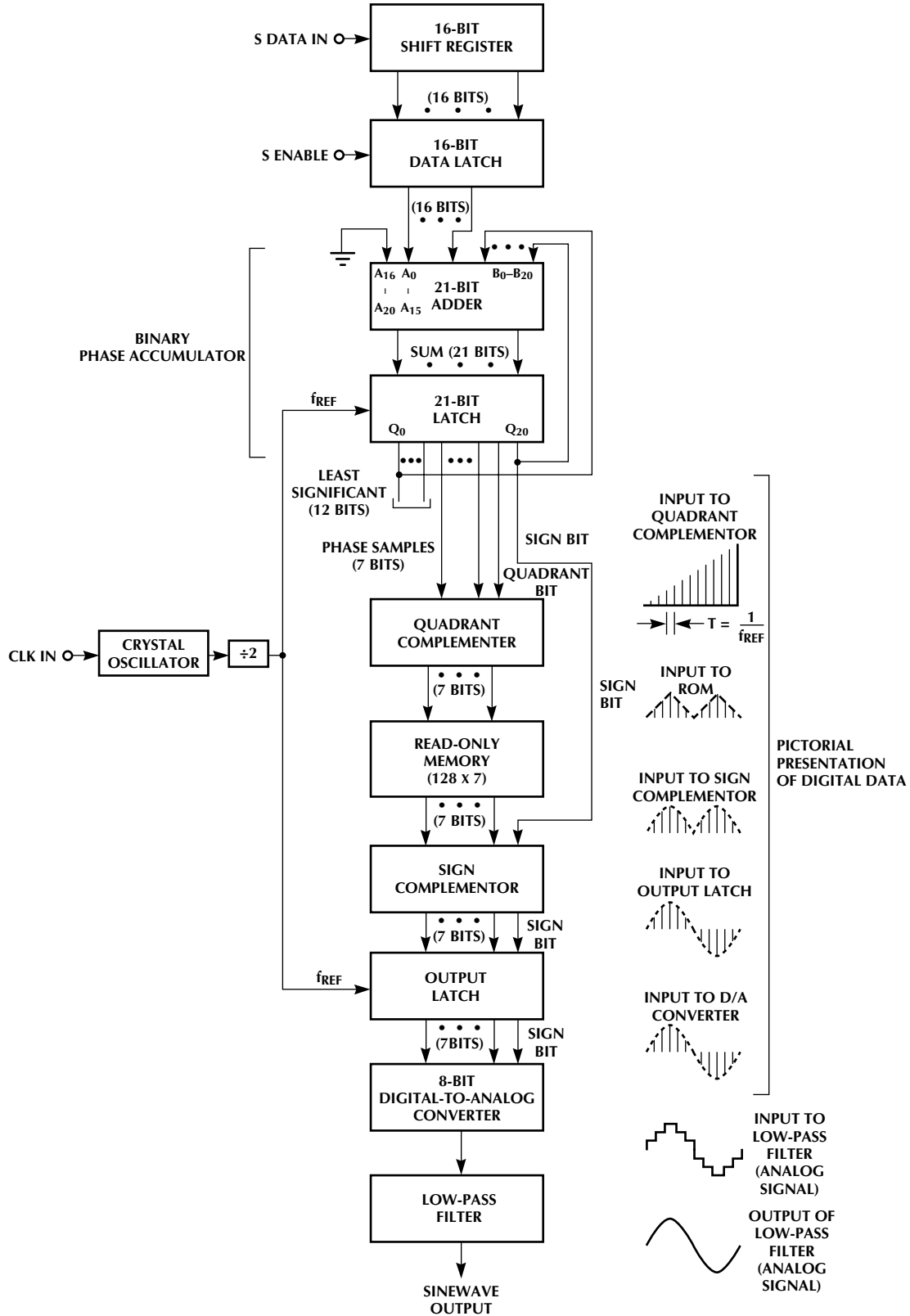

Figure 1. Detailed Block Diagram of the ML2039.

FUNCTIONAL DESCRIPTION (Continued)

The ML2039 has a clock output that can be used to drive other external devices. The CLK OUT output is a buffered output from the oscillator which runs at one half the frequency of CLK IN.

SERIAL DIGITAL INTERFACE

The digital interface consists of a shift register and data latch. The serial 16-bit data word on S DATA IN is clocked into a 16-bit shift register on falling edges of the serial shift clock, S CLK. The LSB should be shifted in first and the MSB last as shown in Timing Diagram 1. The data that has been shifted into the shift register is loaded into a 16-bit data latch on the falling edge of S ENABLE. To insure that true data is loaded into the data latch from the shift register, the S ENABLE falling edge should occur before

the S CLK transitions high to low. S ENABLE should be high while shifting data into the shift register. Note that all data is entered and latched on edges, not levels, of S CLK and S ENABLE.

Upon power up, the data in the latch is indeterminate. It is therefore recommended to initialize the frequency data as part of a power up routine.

POWER SUPPLIES

The ML2039 is powered from 5V (V_{CC}) and is referenced to GND. It is recommended that the power supply to the device should be bypassed by placing decoupling capacitors from V_{CC} to GND as physically close to the device as possible.

PHYSICAL DIMENSIONS inches (millimeters)

Package: P08
8-Pin PDIP

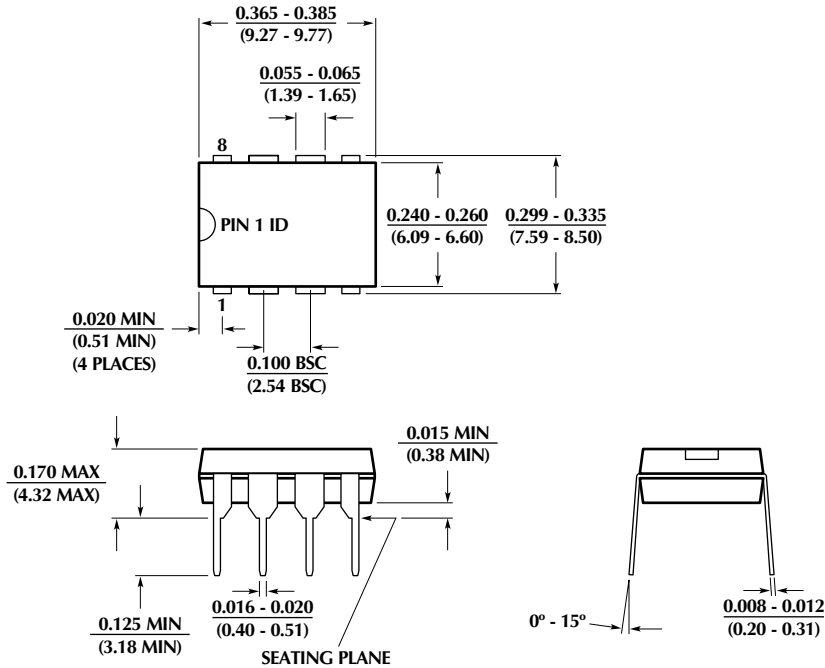

ORDERING INFORMATION

PART NUMBER	TEMPERATURE RANGE	PACKAGE
ML2039CP	0°C to 70°C	8-Pin PDIP (P08)
ML2039IP	-40°C to 85°C	8-Pin PDIP (P08)

© Micro Linear 1998. Micro Linear is a registered trademark of Micro Linear Corporation. All other trademarks are the property of their respective owners.

Products described herein may be covered by one or more of the following U.S. patents: 4,897,611; 4,964,026; 5,027,116; 5,281,862; 5,283,483; 5,418,502; 5,508,570; 5,510,727; 5,523,940; 5,546,017; 5,559,470; 5,565,761; 5,592,128; 5,594,376; 5,652,479; 5,661,427; 5,663,874; 5,672,959; 5,689,167; 5,714,897; 5,717,798; 5,742,151; 5,747,977; 5,754,012; 5,757,174; 5,767,653; 5,777,514. Japan: 2,598,946; 2,619,299; 2,704,176. Other patents are pending.

Micro Linear reserves the right to make changes to any product herein to improve reliability, function or design. Micro Linear does not assume any liability arising out of the application or use of any product described herein, neither does it convey any license under its patent right nor the rights of others. The circuits contained in this data sheet are offered as possible applications only. Micro Linear makes no warranties or representations as to whether the illustrated circuits infringe any intellectual property rights of others, and will accept no responsibility or liability for use of any application herein. The customer is urged to consult with appropriate legal counsel before deciding on a particular application.

2092 Concourse Drive
San Jose, CA 95131
Tel: (408) 433-5200
Fax: (408) 432-0295
www.microlinear.com