

Rochester Electronics Manufactured Components

Rochester branded components are manufactured using either die/wafers purchased from the original suppliers or Rochester wafers recreated from the original IP. All recreations are done with the approval of the OCM.

Parts are tested using original factory test programs or Rochester developed test solutions to guarantee product meets or exceed the OCM data sheet.

Quality Overview

- ISO-9001
- AS9120 certification
- Qualified Manufacturers List (QML) MIL-PRF-35835
 - Class Q Military
 - Class V Space Level
- Qualified Suppliers List of Distributors (QSLD)
 - Rochester is a critical supplier to DLA and meets all industry and DLA standards.

Rochester Electronics, LLC is committed to supplying products that satisfy customer expectations for quality and are equal to those originally supplied by industry manufacturers.

The original manufacturer's datasheet accompanying this document reflects the performance and specifications of the Rochester manufactured version of this device. Rochester Electronics guarantees the performance of its semiconductor products to the original OEM specifications. 'Typical' values are for reference purposes only. Certain minimum or maximum ratings may be based on product characterization, design, simulation, or sample testing.



PAL16R8 Family

20-pin TTL Programmable Array Logic

DISTINCTIVE CHARACTERISTICS

- As fast as 7.5 ns maximum propagation delay
- Popular 20-pin architectures: 16L8, 16R8, 16R6, 16R4
- Programmable replacement for high-speed TTL logic
- Power-up reset for initialization on most devices
- Easy design with PALASM® software
- Programmable on standard PAL® device programmers
- 20-pin DIP and PLCC packages save space

GENERAL DESCRIPTION

The PAL16R8 Family (PAL16L8, PAL16R8, PAL16R6, PAL16R4) is AMD's standard 20-pin PAL device family. The devices provide user-programmable logic for replacing conventional SSI/MSI gates and flip-flops at a reduced chip count.

The family allows the systems engineer to implement the design on-chip, by opening fuse links to configure AND and OR gates within the device, according to the desired logic function. Complex interconnections between gates, which previously required time-consuming layout, are lifted from the PC board and placed on silicon, where they can be easily modified during prototyping or production.

The PAL device implements the familiar Boolean logic transfer function, the sum of products. The PAL device is a programmable AND array driving a fixed OR array. The AND array is programmed to create custom product terms, while the OR array sums selected terms at the outputs.

In addition, the PAL device provides the following options:

- Variable input/output pin ratio
- Programmable three-state outputs
- Registers with feedback

Product terms with all connections opened assume the logical HIGH state; product terms connected to both true and complement of any single input assume the logical LOW state. Registers consist of D-type flip-flops that are loaded on the LOW-to-HIGH transition of the clock. Unused input pins should be tied to V_{CC} or GND.

The entire PAL device family is supported by the PALASM software package. The PAL family is programmed on conventional PAL device programmers with appropriate personality and socket adapter modules. See the Programmer Reference Guide for approved programmers. Once the PAL device is programmed and verified an additional connection may be opened to prevent pattern readout. This feature secures proprietary circuits.

PRODUCT SELECTOR GUIDE

| DEVICE | DEDICATED INPUTS | OUTPUTS | PRODUCT TERMS/ OUTPUT | FEEDBACK | ENABLE |
|---------|------------------|--------------------|--------------------------|-------------|----------------|
| PAL16L8 | 10 | 6 comb. 2 comb. | 7 7 | I/O - | prog. prog. |
| PAL16R8 | 8 | 8 reg. | 8 | reg. | pin |
| PAL16R6 | 8 | 6 reg. 2 comb. | 8 7 | reg. I/O | pin prog. |
| PAL16R4 | 8 | 4 reg. 4 comb. | 8 7 | reg. I/O | pin prog. |

PERFORMANCE OPTIONS

| | | (Commercial) | | |
|---------------------------|-----|--------------|------|--------|
| Speed (t_{PD} , ns) | 35 | B-4 | A-2 | |
| | 25 | | B-2 | A |
| | 15 | | H-15 | B |
| | 10 | | | D |
| | 7.5 | | | -7 |
| | | | 55 | 80-100 |

Power (I_{CC} , mA)

Note:

For low power and high speed, the EE CMOS PALCE16V8 can directly replace the PAL16R8 Family.

OPERATING RANGES

| Commercial | Military |
|-------------|-------------|
| -7 | -12 |
| D (10 ns) | D (15 ns) |
| H-15 | |
| B (15 ns) | B (20 ns) |
| B-2 (25 ns) | B-2 (30 ns) |
| A (25 ns) | A (30 ns) |
| B-4 (35 ns) | B-4 (50 ns) |
| A-2 (35 ns) | A-2 (50 ns) |

BLOCK DIAGRAMS

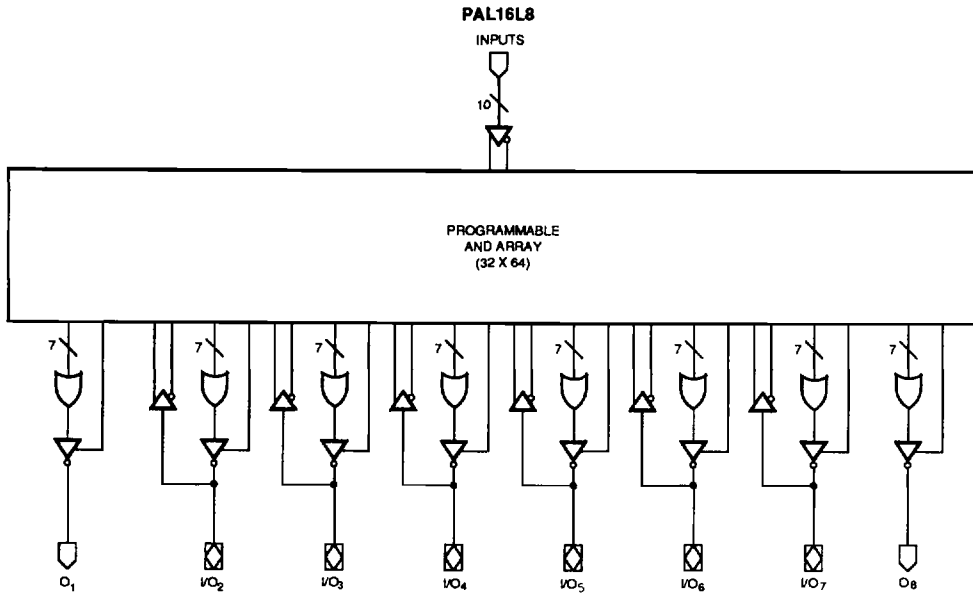

12468-004A

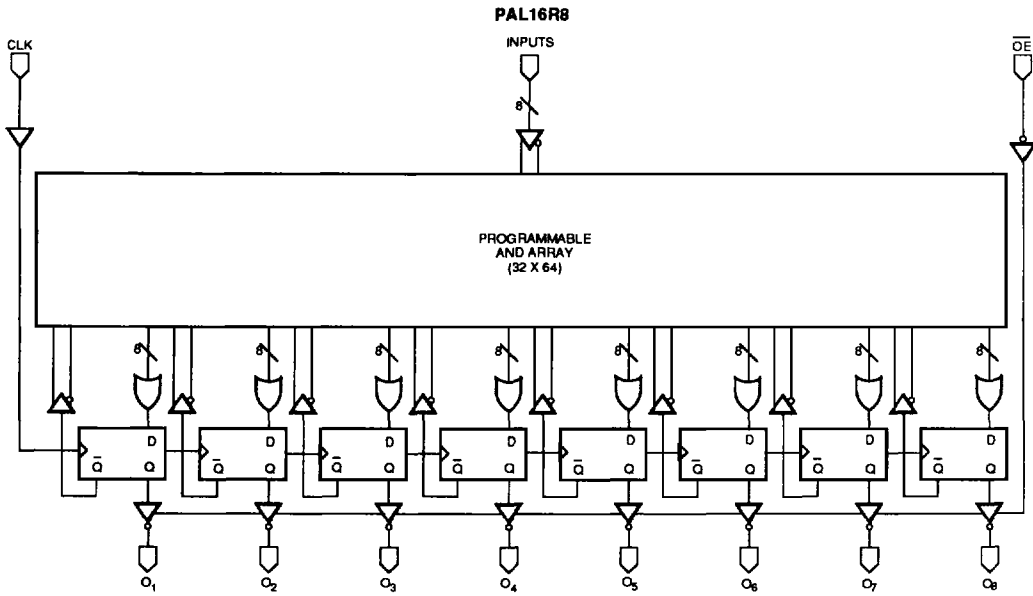

12468-001A

BLOCK DIAGRAMS

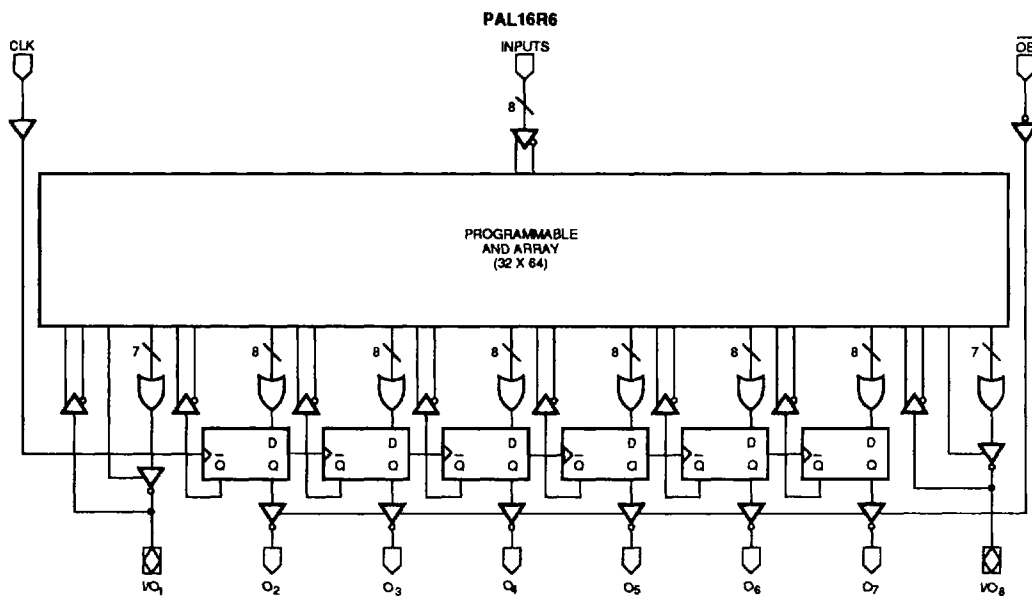

12468-002A

2

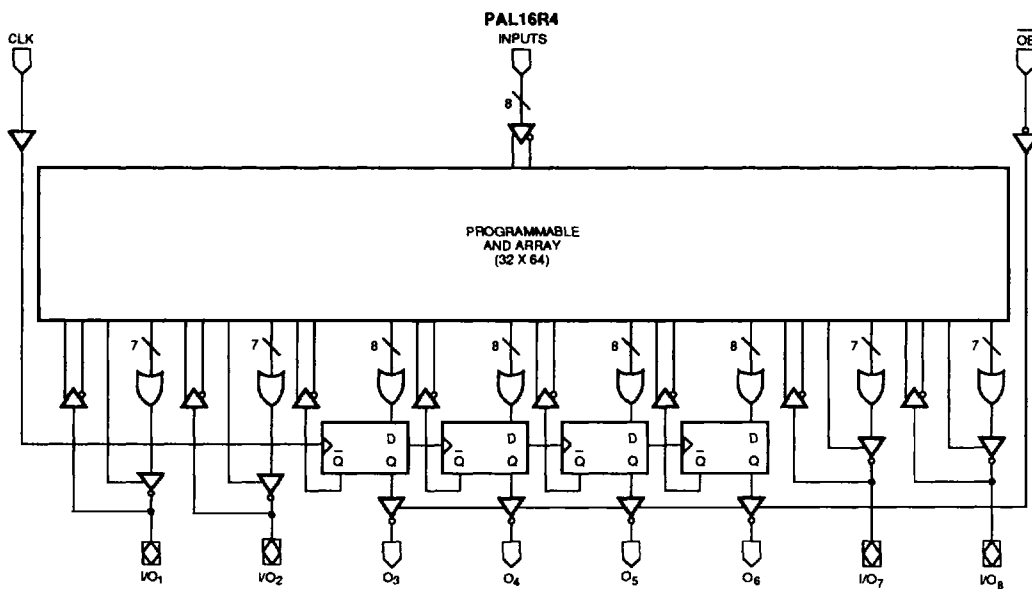

12468-003A

CONNECTION DIAGRAMS

Top View

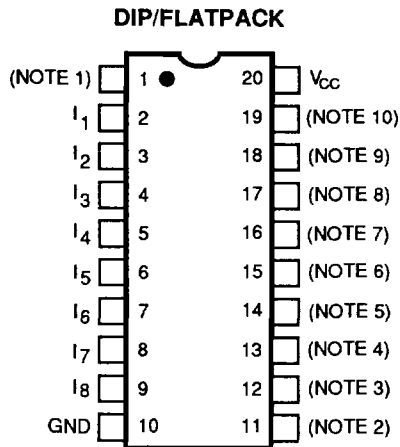

12468-005A

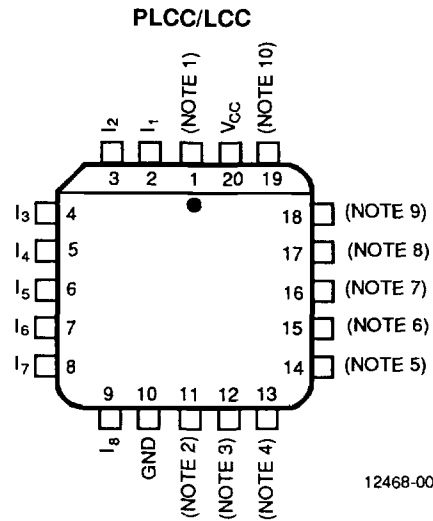

12468-006A

| Note | 16L8 | 16R8 | 16R6 | 16R4 |
|------|------------------|-----------------|------------------|------------------|
| 1 | I ₀ | CLK | CLK | CLK |
| 2 | I ₉ | \overline{OE} | \overline{OE} | \overline{OE} |
| 3 | O ₁ | O ₁ | I/O ₁ | I/O ₁ |
| 4 | I/O ₂ | O ₂ | O ₂ | I/O ₂ |
| 5 | I/O ₃ | O ₃ | O ₃ | O ₃ |
| 6 | I/O ₄ | O ₄ | O ₄ | O ₄ |
| 7 | I/O ₅ | O ₅ | O ₅ | O ₅ |
| 8 | I/O ₆ | O ₆ | O ₆ | O ₆ |
| 9 | I/O ₇ | O ₇ | O ₇ | I/O ₇ |
| 10 | O ₈ | O ₈ | I/O ₈ | I/O ₈ |

PIN DESIGNATIONS

CLK Clock
 GND Ground
 I Input
 I/O Input/Output
 O Output
 \overline{OE} Output Enable
 V_{CC} Supply Voltage

ORDERING INFORMATION

Commercial Products (AMD Marking Only)

AMD programmable logic products for commercial applications are available with several ordering options. The order number (Valid Combination) is formed by a combination of:

- a. Family Type
- b. Number of Array Inputs
- c. Output Type
- d. Number of Outputs
- e. Power
- f. Speed
- g. Package Type
- h. Operating Conditions
- i. Optional Processing

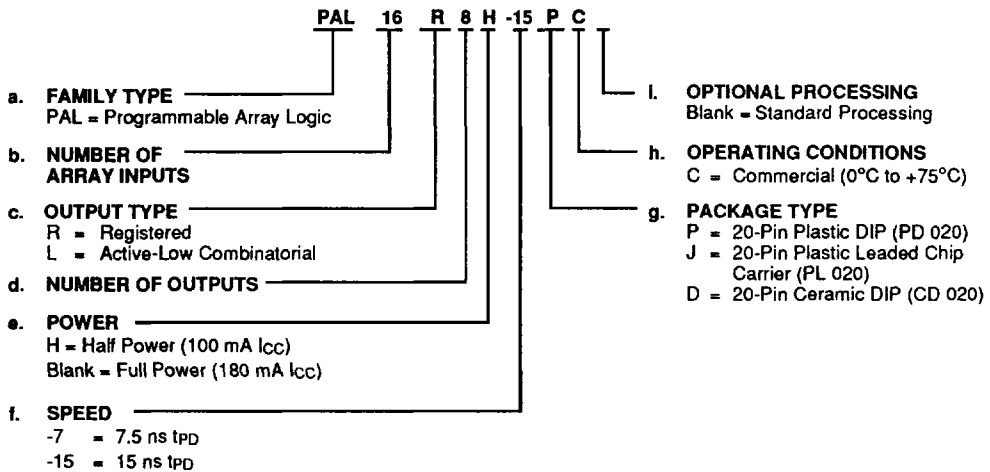

2

| Valid Combinations | | |
|--------------------|----------|------------|
| PAL16L8 | -7, H-15 | PC, JC, DC |
| PAL16R8 | | |
| PAL16R6 | | |
| PAL16R4 | | |

Valid Combinations

The Valid Combinations table lists configurations planned to be supported in volume for this device. Consult the local AMD sales office to confirm availability of specific valid combinations, and to check on newly released combinations.

Note: Marked with AMD logo.

ORDERING INFORMATION

Commercial Products (MMI Marking Only)

AMD programmable logic products for commercial applications are available with several ordering options. The order number (Valid Combination) is formed by a combination of:

- a. Family Type
- b. Number of Array Inputs
- c. Output Type
- d. Number of Outputs
- e. Speed
- f. Power
- g. Operating Conditions
- h. Package Type
- i. Optional Processing

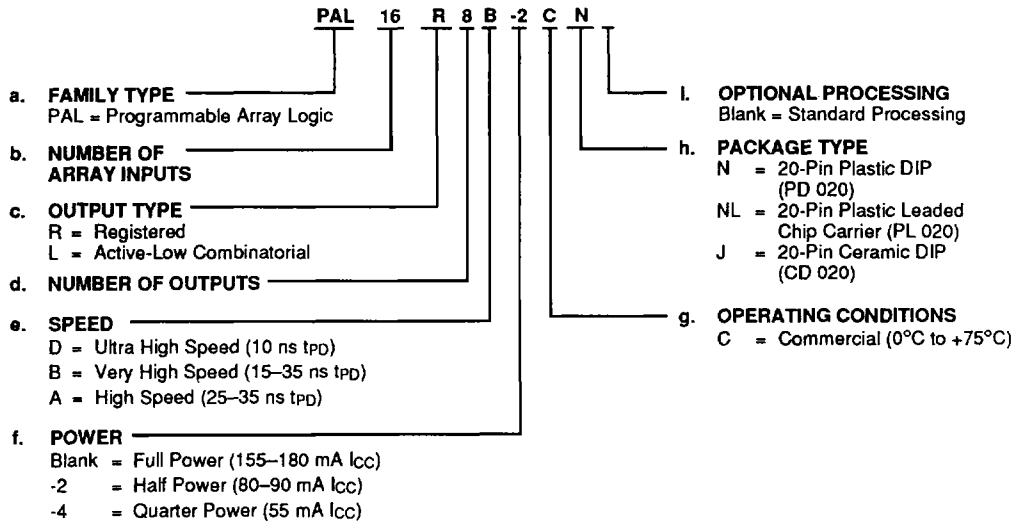

| Valid Combinations | | |
|--------------------|----------|-------------|
| PAL16L8 | D, B | CN, CNL, CJ |
| PAL16R8 | B-2, A | |
| PAL16R6 | B-4, A-2 | |
| PAL16R4 | | |

Valid Combinations

The Valid Combinations table lists configurations planned to be supported in volume for this device. Consult the local AMD sales office to confirm availability of specific valid combinations, and to check on newly released combinations.

Note: Marked with MMI logo.

ORDERING INFORMATION

APL Products (AMD Marking Only)

AMD programmable logic products for Aerospace and Defense applications are available with several ordering options. APL (Approved Products List) products are fully compliant with MIL-STD-883 requirements. The order number (Valid Combination) is formed by a combination of:

- a. Family Type
- b. Number of Array Inputs
- c. Output Type
- d. Number of Outputs
- e. Speed
- f. Device Class
- g. Package Type
- h. Lead Finish

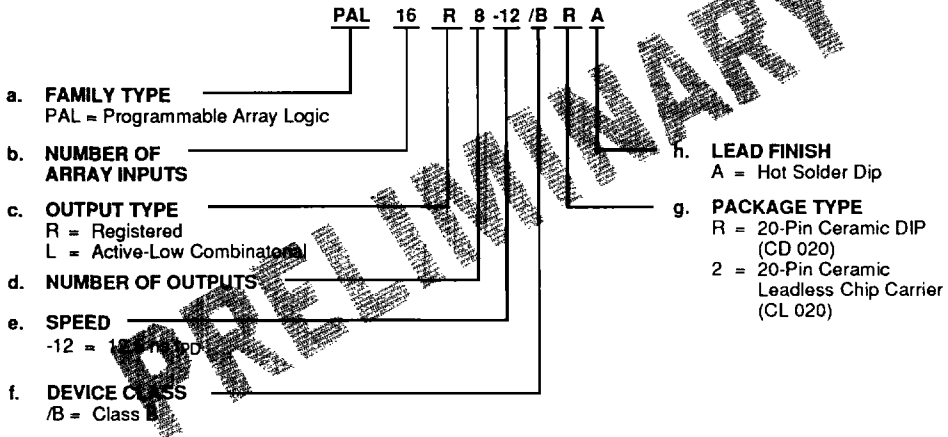

PRELIMINARY

2

| Valid Combinations | | |
|--------------------|-----|------------|
| PAL16L8 | -12 | /BRA, /B2A |
| PAL16R8 | | |
| PAL16R6 | | |
| PAL16R4 | | |

Valid Combinations

The Valid Combinations table lists configurations planned to be supported in volume for this device. Consult the local AMD sales office to confirm availability of specific valid combinations, to check on newly released combinations, and to obtain additional data on AMD's standard military grade products.

Note: Marked with AMD logo.

Group A Tests

Group A Tests consist of Subgroups: 1, 2, 3, 7, 8, 9, 10, 11.

Military Burn-In

Military burn-in is in accordance with the current revision of MIL-STD-883, Test Methods 1015, Conditions A through E. Test conditions are selected at AMD's option.

ORDERING INFORMATION

APL Products (MMI Marking Only)

AMD programmable logic products for Aerospace and Defense applications are available with several ordering options. APL (Approved Products List) products are fully compliant with MIL-STD-883 requirements. The order number (Valid Combination) is formed by a combination of:

- a. Family Type
- b. Number of Array Inputs
- c. Output Type
- d. Number of Outputs
- e. Speed
- f. Power
- g. Operating Conditions
- h. Package Type
- i. Optional Processing

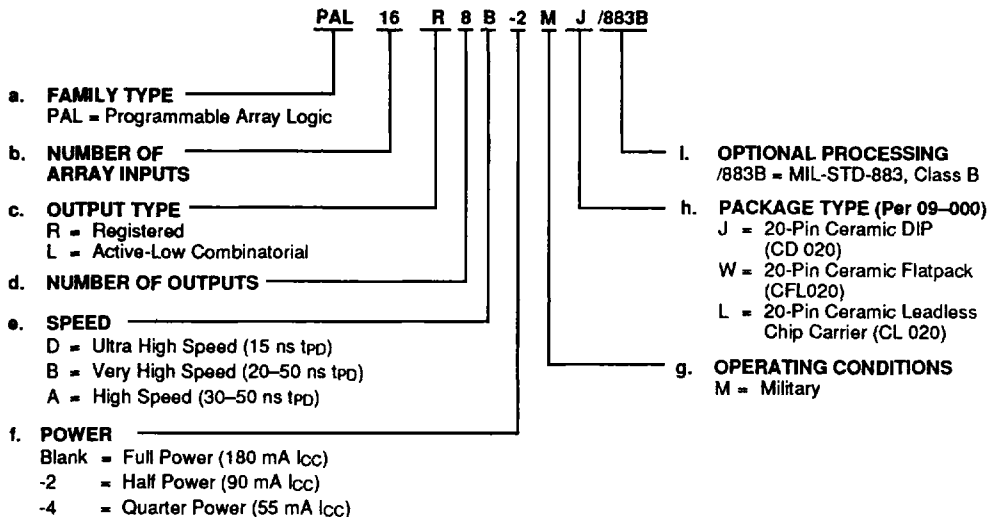

| Valid Combinations | | |
|--------------------|----------|----------|
| PAL16L8 | D, B, | MJ/883B, |
| PAL16R8 | B-2, A, | MW/883B, |
| PAL16R6 | B-4, A-2 | ML/883B |
| PAL16R4 | | |

Valid Combinations

The Valid Combinations table lists configurations planned to be supported in volume for this device. Consult the local AMD sales office to confirm availability of specific valid combinations, to check on newly released combinations, and to obtain additional information on AMD's Standard Military grade products.

Note: Marked with MMI logo.

Group A Tests

Group A Tests consist of Subgroups: 1, 2, 3, 7, 8, 9, 10, 11.

Military Burn-In

Military burn-in is in accordance with the current revision of MIL-STD-883, Test Methods 1015, Conditions A through E. Test conditions are selected at AMD's option.

FUNCTIONAL DESCRIPTION

Standard 20-pin PAL Family

The standard bipolar 20-pin PAL family devices have common electrical characteristics and programming procedures. Four different devices are available, including both registered and combinatorial devices. All parts are produced with a fuse link at each input to the AND gate array, and connections may be selectively removed by applying appropriate voltages to the circuit. Utilizing an easily-implemented programming algorithm, these products can be rapidly programmed to any customized pattern. Information on approved programmers can be found in the Programmer Reference Guide. Extra test words are pre-programmed during manufacturing to ensure extremely high field programming yields, and provide extra test paths to achieve excellent parametric correlation.

Variable Input/Output Pin Ratio

The registered devices have eight dedicated input lines, and each combinatorial output is an I/O pin. The PAL16L8 has ten dedicated input lines and six of the eight combinatorial outputs are I/O pins. Buffers for device inputs have complementary outputs to provide user-programmable input signal polarity. Unused input pins should be tied to V_{CC} or GND.

Programmable Three-State Outputs

Each output has a three-state output buffer with three-state control. On combinatorial outputs, a product term controls the buffer, allowing enable and disable to be a function of any product of device inputs or output feedback. The combinatorial output provides a bidirectional I/O pin and may be configured as a dedicated input if the output buffer is always disabled. On registered outputs, an input pin controls the enabling of the three-state outputs.

Registers with Feedback

Registered outputs are provided for data storage and synchronization. Registers are composed of D-type flip-flops that are loaded on the LOW-to-HIGH transition of the clock input.

Power-Up Reset

Applies to -7 (-12 Mil), H-15, B, B-2, A, A-2 Series Only

All flip-flops power-up to a logic LOW for predictable system initialization. Outputs of the listed Series will be

HIGH due to the active-low outputs. The V_{CC} rise must be monotonic and the reset delay time is 1000 ns maximum.

Register Preload

Applies to -7 (-12 Mil), H-15 Series Only

The register on the listed Series can be preloaded from the output pins to facilitate functional testing of complex state machine designs. This feature allows direct loading of arbitrary states, making it unnecessary to cycle through long test vector sequences to reach a desired state. In addition, transitions from illegal states can be verified by loading illegal states and observing proper recovery.

Security Fuse

After programming and verification, a PAL16R8 Family design can be secured by programming the security fuse. Once programmed, this fuse defeats readback of the internal programmed pattern by a device programmer, securing proprietary designs from competitors. When the security fuse is programmed, the array will read as if every fuse is intact. Exceptions are the -7 (-12 Mil) Series, where the array will read as if every fuse is programmed.

Quality and Testability

The PAL16R8 Family offers a very high level of built-in quality. Extra programmable fuses provide a means of verifying performance of all AC and DC parameters. In addition, this verifies complete programmability and functionality of the device to provide the highest programming yields and post-programming functional yields in the industry.

Technology

The high-speed -7 (-12 Mil), D, and H-15 Series are fabricated with AMD's advanced oxide-isolated bipolar process. This process reduces parasitic capacitances and minimum geometries to provide higher performance. The array connections are formed with proven PtSi fuses for the -7 Series and TiW fuses for the D and H-15 Series. The remaining Series are fabricated with AMD's junction-isolated process, utilizing TiW fuses.

LOGIC DIAGRAM

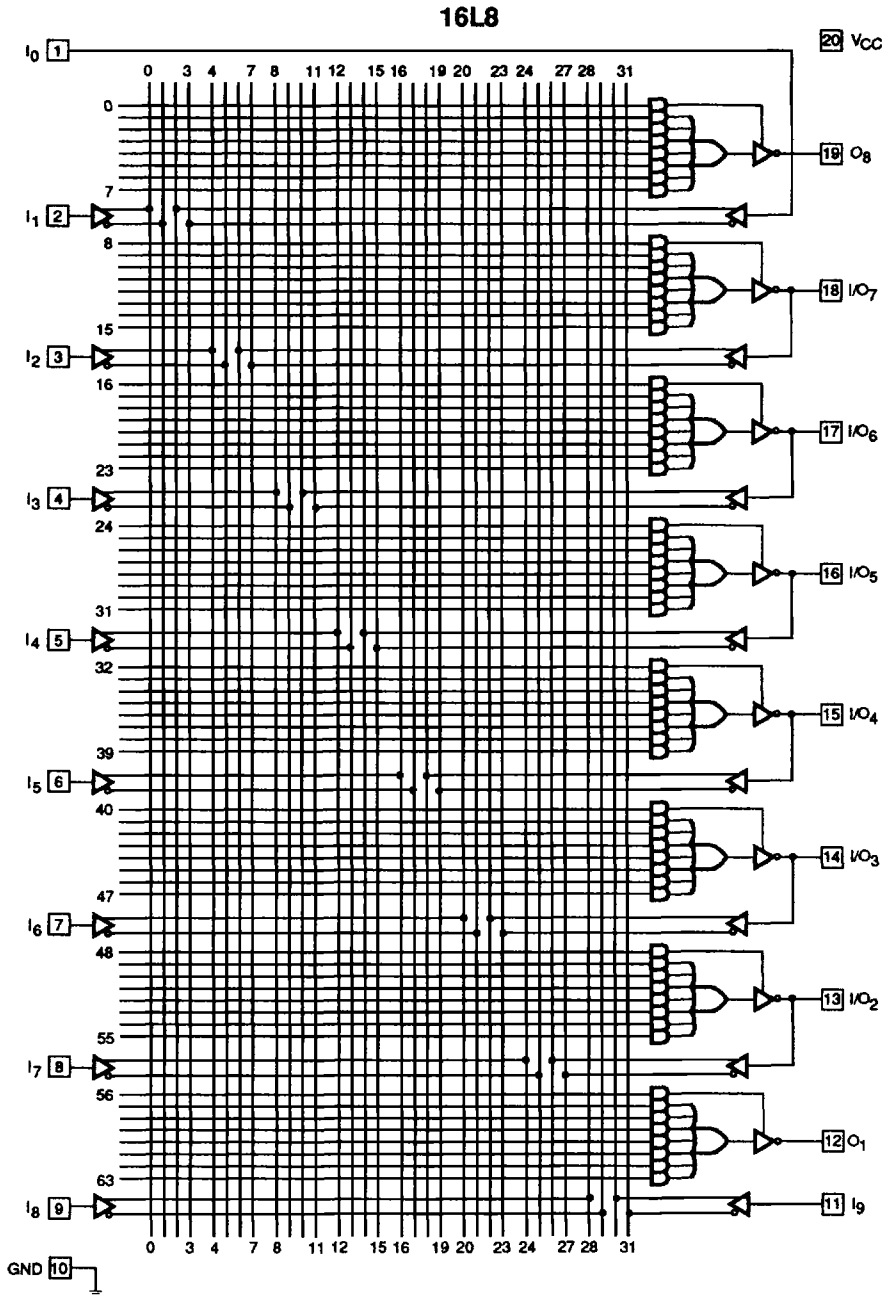

12468-012A

LOGIC DIAGRAM

16R8

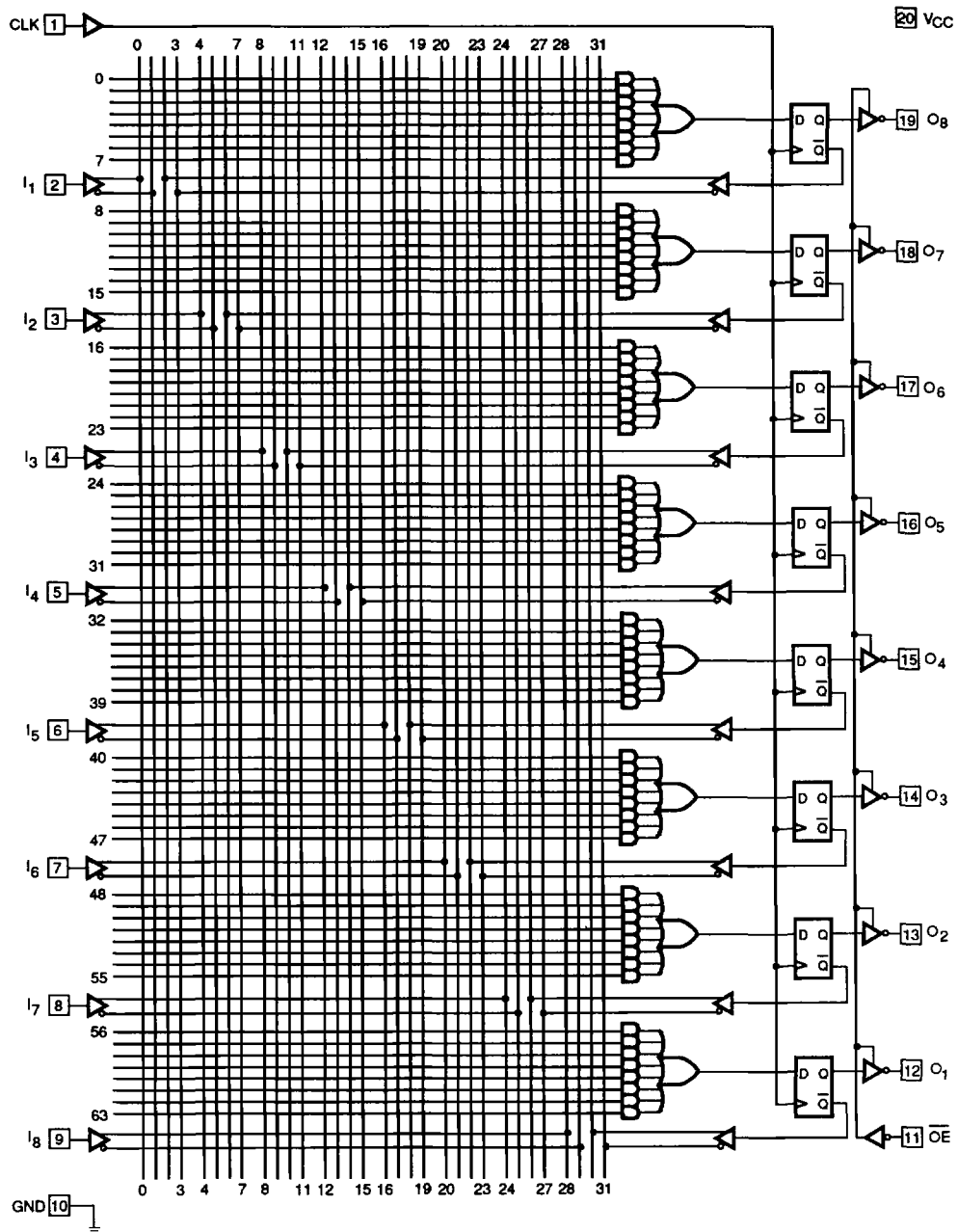

2

12468-013A

LOGIC DIAGRAM

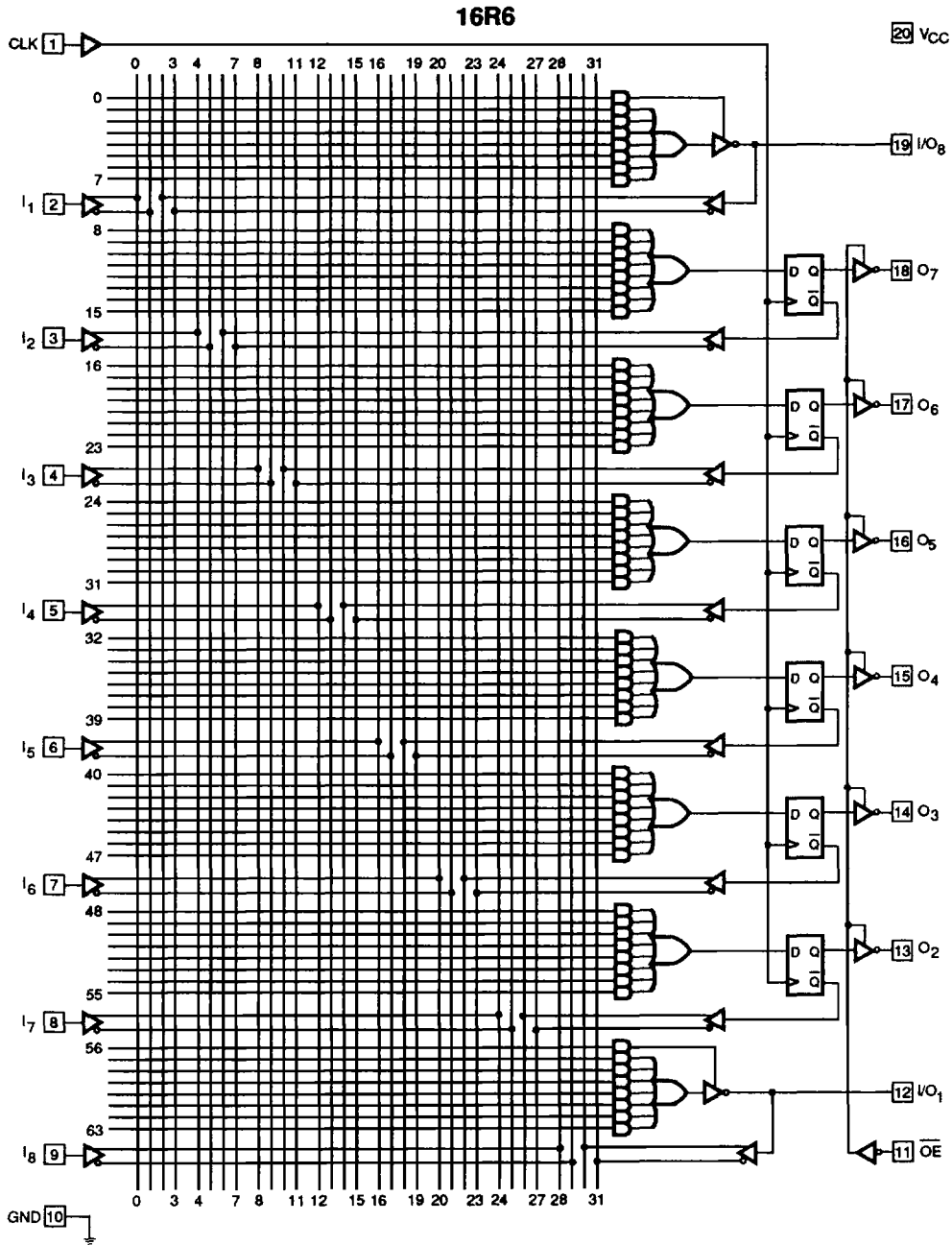

12468-014A

LOGIC DIAGRAM

16R4

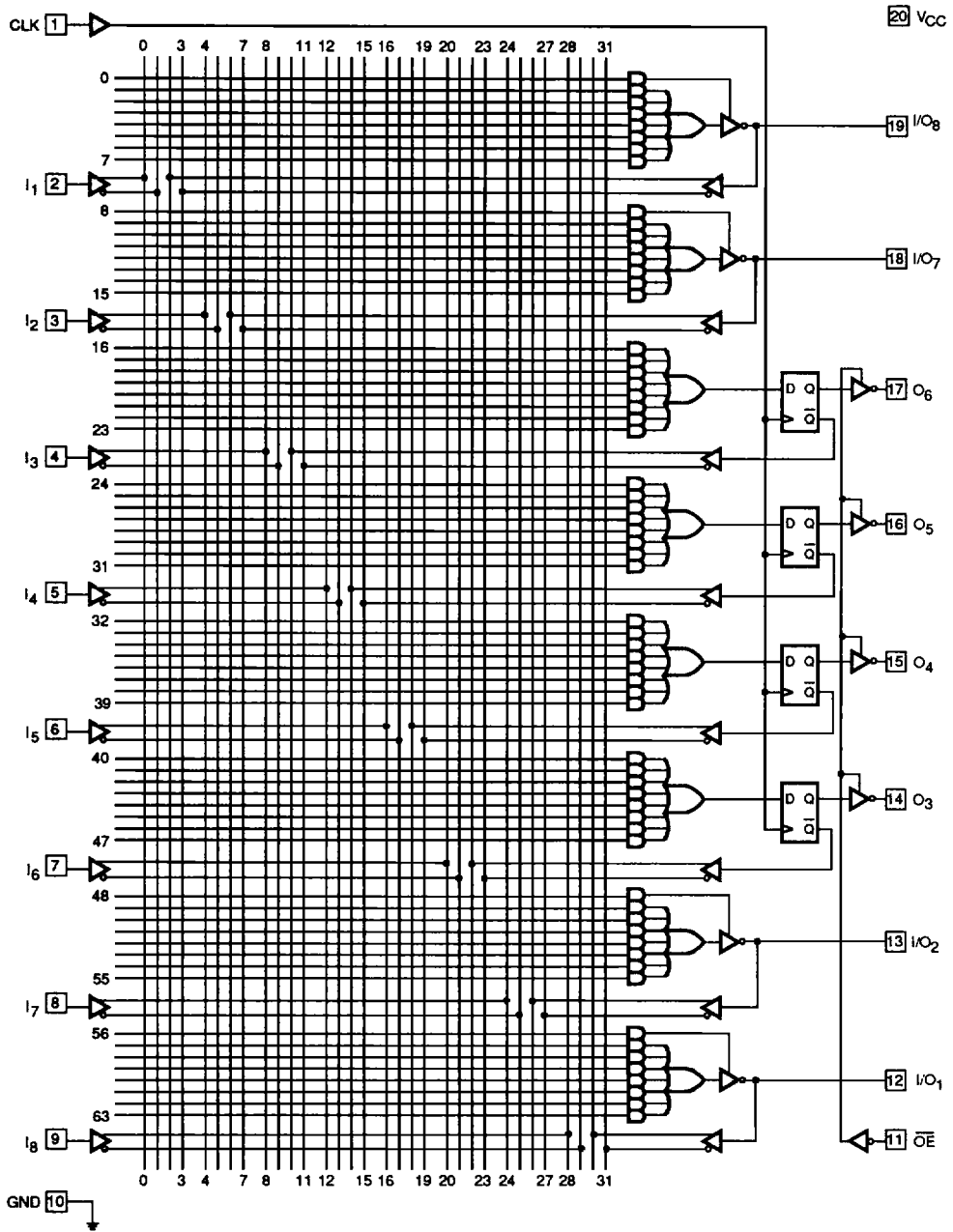

2

12468-015A

ABSOLUTE MAXIMUM RATINGS

| | |
|--|----------------------------|
| Storage Temperature | -65°C to +150°C |
| Ambient Temperature with Power Applied | -55°C to +125°C |
| Supply Voltage with Respect to Ground | -0.5 V to +7.0 V |
| DC Input Voltage | -1.2 V to +7.0 V |
| DC Input Current | -30 mA to +5 mA |
| DC Output or I/O Pin Voltage | -0.5 V to $V_{CC} + 0.5$ V |
| Static Discharge Voltage | 2001 V |

Stresses above those listed under Absolute Maximum Ratings may cause permanent device failure. Functionality at or above these limits is not implied. Exposure to Absolute Maximum Ratings for extended periods may affect device reliability. Programming conditions may differ.

OPERATING RANGES

Commercial (C) Devices

| | |
|--|--------------------|
| Ambient Temperature (T_A) | 0°C to +75°C |
| Operating in Free Air | 0°C to +75°C |
| Supply Voltage (V_{CC}) with Respect to Ground | +4.75 V to +5.25 V |

Operating ranges define those limits between which the functionality of the device is guaranteed.

DC CHARACTERISTICS over COMMERCIAL operating ranges unless otherwise specified

| Parameter Symbol | Parameter Description | Test Conditions | Min. | Max. | Unit |
|------------------|---------------------------------------|---|------|------|---------|
| V_{OH} | Output HIGH Voltage | $I_{OH} = -3.2$ mA $V_{IN} = V_{IH}$ or V_{IL} $V_{CC} = \text{Min.}$ | 2.4 | | V |
| V_{OL} | Output LOW Voltage | $I_{OL} = 24$ mA $V_{IN} = V_{IH}$ or V_{IL} $V_{CC} = \text{Min.}$ | | 0.5 | V |
| V_{IH} | Input HIGH Voltage | Guaranteed Input Logical HIGH Voltage for all Inputs (Note 1) | 2.0 | | V |
| V_{IL} | Input LOW Voltage | Guaranteed Input Logical LOW Voltage for all Inputs (Note 1) | | 0.8 | V |
| V_I | Input Clamp Voltage | $I_{IN} = -18$ mA, $V_{CC} = \text{Min.}$ | | -1.2 | V |
| I_{IH} | Input HIGH Current | $V_{IN} = 2.7$ V, $V_{CC} = \text{Max.}$ (Note 2) | | 25 | μ A |
| I_{IL} | Input LOW Current | $V_{IN} = 0.4$ V, $V_{CC} = \text{Max.}$ (Note 2) | | -250 | μ A |
| I_I | Maximum Input Current | $V_{IN} = 5.5$ V, $V_{CC} = \text{Max.}$ | | 1 | mA |
| I_{OZH} | Off-State Output Leakage Current HIGH | $V_{OUT} = 2.7$ V, $V_{CC} = \text{Max.}$ $V_{IN} = V_{IH}$ or V_{IL} (Note 2) | | 100 | μ A |
| I_{OZL} | Off-State Output Leakage Current LOW | $V_{OUT} = 0.4$ V, $V_{CC} = \text{Max.}$ $V_{IN} = V_{IH}$ or V_{IL} (Note 2) | | -100 | μ A |
| I_{SC} | Output Short-Circuit Current | $V_{OUT} = 0.5$ V, $V_{CC} = \text{Max.}$ (Note 3) | -30 | -130 | mA |
| I_{CC} | Supply Current | $V_{IN} = 0$ V, Outputs Open ($I_{OUT} = 0$ mA) $V_{CC} = \text{Max.}$ | | 180 | mA |

Notes:

1. These are absolute values with respect to device ground and all overshoots due to system and/or tester noise are included.
2. I/O pin leakage is the worst case of I_{IL} and I_{OZL} (or I_{IH} and I_{OZH}).
3. Not more than one output should be tested at a time. Duration of the short-circuit should not exceed one second. $V_{OUT} = 0.5$ V has been chosen to avoid test problems caused by tester ground degradation.

CAPACITANCE (Note 1)

| Parameter Symbol | Parameter Description | Test Conditions | | Typ. | Unit |
|------------------|-----------------------|--------------------------|---|------|------|
| C _{IN} | Input Capacitance | V _{IN} = 2.0 V | V _{CC} = 5.0 V T _A = 25°C f = 1 MHz | 5 | pF |
| C _{OUT} | Output Capacitance | V _{OUT} = 2.0 V | | 8 | |

Note:

1. These parameters are not 100% tested, but are evaluated at initial characterization and at any time the design is modified where capacitance may be affected.

SWITCHING CHARACTERISTICS over COMMERCIAL operating ranges (Note 2)

| Parameter Symbol | Parameter Description | | | Min. (Note 3) | Max. | Unit | |
|-------------------|--|--------------------|--------------------|--|------|------|-----|
| t _{PD} | Input or Feedback to Combinatorial Output | | 16L8, 16R6 16R4 | 3 | 7.5 | ns | |
| | | 1 Output Switching | | 3 | 7 | | |
| t _s | Setup Time from Input or Feedback to Clock | | 16R8, 16R6 16R4 | 7 | | ns | |
| t _H | Hold Time | | | 0 | | ns | |
| t _{CO} | Clock to Output | | | 3 | 6.5 | ns | |
| t _{CF} | Clock to Feedback (Note 4) | | | | 3 | ns | |
| t _{SKEW} | Skew Between Registered Outputs (Note 5) | | | | 1 | ns | |
| t _{WL} | Clock Width | LOW | | 16R4 | 5 | | ns |
| | | HIGH | | | 5 | | ns |
| f _{MAX} | Maximum Frequency (Note 6) | External Feedback | | 1/(t _s + t _{CO}) | 74 | | MHz |
| | | Internal Feedback | | 1/(t _s + t _{CF}) | 100 | | MHz |
| | | No Feedback | | 1/(t _{WH} + t _{WL}) | 100 | | MHz |
| t _{PZX} | \overline{OE} to Output Enable | | | 3 | 8 | ns | |
| t _{PXZ} | \overline{OE} to Output Disable | | | 3 | 8 | ns | |
| t _{EA} | Input to Output Enable Using Product Term Control | | 16L8, 16R6 | 3 | 10 | ns | |
| t _{ER} | Input to Output Disable Using Product Term Control | | 16R4 | 3 | 10 | ns | |

Notes:

2. See Switching Test Circuit for test conditions.
3. Output delay minimums are measured under best-case conditions.
4. Calculated from measured f_{MAX} internal.
5. Skew is measured with all outputs switching in the same direction.
6. These parameters are not 100% tested, but are calculated at initial characterization and at any time the design is modified where the frequency may be affected.

2

ABSOLUTE MAXIMUM RATINGS

| | |
|--|----------------------------|
| Storage Temperature | -65°C to +150°C |
| Ambient Temperature with Power Applied | -55°C to +125°C |
| Supply Voltage with Respect to Ground | -0.5 V to +7.0 V |
| DC Input Voltage | -0.5 V to +5.5 V |
| DC Input Current | -30 mA to +5 mA |
| DC Output or I/O Pin Voltage | -0.5 V to $V_{CC} + 0.5$ V |

Stresses above those listed under Absolute Maximum Ratings may cause permanent device failure. Functionality at or above these limits is not implied. Exposure to Absolute Maximum Ratings for extended periods may affect device reliability. Programming conditions may differ. Absolute Maximum Ratings are for system design reference; parameters given are not tested.

OPERATING RANGES

Military (M) Devices (Note 1)

| | |
|--|--------------------|
| Ambient Temperature (T_A) | -55°C Min. |
| Operating in Free Air Temperature | 125°C Max. |
| Supply Voltage (V_{CC}) with Respect to Ground | +4.50 V to +5.50 V |

Operating ranges define those limits between which the functionality of the device is guaranteed.

Note:

1. Military products are tested at $T_A = +25^\circ\text{C}$, $+125^\circ\text{C}$, and -55°C , per MIL-STD-883.

DC CHARACTERISTICS over MILITARY operating ranges unless otherwise specified (Note 2)

| Parameter Symbol | Parameter Description | Test Conditions | Min. | Max. | Unit |
|------------------|---------------------------------------|--|------|------|---------------|
| V_{OH} | Output HIGH Voltage | $I_{OH} = -12$ mA, $V_{IN} = V_{IH}$ or V_{IL} , $V_{CC} = \text{Min.}$ | 2.4 | | V |
| V_{OL} | Output LOW Voltage | $I_{OL} = 12$ mA, $V_{IN} = V_{IH}$ or V_{IL} , $V_{CC} = \text{Min.}$ | | 0.5 | V |
| V_{IH} | Input HIGH Voltage | Guaranteed Input Logical HIGH Voltage for all Inputs (Note 3) | 2.0 | | V |
| V_{IL} | Input LOW Voltage | Guaranteed Input Logical LOW Voltage for all Inputs (Note 3) | | 0.8 | V |
| V_I | Input Clamp Voltage | $I_{IN} = -18$ mA, $V_{CC} = \text{Min.}$ | | -1.2 | V |
| I_{IH} | Input HIGH Current | $V_{IN} = 2.7$ V, $V_{CC} = \text{Max.}$ (Note 4) | | 25 | μA |
| I_{IL} | Input LOW Current | $V_{IN} = 0.4$ V, $V_{CC} = \text{Max.}$ (Note 4) | | -250 | μA |
| I_I | Maximum Input Current | $V_{IN} = 5.5$ V, $V_{CC} = \text{Max.}$ | | 1 | mA |
| I_{OZH} | Off-State Output Leakage Current HIGH | $V_{OUT} = 2.7$ V, $V_{CC} = \text{Max.}$, $V_{IN} = V_{IH}$ or V_{IL} (Note 4) | | 100 | μA |
| I_{OZL} | Off-State Output Leakage Current LOW | $V_{OUT} = 0.4$ V, $V_{CC} = \text{Max.}$, $V_{IN} = V_{IH}$ or V_{IL} (Note 4) | | -100 | μA |
| I_{SC} | Output Short-Circuit Current | $V_{OUT} = 0.5$ V, $V_{CC} = \text{Max.}$ (Note 5) | -30 | -130 | mA |
| I_{CC} | Supply Current | $V_{IN} = 0$ V, Outputs Open ($I_{OUT} = 0$ mA), $V_{CC} = \text{Max.}$ | | 180 | mA |

Notes:

2. For APL Products, Group A, Subgroups 1, 2, and 3 are tested per MIL-STD-883, Method 5005, unless otherwise noted.
3. V_{IL} and V_{IH} are input conditions of output tests and are not themselves directly tested. V_{IL} and V_{IH} are absolute voltages with respect to device ground and include all overshoots due to system and/or tester noise. Do not attempt to test these values without suitable equipment.
4. I/O pin leakage is the worst case of I_{IL} and I_{OZL} (or I_{IH} and I_{OZH}).
5. Not more than one output should be tested at a time. Duration of the short-circuit should not exceed one second. $V_{OUT} = 0.5$ V has been chosen to avoid test problems caused by tester ground degradation.

CAPACITANCE (Note 1)

| Parameter Symbol | Parameter Description | Test Conditions | | Typ. | Unit |
|------------------|-----------------------|--------------------------|---|------|------|
| C _{IN} | Input Capacitance | V _{IN} = 2.0 V | V _{CC} = 5.0 V T _A = 25°C f = 1 MHz | 5 | pF |
| C _{OUT} | Output Capacitance | V _{OUT} = 2.0 V | | 8 | |

Note:

- These parameters are not 100% tested, but are evaluated at initial characterization and at any time the design is modified where capacitance may be affected.

SWITCHING CHARACTERISTICS over MILITARY operating ranges (Note 2)

| Parameter Symbol | Parameter Description | | Min. (Typ.) | Max. | Unit | |
|-------------------|---|--------------------|--------------------|------|------|-----|
| t _{PD} | Input or Feedback to Combinatorial Output | 1 Output Switching | 16L8, 16R4 | 3 | 12.5 | ns |
| | | | 16R6 | 3 | 12 | |
| t _S | Setup Time from Input or Feedback to Clock | | | 2 | ns | |
| t _H | Hold Time | | | 0 | ns | |
| t _{CO} | Clock to Output | | | 3 | 11 | ns |
| t _{CF} | Clock to Feedback (Note 4) | | | | 6.5 | ns |
| t _{SKEW} | Skew Between Registered Outputs (Note 5) | | | | 1 | ns |
| t _{WL} | Clock Width | L _{OW} | 16R8, 16R6 16R4 | 10 | | ns |
| t _{WH} | | H _{IGH} | | 8 | | ns |
| f _{MAX} | Maximum Frequency (Note 6) | External Feedback | | 43.4 | | MHz |
| | | Internal Feedback | | 54 | | MHz |
| | | No Feedback | | 55.5 | | MHz |
| t _{PZX} | OE to Input Enable (Note 7) | | | 3 | 10 | ns |
| t _{PXZ} | OE to Output Disable (Note 7) | | | 3 | 10 | ns |
| t _{EA} | Input to Output Enable Using Product Term Control (Note 7) | | 16L8, 16R6 16R4 | 3 | 15 | ns |
| t _{ER} | Input to Output Disable Using Product Term Control (Note 7) | | | 3 | 12 | ns |

Notes:

- See Switching Test Circuit for test conditions. For APL products Group A, Subgroups 9, 10, and 11 are tested per MIL-STD-883, Method 5005, unless otherwise noted.
- Minimum value for t_{PD}, t_{CO}, t_{PZX}, t_{PXZ}, t_{EA}, and t_{ER} parameters should be used for simulation purposes only and are not tested.
- Calculated from measured f_{MAX} internal.
- Skew is measured with all outputs switching in the same direction.
- These parameters are not 100% tested, but are calculated at initial characterization and at any time the design is modified where frequency may be affected.
- These parameters are not 100% tested, but are evaluated at initial characterization and at any time the design is modified where these parameters may be affected.

MEASURED SWITCHING CHARACTERISTICS

$V_{CC} = 4.75\text{ V}$, $T_A = 75^\circ\text{C}$ (Note 1)

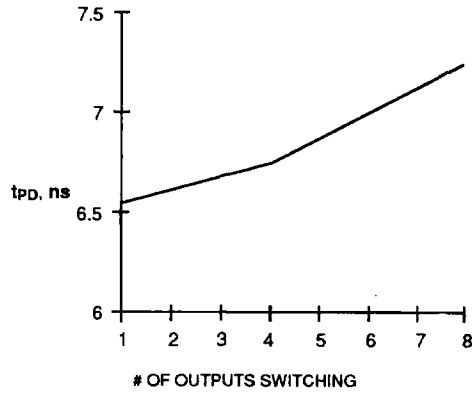

t_{PD} vs. Number of Outputs Switching

10240-001A

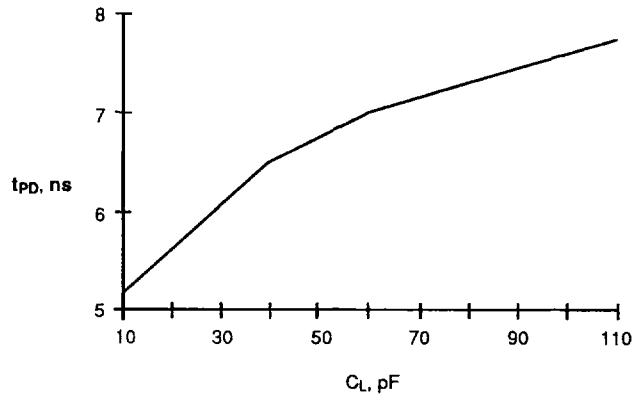

t_{PD} vs. Load Capacitance

10240-002A

Note:

1. These parameters are not 100% tested, but are evaluated at initial characterization and at any time the design is modified where t_{PD} may be affected.

CURRENT VS. VOLTAGE (I-V) CHARACTERISTICS

$V_{CC} = 5.0 \text{ V}$, $T_A = 25^\circ\text{C}$

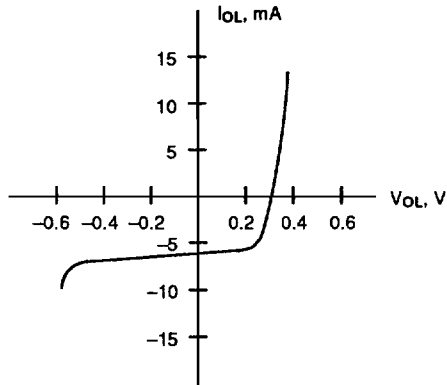

Output, LOW

10240-003A

2

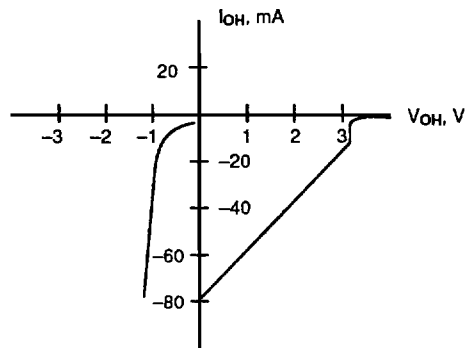

Output, HIGH

10240-004A

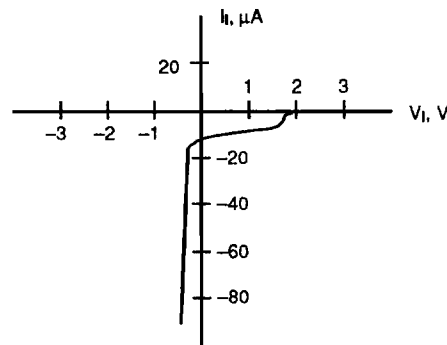

Input

10240-005A

ABSOLUTE MAXIMUM RATINGS

| | |
|--|------------------|
| Storage Temperature | -65°C to +150°C |
| Ambient Temperature with Power Applied | -55°C to +125°C |
| Supply Voltage with Respect to Ground | -0.5 V to +7.0 V |
| DC Input Voltage | -1.5 V to +5.5 V |
| DC Output or I/O Pin Voltage | -0.5 V to +5.5 V |
| Static Discharge Voltage | 2001 V |

OPERATING RANGES**Commercial (C) Devices**

| | |
|--|--------------------|
| Ambient Temperature (T _A) | 0°C to +75°C |
| Operating in Free Air | 0°C to +75°C |
| Supply Voltage (V _{CC}) with Respect to Ground | +4.75 V to +5.25 V |

Operating ranges define those limits between which the functionality of the device is guaranteed.

Stresses above those listed under Absolute Maximum Ratings may cause permanent device failure. Functionality at or above these limits is not implied. Exposure to Absolute Maximum Ratings for extended periods may affect device reliability. Programming conditions may differ.

DC CHARACTERISTICS over COMMERCIAL operating ranges unless otherwise specified

| Parameter Symbol | Parameter Description | Test Conditions | Min. | Max. | Unit |
|------------------|---------------------------------------|---|------|------|------|
| V _{OH} | Output HIGH Voltage | I _{OH} = -3.2 mA V _{IN} = V _{IH} or V _{IL} V _{CC} = Min. | 2.4 | | V |
| V _{OL} | Output LOW Voltage | I _{OL} = 24 mA V _{IN} = V _{IH} or V _{IL} V _{CC} = Min. | | 0.5 | V |
| V _{IH} | Input HIGH Voltage | Guaranteed Input Logical HIGH Voltage for all inputs (Note 1) | 2.0 | | V |
| V _{IL} | Input LOW Voltage | Guaranteed Input Logical LOW Voltage for all inputs (Note 1) | | 0.8 | V |
| V _I | Input Clamp Voltage | I _{IN} = -18 mA, V _{CC} = Min. | | -1.5 | V |
| I _{IH} | Input HIGH Current | V _{IN} = 2.4 V, V _{CC} = Max. (Note 2) | | 25 | μA |
| I _{IL} | Input LOW Current | V _{IN} = 0.4 V, V _{CC} = Max. (Note 2) | | -250 | μA |
| I _I | Maximum Input Current | V _{IN} = 5.5 V, V _{CC} = Max. | | 100 | μA |
| I _{OZH} | Off-State Output Leakage Current HIGH | V _{OUT} = 2.4 V, V _{CC} = Max. V _{IN} = V _{IH} or V _{IL} (Note 2) | | 100 | μA |
| I _{OZL} | Off-State Output Leakage Current LOW | V _{OUT} = 0.4 V, V _{CC} = Max. V _{IN} = V _{IH} or V _{IL} (Note 2) | | -100 | μA |
| I _{sc} | Output Short-Circuit Current | V _{OUT} = 0.5 V, V _{CC} = Max. (Note 3) | -30 | -130 | mA |
| I _{CC} | Supply Current | V _{IN} = 0 V, Outputs Open (I _{OUT} = 0 mA) V _{CC} = Max. | | 180 | mA |

Notes:

1. These are absolute values with respect to device ground and all overshoots due to system and/or tester noise are included.
2. I/O pin leakage is the worst case of I_{IL} and I_{OZL} (or I_{IH} and I_{OZH}).
3. Not more than one output should be tested at a time. Duration of the short-circuit should not exceed one second. V_{OUT} = 0.5 V has been chosen to avoid test problems caused by tester ground degradation.

CAPACITANCE (Note 1)

| Parameter Symbol | Parameter Description | Test Conditions | | | Typ. | Unit |
|------------------|-----------------------|--------------------------|--|--------------|------|------|
| C _{IN} | Input Capacitance | V _{IN} = 2.0 V | V _{CC} = 5.0 V T _A = 25°C | CLK, OE | 9 | pF |
| | | | | Other Inputs | 2 | |
| C _{OUT} | Output Capacitance | V _{OUT} = 2.0 V | f = 1 MHz | Outputs | 4 | |

Note:

1. These parameters are not 100% tested, but are evaluated at initial characterization and at any time the design is modified where capacitance may be affected.

SWITCHING CHARACTERISTICS over COMMERCIAL operating ranges (Note 2)

| Parameter Symbol | Parameter Description | | Min. (Note 3) | Max. | Unit | | |
|------------------|--|-------------------|--------------------|--|------|----|-----|
| t _{PD} | Input or Feedback to Combinatorial Output | | 16L8, 16R6 16R4 | 3 | 10 | ns | |
| t _S | Setup Time from Input or Feedback to Clock | | 16R8, 16R6 16R4 | 10 | | ns | |
| t _H | Hold Time | | | 0 | | ns | |
| t _{CO} | Clock to Output | | | 2 | 7 | ns | |
| t _{CF} | Clock to Feedback (Note 4) | | | 2 | 6.5 | ns | |
| t _{WL} | Clock Width | LOW | | 8 | | ns | |
| | | HIGH | | 8 | | ns | |
| f _{MAX} | Maximum Frequency (Note 5) | External Feedback | | 1/(t _S + t _{CO}) | 58.8 | | MHz |
| | | Internal Feedback | | 1/(t _S + t _{CF}) | 60 | | MHz |
| | | No Feedback | | 1/(t _{WH} + t _{WL}) | 62.5 | | MHz |
| t _{PZX} | OE to Output Enable | | | | 3 | 10 | ns |
| t _{PXZ} | OE to Output Disable | | | 3 | 10 | ns | |
| t _{EA} | Input to Output Enable Using Product Term Control | | 16L8, 16R6 | 1 | 10 | ns | |
| t _{ER} | Input to Output Disable Using Product Term Control | | 16R4 | 1 | 10 | ns | |

Notes:

2. See Switching Test Circuit for test conditions.
3. Output delay minimums are measured under best-case conditions.
4. Calculated from measured f_{MAX} internal.
5. These parameters are not 100% tested, but are calculated at initial characterization and at any time the design is modified where the frequency may be affected.

2

ABSOLUTE MAXIMUM RATINGS

| | |
|--|------------------|
| Storage Temperature | -65°C to +150°C |
| Ambient Temperature with Power Applied | -55°C to +125°C |
| Supply Voltage with Respect to Ground | -0.5 V to +7.0 V |
| DC Input Voltage | -1.5 V to +5.5 V |
| DC Output or I/O Pin Voltage | 5.5 V |
| Static Discharge Voltage | 2001 V |

Stresses above those listed under Absolute Maximum Ratings may cause permanent device failure. Functionality at or above these limits is not implied. Exposure to Absolute Maximum Ratings for extended periods may affect device reliability. Programming conditions may differ. Absolute Maximum Ratings are for system design reference; parameters given are not tested.

OPERATING RANGES

Military (M) Devices (Note 1)

| | |
|--|--------------------|
| Ambient Temperature (T_A) | |
| Operating in Free Air | -55°C Min. |
| Operating Case (T_C) Temperature | 125°C Max. |
| Supply Voltage (V_{CC}) with Respect to Ground | +4.50 V to +5.50 V |

Operating ranges define those limits between which the functionality of the device is guaranteed.

Note:

1. Military products are tested at $T_C = +25^\circ\text{C}$, $+125^\circ\text{C}$, and -55°C , per MIL-STD-883.

DC CHARACTERISTICS over MILITARY operating ranges unless otherwise specified (Note 2)

| Parameter Symbol | Parameter Description | Test Conditions | Min. | Max. | Unit |
|------------------|---------------------------------------|--|------|------|---------------|
| V_{OH} | Output HIGH Voltage | $I_{OH} = -2\text{ mA}$ $V_{IN} = V_{IH}$ or V_{IL} $V_{CC} = \text{Min.}$ | 2.4 | | V |
| V_{OL} | Output LOW Voltage | $I_{OL} = 12\text{ mA}$ $V_{IN} = V_{IH}$ or V_{IL} $V_{CC} = \text{Min.}$ | | 0.5 | V |
| V_{IH} | Input HIGH Voltage | Guaranteed Input Logical HIGH Voltage for all Inputs (Note 3) | 2.0 | | V |
| V_{IL} | Input LOW Voltage | Guaranteed Input Logical LOW Voltage for all Inputs (Note 3) | | 0.8 | V |
| V_I | Input Clamp Voltage | $I_{IN} = -18\text{ mA}$, $V_{CC} = \text{Min.}$ | | -1.5 | V |
| I_{IH} | Input HIGH Current | $V_{IN} = 2.4\text{ V}$, $V_{CC} = \text{Max.}$ (Note 4) | | 25 | μA |
| I_{IL} | Input LOW Current | $V_{IN} = 0.4\text{ V}$, $V_{CC} = \text{Max.}$ (Note 4) | | -250 | μA |
| I_I | Maximum Input Current | $V_{IN} = 5.5\text{ V}$, $V_{CC} = \text{Max.}$ | | 1 | mA |
| I_{OZH} | Off-State Output Leakage Current HIGH | $V_{OUT} = 2.4\text{ V}$, $V_{CC} = \text{Max.}$ $V_{IN} = V_{IH}$ or V_{IL} (Note 4) | | 100 | μA |
| I_{OZL} | Off-State Output Leakage Current LOW | $V_{OUT} = 0.4\text{ V}$, $V_{CC} = \text{Max.}$ $V_{IN} = V_{IH}$ or V_{IL} (Note 4) | | -100 | μA |
| I_{SC} | Output Short-Circuit Current | $V_{OUT} = 0.5\text{ V}$, $V_{CC} = \text{Max.}$ (Note 5) | -30 | -130 | mA |
| I_{CC} | Supply Current | $V_{IN} = 0\text{ V}$, Outputs Open ($I_{OUT} = 0\text{ mA}$) $V_{CC} = \text{Max.}$ | | 180 | mA |

Notes:

2. For APL Products, Group A, Subgroups 1, 2, and 3 are tested per MIL-STD-883, Method 5005, unless otherwise noted.
3. V_{IL} and V_{IH} are input conditions of output tests and are not themselves directly tested. V_{IL} and V_{IH} are absolute voltages with respect to device ground and include all overshoots due to system and/or tester noise. Do not attempt to test these values without suitable equipment.
4. I/O pin leakage is the worst case of I_{IL} and I_{OZL} (or I_{IH} and I_{OZH}).
5. Not more than one output should be tested at a time. Duration of the short-circuit should not exceed one second. $V_{OUT} = 0.5\text{ V}$ has been chosen to avoid test problems caused by tester ground degradation.

CAPACITANCE (Note 1)

| Parameter Symbol | Parameter Description | Test Conditions | | | Typ. | Unit |
|------------------|-----------------------|--------------------------|--|----------------------|------|------|
| C _{IN} | Input Capacitance | V _{IN} = 2.0 V | V _{CC} = 5.0 V T _A = 25°C | CLK, \overline{OE} | 9 | pF |
| | | | | Other Inputs | 2 | |
| C _{OUT} | Output Capacitance | V _{OUT} = 2.0 V | f = 1 MHz | Outputs | 4 | |

Note:

1. These parameters are not 100% tested, but are evaluated at initial characterization and at any time the design is modified where capacitance may be affected.

SWITCHING CHARACTERISTICS over MILITARY operating ranges (Note 2)

| Parameter Symbol | Parameter Description | | | Min. (Note 3) | Max. | Unit | |
|------------------|---|-------------------|--|--------------------|------|------|-----|
| t _{PD} | Input or Feedback to Combinatorial Output | | 16L8, 16R6 16R4 | 3 | 15 | ns | |
| t _S | Setup Time from Input or Feedback to Clock | | | 15 | | ns | |
| t _H | Hold Time | | | 0 | | ns | |
| t _{CO} | Clock to Output or Feedback | | | 2 | 12 | ns | |
| t _{WL} | Clock Width | LOW | | 16R8, 16R6 16R4 | 12 | ns | |
| t _{WH} | | HIGH | | | 8 | ns | |
| f _{MAX} | Max. Frequency (Note 4) | External Feedback | 1/(t _S + t _{CO}) | | 37 | | MHz |
| | | No Feedback | 1/(t _{WH} + t _{WL}) | | 50 | | MHz |
| t _{PZX} | \overline{OE} to Output Enable (Note 5) | | | 3 | 12 | ns | |
| t _{PXZ} | \overline{OE} to Output Disable (Note 5) | | | 3 | 10 | ns | |
| t _{EA} | Input to Output Enable Using Product Term Control (Note 5) | | 16L8, 16R6 16R4 | 1 | 17 | ns | |
| t _{ER} | Input to Output Disable Using Product Term Control (Note 5) | | | 1 | 13 | ns | |

Notes:

2. See Switching Test Circuit for test conditions. For APL products Group A, Subgroups 9, 10, and 11 are tested per MIL-STD-883, Method 5005, unless otherwise noted.
3. Minimum value for t_{PD}, t_{CO}, t_{PZX}, t_{PXZ}, t_{EA}, and t_{ER} parameters should be used for simulation purposes only and are not tested.
4. These parameters are not 100% tested, but are calculated at initial characterization and at any time the design is modified where frequency may be affected.
5. These parameters are not 100% tested, but are evaluated at initial characterization and at any time the design is modified where these parameters may be affected.

2

ABSOLUTE MAXIMUM RATINGS

| | |
|--|----------------------------|
| Storage Temperature | -65°C to +150°C |
| Ambient Temperature with Power Applied | -55°C to +125°C |
| Supply Voltage with Respect to Ground | -0.5 V to +7.0 V |
| DC Input Voltage | -1.5 V to $V_{CC} + 0.5$ V |
| DC Output or I/O Pin Voltage | -0.5 V to $V_{CC} + 0.5$ V |
| DC Output Current | 16 mA |
| Static Discharge Voltage | 2001 V |

OPERATING RANGES

Commercial (C) Devices

| | | |
|-------------------------------|------------------------|--------------------|
| Ambient Temperature (T_A) | Operating in Free Air | 0°C to +75°C |
| Supply Voltage (V_{CC}) | with Respect to Ground | +4.75 V to +5.25 V |

Operating ranges define those limits between which the functionality of the device is guaranteed.

Stresses above those listed under Absolute Maximum Ratings may cause permanent device failure. Functionality at or above these limits is not implied. Exposure to Absolute Maximum Ratings for extended periods may affect device reliability. Programming conditions may differ.

DC CHARACTERISTICS over COMMERCIAL operating range unless otherwise specified

| Parameter Symbol | Parameter Description | Test Conditions | Min. | Max. | Unit |
|------------------|---------------------------------------|--|------|------|---------|
| V_{OH} | Output HIGH Voltage | $I_{OH} = 2$ mA, $V_{IN} = V_{IH}$ or V_{IL} , $V_{CC} = \text{Min.}$ | 2.4 | | V |
| V_{OL} | Output LOW Voltage | $I_{OL} = 2$ mA, $V_{IN} = V_{IH}$ or V_{IL} , $V_{CC} = \text{Min.}$ | | 0.5 | V |
| V_{IH} | Input HIGH Voltage | Guaranteed Input Logic HIGH Voltage for all inputs (Note 1) | 2.0 | | V |
| V_{IL} | Input LOW Voltage | Guaranteed Input Logical LOW Voltage for all inputs (Note 1) | | 0.8 | V |
| V_I | Input Trip Voltage | $V_{IN} = 0$ V, $V_{CC} = \text{Min.}$ | | -1.5 | V |
| I_{IH} | Input HIGH Current | $V_{IN} = 2.4$ V, $V_{CC} = \text{Max.}$ (Note 2) | | 25 | μ A |
| I_{IL} | Input LOW Current | $V_{IN} = 0.4$ V, $V_{CC} = \text{Max.}$ (Note 2) | | -250 | μ A |
| I_I | Maximum Input Current | $V_{IN} = 5.5$ V, $V_{CC} = \text{Max.}$ | | 100 | μ A |
| I_{OZH} | Off-State Output Leakage Current HIGH | $V_{OUT} = 2.4$ V, $V_{CC} = \text{Max.}$, $V_{IN} = V_{IH}$ or V_{IL} (Note 2) | | 100 | μ A |
| I_{OZL} | Off-State Output Leakage Current LOW | $V_{OUT} = 0.4$ V, $V_{CC} = \text{Max.}$, $V_{IN} = V_{IH}$ or V_{IL} (Note 2) | | -100 | μ A |
| I_{SC} | Output Short-Circuit Current | $V_{OUT} = 0.5$ V, $V_{CC} = \text{Max.}$ (Note 3) | -30 | -130 | mA |
| I_{CC} | Supply Current | $V_{IN} = 0$ V, Outputs Open ($I_{OUT} = 0$ mA), $V_{CC} = \text{Max.}$ | | 100 | mA |

Notes:

- These are absolute values with respect to device ground and all overshoots due to system and/or tester noise are included.
- I/O pin leakage is the worst case of I_{IL} and I_{OZL} (or I_{IH} and I_{OZH}).
- Not more than one output should be tested at a time. Duration of the short-circuit should not exceed one second. $V_{OUT} = 0.5$ V has been chosen to avoid test problems caused by tester ground degradation.

CAPACITANCE (Note 1)

| Parameter Symbol | Parameter Description | Test Conditions | | | Typ. | Unit |
|------------------|-----------------------|--------------------------|--|--------------|------|------|
| C _{IN} | Input Capacitance | V _{IN} = 2.0 V | V _{CC} = 5.0 V T _A = 25°C | CLK, OE | 9 | pF |
| | | | | Other Inputs | 2 | |
| C _{OUT} | Output Capacitance | V _{OUT} = 2.0 V | f = 1 MHz | Outputs | 4 | |

Note:

1. These parameters are not 100% tested, but are evaluated at initial characterization and at any time the design is modified where capacitance may be affected.

SWITCHING CHARACTERISTICS over COMMERCIAL operating ranges (Note 2)

| Parameter Symbol | Parameter Description | | Min. | Max. | Unit |
|------------------|--|-------------------|---------------------------------------|------|------|
| t _{PD} | Input or Feedback to Combinatorial Output | | 16L8, 16R6 | 15 | ns |
| t _S | Setup Time from Input or Feedback to Clock | | | | ns |
| t _H | Hold Time | | 0 | | ns |
| t _{CO} | Clock to Output | | | 12 | ns |
| t _{CF} | Clock to Feedback (Note 3) | | 16R8, 16R6 | 11 | ns |
| t _{WL} | Clock Width | LOW | 16R4 | | ns |
| | | HIGH | | | ns |
| f _{MAX} | Maximum Frequency (Note 3) | External Feedback | 1/(t _S + t _{CO}) | 37 | MHz |
| | | Internal Feedback | 1/(t _S + t _{CF}) | 38.4 | MHz |
| | | No Feedback | 1/(t _S + t _{WL}) | 52.6 | MHz |
| t _{PZX} | OE to Output Enable | | | 12 | ns |
| t _{PXZ} | OE to Output Disable | | | 10 | ns |
| t _{EA} | Input to Output Enable Using Product Term Control | | 16L8, 16R6 | 15 | ns |
| t _{ER} | Input to Output Disable Using Product Term Control | | 16R4 | 15 | ns |

Notes:

2. See Switching Test Circuit for test conditions.
3. Calculated from measured f_{MAX} internal.
4. These parameters are not 100% tested, but are calculated at initial characterization and at any time the design is modified where the frequency may be affected.

ABSOLUTE MAXIMUM RATINGS

| | |
|--|----------------------------|
| Storage Temperature | -65°C to +150°C |
| Ambient Temperature with Power Applied | -55°C to +125°C |
| Supply Voltage with Respect to Ground | -0.5 V to +7.0 V |
| DC Input Voltage | -1.5 V to $V_{CC} + 0.5$ V |
| DC Output or I/O Pin Voltage | -0.5 V to $V_{CC} + 0.5$ V |

OPERATING RANGES

Commercial (C) Devices

| | |
|--|--------------------|
| Ambient Temperature (T_A) | |
| Operating in Free Air | 0°C to +75°C |
| Supply Voltage (V_{CC}) with Respect to Ground | +4.75 V to +5.25 V |

Operating ranges define those limits between which the functionality of the device is guaranteed.

Stresses above those listed under Absolute Maximum Ratings may cause permanent device failure. Functionality at or above these limits is not implied. Exposure to Absolute Maximum Ratings for extended periods may affect device reliability. Programming conditions may differ.

DC CHARACTERISTICS over COMMERCIAL operating ranges unless otherwise specified

| Parameter Symbol | Parameter Description | Test Conditions | Min. | Max. | Unit |
|------------------|---------------------------------------|--|------|------|---------|
| V_{OH} | Output HIGH Voltage | $I_{OH} = -3.2$ mA, $V_{IN} = V_{IH}$ or V_{IL} , $V_{CC} = \text{Min.}$ | 2.4 | | V |
| V_{OL} | Output LOW Voltage | $I_{OL} = 24$ mA, $V_{IN} = V_{IH}$ or V_{IL} , $V_{CC} = \text{Min.}$ | | 0.5 | V |
| V_{IH} | Input HIGH Voltage | Guaranteed Input Logic HIGH Voltage for all Inputs (Note 1) | 2.0 | | V |
| V_{IL} | Input LOW Voltage | Guaranteed Input Logic LOW Voltage for all Inputs (Note 1) | | 0.8 | V |
| V_I | Input Clamp Voltage | $I_{IN} = 18$ mA, $V_{CC} = \text{Min.}$ | | -1.2 | V |
| I_{IH} | Input HIGH Current | $V_{IN} = 2.4$ V, $V_{CC} = \text{Max.}$ (Note 2) | | 25 | μ A |
| I_{IL} | Input LOW Current | $V_{IN} = 0$ V, $V_{CC} = \text{Max.}$ (Note 2) | | -250 | μ A |
| I_I | Maximum Input Current | $V_{IN} = 5.5$ V, $V_{CC} = \text{Max.}$ | | 100 | μ A |
| I_{OZH} | Off-State Output Leakage Current HIGH | $V_{OUT} = 2.4$ V, $V_{CC} = \text{Max.}$, $V_{IN} = V_{IH}$ or V_{IL} (Note 2) | | 100 | μ A |
| I_{OZL} | Off-State Output Leakage Current LOW | $V_{OUT} = 0.4$ V, $V_{CC} = \text{Max.}$, $V_{IN} = V_{IH}$ or V_{IL} (Note 2) | | -100 | μ A |
| I_{SC} | Output Short-Circuit Current | $V_{OUT} = 0.5$ V, $V_{CC} = \text{Max.}$ (Note 3) | -30 | -130 | mA |
| I_{CC} | Supply Current | $V_{IN} = 0$ V, Outputs Open ($I_{OUT} = 0$ mA), $V_{CC} = \text{Max.}$ | | 180 | mA |

Notes:

1. These are absolute values with respect to device ground and all overshoots due to system and/or tester noise are included.
2. I/O pin leakage is the worst case of I_{IL} and I_{OZL} (or I_{IH} and I_{OZH}).
3. Not more than one output should be tested at a time. Duration of the short-circuit should not exceed one second. $V_{OUT} = 0.5$ V has been chosen to avoid test problems caused by tester ground degradation.

CAPACITANCE (Note 1)

| Parameter Symbol | Parameter Description | Test Conditions | | Typ. | Unit |
|------------------|-----------------------|--------------------------|--|------|------|
| C _{IN} | Input Capacitance | V _{IN} = 2.0 V | V _{CC} = 5.0 V T _A = 25°C | 8 | pF |
| C _{OUT} | Output Capacitance | V _{OUT} = 2.0 V | f = 1 MHz | 9 | |

Note:

1. These parameters are not 100% tested, but are evaluated at initial characterization and at any time the design is modified where capacitance may be affected.

SWITCHING CHARACTERISTICS over COMMERCIAL operating ranges (Note 2)

| Parameter Symbol | Parameter Description | | Min. | Max. | Unit |
|------------------|--|---|--------------------|------|------|
| t _{PD} | Input or Feedback to Combinatorial Output | | 16L8, 16R6 16R4 | 15 | ns |
| t _S | Setup Time from Input or Feedback to Clock | | | | ns |
| t _H | Hold Time | | | 0 | ns |
| t _{CO} | Clock to Output or Feedback | | | 12 | ns |
| t _{WL} | Clock Width | LOW | 16R8, 16R6 | | ns |
| t _{WH} | | HIGH | 16R4 | | ns |
| f _{MAX} | Maximum Frequency (Note 3) | External Feedback (t _S + t _{CO}) | | | MHz |
| | | No Feedback (1/(t _{WH} + t _{WL})) | | 50 | MHz |
| t _{PZX} | OE to Output Disable | | | 15 | ns |
| t _{PXZ} | OE to Input Disable | | | 15 | ns |
| t _{EA} | Chip Enable Using Product Term Control | | 16L8, 16R6 | 15 | ns |
| t _{ER} | Output Output Disable Using Product Term Control | | 16R4 | 15 | ns |

Notes:

2. See Switching Test Circuit for test conditions.
3. These parameters are not 100% tested, but are calculated at initial characterization and at any time the design is modified where frequency may be affected.

2

ABSOLUTE MAXIMUM RATINGS

| | |
|--|------------------|
| Storage Temperature | -65°C to +150°C |
| Ambient Temperature with Power Applied | -55°C to +125°C |
| Supply Voltage with Respect to Ground | -0.5 V to +7.0 V |
| DC Input Voltage | -1.5 V to +5.5 V |
| DC Output or I/O Pin Voltage | 5.5 V |

Stresses above those listed under Absolute Maximum Ratings may cause permanent device failure. Functionality at or above these limits is not implied. Exposure to Absolute Maximum Ratings for extended periods may affect device reliability. Programming conditions may differ. Absolute Maximum Ratings are for system design reference; parameters given are not tested.

OPERATING RANGES

Military (M) Devices (Note 1)

| | |
|--|--------------------|
| Ambient Temperature (T_A) | |
| Operating in Free Air | -55°C Min. |
| Operating Case (T_c) Temperature | 125°C Max. |
| Supply Voltage (V_{CC}) with Respect to Ground | +4.50 V to +5.50 V |

Operating ranges define those limits between which the functionality of the device is guaranteed.

Note:

1. Military products are tested at $T_A = +25^\circ\text{C}$, $+125^\circ\text{C}$, and -55°C , per MIL-STD-883.

DC CHARACTERISTICS over MILITARY operating ranges unless otherwise specified (Note 2)

| Parameter Symbol | Parameter Description | Test Conditions | Min. | Max. | Unit |
|------------------|---------------------------------------|---|------|------|---------------|
| V_{OH} | Output HIGH Voltage | $I_{OH} = -2.4 \text{ mA}$, $V_{IN} = V_{IH}$ or V_{IL} , $V_{CC} = \text{Min.}$ | 2.4 | | V |
| V_{OL} | Output LOW Voltage | $I_{OL} = 2.4 \text{ mA}$, $V_{IN} = V_{IH}$ or V_{IL} , $V_{CC} = \text{Min.}$ | | 0.5 | V |
| V_{IH} | Input HIGH Voltage | Guaranteed Input Logic HIGH Voltage for all Inputs (Note 3) | 2.0 | | V |
| V_{IL} | Input LOW Voltage | Guaranteed Input Logic LOW Voltage for all Inputs (Note 3) | | 0.8 | V |
| V_I | Input Clamp Voltage | $I_{IN} = -1.5 \text{ mA}$, $V_{CC} = \text{Min.}$ | | -1.5 | V |
| I_{IH} | Input HIGH Current | $V_{IN} = 2.4 \text{ V}$, $V_{CC} = \text{Max.}$ (Note 4) | | 25 | μA |
| I_{IL} | Input LOW Current | $V_{IN} = 0.4 \text{ V}$, $V_{CC} = \text{Max.}$ (Note 4) | | -250 | μA |
| I_I | Maximum Input Current | $V_{IN} = 5.5 \text{ V}$, $V_{CC} = \text{Max.}$ | | 1 | mA |
| I_{OZH} | Off-State Output Leakage Current HIGH | $V_{OUT} = 2.4 \text{ V}$, $V_{CC} = \text{Max.}$, $V_{IN} = V_{IH}$ or V_{IL} (Note 4) | | 100 | μA |
| I_{OZL} | Off-State Output Leakage Current LOW | $V_{OUT} = 0.4 \text{ V}$, $V_{CC} = \text{Max.}$, $V_{IN} = V_{IH}$ or V_{IL} (Note 4) | | -100 | μA |
| I_{SC} | Output Short-Circuit Current | $V_{OUT} = 0.5 \text{ V}$, $V_{CC} = \text{Max.}$ (Note 5) | -30 | -130 | mA |
| I_{CC} | Supply Current | $V_{IN} = 0 \text{ V}$, Outputs Open ($I_{OUT} = 0 \text{ mA}$), $V_{CC} = \text{Max.}$ | | 180 | mA |

Notes:

2. For APL Products, Group A, Subgroups 1, 2, and 3 are tested per MIL-STD-883, Method 5005, unless otherwise noted.
3. V_{IL} and V_{IH} are input conditions of output tests and are not themselves directly tested. V_{IL} and V_{IH} are absolute voltages with respect to device ground and include all overshoots due to system and/or tester noise. Do not attempt to test these values without suitable equipment.
4. I/O pin leakage is the worst case of I_{IL} and I_{OZL} (or I_{IH} and I_{OZH}).
5. Not more than one output should be tested at a time. Duration of the short-circuit should not exceed one second. $V_{OUT} = 0.5 \text{ V}$ has been chosen to avoid test problems caused by tester ground degradation.

CAPACITANCE (Note 1)

| Parameter Symbol | Parameter Description | Test Conditions | | Typ. | Unit |
|------------------|-----------------------|--------------------------|--|------|------|
| C _{IN} | Input Capacitance | V _{IN} = 2.0 V | V _{CC} = 5.0 V T _A = 25°C | 9 | pF |
| C _{OUT} | Output Capacitance | V _{OUT} = 2.0 V | f = 1 MHz | 10 | |

Note:

1. These parameters are not 100% tested, but are evaluated at initial characterization and at any time the design is modified where capacitance may be affected.

SWITCHING CHARACTERISTICS over MILITARY operating ranges (Note 2)

| Parameter Symbol | Parameter Description | | Min. | Max. | Unit |
|------------------|---|---|--------------------|------|------|
| t _{PD} | Input or Feedback to Combinatorial Output | | 16L8, 16R6 16R4 | 20 | ns |
| t _S | Setup Time from Input or Feedback to Clock | | | | ns |
| t _H | Hold Time | | | 0 | ns |
| t _{CO} | Clock to Output or Feedback | | | 15 | ns |
| t _{WL} | Clock Width | LOW | 16R8, 16R6 | | ns |
| t _{WH} | | HIGH | 16R4 | | ns |
| f _{MAX} | Maximum Frequency (Note 3) | External Feedback (1/t _S + t _{CO}) | | 2 | MHz |
| | | No Feedback | | | 41.6 |
| t _{PZX} | OE to Output Enable (Note 4) | | | 20 | ns |
| t _{XPZ} | OE to Output Disable (Note 4) | | | 20 | ns |
| t _{EA} | Input to Output Enable Using Product Term Control (Note 4) | | | 25 | ns |
| t _{ER} | Input to Output Disable Using Product Term Control (Note 4) | | 16L8, 16R6 16R4 | 20 | ns |

Notes:

2. See Switching Test Circuit for test conditions. For APL products Group A, Subgroups 9, 10, and 11 are tested per MIL-STD-883, Method 5005, unless otherwise noted.
3. These parameters are not 100% tested, but are calculated at initial characterization and at any time the design is modified where frequency may be affected.
4. These parameters are not 100% tested, but are evaluated at initial characterization and at any time the design is modified where these parameters may be affected.

2

ABSOLUTE MAXIMUM RATINGS

| | |
|--|----------------------------|
| Storage Temperature | -65°C to +150°C |
| Ambient Temperature with Power Applied | -55°C to +125°C |
| Supply Voltage with Respect to Ground | -0.5 V to +7.0 V |
| DC Input Voltage | -1.5 V to $V_{CC} + 0.5$ V |
| DC Output or I/O Pin Voltage | -0.5 V to $V_{CC} + 0.5$ V |

OPERATING RANGES

Commercial (C) Devices

| | | |
|--|-----------------------|--------------------|
| Ambient Temperature (T_A) | Operating in Free Air | 0°C to +75°C |
| Supply Voltage (V_{CC}) with Respect to Ground | | +4.75 V to +5.25 V |

Operating ranges define those limits between which the functionality of the device is guaranteed.

Stresses above those listed under Absolute Maximum Ratings may cause permanent device failure. Functionality at or above these limits is not implied. Exposure to Absolute Maximum Ratings for extended periods may affect device reliability. Programming conditions may differ.

DC CHARACTERISTICS over COMMERCIAL operating ranges unless otherwise specified

| Parameter Symbol | Parameter Description | Test Conditions | Min. | Max. | Unit |
|------------------|---------------------------------------|--|------|------|---------|
| V_{OH} | Output HIGH Voltage | $I_{OH} = -3.2$ mA, $V_{IN} = V_{IH}$ or V_{IL} , $V_{CC} = \text{Min.}$ | 2.4 | | V |
| V_{OL} | Output LOW Voltage | $I_{OL} = 24$ mA, $V_{IN} = V_{IH}$ or V_{IL} , $V_{CC} = \text{Min.}$ | | 0.5 | V |
| V_{IH} | Input HIGH Voltage | Guaranteed Input Logic HIGH Voltage for all Inputs (Note 1) | | | V |
| V_{IL} | Input LOW Voltage | Guaranteed Input Logic LOW Voltage for all Inputs (Note 1) | | 0.8 | V |
| V_I | Input Clamp Voltage | $I_{IN} = -16$ mA, $V_{CC} = \text{Max.}$ | | -1.2 | V |
| I_{IH} | Input HIGH Current | $V_{IN} = 2.7$ V, $V_{CC} = \text{Max.}$ (Note 2) | | 25 | μ A |
| I_{IL} | Input LOW Current | $V_{IN} = 0.4$ V, $V_{CC} = \text{Max.}$ (Note 2) | | -100 | μ A |
| I_I | Maximum Input Current | $V_{IN} = 5.5$ V, $V_{CC} = \text{Max.}$ | | 100 | μ A |
| I_{OZH} | Off-State Output Leakage Current HIGH | $V_{OUT} = 2.7$ V, $V_{CC} = \text{Max.}$, $V_{IN} = V_{IH}$ or V_{IL} (Note 2) | | 100 | μ A |
| I_{OZL} | Off-State Output Leakage Current LOW | $V_{OUT} = 0.4$ V, $V_{CC} = \text{Max.}$, $V_{IN} = V_{IH}$ or V_{IL} (Note 2) | | -100 | μ A |
| I_{SC} | Output Short-Circuit Current | $V_{OUT} = 0.5$ V, $V_{CC} = \text{Max.}$ (Note 3) | -30 | -130 | mA |
| I_{CC} | Supply Current | $V_{IN} = 0$ V, Outputs Open ($I_{OUT} = 0$ mA), $V_{CC} = \text{Max.}$ | | 90 | mA |

Notes:

- These are absolute values with respect to device ground and all overshoots due to system and/or tester noise are included.
- I/O pin leakage is the worst case of I_{IL} and I_{OZL} (or I_{IH} and I_{OZH}).
- Not more than one output should be tested at a time. Duration of the short-circuit should not exceed one second. $V_{OUT} = 0.5$ V has been chosen to avoid test problems caused by tester ground degradation.

CAPACITANCE (Note 1)

| Parameter Symbol | Parameter Description | Test Conditions | | Typ. | Unit |
|------------------|-----------------------|--------------------------|---|------|------|
| C _{IN} | Input Capacitance | V _{IN} = 2.0 V | V _{CC} = 5.0 V T _A = 25°C f = 1 MHz | 7 | pF |
| C _{OUT} | Output Capacitance | V _{OUT} = 2.0 V | | 7 | |

Note:

1. These parameters are not 100% tested, but are evaluated at initial characterization and at any time the design is modified where capacitance may be affected.

SWITCHING CHARACTERISTICS over COMMERCIAL operating ranges (Note 2)

| Parameter Symbol | Parameter Description | | Min. | Max. | Unit |
|------------------|---|--------------------------------------|--------------------|------|------|
| t _{PD} | Input or Feedback to Combinatorial Output | | 16L8, 16R6 16R4 | 25 | ns |
| t _S | Setup Time from Input or Feedback to Clock | | | | ns |
| t _H | Hold Time | | | 0 | ns |
| t _{CO} | Clock to Output | | | 15 | ns |
| t _{CF} | Clock to Feedback (Note 3) | | 16R8, 16R6 | 10 | ns |
| t _{WL} | Clock Width | LOW | 16R4 | 15 | ns |
| | | HIGH | | | |
| f _{MAX} | Maximum Frequency (Note 4) | External Feedback $1/(t_s + t_{CO})$ | | 25 | MHz |
| | | Internal Feedback $1/(t_s + t_{CF})$ | | 28.5 | MHz |
| | | No Feedback $1/(t_{WH} + t_{WL})$ | | 33 | MHz |
| t _{PZX} | OE to Output Enable | | | 20 | ns |
| t _{PXZ} | OE to Output Disable | | | 20 | ns |
| t _{EA} | Input to Output Enable Using Product Term Control | | 16L8, 16R6 | 25 | ns |
| t _{ER} | Input to Output Enable Using Product Term Control | | 16R4 | 25 | ns |

Notes:

2. See Switching Test Circuit for test conditions.
3. Calculated from measured f_{MAX} internal.
4. These parameters are not 100% tested, but are calculated at initial characterization and at any time the design is modified where frequency may be affected.

2

ABSOLUTE MAXIMUM RATINGS

| | |
|--|------------------|
| Storage Temperature | -65°C to +150°C |
| Ambient Temperature with Power Applied | -55°C to +125°C |
| Supply Voltage with Respect to Ground | -0.5 V to +7.0 V |
| DC Input Voltage | -1.5 V to +5.5 V |
| DC Output or I/O Pin Voltage | 5.5 V |

Stresses above those listed under Absolute Maximum Ratings may cause permanent device failure. Functionality at or above these limits is not implied. Exposure to Absolute Maximum Ratings for extended periods may affect device reliability. Programming conditions may differ. Absolute Maximum Ratings are for system design reference; parameters given are not tested.

OPERATING RANGES

Military (M) Devices (Note 1)

| | |
|--|--------------------|
| Ambient Temperature (T _A) | |
| Operating in Free Air | -55°C Min. |
| Operating Case (T _c) Temperature | 125°C Max. |
| Supply Voltage (V _{CC}) with Respect to Ground | +4.50 V to +5.50 V |

Operating ranges define those limits between which the functionality of the device is guaranteed.

Note:

1. Military products are tested at +25°C, +125°C, and -55°C, per MIL-STD-883.

DC CHARACTERISTICS over MILITARY operating ranges unless otherwise specified (Note 2)

| Parameter Symbol | Parameter Description | Test Conditions | Min. | Max. | Unit |
|------------------|---------------------------------------|---|------|------|------|
| V _{OH} | Output HIGH Voltage | I _{OH} = 0 mA, V _{IN} = V _{IH} or V _{IL} , V _{CC} = Min. | 2.4 | | V |
| V _{OL} | Output LOW Voltage | I _{OL} = 0 mA, V _{IN} = V _{IH} or V _{IL} , V _{CC} = Min. | | 0.5 | V |
| V _{IH} | Input HIGH Voltage | Guaranteed Input Logic HIGH Voltage for all Inputs | 2.0 | | V |
| V _{IL} | Input LOW Voltage | Guaranteed Input Logic LOW Voltage for all Inputs (Note 3) | | 0.8 | V |
| V _I | Input Clamp Voltage | V _{IN} = -1.5 V, V _{CC} = Min. | | -1.5 | V |
| I _{IH} | Input HIGH Current | V _{IN} = 2.4 V, V _{CC} = Max. (Note 4) | | 25 | μA |
| I _{IL} | Input LOW Current | V _{IN} = 0.4 V, V _{CC} = Max. (Note 4) | | -250 | μA |
| I _I | Maximum Input Current | V _{IN} = 5.5 V, V _{CC} = Max. | | 1 | mA |
| I _{ozH} | Off-State Output Leakage Current HIGH | V _{OUT} = 2.4 V, V _{CC} = Max. V _{IN} = V _{IH} or V _{IL} (Note 4) | | 100 | μA |
| I _{ozL} | Off-State Output Leakage Current LOW | V _{OUT} = 0.4 V, V _{CC} = Max. V _{IN} = V _{IH} or V _{IL} (Note 4) | | -100 | μA |
| I _{sc} | Output Short-Circuit Current | V _{OUT} = 0.5 V, V _{CC} = Max. (Note 5) | -30 | -130 | mA |
| I _{CC} | Supply Current | V _{IN} = 0 V, Outputs Open (I _{OUT} = 0 mA) V _{CC} = Max. | | 90 | mA |

Notes:

2. For APL Products, Group A, Subgroups 1, 2, and 3 are tested per MIL-STD-883, Method 5005, unless otherwise noted.
3. V_{IL} and V_{IH} are input conditions of output tests and are not themselves directly tested. V_{IL} and V_{IH} are absolute voltages with respect to device ground and include all overshoots due to system and/or tester noise. Do not attempt to test these values without suitable equipment.
4. I/O pin leakage is the worst case of I_{IL} and I_{ozL} (or I_{IH} and I_{ozH}).
5. Not more than one output should be tested at a time. Duration of the short-circuit should not exceed one second. V_{OUT} = 0.5 V has been chosen to avoid test problems caused by tester ground degradation.

CAPACITANCE (Note 1)

| Parameter Symbol | Parameter Description | Test Conditions | | Typ. | Unit |
|------------------|-----------------------|--------------------------|--|------|------|
| C _{IN} | Input Capacitance | V _{IN} = 2.0 V | V _{CC} = 5.0 V T _A = 25°C | 7 | pF |
| C _{OUT} | Output Capacitance | V _{OUT} = 2.0 V | f = 1 MHz | 7 | |

Note:

1. These parameters are not 100% tested, but are evaluated at initial characterization and at any time the design is modified where capacitance may be affected.

SWITCHING CHARACTERISTICS over MILITARY operating ranges (Note 2)

| Parameter Symbol | Parameter Description | | Min. | Max. | Unit |
|------------------|---|---|--------------------|------|------|
| t _{PD} | Input or Feedback to Combinatorial Output | | 16L8, 16R6 16R4 | 30 | ns |
| t _S | Setup Time from Input or Feedback to Clock | | | 30 | ns |
| t _H | Hold Time | | | 0 | ns |
| t _{CO} | Clock to Output or Feedback | | | 20 | ns |
| t _{WL} | Clock Width | LOW | 16R8, 16R6 16R4 | 20 | ns |
| t _{WH} | | HIGH | | 20 | ns |
| f _{MAX} | Maximum Frequency (Note 3) | External Feedback (1/t _S + t _{CO}) | | 25 | MHz |
| | | No Feedback (1/(t _{WH} + t _{WL})) | | 25 | MHz |
| t _{PZX} | OE to Output Enable (Note 4) | | | 25 | ns |
| t _{PXZ} | OE to Output Disable (Note 4) | | | 25 | ns |
| t _{EA} | Input to Output Enable Using Product Term Control (Note 4) | | 16L8, 16R6 16R4 | 30 | ns |
| t _{ER} | Input to Output Disable Using Product Term Control (Note 4) | | | 30 | ns |

Notes:

2. See Switching Test Circuit for test conditions. For APL products Group A, Subgroups 9, 10, and 11 are tested per MIL-STD-883, Method 5005, unless otherwise noted.
3. These parameters are not 100% tested, but are calculated at initial characterization and at any time the design is modified where frequency may be affected.
4. These parameters are not 100% tested, but are evaluated at initial characterization and at any time the design is modified where these parameters may be affected.

2

ABSOLUTE MAXIMUM RATINGS

| | |
|--|----------------------------|
| Storage Temperature | -65°C to +150°C |
| Ambient Temperature with Power Applied | -55°C to +125°C |
| Supply Voltage with Respect to Ground | -0.5 V to +7.0 V |
| DC Input Voltage | -1.5 V to $V_{CC} + 0.5$ V |
| DC Output or I/O Pin Voltage | -0.5 V to $V_{CC} + 0.5$ V |

Stresses above those listed under Absolute Maximum Ratings may cause permanent device failure. Functionality at or above these limits is not implied. Exposure to Absolute Maximum Ratings for extended periods may affect device reliability. Programming conditions may differ.

OPERATING RANGES

Commercial (C) Devices

| | |
|--|--------------------|
| Ambient Temperature (T_A) | 0°C to +75°C |
| Operating in Free Air | 0°C to +75°C |
| Supply Voltage (V_{CC}) with Respect to Ground | +4.75 V to +5.25 V |

Operating ranges define those limits between which the functionality of the device is guaranteed.

DC CHARACTERISTICS over COMMERCIAL operating ranges unless otherwise specified

| Parameter Symbol | Parameter Description | Test Conditions | Min. | Max. | Unit |
|------------------|---------------------------------------|---|--|------|---------|
| V_{OH} | Output HIGH Voltage | $I_{OH} = -3.2$ mA ($V_{IN} = V_{IH}$ or V_{IL} , $V_{CC} = \text{Min.}$) | 2.4 | | V |
| V_{OL} | Output LOW Voltage | $I_{OL} = 24$ mA ($V_{IN} = V_{IH}$ or V_{IL} , $V_{CC} = \text{Min.}$) | | 0.5 | V |
| V_{IH} | Input HIGH Voltage | Guaranteed Input Logic Voltage (Voltage for all Inputs) (Note 1) | | | V |
| V_{IL} | Input LOW Voltage | Guaranteed Input Logic Voltage for all Inputs (Note 1) | | 0.8 | V |
| V_I | Input Pin Voltage | $I_{IN} = 16$ mA, $V_{CC} = \text{Min.}$ | | -1.2 | V |
| I_{IH} | Input HIGH Current | $V_{IN} = 2.7$ V, $V_{CC} = \text{Max.}$ (Note 2) | | 25 | μ A |
| I_{IL} | Input LOW Current | $V_{IN} = 0.4$ V, $V_{CC} = \text{Max.}$ (Note 2) | | -250 | μ A |
| I_I | Maximum Input Current | $V_{IN} = 5.5$ V, $V_{CC} = \text{Max.}$ | | 100 | μ A |
| I_{OZH} | Off-State Output Leakage Current HIGH | $V_{OUT} = 2.7$ V, $V_{CC} = \text{Max.}$ $V_{IN} = V_{IH}$ or V_{IL} (Note 2) | | 100 | μ A |
| I_{OZL} | Off-State Output Leakage Current LOW | $V_{OUT} = 0.4$ V, $V_{CC} = \text{Max.}$ $V_{IN} = V_{IH}$ or V_{IL} (Note 2) | | -100 | μ A |
| I_{SC} | Output Short-Circuit Current | $V_{OUT} = 0.5$ V, $V_{CC} = \text{Max.}$ (Note 3) | -30 | -130 | mA |
| I_{CC} | Supply Current | 16L8 | $V_{IN} = 0$ V, Outputs Open ($I_{OUT} = 0$ mA) | 155 | mA |
| | | 16R8/6/4 | $V_{CC} = \text{Max.}$ | 180 | |

Notes:

- These are absolute values with respect to device ground and all overshoots due to system and/or tester noise are included.
- I/O pin leakage is the worst case of I_{IL} and I_{OZL} (or I_{IH} and I_{OZH}).
- Not more than one output should be tested at a time. Duration of the short-circuit should not exceed one second. $V_{CC} = 0.5$ V has been chosen to avoid test problems caused by tester ground degradation.

CAPACITANCE (Note 1)

| Parameter Symbol | Parameter Description | Test Conditions | | Typ. | Unit |
|------------------|-----------------------|--------------------------|--|------|------|
| C _{IN} | Input Capacitance | V _{IN} = 2.0 V | V _{CC} = 5.0 V T _A = 25°C | 7 | pF |
| C _{OUT} | Output Capacitance | V _{OUT} = 2.0 V | f = 1 MHz | 7 | |

Note:

1. These parameters are not 100% tested, but are evaluated at initial characterization and at any time the design is modified where capacitance may be affected.

SWITCHING CHARACTERISTICS over COMMERCIAL operating ranges (Note 2)

| Parameter Symbol | Parameter Description | | Max. | Unit |
|------------------|---|--------------------------------------|------|------|
| t _{PD} | Input or Feedback to Combinatorial Output | | 25 | ns |
| t _S | Setup Time from Input or Feedback to Clock | | | ns |
| t _H | Hold Time | | 0 | ns |
| t _{CO} | Clock to Output | | 15 | ns |
| t _{CF} | Clock to Feedback (Note 3) | | 10 | ns |
| t _{WL} | Clock Width | LOW | | ns |
| t _{WH} | | HIGH | | ns |
| f _{MAX} | Maximum Frequency (Note 4) | External Feedback $1/(t_s + t_{co})$ | 25 | MHz |
| | | Internal Feedback $1/(t_s + t_{cf})$ | 28.5 | MHz |
| | | No Feedback $1/(t_{wh} + t_{wl})$ | 33 | MHz |
| t _{PZX} | Output Enable | | 20 | ns |
| t _{PXZ} | Output Disable | | 20 | ns |
| t _{EA} | Input to Output Enable Using Product Term Control | | 25 | ns |
| t _{ER} | Input to Output Enable Using Product Term Control | | 25 | ns |

Notes:

2. See Switching Test Circuit for test conditions.
3. Calculated from measured f_{MAX} internal.
4. These parameters are not 100% tested, but are calculated at initial characterization and at any time the design is modified where frequency may be affected.

2

ABSOLUTE MAXIMUM RATINGS

| | |
|--|------------------|
| Storage Temperature | -65°C to +150°C |
| Ambient Temperature with Power Applied | -55°C to +125°C |
| Supply Voltage with Respect to Ground | -0.5 V to +7.0 V |
| DC Input Voltage | -1.5 V to +5.5 V |
| DC Output or I/O Pin Voltage | 5.5 V |

Stresses above those listed under Absolute Maximum Ratings may cause permanent device failure. Functionality at or above these limits is not implied. Exposure to Absolute Maximum Ratings for extended periods may affect device reliability. Programming conditions may differ. Absolute Maximum Ratings are for system design reference; parameters given are not tested.

OPERATING RANGES

Military (M) Devices (Note 1)

| | |
|--|--------------------|
| Ambient Temperature (T _A) | -55°C Min. |
| Operating in Free Air | |
| Operating Case (T _c) Temperature | 125°C Max. |
| Supply Voltage (V _{CC}) with Respect to Ground | +4.50 V to +5.50 V |

Operating ranges define those limits between which the functionality of the device is guaranteed.

Note:

1. Military products are tested at +25°C, +125°C, and -55°C, per MIL-STD-883.

DC CHARACTERISTICS over MILITARY operating ranges unless otherwise specified (Note 2)

| Parameter Symbol | Parameter Description | Test Conditions | Min. | Max. | Unit |
|------------------|---------------------------------------|---|------|------|------|
| V _{OH} | Output HIGH Voltage | I _{OH} = 1 mA, V _{IN} = V _{IH} or V _{IL} , V _{CC} = Min. | 2.4 | | V |
| V _{OL} | Output LOW Voltage | I _{OL} = 1 mA, V _{IN} = V _{IH} or V _{IL} , V _{CC} = Min. | | 0.5 | V |
| V _{IH} | Input HIGH Voltage | Guaranteed Input Logic HIGH Voltage for all Inputs (Note 3) | 2.0 | | V |
| V _{IL} | Input LOW Voltage | Guaranteed Input Logic LOW Voltage for all Inputs (Note 3) | | 0.8 | V |
| V _I | Input Clamp Voltage | V _{IN} = -1.5 V, V _{CC} = Min. | | -1.5 | V |
| I _{IH} | Input HIGH Current | V _{IN} = 2.4 V, V _{CC} = Max. (Note 4) | | 25 | μA |
| I _{IL} | Input LOW Current | V _{IN} = 0.4 V, V _{CC} = Max. (Note 4) | | -250 | μA |
| I _I | Maximum Input Current | V _{IN} = 5.5 V, V _{CC} = Max. | | 1 | mA |
| I _{OZH} | Off-State Output Leakage Current HIGH | V _{OUT} = 2.4 V, V _{CC} = Max. V _{IN} = V _{IH} or V _{IL} (Note 4) | | 100 | μA |
| I _{OZL} | Off-State Output Leakage Current LOW | V _{OUT} = 0.4 V, V _{CC} = Max. V _{IN} = V _{IH} or V _{IL} (Note 4) | | -100 | μA |
| I _{SC} | Output Short-Circuit Current | V _{OUT} = 0.5 V, V _{CC} = Max. (Note 5) | -30 | -130 | mA |
| I _{CC} | Supply Current | V _{IN} = 0 V, Outputs Open (I _{OUT} = 0 mA) V _{CC} = Max. | | 180 | mA |

Notes:

2. For APL Products, Group A, Subgroups 1, 2, and 3 are tested per MIL-STD-883, Method 5005, unless otherwise noted.
3. V_{IL} and V_{IH} are input conditions of output tests and are not themselves directly tested. V_{IL} and V_{IH} are absolute voltages with respect to device ground and include all overshoots due to system and/or tester noise. Do not attempt to test these values without suitable equipment.
4. I/O pin leakage is the worst case of I_{IL} and I_{OZL} (or I_{IH} and I_{OZH}).
5. Not more than one output should be tested at a time. Duration of the short-circuit should not exceed one second. V_{OUT} = 0.5 V has been chosen to avoid test problems caused by tester ground degradation.

CAPACITANCE (Note 1)

| Parameter Symbol | Parameter Description | Test Conditions | | Typ. | Unit |
|------------------|-----------------------|--------------------------|--|------|------|
| C _{IN} | Input Capacitance | V _{IN} = 2.0 V | V _{CC} = 5.0 V T _A = 25°C | 7 | pF |
| C _{OUT} | Output Capacitance | V _{OUT} = 2.0 V | f = 1 MHz | 7 | |

Note:

1. These parameters are not 100% tested, but are evaluated at initial characterization and at any time the design is modified where capacitance may be affected.

SWITCHING CHARACTERISTICS over MILITARY operating ranges (Note 2)

| Parameter Symbol | Parameter Description | | Min. | Max. | Unit |
|------------------|--|---|--------------------|------|------|
| t _{PD} | Input or Feedback to Combinatorial Output | | 16L8, 16R6 1 | 30 | ns |
| t _S | Setup Time from Input or Feedback to Clock | | | | ns |
| t _H | Hold Time | | | 0 | ns |
| t _{CO} | Clock to Output or Feedback | | | 20 | ns |
| t _{WL} | Clock Width | LOW | 16R8, 16R6 | 2 | ns |
| t _{WH} | | HIGH | 16R8 | 2 | ns |
| f _{MAX} | Maximum Frequency (Note 3) | External Feedback 1/(t _{WH} + t _{WL} + t _{CO}) | | | MHz |
| | | No Feedback 1/(t _{WH} + t _{WL}) | | 25 | MHz |
| t _{PZX} | OE to Output Enable (Note 4) | | | 25 | ns |
| t _{PXZ} | OE to Output Disable (Note 4) | | | 25 | ns |
| t _{EA} | Input to Output Enable Using Product Term Control (Note 4) | | 16L8, 16R6 16R4 | 30 | ns |
| t _{ER} | Output to Output Disable Using Product Term Control (Note 4) | | | 30 | ns |

Notes:

2. See Switching Test Circuit for test conditions. For APL products Group A, Subgroups 9, 10, and 11 are tested per MIL-STD-883, Method 5005, unless otherwise noted.
3. These parameters are not 100% tested, but are calculated at initial characterization and at any time the design is modified where frequency may be affected.
4. These parameters are not 100% tested, but are evaluated at initial characterization and at any time the design is modified where these parameters may be affected.

2

ABSOLUTE MAXIMUM RATINGS

| | |
|--|------------------|
| Storage Temperature | -65°C to +150°C |
| Ambient Temperature with Power Applied | -55°C to +125°C |
| Supply Voltage with Respect to Ground | -0.5 V to +7.0 V |
| DC Input Voltage | -1.5 V to +5.5 V |
| DC Output or I/O Pin Voltage | 5.5 V |

Stresses above those listed under Absolute Maximum Ratings may cause permanent device failure. Functionality at or above these limits is not implied. Exposure to Absolute Maximum Ratings for extended periods may affect device reliability. Programming conditions may differ.

OPERATING RANGES

Commercial (C) Devices

| | |
|--|--------------------|
| Ambient Temperature (T _A) | |
| Operating in Free Air | 0°C to +75°C |
| Supply Voltage (V _{CC}) with Respect to Ground | +4.75 V to +5.25 V |

Operating ranges define those limits between which the functionality of the device is guaranteed.

DC CHARACTERISTICS over COMMERCIAL operating ranges unless otherwise specified

| Parameter Symbol | Parameter Description | Test Conditions | Min. | Max. | Unit |
|------------------|---------------------------------------|---|------|------|------|
| V _{OH} | Output HIGH Voltage | I _{OH} = -1 mA, V _{IN} = V _{IH} or V _{IL} , V _{CC} = Min. | 2.4 | | V |
| V _{OL} | Output LOW Voltage | I _{OL} = 8 mA, V _{IN} = V _{IH} or V _{IL} , V _{CC} = Min. | | 0.5 | V |
| V _{IH} | Input HIGH Voltage | Guaranteed Input Logic HIGH Voltage for all Inputs (Note 1) | 2.0 | | V |
| V _{IL} | Input LOW Voltage | Guaranteed Input Logic LOW Voltage for all Inputs (Note 1) | | 0.8 | V |
| V _I | Input Clamp Voltage | I _{IN} = 10 mA, V _{CC} = Min. | | -1.5 | V |
| I _{IH} | Input HIGH Current | V _{IN} = 2.4 V, V _{CC} = Max. (Note 2) | | 25 | μA |
| I _{IL} | Input LOW Current | V _{IN} = 0.4 V, V _{CC} = Max. (Note 2) | | -250 | μA |
| I _I | Maximum Input Current | V _{IN} = 5.5 V, V _{CC} = Max. | | 100 | μA |
| I _{ozH} | Off-State Output Leakage Current HIGH | V _{OUT} = 2.4 V, V _{CC} = Max. V _{IN} = V _{IH} or V _{IL} (Note 2) | | 100 | μA |
| I _{ozL} | Off-State Output Leakage Current LOW | V _{OUT} = 0.4 V, V _{CC} = Max. V _{IN} = V _{IH} or V _{IL} (Note 2) | | -100 | μA |
| I _{sc} | Output Short-Circuit Current | V _{OUT} = 0.5 V, V _{CC} = Max. (Note 3) | -30 | -250 | mA |
| I _{CC} | Supply Current | V _{IN} = 0 V, Outputs Open (I _{OUT} = 0 mA) V _{CC} = Max. | | 55 | mA |

Notes:

1. These are absolute values with respect to device ground and all overshoots due to system and/or tester noise are included.
2. I/O pin leakage is the worst case of I_{IL} and I_{ozL} (or I_{IH} and I_{ozH}).
3. Not more than one output should be tested at a time. Duration of the short-circuit should not exceed one second. V_{OUT} = 0.5 V as been chosen to avoid test problems caused by tester ground degradation.

SWITCHING CHARACTERISTICS over COMMERCIAL operating ranges (Note 1)

| Parameter Symbol | Parameter Description | | Min. | Max. | Unit |
|------------------|--|-------------------|--|------|------|
| t _{PD} | Input or Feedback to Combinatorial Output | | | 35 | ns |
| t _S | Setup Time from Input or Feedback to Clock | | 35 | | ns |
| t _H | Hold Time | | 0 | | ns |
| t _{CO} | Clock to Output or Feedback | | | 25 | ns |
| t _{WL} | Clock Width | LOW | 25 | | ns |
| t _{WH} | | HIGH | 25 | | ns |
| f _{MAX} | Maximum Frequency (Note 2) | External Feedback | 1/(t _S + t _{CO}) | 16 | MHz |
| | | No Feedback | 1/(t _{WH} + t _{WL}) | 20 | MHz |
| t _{PZX} | OE to Output Enable | | | 25 | ns |
| t _{PXZ} | OE to Output Disable | | | 25 | ns |
| t _{EA} | Input to Output Enable Using Product Term Control | | 16L8, 16R6 | 35 | ns |
| t _{ER} | Input to Output Disable Using Product Term Control | | 16R4 | 35 | ns |

Notes:

1. See Switching Test Circuit for test conditions.
2. These parameters are not 100% tested and are based on initial characterization data. Any time the design is modified where frequency may be affected.

FOR CMOS SEE PALCE16V18

ABSOLUTE MAXIMUM RATINGS

| | |
|--|------------------|
| Storage Temperature | -65°C to +150°C |
| Ambient Temperature with Power Applied | -55°C to +125°C |
| Supply Voltage with Respect to Ground | -0.5 V to +7.0 V |
| DC Input Voltage | -1.5 V to +5.5 V |
| DC Output or I/O Pin Voltage | 5.5 V |

Stresses above those listed under Absolute Maximum Ratings may cause permanent device failure. Functionality at or above these limits is not implied. Exposure to Absolute Maximum Ratings for extended periods may affect device reliability. Programming conditions may differ. Absolute Maximum Ratings are for system design reference; parameters given are not tested.

OPERATING RANGES

Military (M) Devices (Note 1)

| | |
|--|--------------------|
| Ambient Temperature (T_A) | -55°C Min. |
| Operating in Free Air | |
| Operating Case (T_c) Temperature | 125°C Max. |
| Supply Voltage (V_{CC}) with Respect to Ground | +4.50 V to +5.50 V |

Operating ranges define those limits between which the functionality of the device is guaranteed.

Note:

1. Military products are tested at $T_C = +25^\circ\text{C}$, $+125^\circ\text{C}$, and -55°C , per MIL-STD-883.

DC CHARACTERISTICS over MILITARY operating ranges unless otherwise specified (Note 2)

| Parameter Symbol | Parameter Description | Test Conditions | Min. | Max. | Unit |
|------------------|---------------------------------------|--|------|------|---------------|
| V_{OH} | Output HIGH Voltage | $I_{OH} = -1 \text{ mA}$ $V_{IN} = V_{IH}$ or V_{IL} $V_{CC} = \text{Min.}$ | 2.4 | | V |
| V_{OL} | Output LOW Voltage | $I_{OL} = 4 \text{ mA}$ $V_{IN} = V_{IH}$ or V_{IL} $V_{CC} = \text{Min.}$ | | 0.5 | V |
| V_{IH} | Input HIGH Voltage | Guaranteed Input Logical HIGH Voltage for all Inputs (Note 3) | 2.0 | | V |
| V_{IL} | Input LOW Voltage | Guaranteed Input Logical LOW Voltage for all Inputs (Note 3) | | 0.8 | V |
| V_I | Input Clamp Voltage | $I_{IN} = -18 \text{ mA}$, $V_{CC} = \text{Min.}$ | | -1.5 | V |
| I_{IH} | Input HIGH Current | $V_{IN} = 2.4 \text{ V}$, $V_{CC} = \text{Max.}$ (Note 4) | | 25 | μA |
| I_{IL} | Input LOW Current | $V_{IN} = 0.4 \text{ V}$, $V_{CC} = \text{Max.}$ (Note 4) | | -250 | μA |
| I_I | Maximum Input Current | $V_{IN} = 5.5 \text{ V}$, $V_{CC} = \text{Max.}$ | | 1 | mA |
| I_{ozH} | Off-State Output Leakage Current HIGH | $V_{OUT} = 2.4 \text{ V}$, $V_{CC} = \text{Max.}$ $V_{IN} = V_{IH}$ or V_{IL} (Note 4) | | 100 | μA |
| I_{ozL} | Off-State Output Leakage Current LOW | $V_{OUT} = 0.4 \text{ V}$, $V_{CC} = \text{Max.}$ $V_{IN} = V_{IH}$ or V_{IL} (Note 4) | | -100 | μA |
| I_{SC} | Output Short-Circuit Current | $V_{OUT} = 0.5 \text{ V}$, $V_{CC} = \text{Max.}$ (Note 5) | -30 | -250 | mA |
| I_{CC} | Supply Current | $V_{IN} = 0 \text{ V}$, Outputs Open ($I_{OUT} = 0 \text{ mA}$) $V_{CC} = \text{Max.}$ | | 55 | mA |

Notes:

2. For APL Products, Group A, Subgroups 1, 2, and 3 are tested per MIL-STD-883, Method 5005, unless otherwise noted.
3. V_{IL} and V_{IH} are input conditions of output tests and are not themselves directly tested. V_{IL} and V_{IH} are absolute voltages with respect to device ground and include all overshoots due to system and/or tester noise. Do not attempt to test these values without suitable equipment.
4. I/O pin leakage is the worst case of I_{IL} and I_{ozL} (or I_{IH} and I_{ozH}).
5. Not more than one output should be tested at a time. Duration of the short-circuit should not exceed one second. $V_{OUT} = 0.5 \text{ V}$ has been chosen to avoid test problems caused by tester ground degradation.

SWITCHING CHARACTERISTICS over MILITARY operating ranges (Note 1)

| Parameter Symbol | Parameter Description | | Min. | Max. | Unit | |
|------------------|---|-------------------|--------------------|-----------------------|------|-----|
| t_{PD} | Input or Feedback to Combinatorial Output | | | 50 | ns | |
| t_s | Setup Time from Input or Feedback to Clock | | 50 | | ns | |
| t_H | Hold Time | | 0 | | ns | |
| t_{CO} | Clock to Output or Feedback | | | 25 | ns | |
| t_{WL} | Clock Width | LOW | 16R8, 16R6 16R4 | 25 | ns | |
| t_{WH} | | HIGH | | 25 | ns | |
| f_{MAX} | Maximum Frequency (Note 2) | External Feedback | | $1/(t_s + t_{CO})$ | 13.3 | MHz |
| | | No Feedback | | $1/(t_{WH} + t_{WL})$ | 20 | MHz |
| t_{PXZ} | \overline{OE} to Output Enable (Note 3) | | | | 25 | ns |
| t_{PXZ} | \overline{OE} to Output Disable (Note 3) | | | | 25 | ns |
| t_{EA} | Input to Output Enable Using Product Term Control (Note 3) | | | | 45 | ns |
| t_{ER} | Input to Output Disable Using Product Term Control (Note 3) | | | | 45 | ns |

2

Notes:

1. See Switching Test Circuit for test conditions. For APL products Group A, Subgroups 9, 10, and 11 are tested per MIL-STD-883, Method 5005, unless otherwise noted.
2. These parameters are not 100% tested, but are calculated at initial characterization and at any time the design is modified where frequency may be affected.
3. These parameters are not 100% tested, but are evaluated at initial characterization and at any time the design is modified where these parameters may be affected.

ABSOLUTE MAXIMUM RATINGS

| | |
|--|----------------------------|
| Storage Temperature | -65°C to +150°C |
| Ambient Temperature with Power Applied | -55°C to +125°C |
| Supply Voltage with Respect to Ground | -0.5 V to +7.0 V |
| DC Input Voltage | -1.5 V to $V_{CC} + 0.5$ V |
| DC Output or I/O Pin Voltage | -0.5 V to $V_{CC} + 0.5$ V |

Stresses above those listed under Absolute Maximum Ratings may cause permanent device failure. Functionality at or above these limits is not implied. Exposure to Absolute Maximum Ratings for extended periods may affect device reliability. Programming conditions may differ.

OPERATING RANGES

Commercial (C) Devices

| | |
|--|--------------------|
| Ambient Temperature (T_A) | 0°C to +75°C |
| Operating in Free Air | 0°C to +75°C |
| Supply Voltage (V_{CC}) with Respect to Ground | +4.75 V to +5.25 V |

Operating ranges define those limits between which the functionality of the device is guaranteed.

DC CHARACTERISTICS over COMMERCIAL operating ranges unless otherwise specified

| Parameter Symbol | Parameter Description | Test Conditions | Min. | Max. | Unit |
|------------------|---------------------------------------|--|--|------|---------|
| V_{OH} | Output HIGH Voltage | $I_{OH} = -3.2$ mA, $V_{IN} = V_{IH}$ or V_{IL} , $V_{CC} = \text{Min.}$ | 2.4 | | V |
| V_{OL} | Output LOW Voltage | $I_{OL} = 20$ mA, $V_{IN} = V_{IH}$ or V_{IL} , $V_{CC} = \text{Min.}$ | | 0.5 | V |
| V_{IH} | Input HIGH Voltage | Guaranteed Input Logical HIGH Voltage for all Inputs (Note 1) | 2.0 | | V |
| V_{IL} | Input LOW Voltage | Guaranteed Input Logical LOW Voltage for all Inputs (Note 1) | | 0.8 | V |
| V_I | Input Clamp Voltage | $I_I \leq 18$ mA, $V_{CC} = \text{Min.}$ | | -1.2 | V |
| I_{IH} | Input HIGH Current | $V_{IN} = 2.4$ V, $V_{CC} = \text{Max.}$ (Note 2) | | 25 | μ A |
| I_{IL} | Input LOW Current | $V_{IN} = 0.4$ V, $V_{CC} = \text{Max.}$ (Note 2) | | -250 | μ A |
| I_I | Maximum Input Current | $V_I = 5.5$ V, $V_{CC} = \text{Max.}$ | | 100 | μ A |
| I_{OZH} | Off-State Output Leakage Current HIGH | $V_{OUT} = 2.4$ V, $V_{CC} = \text{Max.}$, $V_{IN} = V_{IH}$ or V_{IL} (Note 2) | | 100 | μ A |
| I_{OZL} | Off-State Output Leakage Current LOW | $V_{OUT} = 0.4$ V, $V_{CC} = \text{Max.}$, $V_{IN} = V_{IH}$ or V_{IL} (Note 2) | | -100 | μ A |
| I_{SC} | Output Short-Circuit Current | $V_{OUT} = 0.5$ V, $V_{CC} = \text{Max.}$ (Note 3) | -30 | -130 | mA |
| I_{CC} | Supply Current | 16L8 | $V_{IN} = 0$ V, Outputs Open ($I_{OUT} = 0$ mA), $V_{CC} = \text{Max.}$ | 80 | mA |
| | | 16R8/6/4 | | 90 | |

Notes:

- These are absolute values with respect to device ground and all overshoots due to system and/or tester noise are included.
- I/O pin leakage is the worst case of I_{IL} and I_{OZL} (or I_{IH} and I_{OZH}).
- Not more than one output should be tested at a time. Duration of the short-circuit should not exceed one second. $V_{OUT} = 0.5$ V as been chosen to avoid test problems caused by tester ground degradation.

CAPACITANCE (Note 1)

| Parameter Symbol | Parameter Descriptions | Test Conditions | | Typ. | Unit |
|------------------|------------------------|--------------------------|---|------|------|
| C _{IN} | Input Capacitance | V _{IN} = 2.0 V | V _{CC} = 5.0 V T _A = 25°C f = 1 MHz | 7 | pF |
| C _{OUT} | Output Capacitance | V _{OUT} = 2.0 V | | 7 | |

Note:

1. These parameters are not 100% tested, but are evaluated at initial characterization and at any time the design is modified where capacitance may be affected.

SWITCHING CHARACTERISTICS over COMMERCIAL operating ranges (Note 2)

| Parameter Symbol | Parameter Description | | Min. | Max. | Unit |
|------------------|--|--|--------------------|------|------|
| t _{PD} | Input or Feedback to Combinatorial Output | | 16L8, 16R8 16R4 | 35 | ns |
| t _S | Setup Time from Input or Feedback to Clock | | | | ns |
| t _H | Hold Time | | | 0 | ns |
| t _{CO} | Clock to Output or Feedback | | 16R8, 16R6 | 25 | ns |
| t _{WL} | Clock Width | LOW | 16R4 | 25 | ns |
| t _{WH} | | HIGH | | 25 | ns |
| f _{MAX} | Maximum Frequency (Note 3) | External Feedback 1/(t _S + t _{CO}) | | 1 | MHz |
| | | No Feedback 1/(t _{WH} + t _{WL}) | | 20 | MHz |
| t _{PZX} | OE to Output Enable | | | 25 | ns |
| t _{PXZ} | OE to Output Disable | | | 25 | ns |
| t _{EA} | Input to Output Enable Using Product Term Control | | 16L8, 16R6 | 35 | ns |
| t _{ER} | Input to Output Disable Using Product Term Control | | 16R4 | 35 | ns |

Notes:

2. See Switching Test Circuit for test conditions.
3. These parameters are not 100% tested, but are calculated at initial characterization and at any time the design is modified where frequency may be affected.

ABSOLUTE MAXIMUM RATINGS

| | |
|--|------------------|
| Storage Temperature | -65°C to +150°C |
| Ambient Temperature with Power Applied | -55°C to +125°C |
| Supply Voltage with Respect to Ground | -0.5 V to +7.0 V |
| DC Input Voltage | -1.5 V to +5.5 V |
| DC Output or I/O Pin Voltage | 5.5 V |

Stresses above those listed under Absolute Maximum Ratings may cause permanent device failure. Functionality at or above these limits is not implied. Exposure to Absolute Maximum Ratings for extended periods may affect device reliability. Programming conditions may differ. Absolute Maximum Ratings are for system design reference; parameters given are not tested.

OPERATING RANGES

Military (M) Devices (Note 1)

| | |
|--|--------------------|
| Ambient Temperature (T _A) | -55°C to +125°C |
| Operating in Free Air | -55°C to +125°C |
| Supply Voltage (V _{CC}) with Respect to Ground | +4.50 V to +5.50 V |

Operating ranges define those limits between which the functionality of the device is guaranteed.

Note:

1. Military products are tested at T_C = +25°C, +125°C, and -55°C, per MIL-STD-883.

DC CHARACTERISTICS over MILITARY operating ranges unless otherwise specified (Note 2)

| Parameter Symbol | Parameter Description | Test Conditions | Min. | Max. | Unit |
|------------------|---------------------------------------|---|------|------|------|
| V _{OH} | Output HIGH Voltage | I _{OH} = 2 mA, V _{IN} = V _{IH} or V _{IL} , V _{CC} = Min. | 2.4 | | V |
| V _{OL} | Output LOW Voltage | I _{OL} = 2 mA, V _{IN} = V _{IH} or V _{IL} , V _{CC} = Min. | | 0.5 | V |
| V _{IH} | Input HIGH Voltage | Guaranteed Logic Level HIGH Voltage for all inputs (Note 3) | 2.0 | | V |
| V _{IL} | Input LOW Voltage | Guaranteed Logic Level LOW Voltage for all inputs (Note 3) | | 0.8 | V |
| V _I | Input Clamp Voltage | I _{IN} = 10 mA, V _{CC} = Min. | | -1.5 | V |
| I _{IH} | Input HIGH Current | V _{IN} = 2.4 V, V _{CC} = Max. (Note 4) | | 25 | μA |
| I _{IL} | Input LOW Current | V _{IN} = 0.4 V, V _{CC} = Max. (Note 4) | | -250 | μA |
| I _I | Maximum Input Current | V _{IN} = 5.5 V, V _{CC} = Max. | | 1 | mA |
| I _{OZH} | Off-State Output Leakage Current HIGH | V _{OUT} = 2.4 V, V _{CC} = Max. V _{IN} = V _{IH} or V _{IL} (Note 4) | | 100 | μA |
| I _{OZL} | Off-State Output Leakage Current LOW | V _{OUT} = 0.4 V, V _{CC} = Max. V _{IN} = V _{IH} or V _{IL} (Note 4) | | -100 | μA |
| I _{SC} | Output Short-Circuit Current | V _{OUT} = 0.5 V, V _{CC} = Max. (Note 5) | -30 | -250 | mA |
| I _{CC} | Supply Current | V _{IN} = 0 V, Outputs Open (I _{OUT} = 0 mA) V _{CC} = Max. | | 90 | mA |

Notes:

2. For APL Products, Group A, Subgroups 1, 2, and 3 are tested per MIL-STD-883, Method 5005, unless otherwise noted.
3. V_{IL} and V_{IH} are input conditions of output tests and are not themselves directly tested. V_{IL} and V_{IH} are absolute voltages with respect to device ground and include all overshoots due to system and/or tester noise. Do not attempt to test these values without suitable equipment.
4. I/O pin leakage is the worst case of I_{IL} and I_{OZL} (or I_{IH} and I_{OZH}).
5. Not more than one output should be tested at a time. Duration of the short-circuit should not exceed one second. V_{OUT} = 0.5 V has been chosen to avoid test problems caused by tester ground degradation.

CAPACITANCE (Note 1)

| Parameter Symbol | Parameter Description | Test Conditions | | Typ. | Unit |
|------------------|-----------------------|--------------------------|--|------|------|
| C _{IN} | Input Capacitance | V _{IN} = 2.0 V | V _{CC} = 5.0 V T _A = 25°C | 7 | pF |
| C _{OUT} | Output Capacitance | V _{OUT} = 2.0 V | f = 1 MHz | 7 | |

Note:

1. These parameters are not 100% tested, but are evaluated at initial characterization and at any time the design is modified where capacitance may be affected.

SWITCHING CHARACTERISTICS over MILITARY operating ranges (Note 2)

| Parameter Symbol | Parameter Description | | Min. | Max. | Unit |
|------------------|---|-------------------|--|------|------|
| t _{PD} | Input or Feedback to Combinatorial Output | | 16L8, 16R6 | 50 | ns |
| t _S | Setup Time from Input or Feedback to Clock | | | 50 | ns |
| t _H | Hold Time | | | 0 | ns |
| t _{CO} | Clock to Output or Feedback | | | 25 | ns |
| t _{WL} | Clock Width | LOW | 16R8, 16R6 16R4 | 25 | ns |
| t _{WH} | | HIGH | | 2 | ns |
| f _{MAX} | Maximum Frequency (Note 3) | External Feedback | 1/(t _S + t _{CO}) | 100 | MHz |
| | | No Feedback | 1/(t _{WH} + t _{WL}) | 20 | MHz |
| t _{PZX} | OE to Output Enable (Note 4) | | | 25 | ns |
| t _{PNZ} | OE to Output Disable (Note 4) | | | 25 | ns |
| t _{EA} | Input to Output Enable Using Product Term Control (Note 4) | | 16L8, 16R6 16R4 | 45 | ns |
| t _{ER} | Input to Output Disable Using Product Term Control (Note 4) | | | 45 | ns |

Notes:

2. See Switching Test Circuit for test conditions. For APL products Group A, Subgroups 9, 10, and 11 are tested per MIL-STD-883, Method 5005, unless otherwise noted.
3. These parameters are not 100% tested, but are calculated at initial characterization and at any time the design is modified where frequency may be affected.
4. These parameters are not 100% tested, but are evaluated at initial characterization and at any time the design is modified where these parameters may be affected.

SWITCHING WAVEFORMS

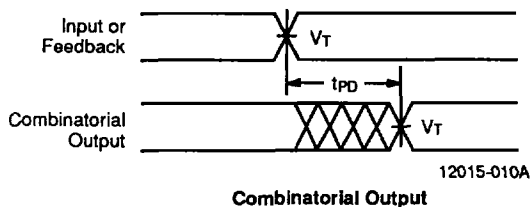

Combinatorial Output

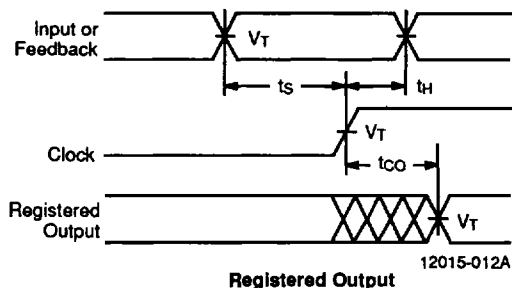

Registered Output

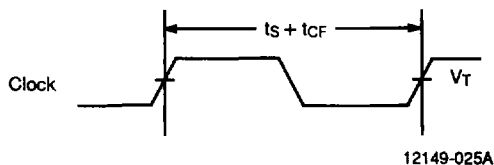

Clock to Feedback (t_{MAX} Internal)
See Path at Right

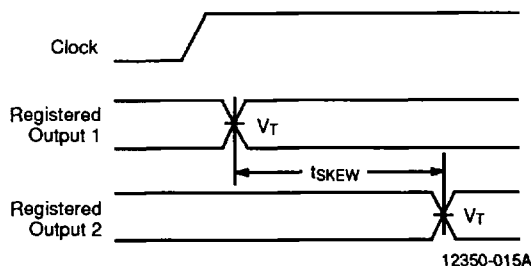
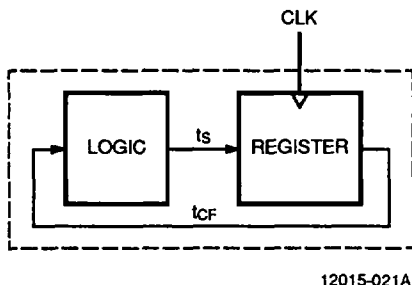

Registered Output Skew for Outputs
Switching in the Same Direction

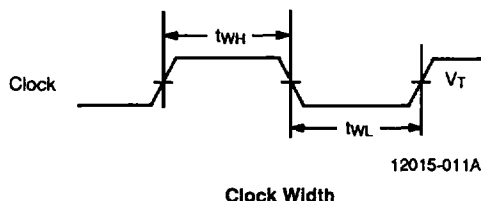

Clock Width

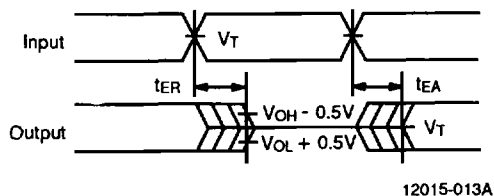

Input to Output Disable/Enable

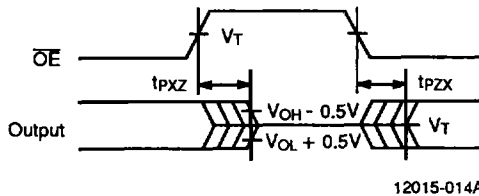





\overline{OE} to Output Disable/Enable

Notes:

1. $V_T = 1.5$ V
2. Input pulse amplitude 0 V to 3.0 V
3. Input rise and fall times 2–5 ns typical.
(2–4 ns for -7 (-12 Mil) Series)

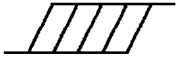
KEY TO SWITCHING WAVEFORMS

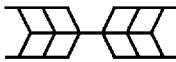
| WAVEFORM | INPUTS | OUTPUTS |
|---|----------------------------------|---|
|  | Must be Steady | Will be Steady |
|  | May Change from H to L | Will be Changing from H to L |
|  | May Change from L to H | Will be Changing from L to H |
|  | Don't Care; Any Change Permitted | Changing, State Unknown |
|  | Does Not Apply | Center Line is High-Impedance "Off" State |

KS000010-PAL

2

SWITCHING TEST CIRCUIT

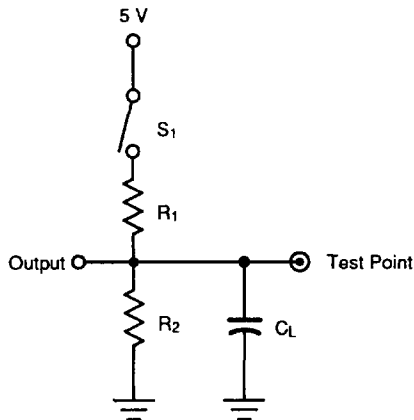

12350-019A

| Specification | S ₁ | C _L | Commercial | | Military | | Measured Output Value |
|---|------------------------------|----------------|----------------|-----------------|----------------|-----------------|--|
| | | | R ₁ | R ₂ | R ₁ | R ₂ | |
| t _{PD} , t _{CO} , t _{CF} | Closed | 50 pF | | | | | 1.5 V |
| t _{PZX} , t _{EA} | Z → H: Open Z → L: Closed | | 200 Ω | 390 Ω | 390 Ω | 750 Ω | 1.5 V |
| t _{PXZ} , t _{ER} | H → Z: Open L → Z: Closed | 5 pF | B-4: 800 Ω | B-4: 1.56 KΩ | B-4: 800 Ω | B-4: 1.56 KΩ | H → Z: V _{OH} - 0.5 V L → Z: V _{OL} + 0.5 V |

INPUT/OUTPUT EQUIVALENT SCHEMATICS

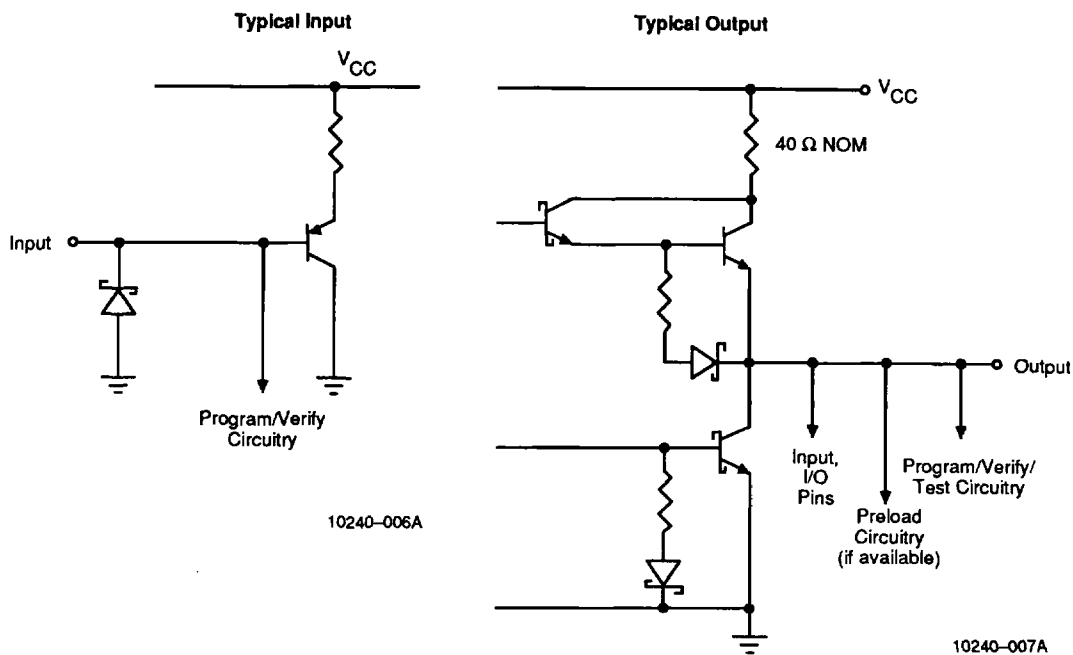

OUTPUT REGISTER PRELOAD

Applies to -7 (-12 Mil) Series Only

The preload function allows the register to be loaded from the output pins. This feature aids functional testing of sequential designs by allowing direct setting of output states. The procedure for preloading follows.

1. Raise V_{CC} to V_{CCH} .
2. Set \overline{OE} to V_{IHP} to disable output registers.
3. Raise pin 2 to V_{HH} to enter preload mode.
4. Apply either V_{HH} or V_{ILP} to all registered outputs. Use V_{HH} to preload a HIGH in the flip-flop; use V_{ILP} to preload a LOW in the flip-flop. Leave combinatorial outputs floating.
5. Lower pin 2 to V_{ILP} .
6. Remove V_{ILP}/V_{HH} from all registered output pins.
7. Lower \overline{OE} to V_{ILP} to enable the output registers.
8. Verify V_{OL}/V_{OH} at all registered output pins. Note that because of the output inverter, a register that has been preloaded HIGH will provide a LOW at the output.

| Parameter Symbol | Parameter Description | Min. | Rec. | Max. | Unit |
|------------------|-----------------------------|------|------|------|------|
| V_{HH} | Super-level input voltage | 10 | 11 | 12 | V |
| V_{ILP} | Low-level input voltage | 0 | 0 | 0.5 | V |
| V_{IHP} | High-level input voltage | 2.4 | 5.0 | 5.5 | V |
| V_{CCH} | Power supply during preload | 5.4 | 5.7 | 6.0 | V |
| t_D | Delay time | 100 | 200 | 1000 | ns |

2

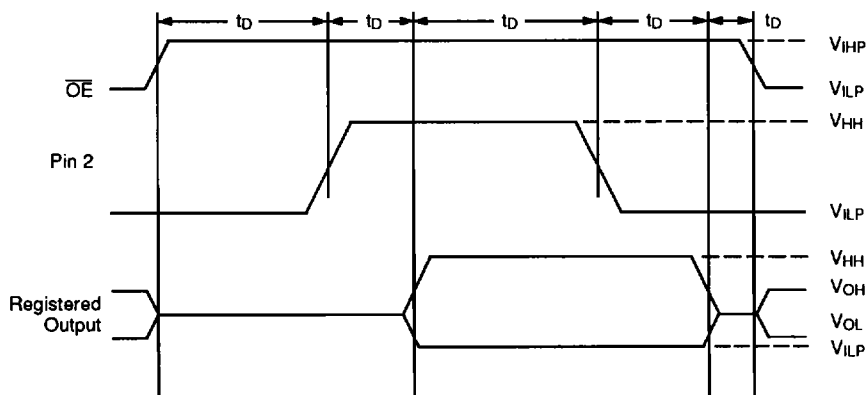

10294-003A

Output Register Preload Waveform

OUTPUT REGISTER PRELOAD

Applies to H-15 Series Only

The preload function allows the register to be loaded from the output pins. This feature aids functional testing of sequential designs by allowing direct setting of output states. The procedure for preloading follows.

1. Raise V_{CC} to 4.5 V.
2. Set \overline{OE} to V_{IHP} to disable output registers.
3. Apply either V_{IHP} or V_{ILP} to all registered outputs. Use V_{IHP} to preload a HIGH in the flip-flop; use V_{ILP} to preload a LOW in the flip-flop. Leave combinatorial outputs floating.
4. Pulse pin 8 to V_{HH} , then back to 0 V.
5. Remove V_{ILP}/V_{IHP} from all registered output pins.
6. Lower \overline{OE} to V_{ILP} to enable the output registers.
7. Verify V_{OL}/V_{OH} at all registered output pins. Note that because of the output inverter, a register that has been preloaded HIGH will provide a LOW at the output.

| Parameter Symbol | Parameter Description | Min. | Rec. | Max. | Unit |
|------------------|---------------------------|------|------|------|------|
| V_{HH} | Super-level input voltage | 19 | 20 | 21 | V |
| V_{ILP} | Low-level input voltage | 0 | 0 | 0.5 | V |
| V_{IHP} | High-level input voltage | 2.4 | 5.0 | 5.5 | V |
| t_D | Delay time | 100 | 200 | 1000 | ns |

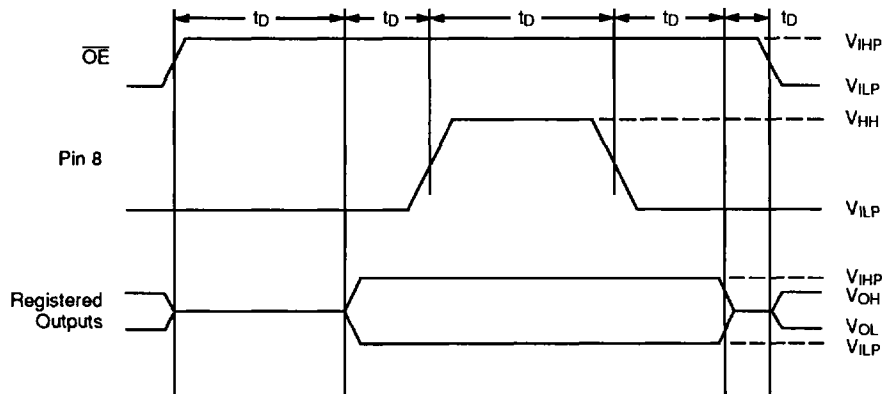

10240-008A

Output Register Preload Waveform

POWER-UP RESET

Applies to -7 (-12 Mil), H-15, B, B-2, A, A-2 Series Only

The power-up reset feature ensures that all flip-flops will be reset to LOW after the device has been powered up. The output state will be HIGH due to the inverting output buffer. This feature is valuable in simplifying state machine initialization. A timing diagram and parameter table are shown below. Due to the synchronous operation

of the power-up reset and the wide range of ways V_{CC} can rise to its steady state, two conditions are required to ensure a valid power-up reset. These conditions are:

1. The V_{CC} rise must be monotonic.
2. Following reset, the clock input must not be driven from LOW to HIGH until all applicable input and feedback setup times are met.

| Parameter Symbol | Parameter Description | Max. | Unit |
|------------------|------------------------------|-------------------------------|------|
| t_{PR} | Power-up Reset Time | 1000 | ns |
| t_s | Input or Feedback Setup Time | See Switching Characteristics | |
| t_{WL} | Clock Width LOW | See Switching Characteristics | |

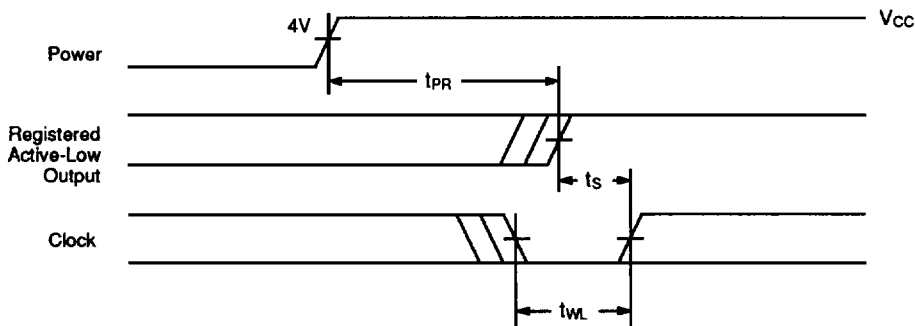

12350-024A

Power-Up Reset Waveform

2