

IS41LV32256



256K x 32 (8-Mbit) EDO DYNAMIC RAM 3.3V, 100/83/66 MHz

ADVANCE INFORMATION
APRIL 1998

FEATURES

- 262,144-word by 32-bit organization
- Single +3.3V \pm 0.3V power supply
- Four $\overline{\text{CAS}}$ inputs for Byte Write and Byte Read control
- Refresh modes: $\overline{\text{RAS}}$ -Only, $\overline{\text{CAS}}$ -Before- $\overline{\text{RAS}}$ (CBR), and Hidden
- 512-cycle refresh in 8 ms
- Fast Page Mode with Extended Data Out
- 100-pin PQFP, TQFP package

DESCRIPTION

The *ISSI* IS41LV32256 is organized in a 262,122 x 32-bit CMOS Dynamic Random Access Memory. Four $\overline{\text{CAS}}$ signals facilitate execution of Byte Read and Byte Write operations. A very fast EDO cycle time of 10 ns allows an operating frequency of 100 MHz and makes the IS41LV32256 an ideal frame buffer memory for graphics applications.

The IS41LV32256 is compatible with JEDEC standard SGRAMs. This 8Mb EDO memory offers a significantly lower latency and a faster memory cycle than the SGRAM. *ISSI's* IS41LV32256 3.3V 256K x 32 device is pin/voltage compatible with all standard SGRAM parts.

The IS41LV32256 is available in a 100-pin PQFP, TQFP package.

KEY TIMING PARAMETERS

Parameter	-25	-28	-35	Unit
Max. $\overline{\text{RAS}}$ Access Time (t_{RAC})	25	28	35	ns
Max. $\overline{\text{CAS}}$ Access Time (t_{CAC})	8	9	10	ns
Max. Column Address Access Time (t_{AA})	12	15	18	ns
Max. $\overline{\text{OE}}$ Access Time (t_{OE})	8	9	10	ns
Min. Read/Write Cycle Time (t_{RC})	45	48	60	ns
Min. EDO Cycle Time (t_{PC})	10	12	15	ns
EDO Cycle Time	100	83	66	MHz

This document contains ADVANCE INFORMATION data. ISSI reserves the right to make changes to its products at any time without notice in order to improve design and supply the best possible product. We assume no responsibility for any errors which may appear in this publication. © Copyright 1998, Integrated Silicon Solution, Inc.

FUNCTIONAL BLOCK DIAGRAM

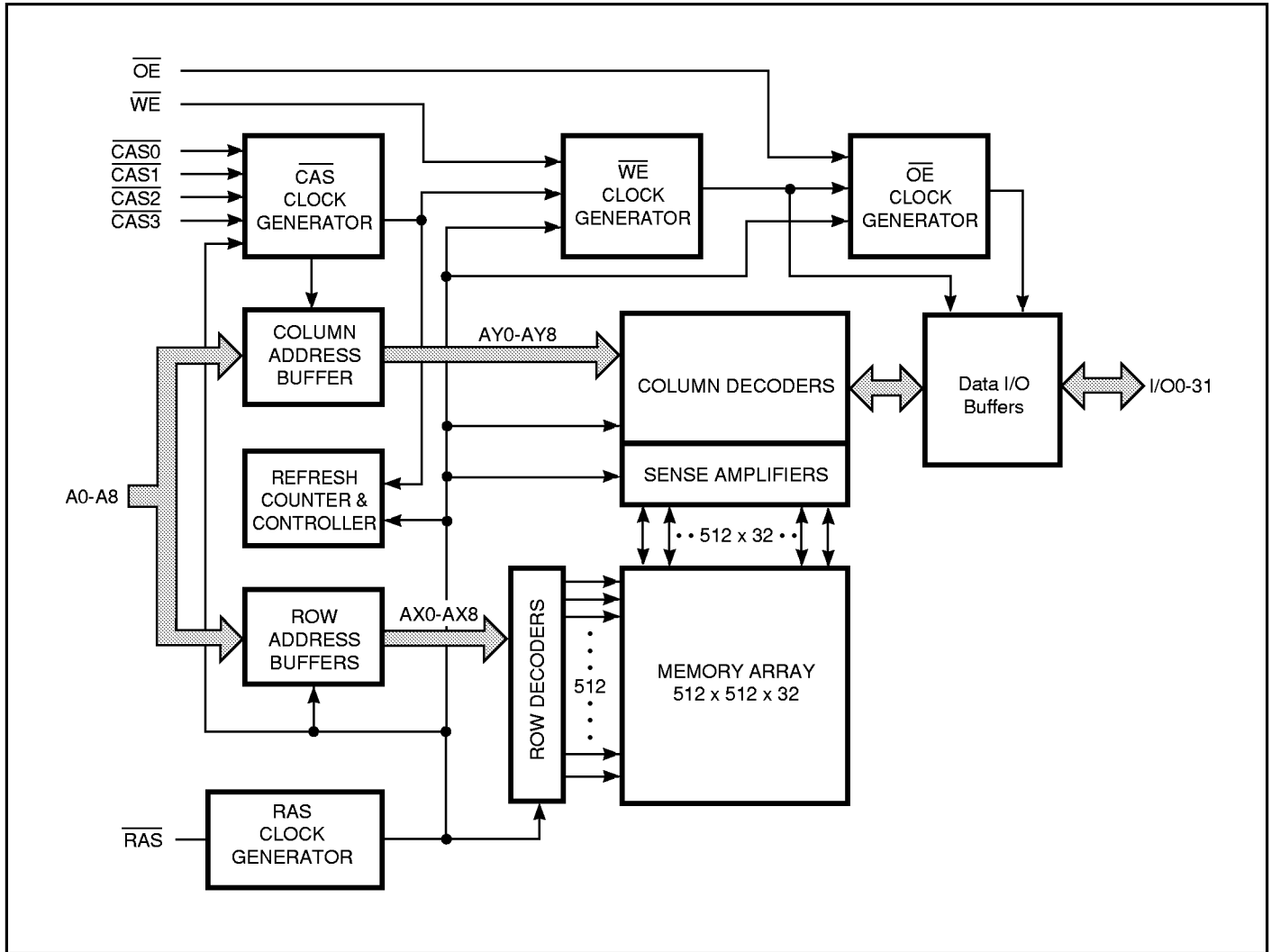

PIN CONFIGURATIONS

100-Pin PQFP, TQFP

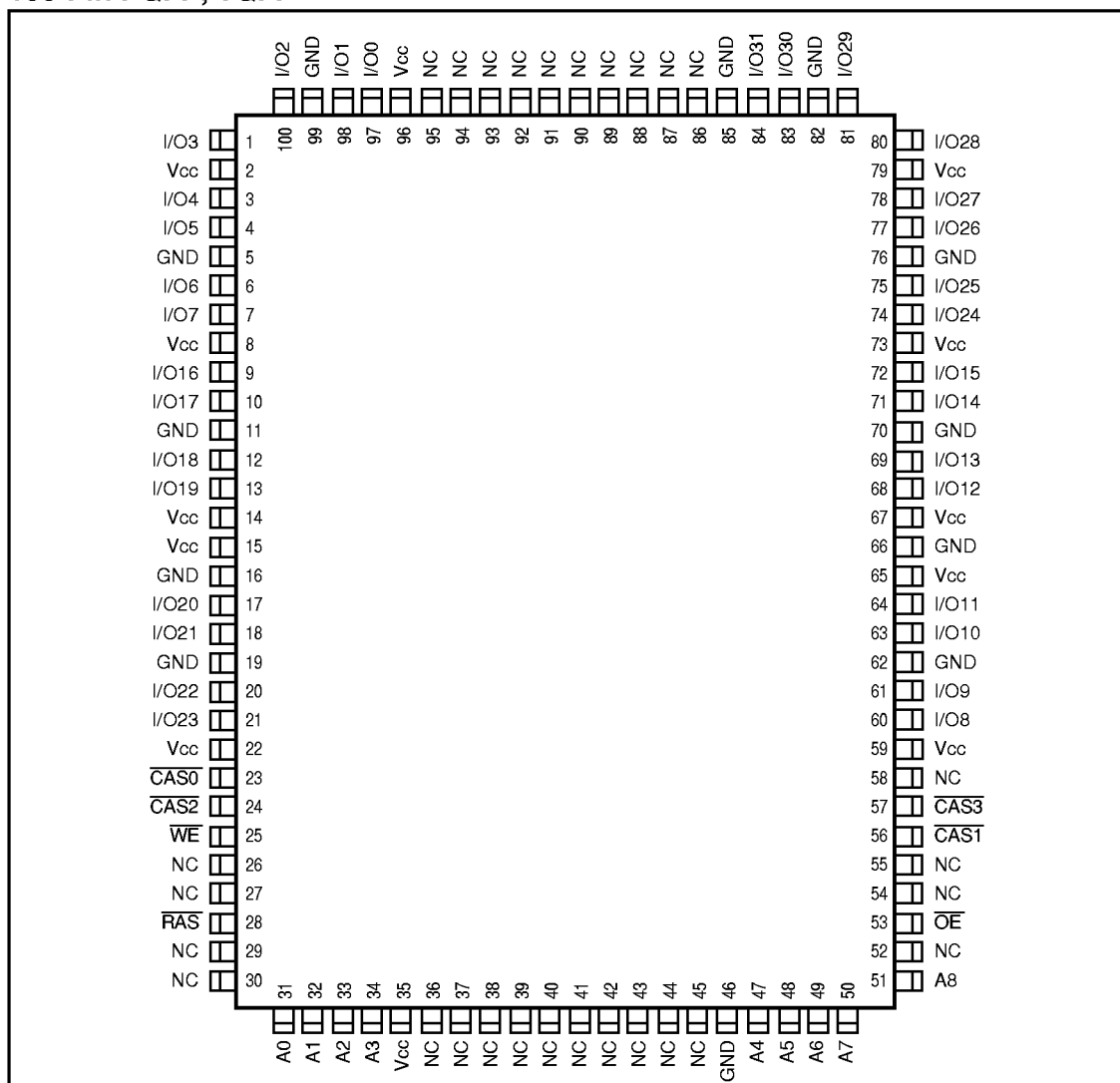

PIN DESCRIPTIONS

A0-A8	Address Inputs
$\overline{\text{RAS}}$	Row Address Strobe
$\overline{\text{CAS0}}$	Column Address Strobe for First Byte (I/O0-I/O7)
$\overline{\text{CAS1}}$	Column Address Strobe for Second Byte (I/O8-I/O15)
$\overline{\text{CAS2}}$	Column Address Strobe for Third Byte (I/O16-I/O23)
$\overline{\text{CAS3}}$	Column Address Strobe for Fourth Byte (I/O24-I/O31)
$\overline{\text{WE}}$	Write Enable
$\overline{\text{OE}}$	Output Enable
I/O0-I/O31	Data Inputs/Outputs
Vcc	+3.3V Supply
GND	Ground
NC	No Connection: This pin should be left unconnected or tied to ground.

TRUTH TABLE

Function	$\overline{\text{RAS}}$	$\overline{\text{CAS0}}$	$\overline{\text{CAS1}}$	$\overline{\text{CAS2}}$	$\overline{\text{CAS3}}$	$\overline{\text{WE}}$	$\overline{\text{OE}}$	Address	I/O
Standby	H	H	H	H	H	X	X	X	High-Z
Read: Double Word	L	L	L	L	L	H	L	ROW/COL	D _{OUT}
Read: 1st Byte	L	L	H	H	H	H	L	ROW/COL	I/O0-7=D _{OUT} ; I/O8-31=High-Z
Read: 2nd Byte	L	H	L	H	H	H	L	ROW/COL	I/O0-7=High-Z; I/O8-15=D _{OUT} ; I/O16-31=High-Z
Read: 3rd Byte	L	H	H	L	H	H	L	ROW/COL	I/O0-15=High-Z; I/O16-23=D _{OUT} ; I/O24-31=High-Z
Read: 4th Byte	L	H	H	H	L	H	L	ROW/COL	I/O0-23=High-Z; I/O24-31=D _{OUT}
Write: Double Word (Early)	L	L	L	L	L	L	X	ROW/COL	D _{IN}
Write: 1st Byte (Early)	L	L	H	H	H	L	X	ROW/COL	I/O0-7=D _{IN} ; I/O8-31=X
Write: 2nd Byte (Early)	L	H	L	H	H	L	X	ROW/COL	I/O0-8=X; I/O8-15=D _{IN} ; I/O16-31=X
Write: 3rd Byte (Early)	L	H	H	L	H	L	X	ROW/COL	I/O0-15=X; I/O16-23=D _{IN} ; I/O24-31=X
Write: 4th Byte (Early)	L	H	H	H	L	L	X	ROW/COL	I/O0-23=X; I/O24-31=D _{IN}
Read-Write ^(1,2)	L	L	L	L	L	H→L	L→H	ROW/COL	D _{OUT} →D _{IN}
Fast-Page-Mode Read: EDO ⁽²⁾ 1st Cycle:	L	H→L	H→L	H→L	H→L	H	L	ROW/COL	D _{OUT}
Subsequent Cycles:	L	H→L	H→L	H→L	H→L	H	L	COL	D _{OUT}
Fast-Page-Mode Read: High-Z ⁽²⁾ 1st Cycle:	L	H→L	H→L	H→L	H→L	H	H→L	ROW/COL	D _{OUT}
Subsequent Cycles:	L	H→L	H→L	H→L	H→L	H	H→L	COL	D _{OUT}
Fast-Page-Mode Write: (Early) ⁽¹⁾ 1st Cycle:	L	H→L	H→L	H→L	H→L	L	X	ROW/COL	D _{IN}
Subsequent Cycles:	L	H→L	H→L	H→L	H→L	L	X	COL	D _{IN}
Fast-Page-Mode Read-Write ^(1,2) 1st Cycle:	L	H→L	H→L	H→L	H→L	H→L	L→H	ROW/COL	D _{OUT} →D _{IN}
Subsequent Cycles:	L	H→L	H→L	H→L	H→L	H→L	L→H	COL	D _{OUT} →D _{IN}
Hidden Refresh Read ⁽²⁾	L→H→L	L	L	L	L	H	L	ROW/COL	D _{OUT}
Hidden Refresh Write ⁽¹⁾	L→H→L	L	L	L	L	L	X	ROW/COL	D _{IN} →High-Z
$\overline{\text{RAS}}$ -Only Refresh	L	H	H	H	H	X	X	ROW	High-Z
CBR Refresh ⁽³⁾	H→L	L	L	L	L	X	X	X	High-Z

Notes:

1. BYTE WRITE may be executed with $\overline{\text{CAS0}}$, $\overline{\text{CAS1}}$, $\overline{\text{CAS2}}$ or $\overline{\text{CAS3}}$ active.
2. BYTE READ may be executed with $\overline{\text{CAS0}}$, $\overline{\text{CAS1}}$, $\overline{\text{CAS2}}$ or $\overline{\text{CAS3}}$ active.
3. Only one $\overline{\text{CAS}}$ signal ($\overline{\text{CAS0}}$, $\overline{\text{CAS1}}$, $\overline{\text{CAS2}}$ or $\overline{\text{CAS3}}$) must be active.

Power-On

The initial application of the V_{CC} supply requires a 200- μ s wait followed by a minimum of any eight initialization cycles containing a RAS clock. During Power-On, the V_{CC} current is dependent on the input levels of RAS and CAS. It is recommended that RAS and CAS track with V_{CC} or be held at a valid V_{IH} during Power-On to avoid current surges.

ABSOLUTE MAXIMUM RATINGS⁽¹⁾

Symbol	Parameters	Rating	Unit
t_A	Ambient Temperature Under Bias	-1.0 to +80	°C
t_{STG}	Storage Temperature	-50 to +125	°C
V_T	Voltage Relative to GND	-1.0 to +5.5	V
I_{OUT}	Data Output Current	50	mA
P_D	Power Dissipation	1.0	W

Note:

1. Stress greater than those listed under ABSOLUTE MAXIMUM RATINGS may cause permanent damage to the device. This is a stress rating only and functional operation of the device at these or any other conditions above those indicated in the operational sections of this specification is not implied. Exposure to absolute maximum rating conditions for extended periods may affect reliability.

RECOMMENDED OPERATING CONDITIONS⁽¹⁾

($T_A = 0^\circ\text{C}$ to 70°C)

Symbol	Parameter	Min.	Typ.	Max.	Unit
V_{CC}	Power Supply	3.0	3.3	3.6	V
V_{IH}	Input High Voltage	2.4	—	$V_{CC} + 0.5$	V
V_{IL}	Input Low Voltage	-0.5	—	0.4	V

Note:

1. Voltages are referenced to GND.

CAPACITANCE^(1,2)

Symbol	Parameter	Max.	Unit
C_{IN}	Input Capacitance	5	pF
C_{IO}	Data Input/Output Capacitance	7	pF

Notes:

1. Capacitance is sampled and 100% tested.
2. Test conditions: $T_A = 25^\circ\text{C}$, $f = 1\text{ MHz}$, $V_{CC} = 3.3\text{V}$.

DC CHARACTERISTICS(T_A = 0°C to 70°C, V_{CC} = 3.3V ± 0.3V)

Symbol	Parameter	Condition	-25		-28		-35		Units
			Min.	Max.	Min.	Max.	Min.	Max.	
V _{IH}	Input HIGH (Logic 1) Voltage, All Inputs	—	2.0	V _{CC} + 0.5	2.0	V _{CC} + 0.5	2.0	V _{CC} + 0.5	V
V _{IL}	Input LOW (Logic 1) Voltage, All Inputs	—	-0.5	0.8	-0.5	0.8	-0.5	0.8	V
V _{OH}	Output HIGH Voltage	I _{OH} = -2 mA	2.4	V _{CC}	2.4	V _{CC}	2.4	V _{CC}	V
V _{OL}	Output LOW Voltage	I _{OL} = 2 mA	0	0.4	0	0.4	0	0.4	V
I _{LI}	Input Leakage Current	0V < V _{IN} < V _{CC}	-10	10	-10	10	-10	10	μA
I _{LO}	Output Leakage Current	0V < V _{OUT} < 3.6V; Output Disable	-10	10	-10	10	-10	10	μA
I _{CC1}	Average Power Supply Current (Operating) ^(2,3,15,16)	$\overline{\text{RAS}}$, $\overline{\text{CAS}}$ Cycling; t _{RC} = Min.	—	260	—	250	—	240	mA
I _{CC2}	Power Supply Current (Standby)	$\overline{\text{RAS}}$, $\overline{\text{CAS}}$ = V _{IH}	—	2	—	2	—	2	mA
I _{CC3}	Average Power Supply Current ($\overline{\text{RAS}}$ -Only Refresh) ^(2,3,15,16)	$\overline{\text{RAS}}$ = Cycling; $\overline{\text{CAS}}$ = V _{IH} ; t _{RC} = Min.	—	260	—	250	—	240	mA
I _{CC4}	Average Power Supply Current (Fast Page Mode) ^(2,3,15,18)	$\overline{\text{RAS}}$ = V _{IL} ; $\overline{\text{CAS}}$ = Cycling; t _{PC} = Min.	—	240	—	230	—	220	mA
I _{CC5}	Average Power Supply Current ($\overline{\text{CAS}}$ -before- $\overline{\text{RAS}}$ Refresh) ^(2,3,15,16)	$\overline{\text{RAS}}$ = Cycling; $\overline{\text{CAS}}$ -before- $\overline{\text{RAS}}$	—	260	—	250	—	240	mA

AC CHARACTERISTICS^(1,2,3,4,5,6)

(Recommended Operating Conditions unless otherwise noted.)

Symbol	Parameter	-25		-28		-35		Units
		Min.	Max.	Min.	Max.	Min.	Max.	
t _{RC}	Random READ or WRITE Cycle Time	45	—	48	—	60	—	ns
t _{RAC}	Access Time from $\overline{\text{RAS}}$ ^(6, 7)	—	25	—	28	—	35	ns
t _{CAC}	Access Time from $\overline{\text{CAS}}$ ^(6, 8, 15)	—	8	—	9	—	10	ns
t _{AA}	Access Time from Column-Address ⁽⁶⁾	—	12	—	15	—	18	ns
t _{RAS}	$\overline{\text{RAS}}$ Pulse Width	25	10K	28	10K	35	10K	ns
t _{RP}	$\overline{\text{RAS}}$ Precharge Time	15	—	17	—	20	—	ns
t _{CAS}	$\overline{\text{CAS}}$ Pulse Width ⁽²⁶⁾	4	10K	5	10K	6	10K	ns
t _{CP}	$\overline{\text{CAS}}$ Precharge Time ^(9, 25)	4	—	5	—	5	—	ns
t _{CSH}	$\overline{\text{CAS}}$ Hold Time ⁽²¹⁾	25	—	28	—	35	—	ns
t _{RCD}	$\overline{\text{RAS}}$ to $\overline{\text{CAS}}$ Delay Time ^(10, 20)	10	17	10	19	11	28	ns
t _{ASR}	Row-Address Setup Time	0	—	0	—	0	—	ns
t _{RAH}	Row-Address Hold Time	6	—	6	—	6	—	ns
t _{ASC}	Column-Address Setup Time ⁽²⁰⁾	0	—	0	—	0	—	ns
t _{CAH}	Column-Address Hold Time ⁽²⁰⁾	5	—	5	—	6	—	ns
t _{AR}	Column-Address Hold Time (referenced to $\overline{\text{RAS}}$)	19	—	21	—	30	—	ns
t _{RAD}	$\overline{\text{RAS}}$ to Column-Address Delay Time ⁽¹¹⁾	8	13	8	13	10	20	ns
t _{RAL}	Column-Address to $\overline{\text{RAS}}$ Lead Time	12	—	15	—	18	—	ns
t _{RPC}	$\overline{\text{RAS}}$ to $\overline{\text{CAS}}$ Precharge Time	0	—	0	—	0	—	ns
t _{RSH}	$\overline{\text{RAS}}$ Hold Time ⁽²⁷⁾	7	—	7	—	8	—	ns

AC CHARACTERISTICS (Continued)^(1,2,3,4,5,6)

(Recommended Operating Conditions unless otherwise noted.)

Symbol	Parameter	-25		-28		-35		Units
		Min.	Max.	Min.	Max.	Min.	Max.	
tCLZ	$\overline{\text{CAS}}$ to Output in Low-Z ^(15, 29)	3	—	3	—	3	—	ns
tCRP	$\overline{\text{CAS}}$ to RAS Precharge Time ⁽²¹⁾	5	—	5	—	5	—	ns
tOD	Output Disable Time ^(19, 28, 29)	3	15	3	15	3	15	ns
tOE	Output Enable Time ^(15, 16)	—	8	—	9	—	10	ns
tOEHC	$\overline{\text{OE}}$ HIGH Hold Time from $\overline{\text{CAS}}$ HIGH	10	—	10	—	10	—	ns
tOEP	$\overline{\text{OE}}$ HIGH Pulse Width	10	—	10	—	10	—	ns
tOES	$\overline{\text{OE}}$ LOW to $\overline{\text{CAS}}$ HIGH Setup Time	5	—	5	—	5	—	ns
tRCS	Read Command Setup Time ^(17, 20)	0	—	0	—	0	—	ns
tRRH	Read Command Hold Time (referenced to $\overline{\text{RAS}}$) ⁽¹²⁾	0	—	0	—	0	—	ns
tRCH	Read Command Hold Time (referenced to $\overline{\text{CAS}}$) ^(12, 17, 21)	0	—	0	—	0	—	ns
twCH	Write Command Hold Time ^(17, 27)	5	—	5	—	5	—	ns
twCR	Write Command Hold Time (referenced to $\overline{\text{RAS}}$) ⁽¹⁷⁾	19	—	21	—	24	—	ns
twP	Write Command Pulse Width ⁽¹⁷⁾	5	—	5	—	5	—	ns
twPZ	$\overline{\text{WE}}$ Pulse Widths to Disable Outputs	10	—	10	—	10	—	ns
trWL	Write Command to $\overline{\text{RAS}}$ Lead Time ⁽¹⁷⁾	7	—	7	—	8	—	ns
tcWL	Write Command to $\overline{\text{CAS}}$ Lead Time ^(17, 21)	5	—	5	—	8	—	ns
twCS	Write Command Setup Time ^(14, 17, 20)	0	—	0	—	0	—	ns
tDHR	Data-in Hold Time (referenced to $\overline{\text{RAS}}$)	19	—	21	—	24	—	ns
tACH	Column-Address Setup Time to $\overline{\text{CAS}}$ Precharge during WRITE Cycle	15	—	15	—	15	—	ns
tOEH	$\overline{\text{OE}}$ Hold Time from $\overline{\text{WE}}$ during READ-MODIFY-WRITE cycle ⁽¹⁸⁾	5	—	5	—	8	—	ns
tDS	Data-In Setup Time ^(15, 22)	0	—	0	—	0	—	ns
tDH	Data-In Hold Time ^(15, 22)	5	—	5	—	6	—	ns
trWC	READ-MODIFY-WRITE Cycle Time	65	—	70	—	80	—	ns
trWD	$\overline{\text{RAS}}$ to $\overline{\text{WE}}$ Delay Time during READ-MODIFY-WRITE Cycle ⁽¹⁴⁾	35	—	40	—	45	—	ns
tcWD	$\overline{\text{CAS}}$ to $\overline{\text{WE}}$ Delay Time ^(14, 20)	17	—	18	—	25	—	ns
tAWD	Column-Address to $\overline{\text{WE}}$ Delay Time ⁽¹⁴⁾	21	—	24	—	30	—	ns
tPC	EDO Page Mode READ or WRITE Cycle Time ⁽²⁴⁾	10	—	12	—	15	—	ns
trASP	$\overline{\text{RAS}}$ Pulse Width in EDO Page Mode	25	100K	28	100K	35	100K	ns
tCPA	Access Time from $\overline{\text{CAS}}$ Precharge ⁽¹⁵⁾	—	14	—	17	—	21	ns
tPRWC	EDO Page Mode READ-WRITE Cycle Time ⁽²⁴⁾	32	—	34	—	40	—	ns
tCOH	Data Output Hold after $\overline{\text{CAS}}$ LOW	3	—	3	—	3	—	ns
tOFF	Output Buffer Turn-Off Delay from $\overline{\text{CAS}}$ or $\overline{\text{RAS}}$ ^(13, 15, 19, 29)	3	15	3	15	3	15	ns
twHZ	Output Disable Delay from $\overline{\text{WE}}$	3	15	3	15	3	15	ns

AC CHARACTERISTICS (Continued)^(1,2,3,4,5,6)

(Recommended Operating Conditions unless otherwise noted.)

Symbol	Parameter	-25		-28		-35		Units
		Min.	Max.	Min.	Max.	Min.	Max.	
t _{CLCH}	Last $\overline{\text{CAS}}$ going LOW to First $\overline{\text{CAS}}$ returning HIGH ⁽²³⁾	10	—	10	—	10	—	ns
t _{CSR}	$\overline{\text{CAS}}$ Setup Time (CBR REFRESH) ^(30, 20)	5	—	5	—	8	—	ns
t _{CHR}	$\overline{\text{CAS}}$ Hold Time (CBR REFRESH) ^(30, 21)	7	—	7	—	8	—	ns
t _{ORD}	$\overline{\text{OE}}$ Setup Time prior to $\overline{\text{RAS}}$ during HIDDEN REFRESH Cycle	0	—	0	—	0	—	ns
t _{REF}	Refresh Period (512 Cycles)	—	8	—	8	—	8	ns
t _r	Transition Time (Rise or Fall) ^(2, 3)	1	50	1	50	1	50	ns

Notes:

- An initial pause of 200 μs is required after power-up followed by eight $\overline{\text{RAS}}$ refresh cycle ($\overline{\text{RAS}}$ -Only or CBR) before proper device operation is assured. The eight $\overline{\text{RAS}}$ cycles wake-up should be repeated any time the t_{REF} refresh requirement is exceeded.
- V_{IH} (MIN) and V_{IL} (MAX) are reference levels for measuring timing of input signals. Transition times, are measured between V_{IH} and V_{IL} (or between V_{IL} and V_{IH}) and assume to be 1 ns for all inputs.
- In addition to meeting the transition rate specification, all input signals must transit between V_{IH} and V_{IL} (or between V_{IL} and V_{IH}) in a monotonic manner.
- If $\overline{\text{CAS}}$ and $\overline{\text{RAS}} = \text{V}_{\text{IH}}$, data output is High-Z.
- If $\overline{\text{CAS}} = \text{V}_{\text{IL}}$, data output may contain data from the last valid READ cycle.
- Measured with a load equivalent to one TTL gate and 50 pF.
- Assumes that t_{RCD} ≤ t_{RCD} (MAX). If t_{RCD} is greater than the maximum recommended value shown in this table, t_{RAC} will increase by the amount that t_{RCD} exceeds the value shown.
- Assumes that t_{RCD} ≥ t_{RCD} (MAX).
- If $\overline{\text{CAS}}$ is LOW at the falling edge of $\overline{\text{RAS}}$, data out will be maintained from the previous cycle. To initiate a new cycle and clear the data output buffer, $\overline{\text{CAS}}$ and $\overline{\text{RAS}}$ must be pulsed for t_{CP}.
- Operation with the t_{RCD} (MAX) limit ensures that t_{RAC} (MAX) can be met. t_{RCD} (MAX) is specified as a reference point only; if t_{RCD} is greater than the specified t_{RCD} (MAX) limit, access time is controlled exclusively by t_{CAC}.
- Operation within the t_{RAD} (MAX) limit ensures that t_{RCD} (MAX) can be met. t_{RAD} (MAX) is specified as a reference point only; if t_{RAD} is greater than the specified t_{RAD} (MAX) limit, access time is controlled exclusively by t_{AA}.
- Either t_{RCH} or t_{RRH} must be satisfied for a READ cycle.
- t_{OFF} (MAX) defines the time at which the output achieves the open circuit condition; it is not a reference to V_{OH} or V_{OL}.
- t_{WCS}, t_{RWD}, t_{AWD} and t_{CWD} are restrictive operating parameters in LATE WRITE and READ-MODIFY-WRITE cycle only. If t_{WCS} ≥ t_{WCS} (MIN), the cycle is an EARLY WRITE cycle and the data output will remain open circuit throughout the entire cycle. If t_{RWD} ≥ t_{RWD} (MIN), t_{AWD} ≥ t_{AWD} (MIN) and t_{CWD} ≥ t_{CWD} (MIN), the cycle is a READ-WRITE cycle and the data output will contain data read from the selected cell. If neither of the above conditions is met, the state of I/O (at access time and until $\overline{\text{CAS}}$ and $\overline{\text{RAS}}$ or $\overline{\text{OE}}$ go back to V_{IH}) is indeterminate. $\overline{\text{OE}}$ held HIGH and $\overline{\text{WE}}$ taken LOW after $\overline{\text{CAS}}$ goes LOW result in a LATE WRITE ($\overline{\text{OE}}$ -controlled) cycle.
- Output parameter (I/O) is referenced to corresponding $\overline{\text{CAS}}$ input, I/O0-I/O7 by $\overline{\text{LCAS}}$ and I/O8-I/O15 by $\overline{\text{UCAS}}$.
- During a READ cycle, if $\overline{\text{OE}}$ is LOW then taken HIGH before $\overline{\text{CAS}}$ goes HIGH, I/O goes open. If $\overline{\text{OE}}$ is tied permanently LOW, a LATE WRITE or READ-MODIFY-WRITE is not possible.
- Write command is defined as $\overline{\text{WE}}$ going low.
- LATE WRITE and READ-MODIFY-WRITE cycles must have both t_{OD} and t_{OEH} met ($\overline{\text{OE}}$ HIGH during WRITE cycle) in order to ensure that the output buffers will be open during the WRITE cycle. The I/Os will provide the previously written data if $\overline{\text{CAS}}$ remains LOW and $\overline{\text{OE}}$ is taken back to LOW after t_{OEH} is met.
- The I/Os are in open during READ cycles once t_{OD} or t_{OFF} occur.
- The first $\chi\overline{\text{CAS}}$ edge to transition LOW.
- The last $\chi\overline{\text{CAS}}$ edge to transition HIGH.
- These parameters are referenced to $\overline{\text{CAS}}$ leading edge in EARLY WRITE cycles and $\overline{\text{WE}}$ leading edge in LATE WRITE or READ-MODIFY-WRITE cycles.
- Last falling $\chi\overline{\text{CAS}}$ edge to first rising $\chi\overline{\text{CAS}}$ edge.
- Last rising $\chi\overline{\text{CAS}}$ edge to next cycle's last rising $\chi\overline{\text{CAS}}$ edge.
- Last rising $\chi\overline{\text{CAS}}$ edge to first falling $\chi\overline{\text{CAS}}$ edge.
- Each $\chi\overline{\text{CAS}}$ must meet minimum pulse width.
- Last $\chi\overline{\text{CAS}}$ to go LOW.
- I/Os controlled, regardless $\overline{\text{UCAS}}$ and $\overline{\text{LCAS}}$.
- The 3 ns minimum is a parameter guaranteed by design.
- Enables on-chip refresh and address counters.

READ CYCLE

(Outputs Controlled by $\overline{\text{CAS}}$)

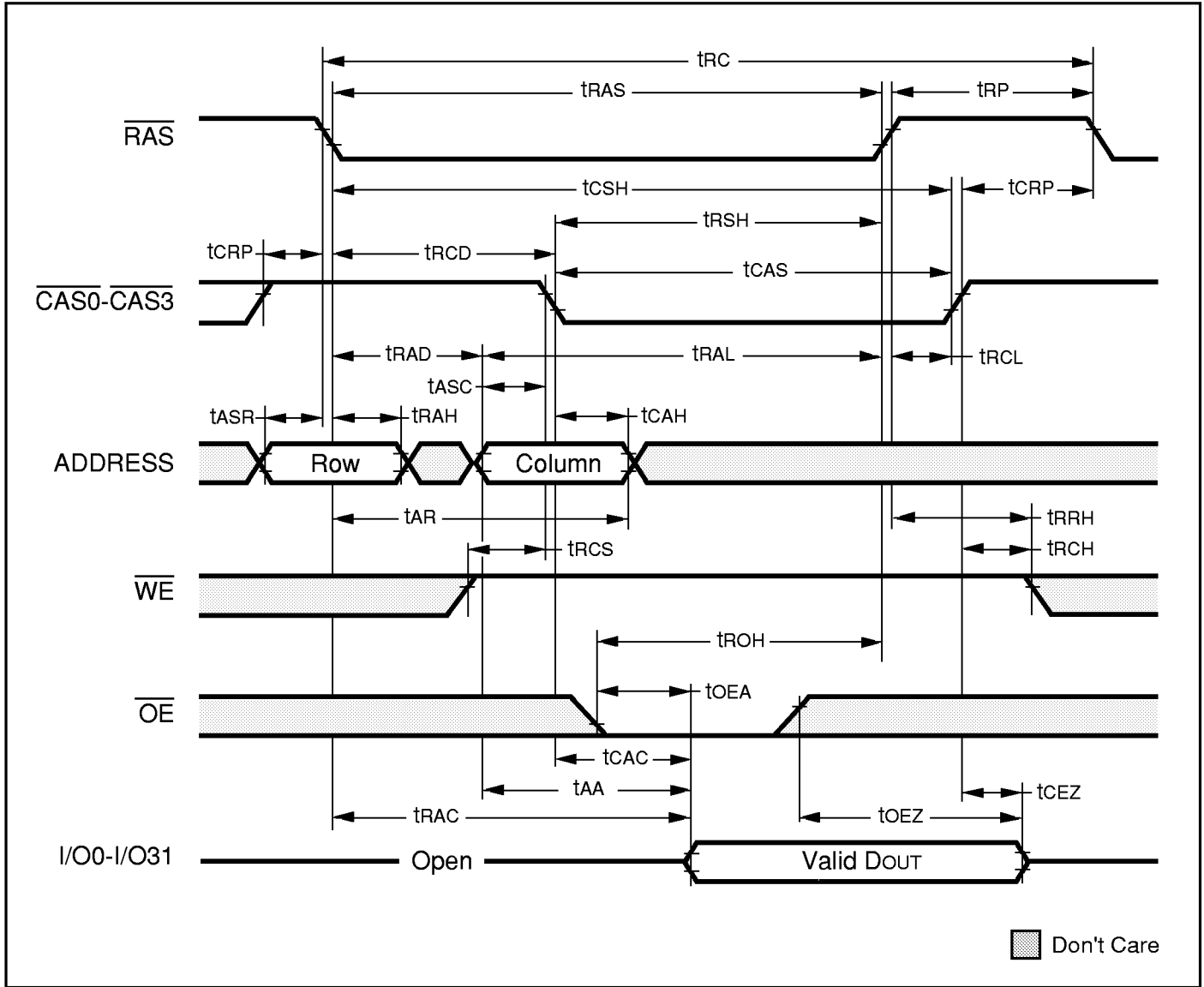

WRITE CYCLE (Early Write)

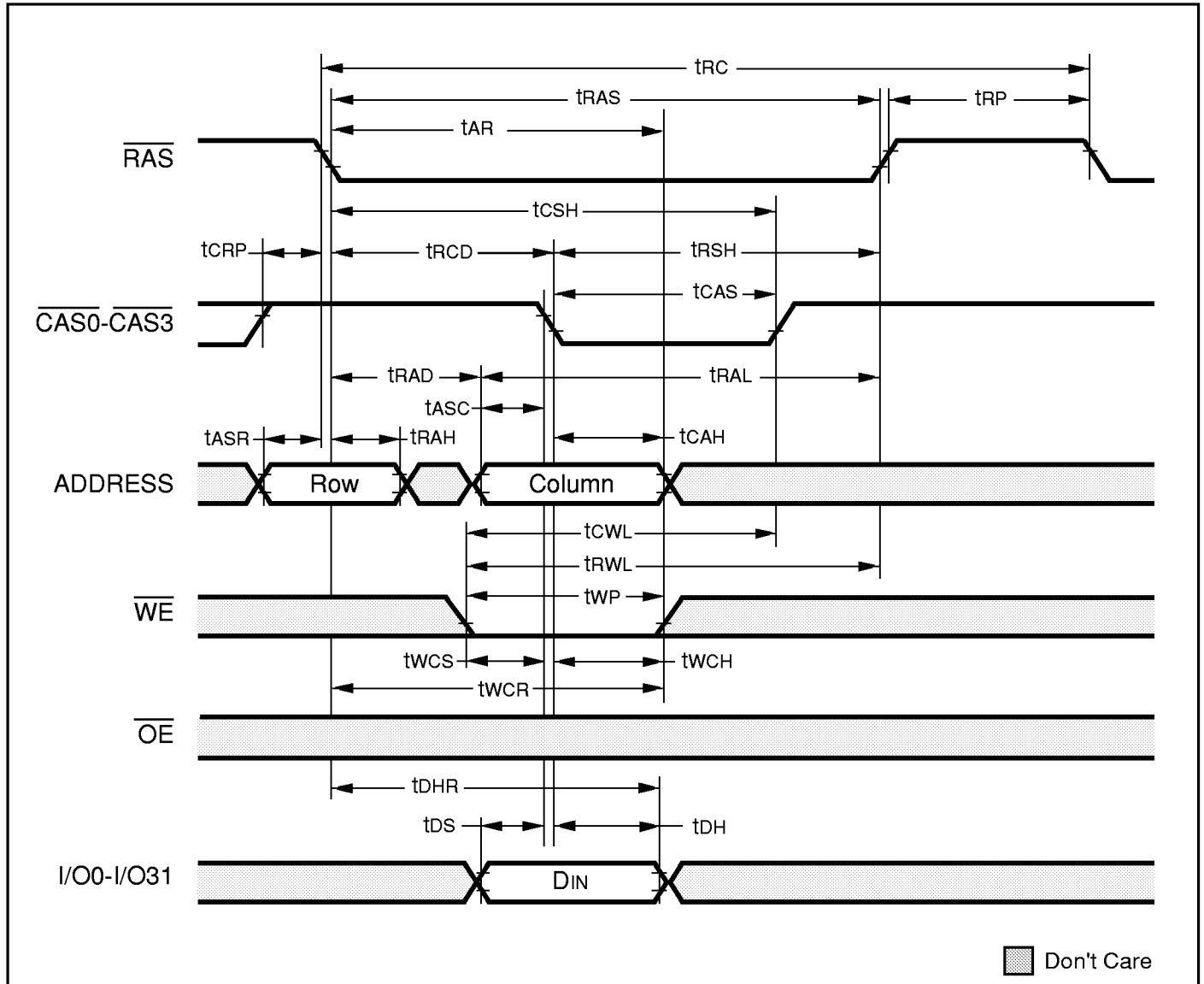

READ-MODIFY-WRITE CYCLE

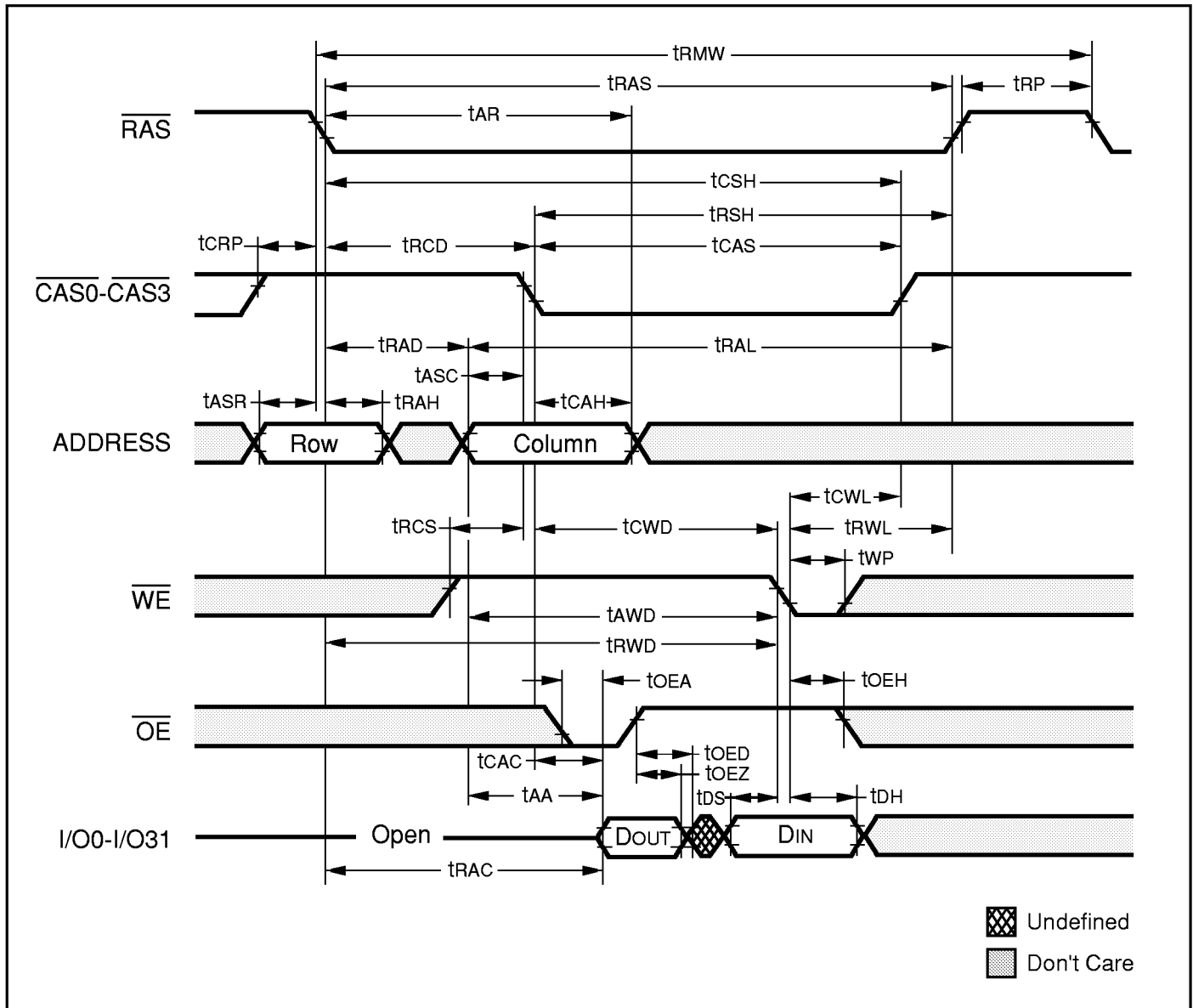

FAST-PAGE-MODE WRITE CYCLE (EARLY WRITE)

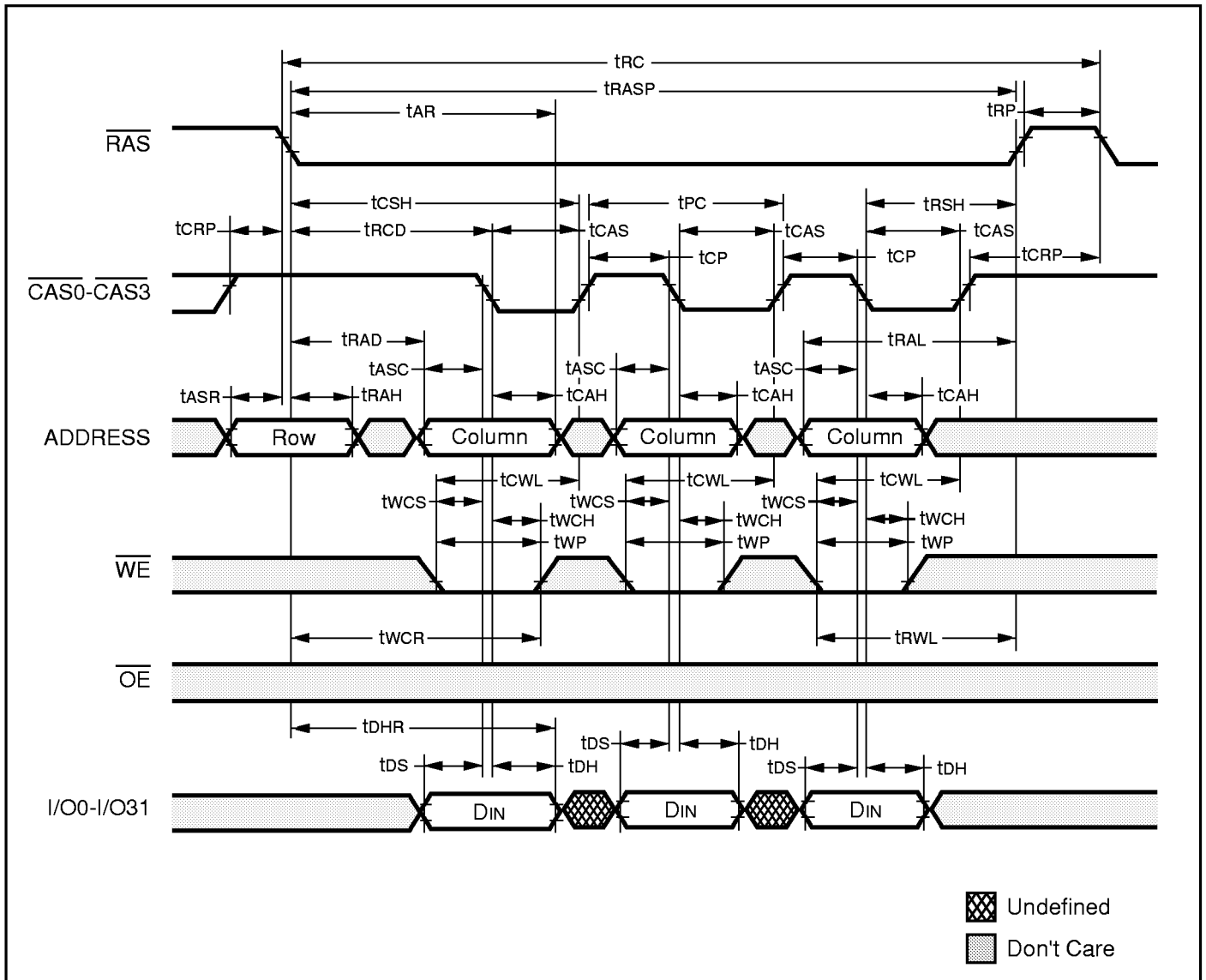

HIDDEN REFRESH READ CYCLE

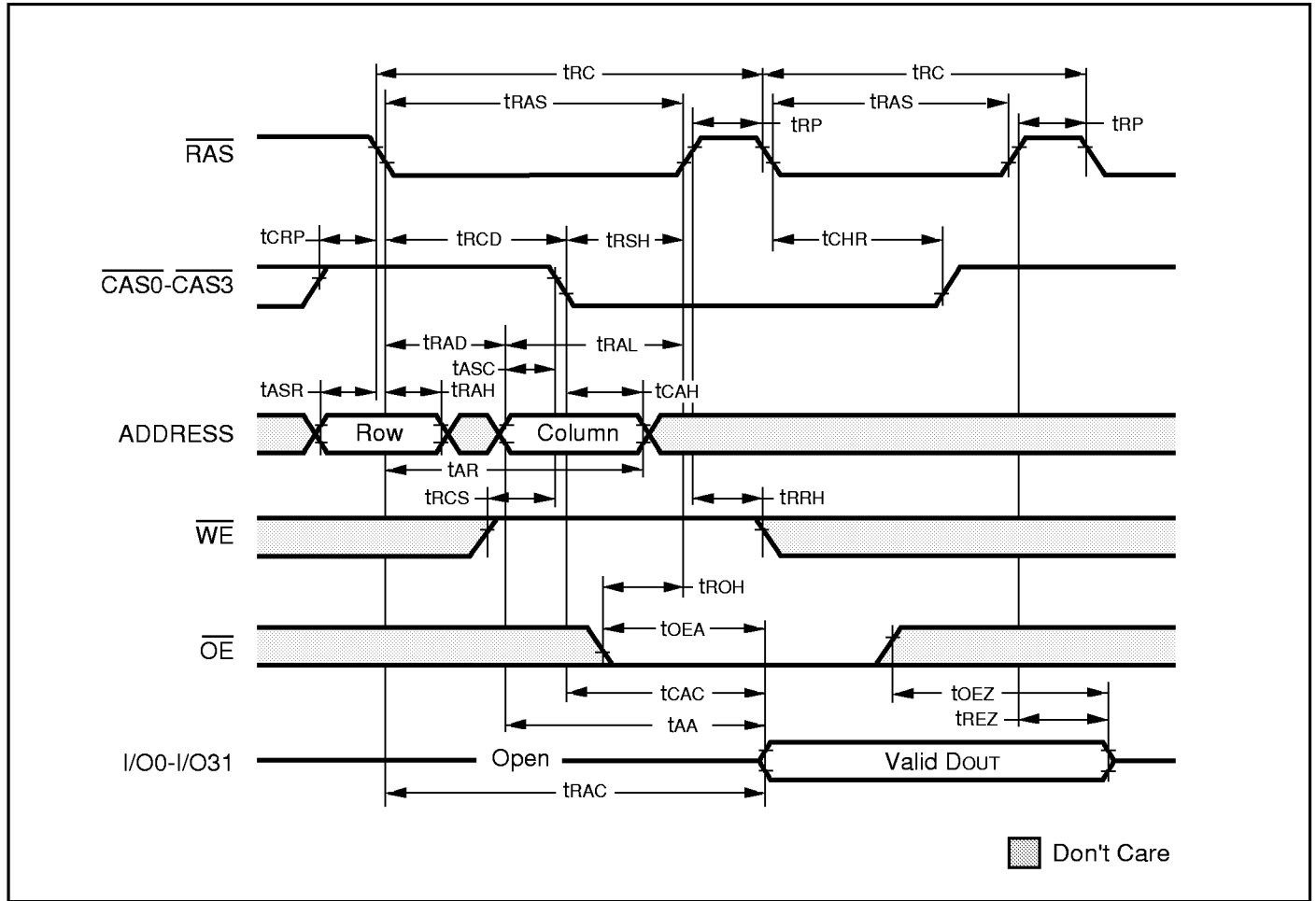

HIDDEN REFRESH WRITE CYCLE

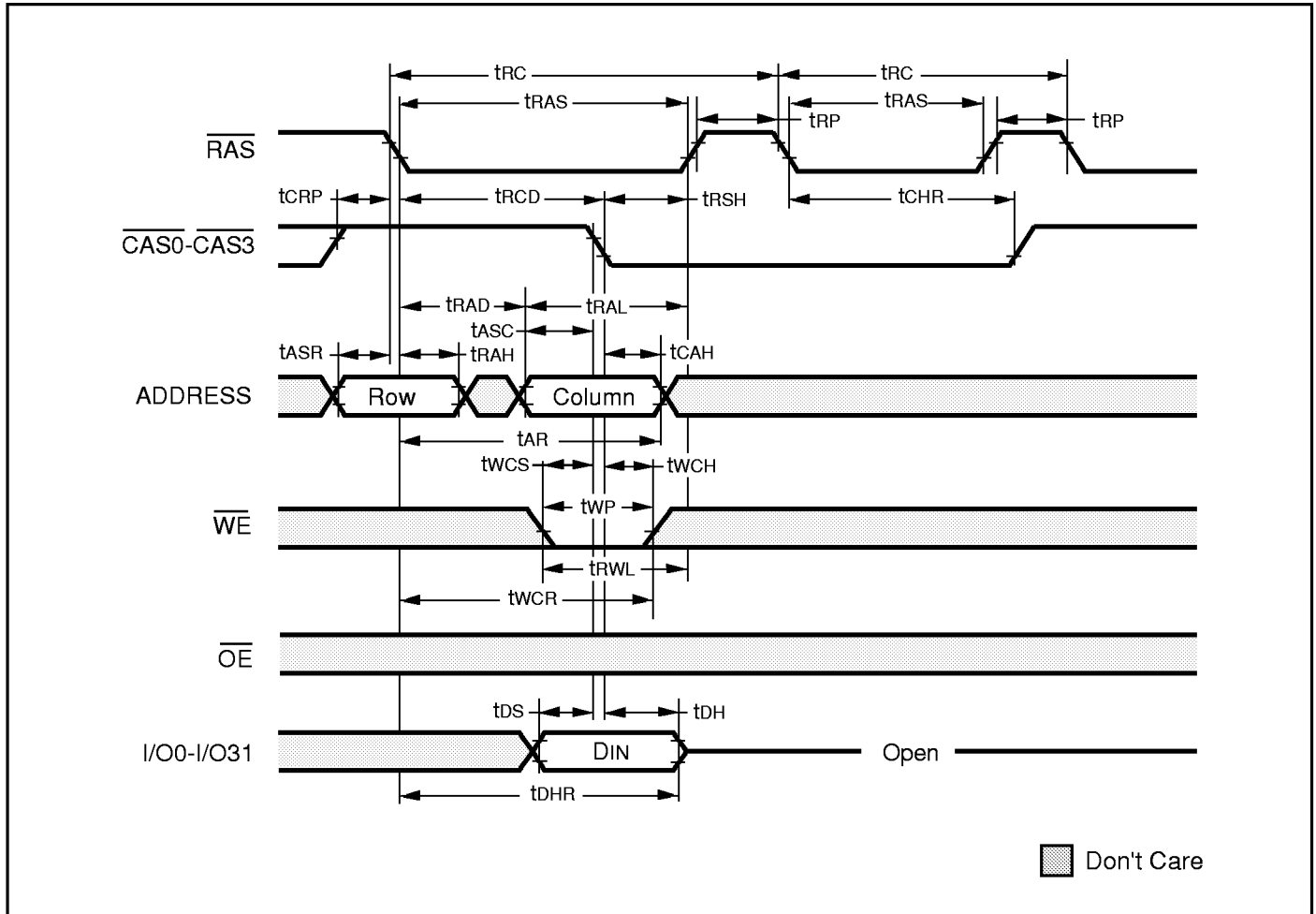

RAS-ONLY REFRESH CYCLE

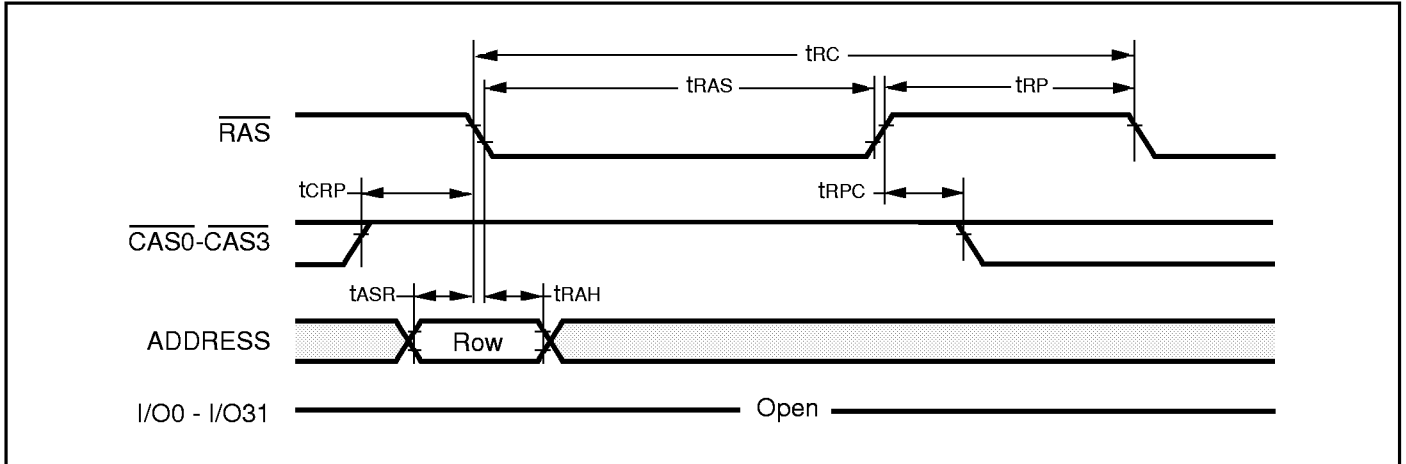

Note:

1. $\overline{\text{WE}}$ and $\overline{\text{OE}}$ = "HIGH" or "LOW"

CAS-BEFORE-RAS REFRESH CYCLE

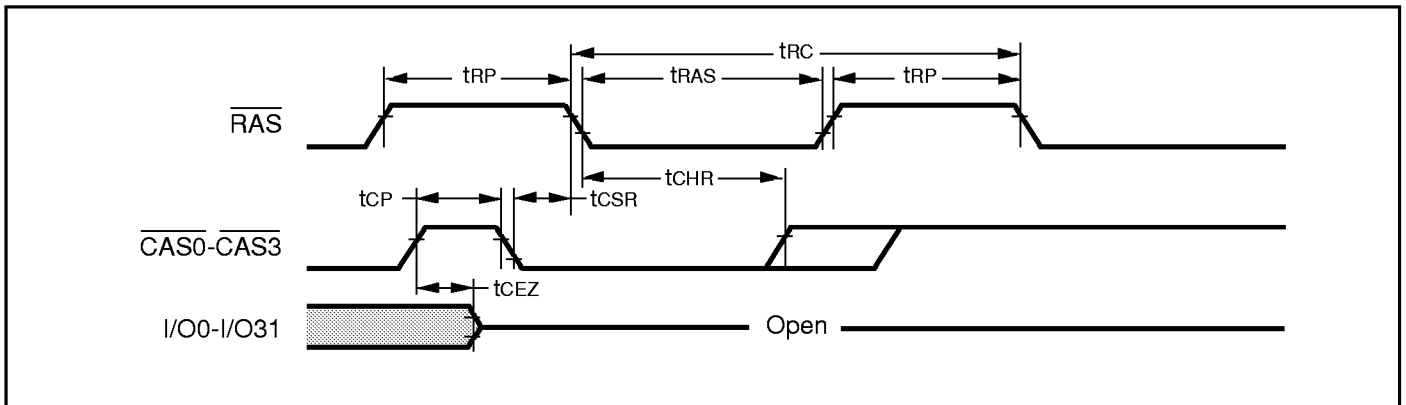

Note:

1. $\overline{\text{WE}}$, $\overline{\text{OE}}$ and Address = "HIGH" or "LOW"

ORDERING INFORMATION**Commercial Range: 0°C to 70°C**

Speed (ns)	Order Part No.	Package
25	IS41LV32256-25PQ	PQFP
	IS41LV32256-25TQ	TQFP
28	IS41LV32256-28PQ	PQFP
	IS41LV32256-28TQ	TQFP
35	IS41LV32256-35PQ	PQFP
	IS41LV32256-35TQ	TQFP

ISSI[®]***Integrated Silicon Solution, Inc.***

2231 Lawson Lane
Santa Clara, CA 95054
Fax: (408) 588-0806
Toll Free: 1-800-379-4774
<http://www.issi.com>