

T-75-07-07

LR4801D Pulse/Tone Dialer LSI

■ Description

The LR4801D is a CMOS pulse/tone dialer LSI providing 18-digit×10-channel memory-including a redial memory.

■ Features

1. Ten 18-digit telephone number memory storage including a redial memory
2. Make ratio : 40%
3. Pulse rate : 10/20pps pin-selectable
4. Key tone output (1kHz)
5. Switchable between DTMF tone dialing and pulse dialing modes
6. Uses a 3.579545 MHz color-burst crystal/ceramic oscillator as a frequency reference
7. PBX pause storage
8. Uses the single contact, the standard 2-of-7 or 2-of-8 matrix keyboard
9. 18-pin dual-in-line package

■ Pin Connections

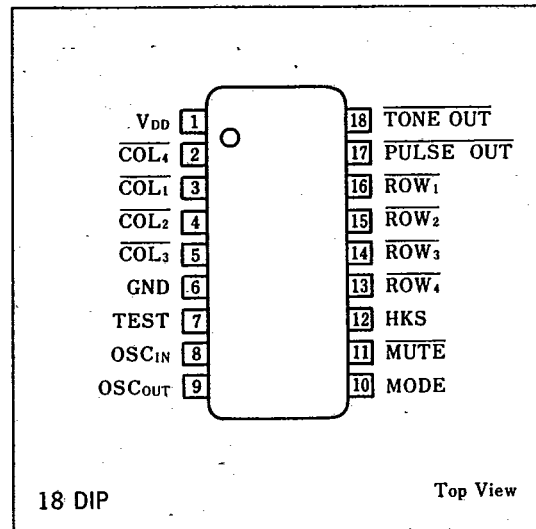

■ Block Diagram

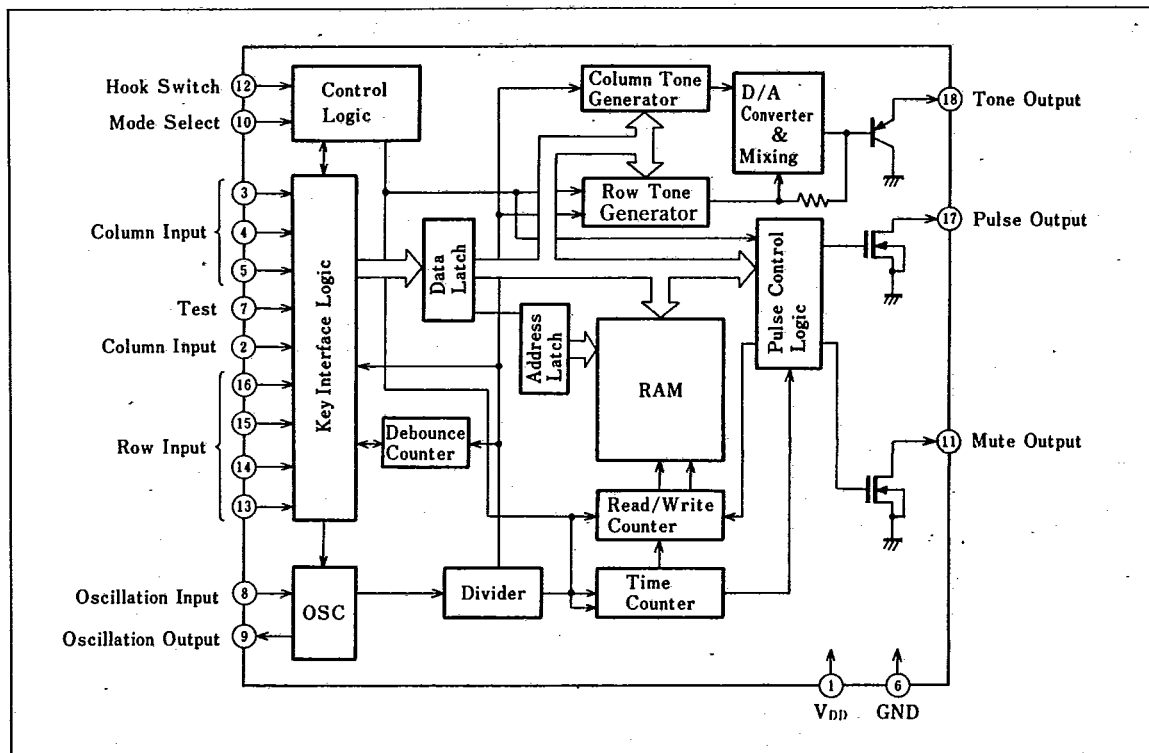

SHARP

Absolute Maximum Ratings

T-75-07-07

Parameter	Symbol	Ratings	Unit	Note
Supply voltage	V_{DD}	6.5	V	1
Input voltage	V_{IN}	-0.3 to +0.3	V	2
	V_{IN2}		V	3
Power dissipation	P_D	500	mW	4
Operating temperature	T_{opr}	-30 to +60	°C	
Storage temperature	T_{opr}	-55 to +150	°C	

Note 1 : Referenced to GND.

Note 2 : The maximum applicable voltage on any pin with respect to GND.

Note 3 : The maximum voltage on any pin with respect to V_{DD} .Note 4 : $T_a=25^\circ\text{C}$

Recommended Operating Conditions

Parameter	Symbol	MIN.	TYP.	MAX.	Unit
Supply voltage	V_{DD}	2		6	V

DC Characteristics

(Ta = -30 to +60°C, Referenced to GND.)

Parameter	Symbol	Conditions	MIN.	TYP.	MAX.	Unit	Note
Input voltage	V_{IL}		GND		$0.2V_{DD}$	V	
	V_{IH}		$0.8V_{DD}$		V_{DD}	V	
Tone output voltage	ROW	$R_L=1k\Omega$	290	350	450	mV_{rms}	
	COLUMN	$R_L=1k\Omega$	380	450	550	mV_{rms}	
Standby current	I_{SB}	$V_{DD}=3.5V$		3	6	μA	1
Operating current	I_{OP}	$V_{DD}=3.5V$		2	3	mA	2
Mute output current	I_{OL}	$V_{DD}=2V, V_{OL}=0.5V$	1.0	2.0		mA	3
Pulse sink output current	I_{PL}	$V_{DD}=2V, V_O=0.5V$	1.0			mA	
Pulse leakage output current	I_{LKG}	$V_{DD}=6V, V_O=6V$			1.0	μA	
Key pull-up input resistance	P_{KP}	$V_{DD}=3.5V$		100		$k\Omega$	4
Key pull-down input resistance	P_{KD}	$V_{DD}=3.5V$		5.0		$k\Omega$	4
Mode pull-up input resistance	R_{MP}	$V_{DD}=3.5V$		100		$k\Omega$	
Mode pull-down input resistance	R_{MD}	$V_{DD}=3.5V$		100		$k\Omega$	
HKS pull-up input resistance	R_{HK}	$V_{DD}=3.5V$		60		$k\Omega$	
Tone output distortion		$V_{DD}\geq 4V$			-20	dB	5
Pre-emphasis	PE_{HB}	$V_{DD}\geq 4V, R_L=1k\Omega$	1.0	2.0	3.0	dB	

Note 1 : All output pins in no-load condition when clock is stopped and when On-Hook

Note 2 : All output pins in no-load condition during key input and when On-Off-Hook (upper row : during pulse mode, lower row : during tone mode)

Note 3 : Applied to the MUTE pin.

Note 4 : Resistance when a ROW pin or COL pin is scanned at 125Hz, at high or low level.

Note 5 : Unwanted frequency components relative to the total power of the fundamental tone signal of the ROW pin and COL pin.

4

T-75-07-07

AC Characteristics

(Ta=25°C)

Parameter	Symbol	MIN.	TYP.	MAX.	Unit	Note
Oscillation start time	t _{OS}			8	ms	1
Key debounce time	t _{DB}	4		32	ms	2
Pulse rate	P _R		10		pps	3
			20			4
Break time	t _B		60		ms	5
Inter-digital pause time	t _{IDP}		1000		ms	5
						6
Mute overlap time	t _{MOL}		2	4	ms	
Pre-digital pause time	t _{PDP}		40		ms	5
Tone output rate	t _{OR}		220		ms	
Tone output time	T _{OPT}	50			ms	7
Tone mute overlap time	T _{OM}	4		32	ms	

Note 1: When a crystal oscillation element with characteristics $R_s=100\Omega$, $L_m=96mH$, $C_m=0.02pF$, $C_h=5pF$, $f=3.579545MHz$ is used.

Note 2: Key input is accepted after oscillation begins if valid after t_{DB}.

Note 3: MODE pin left open.

Note 4: Connect the MODE pin to V_{DD}.

Note 5: During 10-pps pulse mode (1/2 during 20-pps mode).

Note 6: 100 ms during DTMF mode.

Note 7: During normal dialing, the tone output time depends on KEY ON time.

See Fig. right minimum Key ON time and Key OFF time necessary for TONE output.

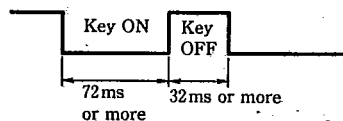

Description Of Operation

The mode select pin of the LR4801D LSI enables either DTMF tone dialing or 10pps/20pps pulse dialing mode to be selected. It is a 10 number memory repertory dialer which, depending on the mode selected, outputs either tone signals or pulse and mute signals in response to the key inputs. A low-cost 3.579545MHz color burst crystal may be used for the oscillator. The device contains 900 bits of RAM (18 digits×5bits×10) enabling it to store up to 10 telephone numbers, including the number last dialed. Numbers up to a maximum of 18 digits can be stored. When used with a PABX system, a pause can be input. The repertory dialer will recognize this pause during auto-dial operations and will suspend output for 4 seconds. When the DTMF tone dialing

mode is selected, 8 types of audio frequency are generated and an output tone conforming to DTMF dialing standards is synthesized from them. In response to ROW and COLUMN key inputs, a dual audio tone output is obtained by division of the 3.579545MHz signal. The D/A converter in this LSI consists of an on-chip R-2R ladder network and an op-amp. The output signal is a staircase approximation of a sine wave. When particularly low distortion is required, an external filtering circuit should be added. When On/Off-Hook in pulse dialing mode, or when On-Hook in DTMF mode, a 1215.9Hz tone is output when a key is depressed.

Pin Descriptions

T-75-07-07

V_{DD} (Pin 1)

This pin is the power supply pin. It is positive with respect to GND (Pin 6). Maximum input voltage is 6.0 volts.

Key Inputs (Pin 2, 3, 4, 7, 13, 14, 15, 16)

Using GND as a common pin, the LR4801D may be used with either a standard 2-of-7 or 2-of-8 matrix keyboard, or with a single contact (Form A) keyboard. Figure 1 shows the keyboard configurations.

In order for the key input to be valid, a single ROW input should be connected to a single COLUMN input. The single ROW and COLUMN inputs should go low simultaneously. Simultaneous multiple key depression invalidates the key input.

If a single tone output is required as a check, multiple keys in the same ROW or COLUMN may be pressed simultaneously in DTMF mode. No tone at all is output if multiple keys in the diagonal direction are depressed simultaneously. Multiplekey depressions of ROW₄ and COL₄ inputs are not recognized. Oscillation begins when the first key input is detected. A key search is then performed on the ROW and COLUMN inputs alternately using high and low levels.

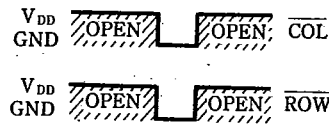
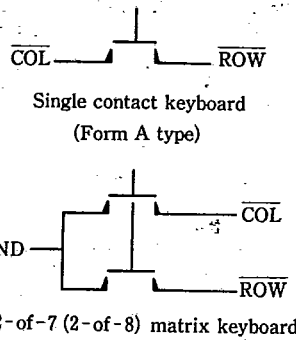

Fig. 1. Keyboard configurations

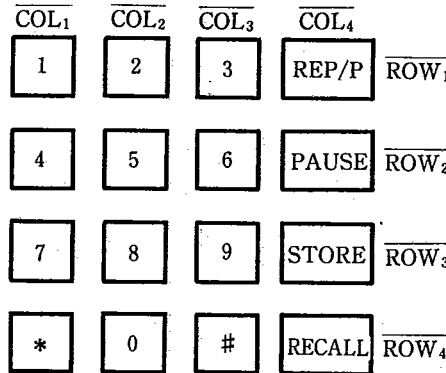

Fig. 2 Key matrix

Table 1. Key Functions

Key	Pulse dialing mode	DTMF mode
0-9	Data key	Data key
*	Pause key	Data key
#	Control key-redial (Note 1)	Data key
RED/P	Control/data key (See Note 2)	Control/data key (See Note 2)
Pause	Data key (pause key)	Data key (pause key)
Store	Control Key (store)	Control key (store)
Recall	Control Key (recall)	Control key (recall)

Note 1 : If the # key is used for the first key input in pulse mode, it functions as a control key. In all other cases, # key input is ignored.

Note 2 : If the RED/P is the first key used when Off-Hook, then it functions as a control key, causing redialing to occur. In other cases it functions as a pause key.

Note 3 : A pause key input, in tone dialing mode, is valid when redialing or recalling.

GND (Pin 6)

Negative power supply pin.

Oscillator (Pins 8 and 9)

The LR4801D has on-chip inverters with enough loop-gain to enable an oscillator to be formed by simply connecting either a low-cost TV color burst crystal or a ceramic oscillator across the OSC_{IN} and OSC_{OUT} pins. Table 2 shows the frequencies of the output tones when a 3.579545MHz crystal oscillator is used.

Table 2

	Standard DTMF [Hz]	*LR4801D Output Tone [Hz]	Deviation from Standard DTMF [%]
f1 (ROW1)	697	701.3	+0.62
f2 (ROW2)	770	771.4	+0.19
f3 (ROW3)	852	857.2	+0.61
f4 (ROW4)	941	935.1	-0.63
f5 (COL1)	1209	1215.9	+0.57
f6 (COL2)	1336	1331.7	-0.32
f7 (COL3)	1477	1471.9	-0.35

No single tone is generated on COL4.

* When using a 3.579545MHz crystal. Note that any deviations in the crystal frequency will directly affect the frequency of the output tone.

Mode Select (Pin 10)

This pin enables switching between DTMF dialing mode and the 10/20pps pulse dialing modes. Table 3 shows the relationship between the pin connections and the operating modes. If the input to the mode select pin is changed during pulse output, the mode transition occurs when t_{IDP} (max. 1 sec) has elapsed following data output in that mode or when a maximum of 3.6sec has elapsed after the mode transition during tone output.

Table 3

Pin Connection	Operation mode
V_{DD}	20pps pulse dialing
Open	10pps pulse dialing
GND	DTMF tone dialing

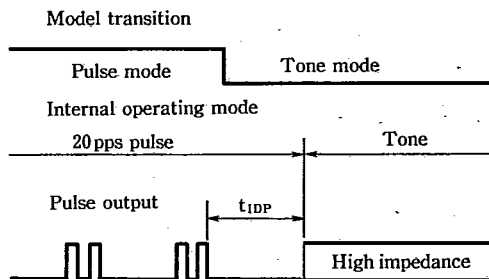

Fig. 3 Mode change timing diagram

T-75-07-07

Mute Output (Pin 11)

The Mute output pin consists of an N-channel open-drain transistor. In pulse dialing mode, the Mute Output returns to GND level upon key input or pulse output. In tone dialing mode, the output returns to GND level upon key input or tone output during auto-dialing.

Hook Switch Input (Pin 12)

This pin is the hook switch input. An internal pull-up resistor connects it to V_{DD} . When left open or at the V_{DD} level, the circuit is in On-Hook mode. When connected to GND, it is in Off-Hook mode (dialing mode).

Pulse Output (Pin 17)

This pin outputs pulses when in 10pps or 20pps pulse dialing mode. It is an N-channel open-drain output capable of driving an external transistor. The pulse Make/Break ratio is 32%/68%. In DTMF tone dialing mode, it is in a high impedance state.

Tone Output (Pin 18)

The Tone Output is connected to the emitter of an on-chip bipolar transistor, the collector of which is connected to ground. The ROW and COLUMN signal inputs to this transistor are connected to an on-chip op-amp to ensure stable output levels. In DTMF tone-dialing mode, the DTMF signal is output as described below. The ROW and COLUMN outputs are digitally synthesized. Figures 4 and 5 show the waveforms output from the on-chip D/A converters. Without filtering, the distortion of the signal is within 7% of the ideal waveform. The ROW and COLUMN signals are combined by the on-chip op-amp to form a dual-tone output waveform.

Test Input (Pin 7)

This is used for LSI testing and is internally connected to V_{DD} through a pull-up resistor.

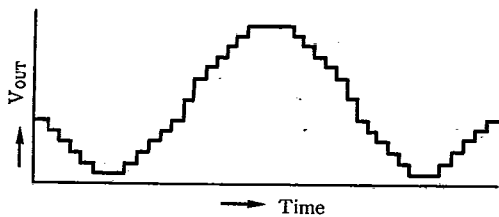

Fig. 4 Row signal tone waveform

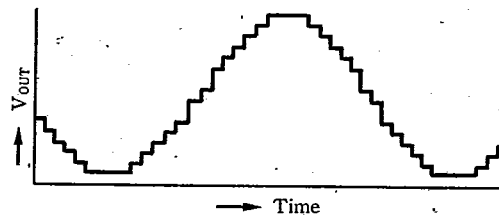

Fig. 5 Column signal tone waveform

Functional Description

Normal Dialing

Normal dialing involves numeric key input while the phone is Off-Hook. If the key input is valid, the data is stored at location 0 in internal RAM. The memory operations occur on a FIFO (First-in First-out) basis and telephone numbers up to 18 digits long can be stored. Key input of more than 19 digits causes memory to be cleared and filled with new data. In tone dialing mode, the DTMF tone is output in response to the key inputs.

Memory Function

During normal dialing each key input is written to the buffer memory (RAM location 0). The dialed number stored in this temporary buffer can be transferred to and stored in another location (1-9) in the storage memory. The LR4801D automatically loads the telephone number input from the key pad into the buffer regardless of whether the phone is On-Hook or Off-Hook. When the **STORE** **N** (N=1,9) key sequence is input, the contents of the buffer are transferred to one of the memory locations 1-9. The existing contents of the buffer are automatically overwritten when a new number is input.

Note* Key input is accepted for 0.6 sec of transferring time and then the store operation is reset by switching the Hook Switch on and off.

Redial Function

If the **RED/P** key is input while the hook-switch is off (i.e., HKS pin at GND level), then the contents of the buffer memory are read out and redialing is performed. If the **#** key is the first input after the hook-switch pin has been grounded, the number in buffer memory is redialed.

Recall Function

When the hook-switch is off and a **RECALL** **N** (N=1,9) key input sequence occurs, dialing starts from the time the **N** key becomes valid.

Note* By pushing a **RECALL** or **STORE** key when pulse are output in Off-Hook mode, pulse output is halted and a mode transition occurs.

Pause/Auto-Dialing Function

The LR4801D allows pauses to be programmed within the 17 digits of the telephone number. A pause is recorded in memory by entering the **PAUSE** key. If a pause code is detected during the execution of a redial or recall auto-dial operation, dialing is automatically suspended. After 4 seconds the rest of the number is then dialed.

During an auto-dialing operation in DTMF mode, **PAUSE** key input causes data to be written into RAM. But a pause is output only when the memory contents are dialed.

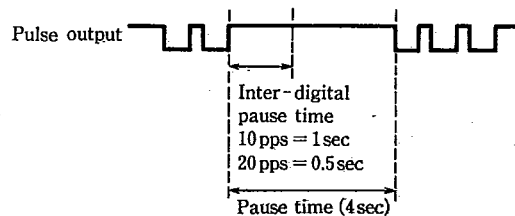

Tone output
Auto-dialing



Sample Operations

[A]

1. ON HOOK
2. Input "0 PAUSE 98-7654" ; "0 PAUSE 98-7654" is written to the buffer memory.
3. Input "STORE 2" ; "0 PAUSE 98-7654" is transferred to and stored in memory location 2.
4. OFF HOOK
5. Input "RECALL 2" ; "0" is transmitted and, after 4 seconds, "98-7654" is automatically transmitted.

[B]

1. OFF HOOK
2. Input "0 PAUSE 1234" ; "0 PAUSE 1234" is transmitted and simultaneously written into the buffer memory.
3. BUSY confirmation ; (The other party is engaged.)
4. ON HOOK
5. OFF HOOK
6. RED/P ; "0" is transmitted and, after 4 seconds, "1234" is automatically transmitted.
7. ON HOOK
8. Input "STORE 3" ; "0 PAUSE 1234" is transferred to and stored in memory location 3.
9. OFF HOOK
10. Input "RECALL 3" ; "0" is transmitted and, after 4 seconds, "1234" is automatically transmitted.
11. BUSY confirmation
12. ON HOOK
13. OFF HOOK
14. Input REDIAL ; "0" is transmitted and, after 4 seconds, "1234" is automatically transmitted.

Timing Diagram

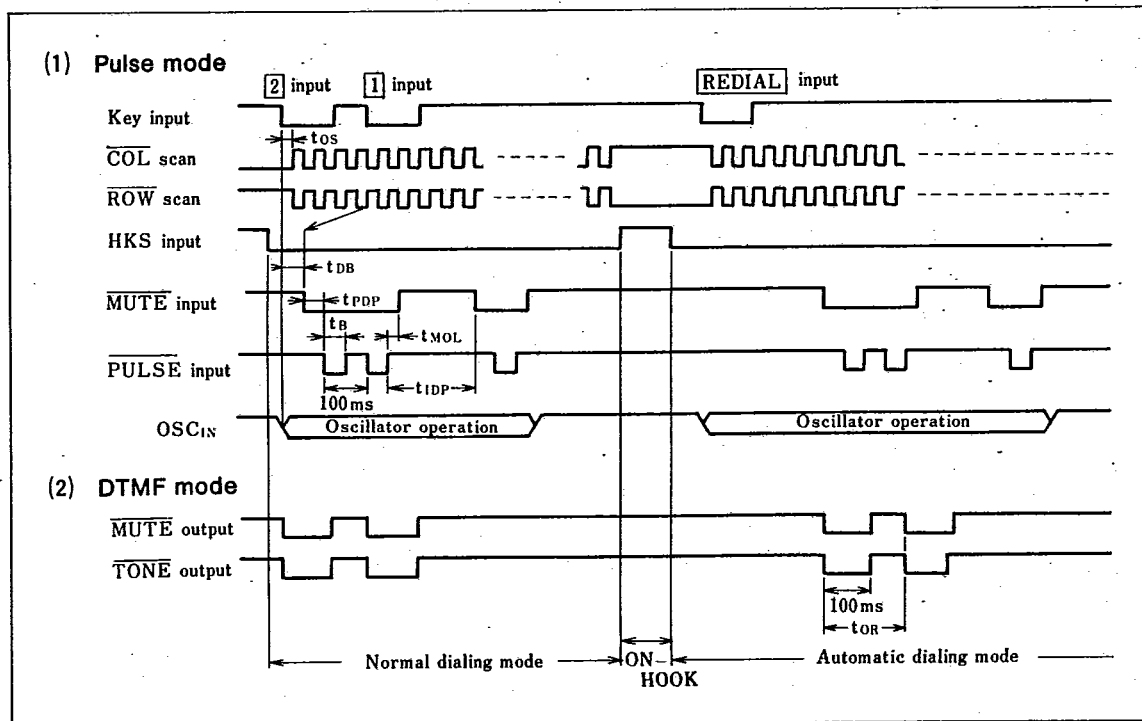

T-75-07-07

System Configuration Example

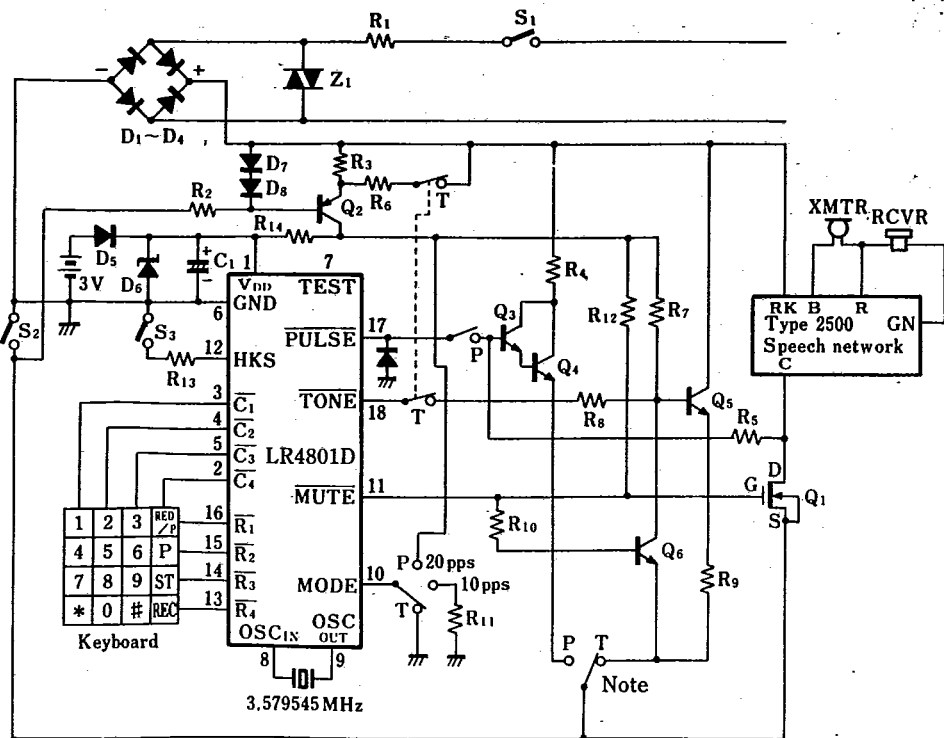

Note : Connect the switch to "P" for pulse mode and "T" for tone mode.

- | | |
|---------------------------|--|
| Z ₁ = 10DK820 | Q ₁ = 2N6660 |
| R ₁ = 22 Ω, 1W | Q ₂ = 2N5401 |
| R ₂ = 560k Ω | Q ₃ = 2N5550 |
| R ₃ = 1.5k Ω | Q ₄ = 2N5550 |
| R ₄ = 150 Ω | Q ₅ = 2N5550 |
| R ₅ = 270k Ω | Q ₆ = 2N5550 |
| R ₆ = 51 Ω | S ₁ , S ₂ , S ₃ = Hook switch |
| R ₇ = 5k Ω | D ₁ ~ D ₄ = 1N4004 |
| R ₈ = 100 Ω | D ₅ = 1N270 |
| R ₉ = 200 Ω | D ₆ = 1N752 (5.6V) |
| R ₁₀ = 100 Ω | D ₇ = 1N914 |
| R ₁₁ = 1M Ω | D ₈ = 1N914 |
| R ₁₂ = 10k Ω | |
| R ₁₃ = 470 Ω | |
| R ₁₄ = 39 Ω | |

C₁ = 68 μF (Insert a capacitor to smooth the power supply and prevent latch up.)

