

4195

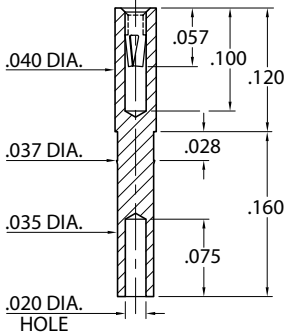

4195-0-19-XX-04-XX-10-0
Wire termination and
press-fit in .036 hole (#64 drill)

8210

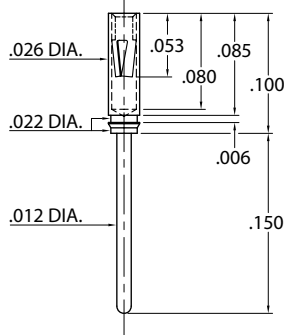

8210-0-15-15-04-27-04-0
Press-fit in .024/.027 stepped hole

0464

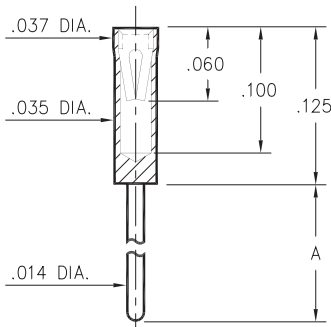

Basic Part Number	Length A
0464-0	.125
0464-1	.250

0464-X-15-XX-10-XX-04-0
Solder mount in .016 min.
mounting hole

9225

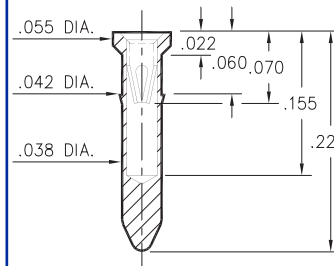

9225-0-15-XX-10-XX-10-0
Press-fit in .039 mounting hole

0529

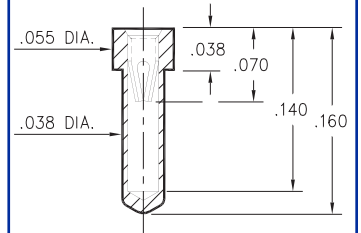

0529-0-15-XX-10-XX-10-0
.040 min. mounting hole

8947

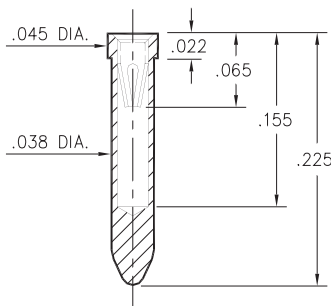

8947-0-15-XX-10-XX-10-0
Solder mount in .040 min.
mounting hole

SPECIFICATIONS

SHELL MATERIAL:
Brass Alloy 360, 1/2 Hard

CONTACT MATERIAL:
Beryllium Copper Alloy 172, HT

DIMENSION IN INCHES
TOLERANCES ON:
LENGTHS: ±.005
DIAMETERS: ±.002
ANGLES: ± 2°

ORDER CODE: XXXX - X - XX - XX - XX - XX - XX - 0

BASIC PART # →

SPECIFY SHELL FINISH:

- 01 200µ" TIN/LEAD OVER NICKEL
- 80 200µ" TIN OVER NICKEL ◊
- 15 10µ" GOLD OVER NICKEL ◊

SPECIFY CONTACT FINISH:

- 02 100µ" TIN/LEAD OVER NICKEL
- 84 100µ" TIN OVER NICKEL ◊
- 27 30µ" GOLD OVER NICKEL ◊



SELECT CONTACT

#04 or #10 CONTACT (DATA ON PAGE 205)