



21014

1M (262,144 x 4) DYNAMIC RAM WITH FAST PAGE MODE

■ Performance Range

Symbol	Parameter	21014-07	21014-08	Units
t_{RAC}	Access Time from \overline{RAS}	70	80	ns
t_{CAC}	Access Time from \overline{CAS}	20	25	ns
t_{RC}	Read Cycle Time	130	160	ns

■ Fast Page Mode Operation

■ \overline{CAS} before \overline{RAS} refresh capability

■ Common I/O Using "Early Write"

■ Single 5V \pm 10% Power Supply

■ 512 Cycles/8 ms Refresh

■ Available in Plastic DIP (P) and SOJ (T) Packages

Intel's 21014 is a CMOS high speed 262,144 x 4 dynamic RAM optimized for high performance applications such as mainframes, graphics and microprocessor systems.

The 21014 features Fast Page Mode operation which allows high speed random access of memory cells within the same row.

\overline{CAS} before \overline{RAS} refresh capability provides on-chip auto refresh as an alternative to \overline{RAS} only refresh. All Inputs, Outputs and Clocks are fully CMOS and TTL compatible.

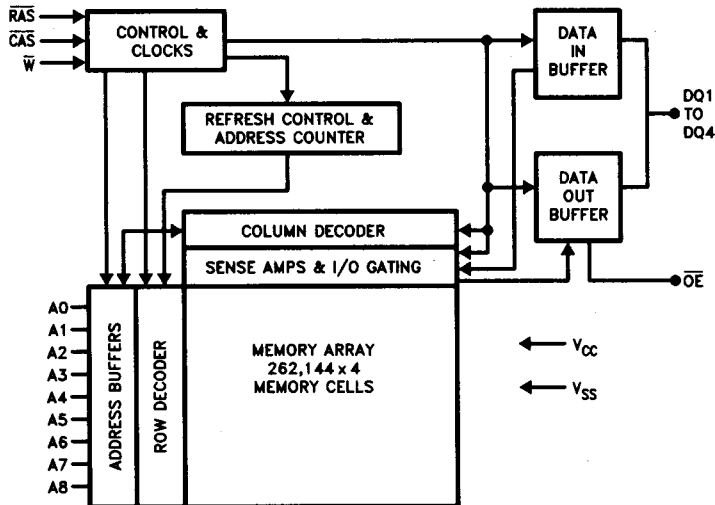
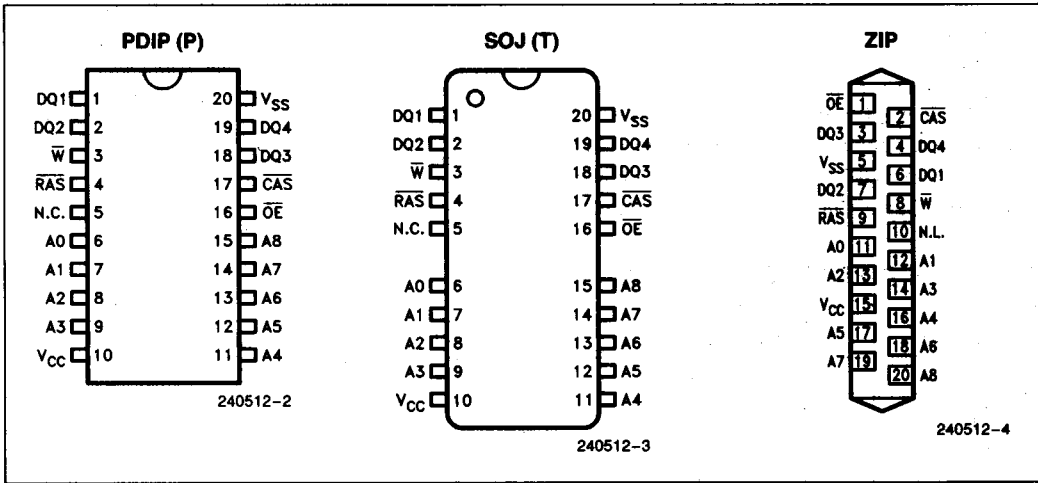

Figure 1. Block Diagram

240512-1

PIN CONFIGURATIONS



PIN DESCRIPTIONS

Pin Name	Pin Function
A ₀ -A ₈	Address Inputs
\bar{RAS}	Row Address Strobe
\bar{CAS}	Column Address Strobe
\bar{W}	Read/Write Input
\bar{OE}	Data Output Enable
DQ ₁ -DQ ₄	Data In/Data Out
V _{CC}	Power (+5V)
V _{SS}	Ground
N.C.	No Connection
N.L.	No Lead

ABSOLUTE MAXIMUM RATINGS*

Voltage on Any Pin Relative to V_{SS} (V_{IN} , V_{OUT}) -1V to +7.0V

Voltage on Power Supply Relative to V_{SS} (V_{CC}) -1V to +7.0V

Storage Temperature (T_{stg}) -55°C to +125°C

Power Dissipation (PD) 600 mW

Short Circuit Output Current (I_{OS}) 50 mA

NOTICE: This is a production data sheet. The specifications are subject to change without notice.

*WARNING: Stressing the device beyond the "Absolute Maximum Ratings" may cause permanent damage. These are stress ratings only. Operation beyond the "Operating Conditions" is not recommended and extended exposure beyond the "Operating Conditions" may affect device reliability.

RECOMMENDED OPERATING CONDITIONS

Voltage referenced to V_{SS} , $T_A = 0^\circ\text{C}$ to 70°C

Symbol	Parameter	Min	Typ	Max	Unit
V_{CC}	Supply Voltage	4.5	5.0	5.5	V
V_{SS}	Ground	0	0	0	V
V_{IH}	Input High Voltage	2.4	—	$V_{CC} + 1$	V
V_{IL}	Input Low Voltage	-1.0	—	0.8	V

NOTES:

- V_{IL} (min) = 1.0V for continuous DC level.
- V_{IL} (min) = 2.0V for pulse width < 20 ns.

CAPACITANCE $T_A = 25^\circ\text{C}$

Symbol	Parameter	Min	Max	Unit
C_{IN1}	Input Capacitance (A_0 - A_9)	—	6	pF
C_{IN2}	Input Capacitance (\overline{RAS} , \overline{CAS} , \overline{W} , \overline{OE})	—	7	pF
C_{OUT}	Output Capacitance (DQ_1 - DQ_4)	—	7	pF

DC AND OPERATING CHARACTERISTICS

Recommended operating conditions unless otherwise noted

Symbol	Parameter	Speed	Min	Max	Units
I_{CC1}	Operating Current (\overline{RAS} and \overline{CAS} Cycling @ $t_{RC} = \text{Min}$)	-07	—	80	mA
		-08	—	70	mA
I_{CC2}	Standby Current (TTL Power Supply Current)		—	2	mA
I_{CC3}	\overline{RAS} Only Refresh Current ($\overline{CAS} = V_{IH}$, \overline{RAS} Cycling @ $t_{RC} = \text{Min}$)	-07	—	80	mA
		-08	—	70	mA
I_{CC4}	Fast Page Mode Current ($\overline{RAS} = V_{IL}$, \overline{CAS} Cycling @ $t_{PC} = \text{Min}$)	-07	—	65	mA
		-08	—	55	mA
I_{CC5}	Standby Current (CMOS Power Supply Current)		—	1	mA

DC AND OPERATING CHARACTERISTICS (Continued)

Recommended operating conditions unless otherwise noted

Symbol	Parameter	Speed	Min	Max	Units
I_{CC6}	\overline{CAS} -before- \overline{RAS} Refresh Current (\overline{RAS} and \overline{CAS} Cycling @ $t_{RC} = \text{Min}$)	-07 -08	—	80 70	mA mA
I_{IL}	Input Leakage Current (Any Input $0 \leq V_{IN} \leq 6.5V$ All Other Pins = 0V)		-10	10	μA
I_{OL}	Output Leakage Current (Data Out is Disabled and $0 \leq V_{OUT} \leq 5.5V$)		-10	10	μA
V_{OH}	Output High Voltage Level ($I_{OH} = -5 \text{ mA}$)		2.4	—	V
V_{OL}	Output Low Voltage Level ($I_{OL} = 4.2 \text{ mA}$)		—	0.4	V

NOTE:

I_{CC1} , I_{CC3} , I_{CC4} and I_{CC6} are dependent on output loading and cycle rates. Specified values are obtained with the output open. I_{CC} is specified as average current.

AC CHARACTERISTICS(1, 2, 3)

$T_A = 0^\circ C$ to $70^\circ C$, $V_{CC} = 5V \pm 10\%$

Symbol	Parameter	21014-07		21014-08		Units	Notes
		Min	Max	Min	Max		
t_{REF}	Time between Refresh		8		8	ms	
t_{RC}	Random R/W Cycle Time	130		160		ns	
t_{RWC}	RMW Cycle Time	185		205		ns	
t_{RAC}	Access Time from \overline{RAS}		70		80	ns	4, 7
t_{CAC}	Access Time from \overline{CAS}		20		25	ns	5, 7
t_{AA}	Access Time from Column Address		35		40	ns	6, 7
t_{CLZ}	\overline{CAS} to Output in Low Z	0		0		ns	
t_{OFF}	Output Buffer Turn-Off Delay Time	0	20	0	20	ns	8
t_T	Transition Time	3	50	3	50	ns	
t_{RP}	\overline{RAS} Precharge Time	50		60		ns	
t_{RAS}	\overline{RAS} Pulse Width	70	10K	80	10K	ns	
t_{RSH}	\overline{RAS} Hold Time	20		20		ns	
t_{CRP}	\overline{CAS} to \overline{RAS} Precharge Time	10		10		ns	
t_{RCD}	\overline{RAS} to \overline{CAS} Delay Time	20	50	25	60	ns	9, 10
t_{CAS}	\overline{CAS} Pulse Width	20	10K	25	10K	ns	
t_{CSH}	\overline{CAS} Hold Time	70		80		ns	

7

AC CHARACTERISTICS^(1, 2, 3) (Continued)

 $T_A = 0^\circ\text{C to } 70^\circ\text{C}, V_{CC} = 5\text{V} \pm 10\%$

Symbol	Parameter	21014-07		21014-08		Units	Notes
		Min	Max	Min	Max		
t_{CPN}	\overline{CAS} Precharge Time	10		10		ns	
t_{ASR}	Row Address Set-Up Time	0		0		ns	
t_{RAH}	Row Address Hold Time	10		15		ns	
t_{ASC}	Column Address Set-Up Time	0		0		ns	
t_{CAH}	Column Address Hold Time	15		20		ns	
t_{AR}	Column Address Time Referenced to \overline{RAS}	55		65		ns	
t_{RAD}	\overline{RAS} to Column Address Delay Time	15	35	20	40	ns	11
t_{RAL}	Column Address to \overline{RAS} Lead Time	35		40		ns	
t_{RCS}	Read Command Set-Up Time	0		0		ns	
t_{RRH}	Read Command Hold Time Referenced to \overline{RAS}	10		10		ns	12
t_{RCH}	Read Command Hold Time Referenced to \overline{CAS}	0		0		ns	12
t_{WCS}	Write Command Set-Up Time	0		0		ns	13
t_{WCH}	Write Command Hold Time	15		15		ns	
t_{WCR}	Write Command Hold Time Referenced to \overline{RAS}	55		65		ns	
t_{WP}	\overline{WE} Pulse Width	15		20		ns	
t_{RWL}	Write Command to \overline{RAS} Lead Time	20		20		ns	
t_{CWL}	Write Command to \overline{CAS} Lead Time	20		20		ns	
t_{DS}	D_{IN} Set-Up Time	0		0		ns	
t_{DH}	D_{IN} Hold Time	15		20		ns	
t_{DHR}	Data-In Hold Time Referenced to \overline{RAS}	55		65		ns	
t_{RWD}	\overline{RAS} to \overline{WE} Delay Time	100		110		ns	13
t_{CWD}	\overline{CAS} to \overline{WE} Delay Time	45		55		ns	13
t_{AWD}	Column Address to \overline{WE} Delay Time	65		70		ns	
t_{RPC}	\overline{RAS} Precharge Time to \overline{CAS} Active Time	10		10		ns	
t_{CSR}	\overline{CAS} Set-Up Time for \overline{CAS} before \overline{RAS} Refresh	10		10		ns	

AC CHARACTERISTICS^(1, 2, 3) (Continued)

T_A = 0°C to 70°C, V_{CC} = 5V ± 10%

Symbol	Parameter	21014-07		21014-08		Units	Notes
		Min	Max	Min	Max		
t _{CHR}	CAS Hold Time for $\overline{\text{CAS}}$ before $\overline{\text{RAS}}$ Refresh	30		30		ns	
t _{CPT}	Refresh Counter Test $\overline{\text{CAS}}$ Precharge Time	40		40		ns	
t _{ROH}	$\overline{\text{RAS}}$ Hold Time Referenced to $\overline{\text{OE}}$	20		20		ns	
t _{OE A}	$\overline{\text{OE}}$ Access Time		20		20	ns	
t _{OE D}	$\overline{\text{OE}}$ to Data Delay	20		20		ns	
t _{OE Z}	Output Buffer Turn Off Delay Time from $\overline{\text{OE}}$	0	20	0	20	ns	
t _{OE H}	$\overline{\text{OE}}$ Command Hold Time	20		20		ns	

FAST PAGE MODE

Symbol	Parameter	21014-07		21014-08		Units	Notes
		Min	Max	Min	Max		
t _{PC}	Fast Page Mode Cycle Time	50		55		ns	
t _{PRWC}	Fast Page Mode RMW Cycle Time	100		105		ns	
t _{CPA}	Access Time from $\overline{\text{CAS}}$ Precharge		45		45	ns	7, 14
t _{CP}	Fast Page Mode $\overline{\text{CAS}}$ Precharge Time	10		10		ns	
t _{RASP}	$\overline{\text{RAS}}$ Pulse Width (Fast Page Mode)	70	100K	80	100K	ns	

NOTES:

1. An initial pause of 200 μs is required after power-up followed by any 8 RAS-only cycles before proper device operation is achieved.
2. A.C. characteristics assume t_T = 5 ns.
3. V_{IH} (min) and V_{IL} (max) are reference levels for measuring timing of input signals. Also, transition times are measured between V_{IH} (min) and V_{IL} (max).
4. Assumes that t_{RCD} ≤ t_{RCD} (max), t_{RAD} ≤ t_{RAD} (max). If t_{RCD} (or t_{RAD}) is greater than the maximum recommended value shown in this table t_{RAC} will be increased by the amount that t_{RCD} (or t_{RAD}) exceeds the value shown.
5. If t_{RCD} ≥ t_{RCD} (max), t_{RAD} ≥ t_{RAD} (max), and t_{ASC} ≥ t_{AA} - t_{CAC} - t_T, access time is t_{CAC}.
6. If t_{RAD} ≥ t_{RAD} (max) and t_{ASC} ≤ t_{AA} - t_{CAC} - t_T, access time is t_{AA}.
7. Measured with a load equivalent to two TTL loads and 100 pF.
8. t_{OFF} is specified that output buffer changes to high impedance state.
9. Operation within the t_{RCD} (max) limit insures that t_{RAC} (max) can be met. t_{RCD} (max) is specified as a reference point only; if t_{RCD} is greater than the specified t_{RCD} (max) limit, access time is controlled exclusively by t_{CAC} or t_{AA}.
10. t_{RCD} (min) = t_{RAH} (min) + 2t_T + t_{ASC} (min).
11. Operation within the t_{RAD} (max) limit insures that t_{RAC} (max) can be met. t_{RAD} (max) is specified as a reference point only; if t_{RAD} is greater than the specified t_{RAD} (max) limit, access time is exclusively controlled by t_{CAC} or t_{AA}.
12. Either t_{RRH} or t_{RCH} must be specified for a read cycle.
13. t_{WCS}, t_{CWD}, t_{RWD}, and t_{AWD} are non restrictive operating parameters. They are included in the Data Sheet as Electrical characteristics only.
14. t_{CPA} is access time from the selection of a new column address (that is caused by changing CAS from "L" to "H").

7

TIMING DIAGRAMS

READ CYCLE

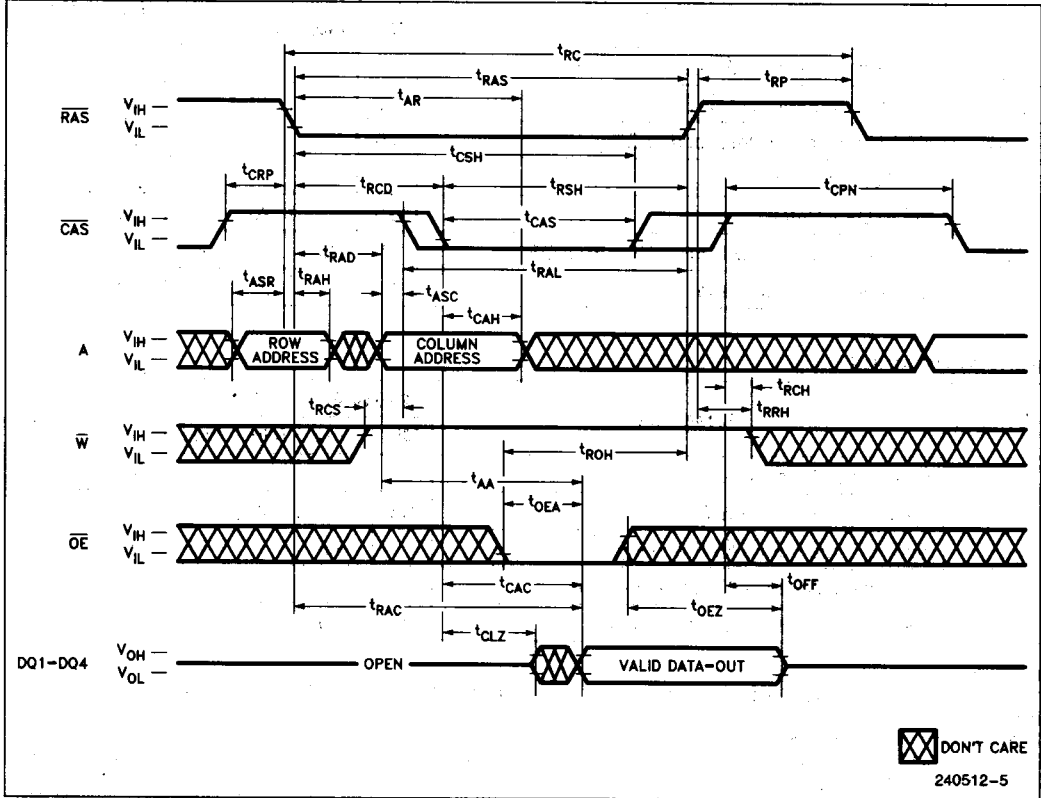

TIMING DIAGRAMS (Continued)

WRITE CYCLE (EARLY WRITE)

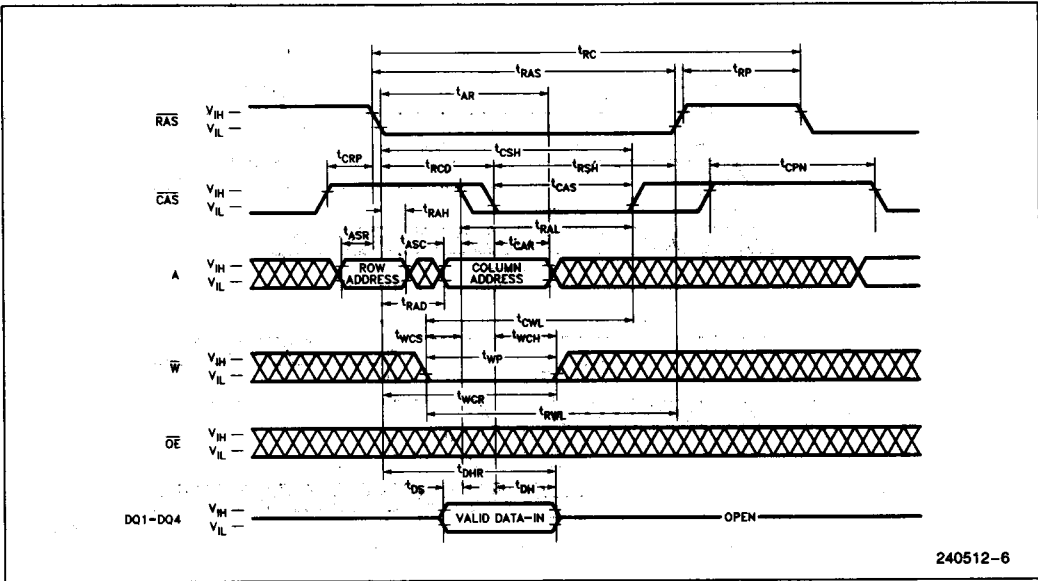

WRITE CYCLE (\overline{OE} CONTROLLED WRITE)

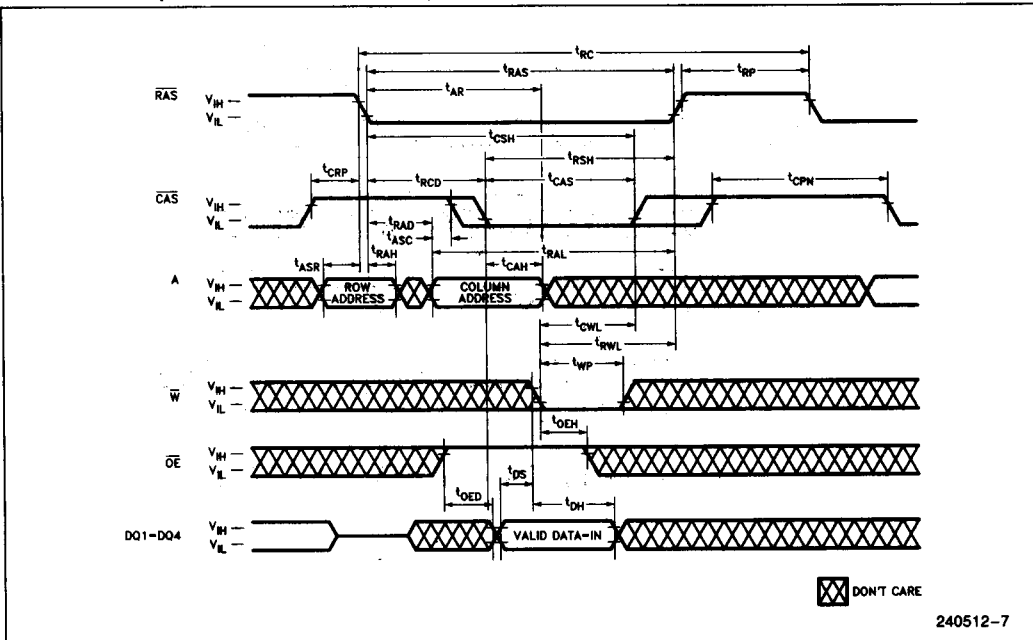

TIMING DIAGRAMS (Continued)

RAS-ONLY REFRESH CYCLE

Note: \overline{W} , \overline{OE} = Don't care

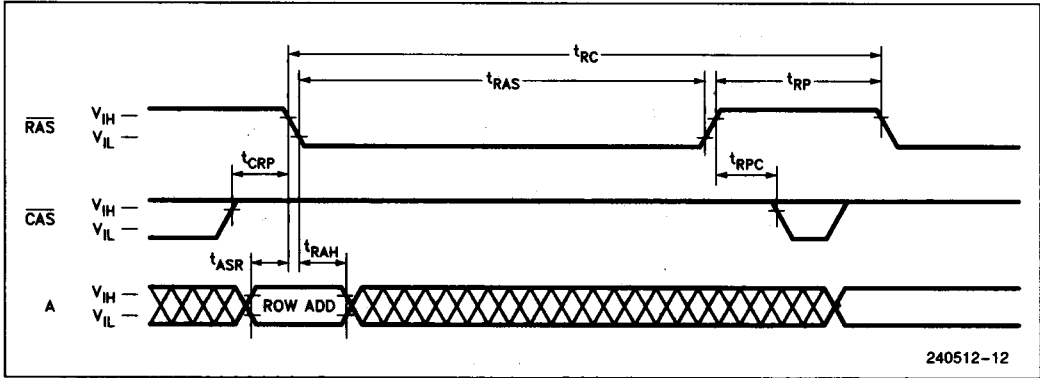

CAS-BEFORE-RAS REFRESH CYCLE

Note: \overline{W} , \overline{OE} , A = Don't care

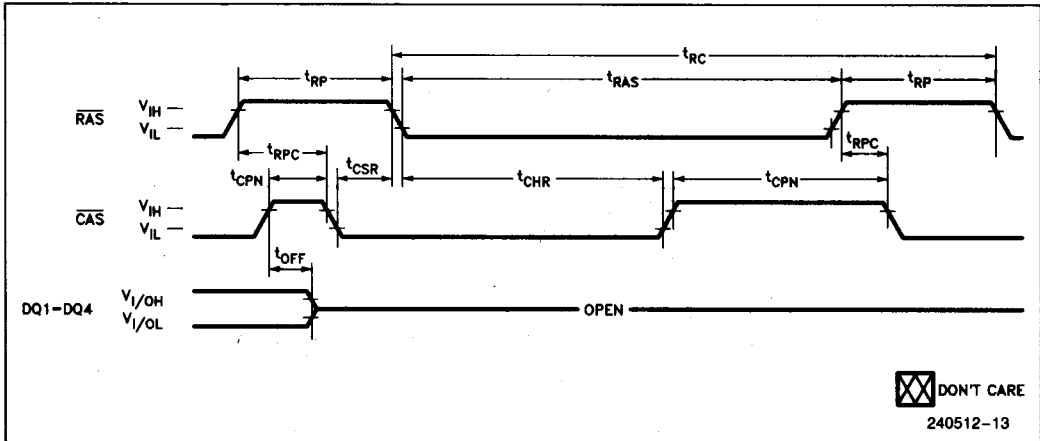

TIMING DIAGRAMS (Continued)

HIDDEN REFRESH CYCLE (READ)

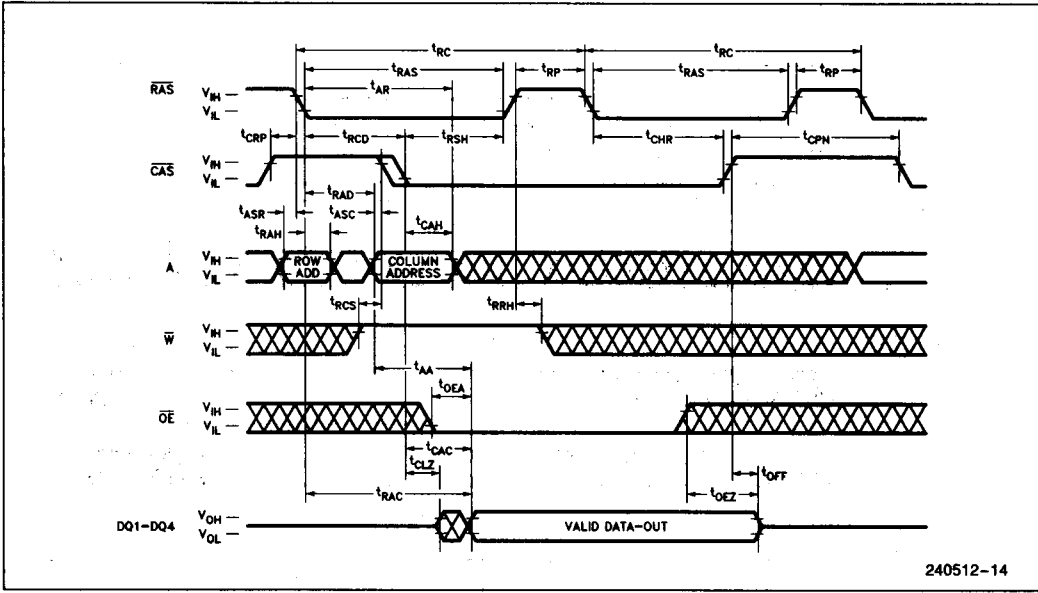

HIDDEN REFRESH CYCLE (WRITE)

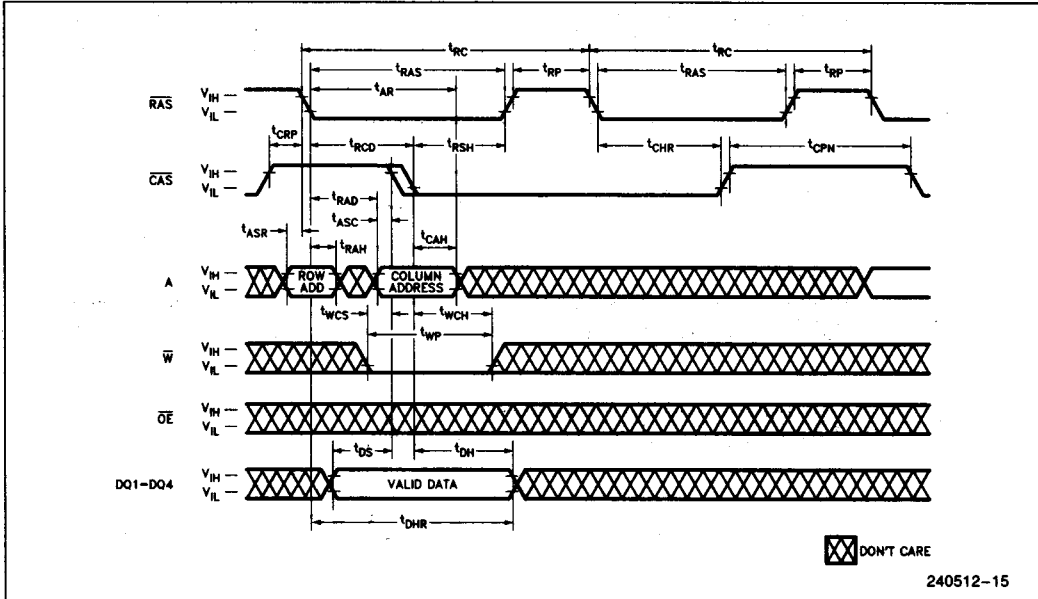

7

TIMING DIAGRAMS (Continued)

CAS-BEFORE-RAS REFRESH COUNTER TEST CYCLE

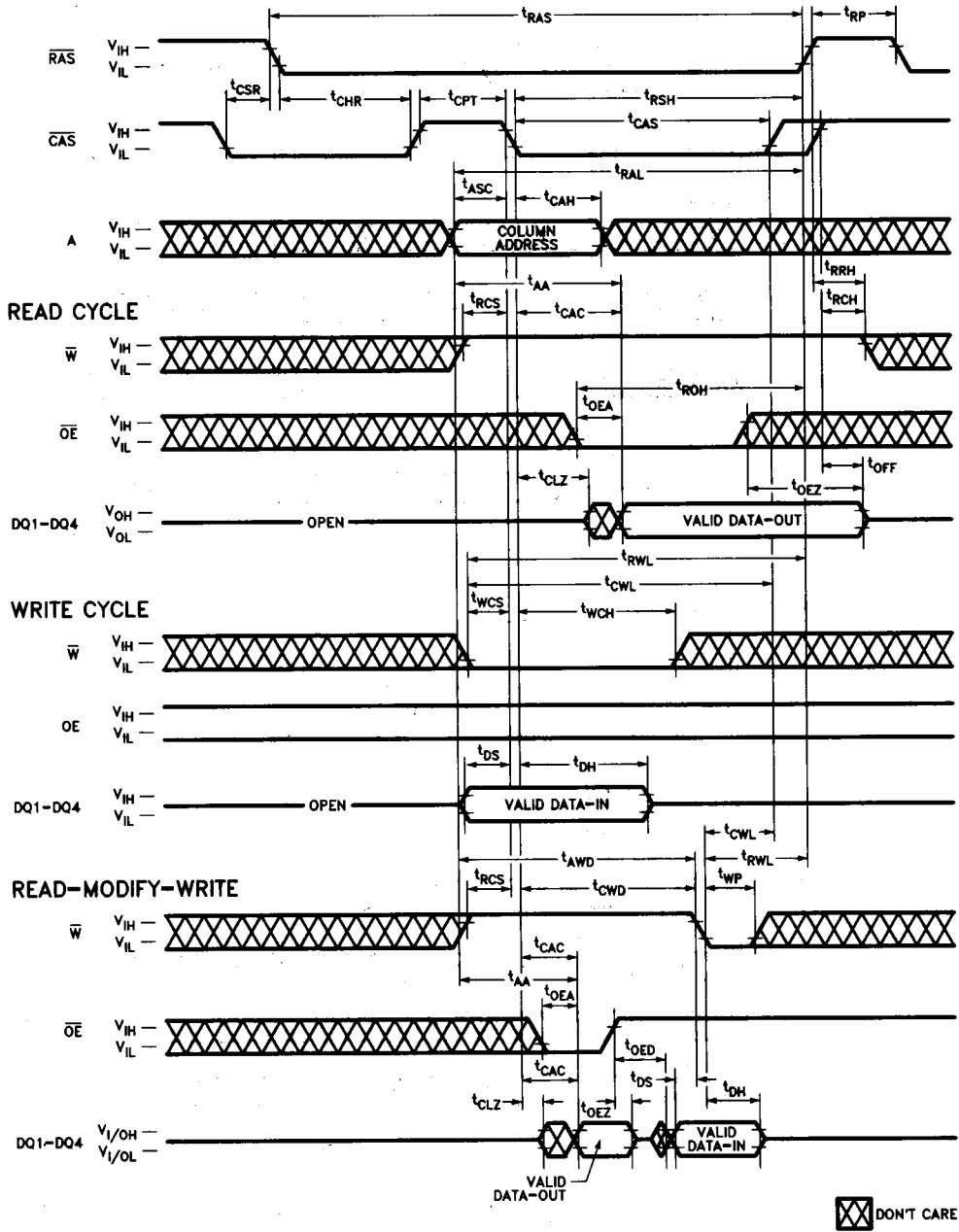

21014 OPERATION

Device Operation

The 21014 contains 1,048,576 memory locations organized as 262,144 four-bit words. Eighteen address bits are required to address a particular 4-bit word in the memory array. Since the 21014 has only 9 address input pins, time multiplexed addressing is used to input 9 row and 9 column addresses. The multiplexing is controlled by the timing relationship between the row address strobe ($\overline{\text{RAS}}$), the column address strobe ($\overline{\text{CAS}}$) and the valid address inputs.

Operation of the 21014 begins by strobing in a valid row address with $\overline{\text{RAS}}$ while $\overline{\text{CAS}}$ remains high. Then the address on the 9 address input pins is changed from a row address to a column address and is strobed in by $\overline{\text{CAS}}$. This is the beginning of any 21014 cycle in which a memory location is accessed. The specific type of cycle is determined by the state of the write enable pin and various timing relationships. The cycle is terminated when both $\overline{\text{RAS}}$ and $\overline{\text{CAS}}$ have returned to the high state. Another cycle can be initiated after $\overline{\text{RAS}}$ remains high long enough to satisfy the $\overline{\text{RAS}}$ precharge time (t_{RP}) requirement.

$\overline{\text{RAS}}$ and $\overline{\text{CAS}}$ Timing

The minimum $\overline{\text{RAS}}$ and $\overline{\text{CAS}}$ pulse widths are specified by t_{RAS} (min) and t_{CAS} (min) respectively. These minimum pulse widths must be satisfied for proper device operation and data integrity. Once a cycle is initiated by bringing $\overline{\text{RAS}}$ low, it must not be aborted prior to satisfying the minimum $\overline{\text{RAS}}$ and $\overline{\text{CAS}}$ pulse widths. In addition, a new cycle must not begin until the minimum $\overline{\text{RAS}}$ precharge time, t_{RP} , has been satisfied. Once a cycle begins, internal clocks and other circuits within the 21014 begin a complex sequence of events. If the sequence is broken by violating minimum timing requirements, loss of data integrity can occur.

Read

A read cycle is achieved by maintaining the write enable input ($\overline{\text{W}}$) high during a $\overline{\text{RAS}}/\overline{\text{CAS}}$ cycle. The access time is normally specified with respect to the falling edge of $\overline{\text{RAS}}$. But the access time also depends on the falling edge of $\overline{\text{CAS}}$ and on the valid column address transition.

If $\overline{\text{CAS}}$ goes low before t_{RCD} (max) and if the column address is valid before t_{RAD} (max) then the access time to valid data is specified by t_{RAC} (min). However, if $\overline{\text{CAS}}$ goes low after t_{RCD} (max) or if the column

address becomes valid after t_{RAD} (max), access is specified by t_{CAC} or t_{AA} . In order to achieve the minimum access time, t_{RAC} (min), it is necessary to meet both t_{RCD} (max) and t_{RAD} (max).

The 21014 has common data I/O pins. For this reason an output enable control input ($\overline{\text{OE}}$) has been provided so the output buffer can be precisely controlled. For data to appear at the outputs, $\overline{\text{OE}}$ must be low for the period of time defined by t_{OEA} and t_{OEZ} .

Write

The 21014 can perform early write and read-modify-write cycles. The difference between these cycles is in the state of data-out and is determined by the timing relationship between $\overline{\text{W}}$, $\overline{\text{OE}}$ and $\overline{\text{CAS}}$. In any type of write cycle data-in must be valid at or before the falling edge of $\overline{\text{W}}$ or $\overline{\text{CAS}}$, whichever is later.

Early Write: An early write cycle is performed by bringing $\overline{\text{W}}$ low before $\overline{\text{CAS}}$. The 4-bit wide data at the data input pins is written into the addressed memory cells. Throughout the early write cycle the outputs remain in the Hi-Z state. In the early write cycle the output buffers remain in the Hi-Z state regardless of the state of the $\overline{\text{OE}}$ input.

Read-Modify-Write: In this cycle, valid data from the addressed cells appears at the outputs before and during the time that data is being written into the same cell locations. This cycle is achieved by bringing $\overline{\text{W}}$ low after $\overline{\text{CAS}}$ and meeting the data sheet read-modify-write timing requirements. This output enable input ($\overline{\text{OE}}$) must be low during the time defined by t_{OEA} and t_{OEZ} for data to appear at the outputs. If t_{CWD} and t_{RWD} are not met the output may contain invalid data. Conforming to the $\overline{\text{OE}}$ timing requirements prevents bus contention on the 21014 DQ pins.

Data Output

The 21014 has tri-state output buffers which are controlled by $\overline{\text{CAS}}$ and $\overline{\text{OE}}$. When either $\overline{\text{CAS}}$ or $\overline{\text{OE}}$ is high (V_{IH}) the outputs are in the high impedance (Hi-Z) state. In any cycle in which valid data appears at the output the output goes into the low impedance state in a time specified by t_{CLZ} after the falling edge of $\overline{\text{CAS}}$. Invalid data may be present at the output during the time after t_{CLZ} and before the valid data appears at the output. The timing parameters t_{CAC} , t_{RAC} and t_{AA} specify when the valid data will be present at the output. This is true even if a new $\overline{\text{RAS}}$ cycle occurs (as in hidden refresh). Each of the 21014 operating cycles is listed below after the corresponding output state produced by the cycle.

Valid Output Data: Read, Read-Modify-Write, Hidden Refresh, Fast Page Mode Read, Fast Page Mode Read-Modify-Write.

High-Z Output State: Early Write, $\overline{\text{RAS}}$ -only Refresh, Fast Page Mode Write, $\overline{\text{CAS}}$ -only cycle.

Indeterminate Output State: Delayed Write (t_{CWD} or t_{RWD} are not met).

Refresh

The data in the 21014 is stored on a tiny capacitor within each memory cell. Due to leakage the data may leak off after a period of time. To maintain data integrity it is necessary to refresh each of the rows every 8 ms. Either a burst refresh or distributed refresh may be used. There are several ways to accomplish this.

$\overline{\text{RAS}}$ -Only Refresh: This is the most common method for performing refresh. It is performed by strobing in a row address with $\overline{\text{RAS}}$ while $\overline{\text{CAS}}$ remains high. This cycle must be repeated for each of the 512 row addresses, (A_0 - A_8).

$\overline{\text{CAS}}$ -before- $\overline{\text{RAS}}$ Refresh: The 21014 has $\overline{\text{CAS}}$ -before- $\overline{\text{RAS}}$ on-chip refresh capability that eliminates the need for external refresh addresses. If $\overline{\text{CAS}}$ is held low for the specified set up time (t_{CSR}) before $\overline{\text{RAS}}$ goes low, the on-chip refresh circuitry is enabled. An internal refresh operation automatically occurs. The refresh address is supplied by the on-chip refresh address counter which is then internally incremented in preparation for the next $\overline{\text{CAS}}$ -before- $\overline{\text{RAS}}$ refresh cycle.

Hidden Refresh: A hidden refresh cycle may be performed while maintaining the latest valid data at the output by extending the $\overline{\text{CAS}}$ active time and cycling $\overline{\text{RAS}}$. The 21014 hidden refresh cycle is actually a $\overline{\text{CAS}}$ -before- $\overline{\text{RAS}}$ refresh cycle within an extended read cycle. The refresh row address is provided by the on-chip refresh address counter.

Other Refresh Methods: It is also possible to refresh the 21014 by using read, write or read-modify-write cycles. Whenever a row is accessed, all the cells in that row are automatically refreshed. There are certain applications in which it might be advantageous to perform refresh in this manner but in general $\overline{\text{RAS}}$ -only or $\overline{\text{CAS}}$ -before- $\overline{\text{RAS}}$ refresh is the preferred method.

$\overline{\text{CAS}}$ -before- $\overline{\text{RAS}}$ Refresh Counter Test Cycle

A special timing sequence using the $\overline{\text{CAS}}$ -before- $\overline{\text{RAS}}$ refresh counter test cycle provides a convenient method of verifying the functionality of the $\overline{\text{CAS}}$ -before- $\overline{\text{RAS}}$ refresh activated circuitry. The cycle begins as a $\overline{\text{CAS}}$ -before- $\overline{\text{RAS}}$ refresh operation. Then, if $\overline{\text{CAS}}$ is brought high and then low again while $\overline{\text{RAS}}$ is held low, the read and write operations are enabled. In this mode, the row address bits A_0 through A_8 are supplied by the on-chip refresh counter.

Fast Page Mode

Fast page mode provides high speed read, write or read-modify-write access to all memory cells within a selected row. These cycles may be mixed in any order. A fast page mode cycle begins with a normal cycle. Then, while $\overline{\text{RAS}}$ is kept low to maintain the row address, $\overline{\text{CAS}}$ is cycled to strobe in additional column addresses. This eliminates the time required to set up and strobe sequential row addresses for the same page.

Power-Up

If $\overline{\text{RAS}} = V_{\text{SS}}$ during power-up, the 21014 could begin an active cycle. This condition results in higher than necessary current demands from the power supply during power-up. It is recommended that $\overline{\text{RAS}}$ and $\overline{\text{CAS}}$ track with V_{CC} during power-up or be held at a valid V_{IH} in order to minimize the power-up current.

An initial pause of 200 μs is required after power-up followed by 8 initialization cycles before proper device operation is assured. Eight initialization cycles are also required after any 8 ms period in which there are no $\overline{\text{RAS}}$ cycles. An initialization cycle is any cycle in which $\overline{\text{RAS}}$ is cycled.

Termination

The lines from the TTL driver circuits to the 21014 inputs act like unterminated transmission lines resulting in significant positive and negative overshoots at the inputs. To minimize overshoot it is advisable to terminate the input lines and to keep them as short as possible. Although either series or parallel termination may be used, series termination is

generally recommended since it is simple and draws no additional power. It consists of a resistor in series with the input line placed close to the 21014 input pin. The optimum value depends on the board layout. It must be determined experimentally and is usually in the range of 20Ω to 40Ω.

Board Layout

It is important to lay out the power and ground lines on memory boards in such a way that switching transient effects are minimized. The recommended methods are gridded power and ground lines or separate power and ground planes. The power and ground lines act like transmission lines to the high frequency transients generated by DRAMs. The impedance is minimized if all the power supply traces to all the DRAMs run both horizontally and vertically and are connected at each intersection or better yet if power and ground planes are used.

Address and control lines should be as short as possible to avoid skew. In boards with many DRAMs these lines should fan out from a central point like a fork or comb rather than being connected in a serpentine pattern. Also the control logic should be centrally located on large memory boards to facilitate the shortest possible address and control lines to all the DRAMs.

Decoupling

The importance of proper decoupling can not be overemphasized. Excessive transient noise or voltage droop on the V_{CC} line can cause loss of data integrity (soft errors). It is recommended that the total combined voltage changes over time in the V_{CC} to V_{SS} voltage (measured at the device pins) should not exceed 500 mV.

A high frequency 0.3 μF ceramic decoupling capacitor should be connected between the V_{CC} and ground pins of each 21014 using the shortest possible traces. These capacitors act as a low impedance shunt for the high frequency switching transients generated by the 21014 and they supply much of the current used by the 21014 during cycling.

In addition, a large tantalum capacitor with a value of 47 μF to 100 μF should be used for bulk decoupling to recharge the 0.3 μF capacitors between cycles, thereby reducing power line droop. The bulk decoupling capacitor should be placed near the point where the power traces meet the power grid or power plane. Even better results may be achieved by distributing more than one tantalum capacitor around the memory array.

PACKAGE DIMENSIONS

20-LEAD PLASTIC DUAL-IN-LINE PACKAGE (P) Units: Inches (millimeters)

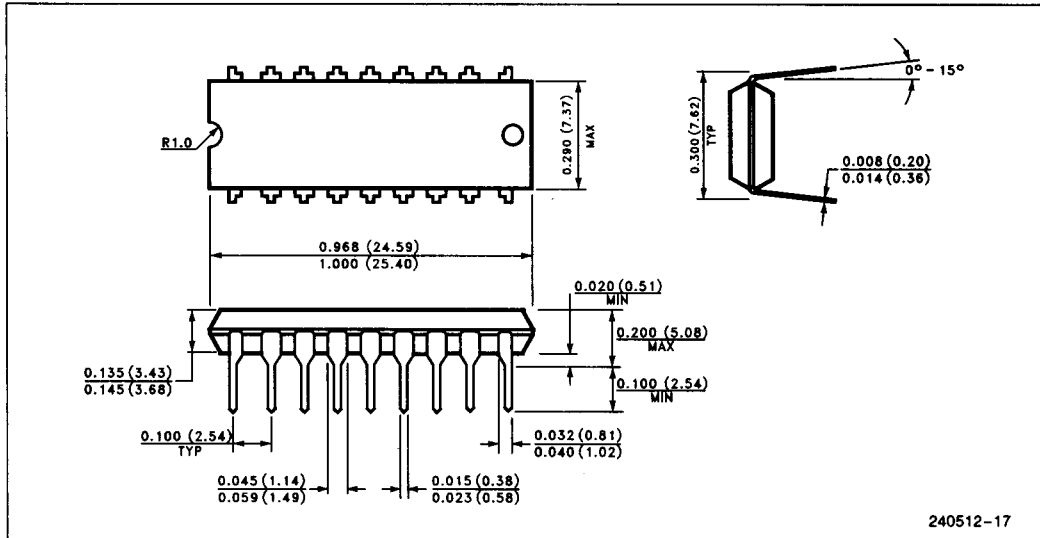

PACKAGE DIMENSIONS (Continued)

20-LEAD PLASTIC SMALL OUTLINE J-LEAD (T) Units: Inches (millimeters)

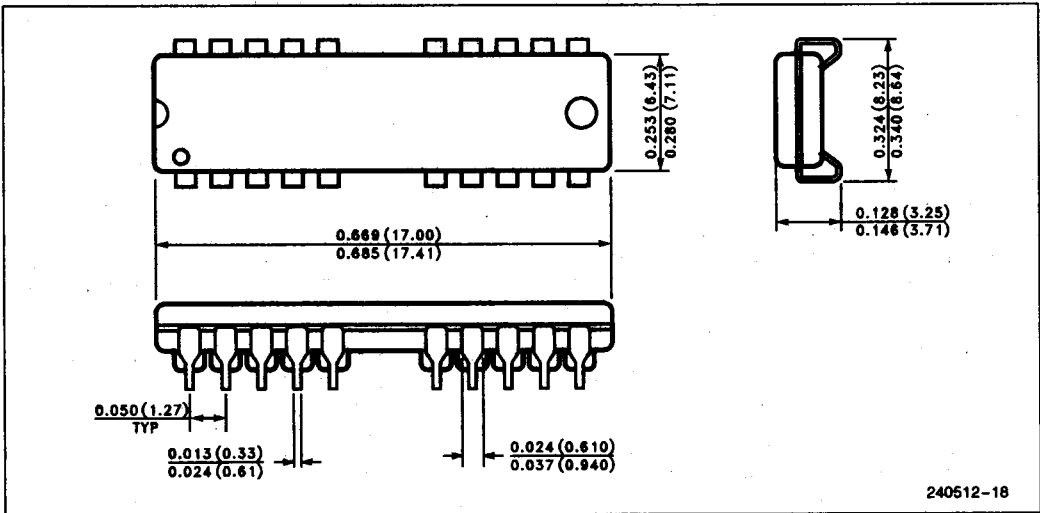

REVISION SUMMARY

The following list represents the key differences between version -004 and version -005 of the 21014 data sheet.

1. Updated AC Characteristics