

GaAs IC 4 Bit Digital Attenuator 2 dB LSB DC–2 GHz



AA320-25
(Previously AD320-25)*

Features

- Attenuation in 2 dB Steps to 30 dB with High Accuracy
- Low Cost SOIC-16 Plastic Package
- Low DC Power Consumption

Description

The AA320-25 is an IC FET digital attenuator consisting of four monolithic attenuators with LSB of 2 dB and a total attenuation of 30 dB with all attenuators connected.

This unit is a pin for pin replacement for the AT001D4-25 with improved RF performance extended to 2 GHz.

The AA320-25 is particularly well suited where high attenuation accuracy, low insertion loss and low intermodulation products are required. Typical applications include cellular, radio, wireless data, wireless local loop and other gain level control circuits.

SOIC-16

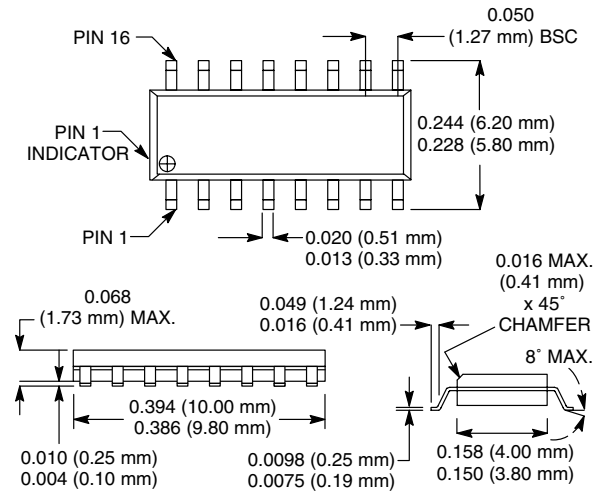

Electrical Specifications at 25°C (0, -5 V)

Parameter ¹	Frequency ²	Min.	Typ.	Max.	Unit
Insertion Loss ³	DC–0.1 GHz		1.2	1.4	dB
	DC–0.5 GHz		1.4	1.7	dB
	DC–1.0 GHz		1.5	1.8	dB
	DC–2.0 GHz		2.0	2.5	dB
Attenuation Range			30		dB
Attenuation Accuracy ⁴	DC–1.0 GHz	± (0.2 + 3% of Attenuation Setting in dB)			dB
	DC–2.0 GHz	± (0.3 + 3% of Attenuation Setting in dB)			dB
VSWR (I/O)	DC–1.0 GHz		1.4:1	1.6:1	
	DC–2.0 GHz		1.6:1	2.0:1	

Operating Characteristics at 25°C (0, -5 V)

Parameter	Condition	Frequency	Min.	Typ.	Max.	Unit
Switching Characteristics ⁵	Rise, Fall (10/90% or 90/10% RF) On, Off (50% CTL to 90/10% RF) Video Feedthru			15		ns
				25		ns
				25		mV
Input Power for 1 dB Compression		0.50–2.0 GHz		+28		dBm
		0.05 GHz		+22		dBm
Intermodulation Intercept Point (IP3)	For Two-tone Input Power +5 dBm	0.50–2.0 GHz		+48		dBm
		0.05 GHz		+38		dBm
Control Voltages	$V_{Low} = 0$ to -0.2 V @ 20 μ A Max. $V_{High} = -5$ V @ 50 μ A Typ. to -8 V @ 200 μ A Max.					

1. All measurements made in a 50 Ω system, unless otherwise specified.

2. DC = 300 kHz.

3. Insertion loss changes by 0.003 dB/°C.

4. Attenuation referenced to insertion loss.

5. Video feedthru measured with 1 ns risetime pulse and 500 MHz bandwidth.

*Due to conflict with another company's product numbering system, Alpha's attenuator products starting with the letters "AD" are being changed to "AA".

Typical Performance Data (0, -5 V)

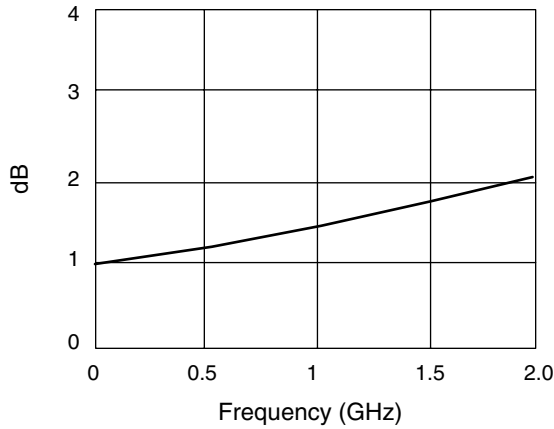

Insertion Loss vs. Frequency

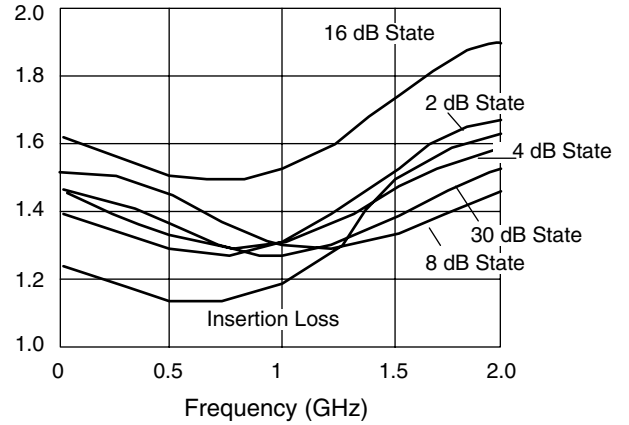

VSWR vs. Frequency

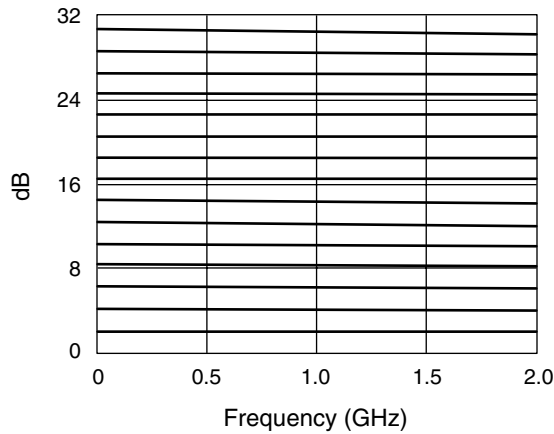

Attenuation vs. Frequency

Absolute Maximum Ratings

Characteristic	Value
RF Input Power	2 W > 500 MHz 0/-8 V 0.5 W @ 50 MHz 0/-8 V
Control Voltage	+0.2 V, -8 V
Operating Temperature	-40°C to +85°C
Storage Temperature	-65°C to +150°C

Note: Exceeding these parameters may cause irreversible damage.

Pin Out

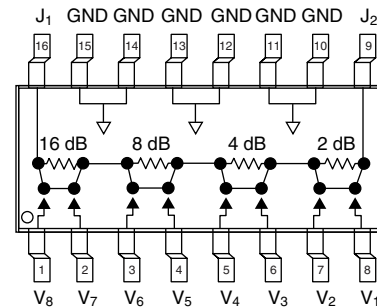

Truth Table

V ₁	V ₂	V ₃	V ₄	V ₅	V ₆	V ₇	V ₈	Attenuation J ₁ –J ₂
2 dB	4 dB	8 dB	16 dB					Reference I.L.
-5	0	-5	0	0	-5	-5	0	2 dB
-5	0	0	-5	0	-5	-5	0	4 dB
-5	0	-5	0	-5	0	-5	0	8 dB
-5	0	-5	0	0	-5	0	-5	16 dB
0	-5	0	-5	-5	0	0	-5	30 dB Max. Atten.