

# MC33689

## System Basis Chip with LIN Transceiver

Linear Regulators

### DESCRIPTION

The 33689 is an SPI-controlled System Basis Chip (SBC) combining many frequently used functions in an MCU-based system plus a Local Interconnect Network (LIN) transceiver. Applications include power window, mirror, and seat controls. The 33689 has a 5.0 V, 50 mA low dropout regulator with full protection and reporting features. The device provides full SPI-readable diagnostics and a selectable timing watchdog for detecting errant operation.

The LIN transceiver has waveshaping circuitry that can be disabled for higher data rates. One 50 mA and two 150 mA high-side switches with output protection are available to drive inductive or resistive loads. The 150 mA switches can be Pulse-Width Modulated.

Two high-voltage inputs are available for use in contact monitoring or as external wake-up inputs. A current sense operational amplifier is available for use in load current monitoring.

The 33689 has three operational modes:

- Normal (all functions available)
- Sleep (VDD OFF, wake-up via LIN bus or wake-up inputs)
- Stop (VDD ON, wake-up via MCU, LIN bus, or wake-up inputs)

The 33689 is compatible with LIN Protocol Specification 2.0.

### APPLICATIONS

- Aircraft Systems
- Automotive Systems
- Robotic Systems
- Farm Equipment
- Industrial Actuator Control
- Marine Applications

### 33689 SIMPLIFIED APPLICATION DIAGRAM

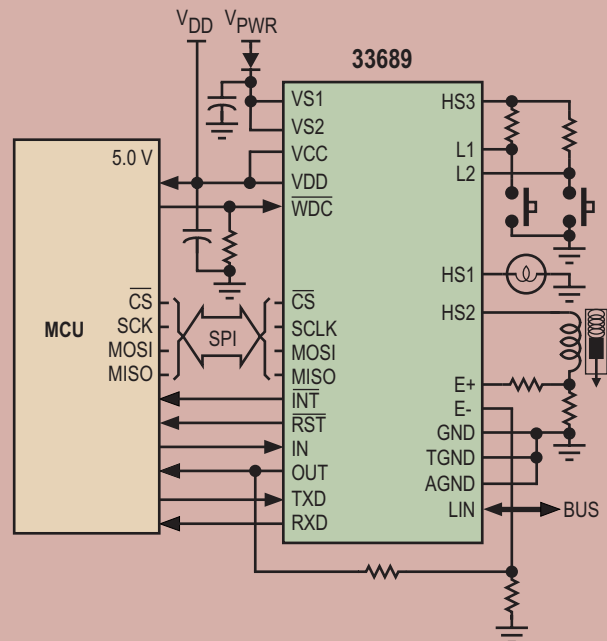

## FEATURES

- Full-duplex SPI interface at frequencies up to 4.0 MHz
- LIN transceiver capable of up to 100 kbps with waveshaping capability
- 5.0 V low dropout regulator full fault detection and protection
- One 50 mA and two 150 mA protected high-side switches
- Current sense operational amplifier
- Additional devices available for comparison in Analog Product Selector Guide - SG1002 and Automotive Product Selector Guide - SG187

PERFORMANCE	TYPICAL VALUES
Operating Voltage	5.5 V to 27 V
Data Rate	10 kbps to 100 kbps
Internal 5.0 V Regulator	50 mA
Max HS1 and HS2 Protected Current	150 mA
Sleep/Stop Current 33689D	35/60 $\mu$ A
Operating Temperature	$-40^{\circ}\text{C} \leq T_A \leq 125^{\circ}\text{C}$

## CUSTOMER BENEFITS

- Provides complete MCU power management solution with few components
- Low power stop mode regulator with monitoring
- Supports operation with input supply voltage down to 5.0 V
- Low power mode flexibility and wake-up options
- LIN and SPI interfaces
- Software watchdog function and external safe circuitry for automatic activation
- Two wake-up inputs for system use
- Reduced PC board space resulting in enhanced application reliability
- Freescale offers a complete line of compatible System Basis Chips with transceivers

### 33689 INTERNAL BLOCK DIAGRAM

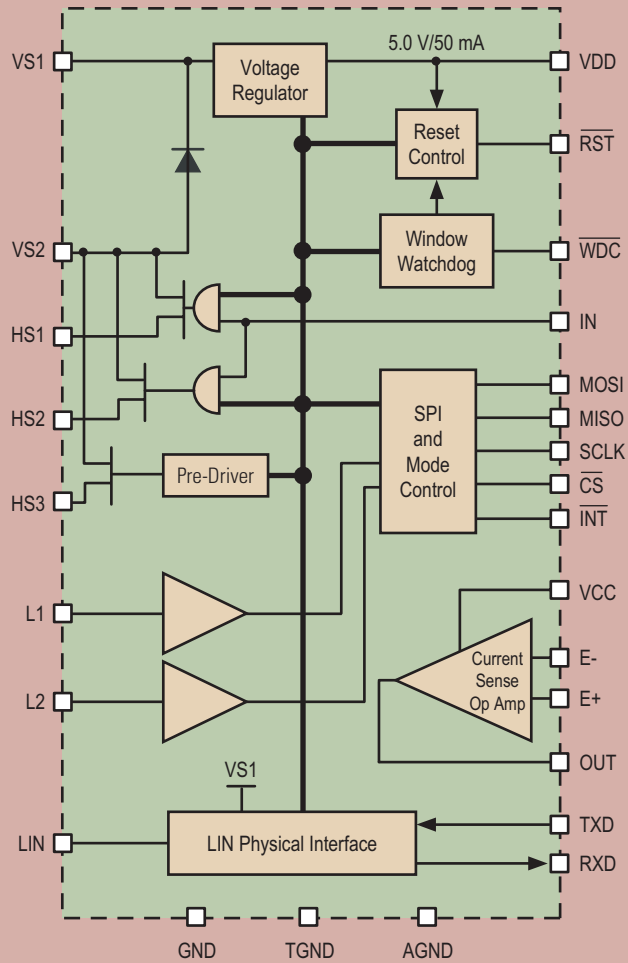

PROTECTION	DETECT	SHUT DOWN	LIMITING	STATUS REPORTING
VS1, VS2:				
Overvoltage	●			SPI
Undervoltage	●			SPI and INTERRUPT
VDD:				
Undervoltage	●			Reset
Overcurrent Limiting	●		●	
Overtemperature Pre-warning	●			SPI and INTERRUPT
Overtemperature Shutdown	●	●		
HS1, HS2, and HS3:				
Overcurrent	●		●	
Overtemperature	●	●		SPI and INTERRUPT
LIN BUS:				
Overtemperature	●	●		
Bus Short	●		●	



*Communicating*

*Protecting*

*Controlling*

#### QUESTIONS

- Are you using a LIN communication system?
- Do you need a LIN transceiver with microcontroller support features in a single package?
- Do you need a design solution for a LIN node capable of high-side PWM controlling loads in addition to providing power management functions for the microcontroller?
- Do you need a LIN transceiver, with watchdog and wake-up inputs in support of the microcontroller?

#### ORDERING INFORMATION

Device	Temperature Range (T <sub>A</sub> )	Package
**33689DDWB/R2	-40°C to 125°C	32 SOICW
**33689DEW/R2		

Data Sheet Order Number MC33689

\*\*Prefix Index:

PC = Engineering Samples; MC = Production

Contact Sales for Evaluation Kit Availability

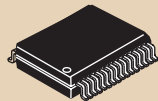

**32 Terminal SOICW**  
0.65 mm Pitch  
11.0 mm x 7.5 mm Body