

# 8-bit multiplying D/A converter

## MC1508-8/1408-8

### DESCRIPTION

The MC1508/MC1408 series of 8-bit monolithic digital-to-analog converters provide high-speed performance with low cost. They are designed for use where the output current is a linear product of an 8-bit digital word and an analog reference voltage

### FEATURES

- Fast settling time — 70ns (typ)
- Relative accuracy  $\pm 0.19\%$  (max error)
- Non-inverting digital inputs are TTL and CMOS compatible
- High-speed multiplying rate 4.0mA/ $\mu$ s (input slew)
- Output voltage swing +0.5V to -5.0V
- Standard supply voltages +5.0V and -5.0V to -15V
- Military qualifications pending

### APPLICATIONS

- Tracking A-to-D converters
- 2 1/2-digit panel meters and DVMs
- Waveform synthesis
- Sample-and-Hold
- Peak detector
- Programmable gain and attenuation
- CRT character generation
- Audio digitizing and decoding
- Programmable power supplies
- Analog-digital multiplication
- Digital-digital multiplication
- Analog-digital division
- Digital addition and subtraction
- Speech compression and expansion
- Stepping motor drive modems
- Servo motor and pen drivers

### PIN CONFIGURATIONS

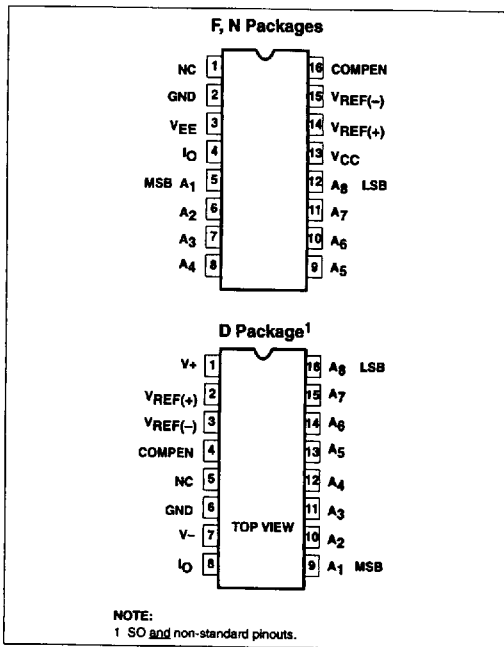

### ORDERING INFORMATION

DESCRIPTION	TEMPERATURE RANGE	ORDER CODE	DWG #
16-Pin Ceramic Dual In-Line Package (CERDIP)	-55 to +125°C	MC1508-8F	0582B
16-Pin Ceramic Dual In-Line Package (CERDIP)	0 to +70°C	MC1408-8F	0582B
16-Pin Plastic Dual In-Line Package (DIP)	0 to +70°C	MC1408-8N	0406C
16-Pin Small Outline (SO) Package	0 to +70°C	MC1408-8D	0005D

# 8-bit multiplying D/A converter

MC1508-8/1408-8

## BLOCK DIAGRAM

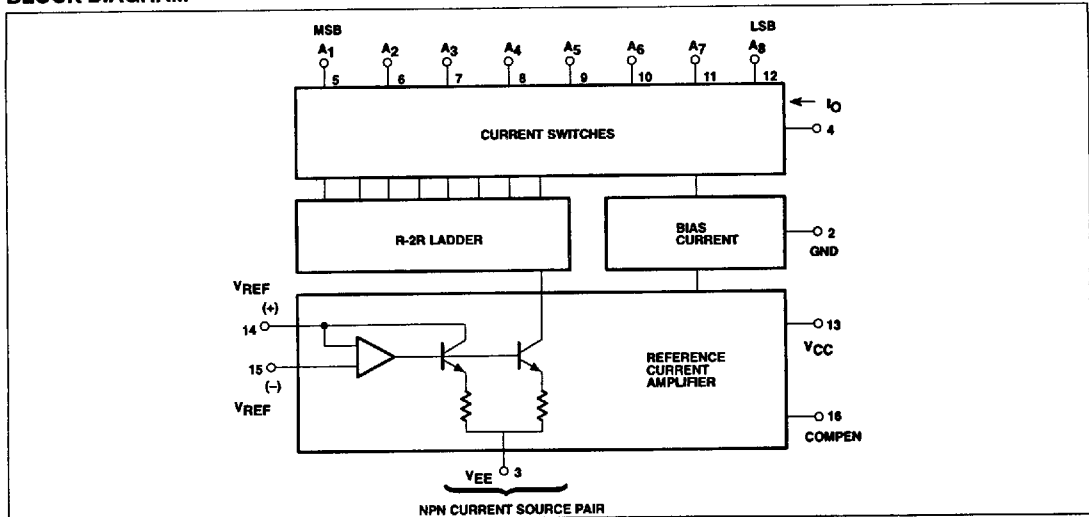

### CIRCUIT DESCRIPTION

The MC1508/MC1408 consists of a reference current amplifier, an R-2R ladder, and 8 high-speed current switches. For many applications, only a reference resistor and reference voltage need be added.

The switches are non-inverting in operation; therefore, a high state on the input turns on the specified output current component.

The switch uses current steering for high speed, and a termination amplifier consisting of an active load gain stage with unity gain

feedback. The termination amplifier holds the parasitic capacitance of the ladder at a constant voltage during switching, and provides a low impedance termination of equal voltage for all legs of the ladder.

The R-2R ladder divides the reference amplifier current into binary-related components, which are fed to the remainder current which is equal to the least significant bit. This current is shunted to ground, and the maximum output current is 255/256 of the reference amplifier current, or 1.992mA for a 2.0mA reference amplifier current if the NPN current source pair is perfectly matched.

### ABSOLUTE MAXIMUM RATINGS

SYMBOL	PARAMETER	RATING	UNIT
V <sub>CC</sub>	Positive power supply voltage	+5.5	V
V <sub>EE</sub>	Negative power supply voltage	-16.5	V
V <sub>5 - V<sub>12</sub></sub>	Digital input voltage	0 to V <sub>CC</sub>	V
V <sub>O</sub>	Applied output voltage	-5.2 to +18	V
I <sub>14</sub>	Reference current	5.0	mA
V <sub>14, V<sub>15</sub></sub>	Reference amplifier inputs	V <sub>EE</sub> to V <sub>CC</sub>	
P <sub>D</sub>	Maximum power dissipation, T <sub>A</sub> = 25°C (still-air) <sup>1</sup>		
	F package	1190	mW
	N package	1450	mW
	D package	1080	mW
T <sub>SOLD</sub>	Lead soldering temperature (10 sec)	300	°C
T <sub>A</sub>	Operating temperature range	300	°C
	MC1508	-55 to +125	°C
	MC1408	0 to +75	°C
T <sub>STG</sub>	Storage temperature range	-65 to +150	°C

#### NOTES:

1. Derate above 25°C, at the following rates: F package at 9.5mW/°C; N package at 11.6mW/°C; D package at 8.6mW/°C

## 8-bit multiplying D/A converter

MC1508-8/1408-8

## DC ELECTRICAL CHARACTERISTICS

Pin 3 must be 3V more negative than the potential to which R<sub>15</sub> is returned. V<sub>CC</sub> = +5.0V<sub>DC</sub>, V<sub>EE</sub> = -15V<sub>DC</sub>, V<sub>REF</sub>/R<sub>14</sub> = 2.0mA unless otherwise specified. MC1508: T<sub>A</sub> = -55°C to 125°C. MC1408: T<sub>A</sub> = 0°C to 75°C, unless otherwise noted.

SYMBOL	PARAMETER	TEST CONDITIONS	MC1508-8			MC1408-8			UNIT
			Min	Typ	Max	Min	Typ	Max	
E <sub>r</sub>	Relative accuracy	Error relative to full-scale I <sub>O</sub> , Figure 3			±0.19			±0.19	%
t <sub>s</sub>	Settling time <sup>1</sup>	To within 1/2 LSB, includes t <sub>PLH</sub> , T <sub>A</sub> = +25°C, Figure 4		70			70		ns
t <sub>PLH</sub> t <sub>PHL</sub>	Propagation delay time Low-to-High High-to-Low	T <sub>A</sub> = +25°C, Figure 4		35	100		35	100	ns
TCI <sub>O</sub>	Output full-scale current drift			-20			-20		ppm/°C
V <sub>IH</sub> V <sub>IL</sub>	Digital input logic level (MSB) High Low	Figure 5	2.0		0.8	2.0		0.8	V <sub>DC</sub>
I <sub>IH</sub> I <sub>IL</sub>	Digital input current (MSB) High Low	Figure 5 V <sub>IH</sub> = 5.0V V <sub>IL</sub> = 0.8V		0 -0.4	0.04 -0.8		0 -0.4	0.04 -0.8	mA
I <sub>15</sub>	Reference input bias current	Pin 15, Figure 5		-1.0	-5.0		-1.0	-5.0	μA
I <sub>OR</sub>	Output current range	Figure 5 V <sub>EE</sub> = -5.0V V <sub>EE</sub> = -7.0V to -15V	0 0	2.0 2.0	2.1 4.2	0 0	2.0 2.0	2.1 4.2	mA
I <sub>O</sub>	Output current	Figure 5 V <sub>REF</sub> = 2.000V, R <sub>14</sub> = 1000Ω All bits low	1.9	1.99	2.1	1.9	1.99	2.1	mA
I <sub>O(min)</sub>	Off-state			0	4.0		0	4.0	μA
V <sub>O</sub>	Output voltage compliance	E <sub>r</sub> ≤ 0.19% at T <sub>A</sub> = +25°C, Figure 5 V <sub>EE</sub> = -5V  V <sub>EE</sub> below -10V		-0.6 +10 -5.5, +10	-0.55, +0.5 -5.0, +0.5		-0.6 +10 -5.5, +10	-0.55, +0.5 -5.0, +0.5	V <sub>DC</sub>
SRI <sub>REF</sub>	Reference current slew rate	Figure 6		8.0			8.0		mA/μs
PSRR(-)	Output current power supply sensitivity	I <sub>REF</sub> = 1mA		0.5	2.7		0.5	2.7	μA/V
I <sub>CC</sub> I <sub>EE</sub>	Power supply current Positive Negative	All bits low, Figure 5		+2.5 -6.5	+22 -13		+2.5 -6.5	+22 -13	mA
V <sub>CCR</sub> V <sub>VEER</sub>	Power supply voltage range Positive Negative	T <sub>A</sub> = +25°C, Figure 5	+4.5 -4.5	+5.0 -15	+5.5 -16.5	+4.5 -4.5	+5.0 -15	+5.5 -16.5	V <sub>DC</sub>
P <sub>D</sub>	Power dissipation	All bits low, Figure 5 V <sub>EE</sub> = -5.0V <sub>DC</sub> V <sub>EE</sub> = -15.0V <sub>DC</sub>		34 110	170 305		34 110	170 305	mW

## NOTES:

1. All bits switched.

## 8-bit multiplying D/A converter

MC1508-8/1408-8

## TYPICAL PERFORMANCE CHARACTERISTICS

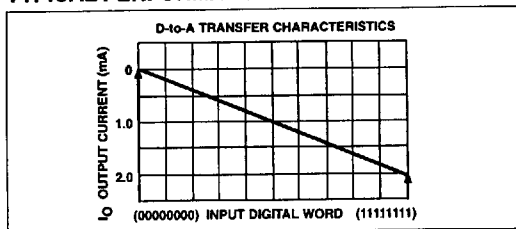

## FUNCTIONAL DESCRIPTION

## Reference Amplifier Drive and Compensation

The reference amplifier input current must always flow into Pin 14, regardless of the setup method or reference supply voltage polarity.

Connections for a positive reference voltage are shown in Figure 1. The reference voltage source supplies the full reference current. For bipolar reference signals, as in the multiplying mode,  $R_{15}$  can be tied to a negative voltage corresponding to the minimum input level.  $R_{15}$  may be eliminated and Pin 15 grounded, with only a small sacrifice in accuracy and temperature drift.

The compensation capacitor value must be increased with increasing values of  $R_{14}$  to maintain proper phase margin. For  $R_{14}$  values of 1.0, 2.5, and 5.0k $\Omega$ , minimum capacitor values are 15, 37, and 75pF. The capacitor may be tied to either  $V_{EE}$  or ground, but using  $V_{EE}$  increases negative supply rejection. (Fluctuations in the negative supply have more effect on accuracy than do any changes in the positive supply.)

A negative reference voltage may be used if  $R_{14}$  is grounded and the reference voltage is applied to  $R_{15}$ , as shown in Figure 2. A high input impedance is the main advantage of this method. The negative reference voltage must be at least 3.0V above the  $V_{EE}$  supply. Bipolar input signals may be handled by connecting  $R_{14}$  to a positive reference voltage equal to the peak positive input level at Pin 15.

Capacitive bypass to ground is recommended when a DC reference voltage is used. The 5.0V logic supply is not recommended as a reference voltage, but if a well regulated 5.0V supply which drives logic is to be used as the reference,  $R_{14}$  should be formed of two series resistors and the junction of the two resistors bypassed with 0.1 $\mu$ F to ground. For reference voltages greater than 5.0V, a clamp diode is recommended between Pin 14 and ground.

If Pin 14 is driven by a high impedance such as a transistor current source, none of the above compensation methods apply and the amplifier must be heavily compensated, decreasing the overall bandwidth.

## Output Voltage Range

The voltage at Pin 4 must always be at least 4.5V more positive than the voltage of the negative supply (Pin 3) when the reference current is 2mA or less, and at least 8V more positive than the negative supply when the reference current is between 2mA and 4mA. This is necessary to avoid saturation of the output transistors, which would cause serious degradation of accuracy.

Philips Semiconductors MC1508/MC1408 does not need a range control because the design extends the compliance range down to

4.5V (or 8V — see above) above the negative supply voltage without significant degradation of accuracy. Philips Semiconductors MC1508/MC1408 can be used in sockets designed for other manufacturers' MC1508/MC1408 without circuit modification.

## Output Current Range

Any time the full-scale current exceeds 2mA, the negative supply must be at least 8V more negative than the output voltage. This is due to the increased internal voltage drops between the negative supply and the outputs with higher reference currents.

## Accuracy

Absolute accuracy is the measure of each output current level with respect to its intended value, and is dependent upon relative accuracy, full-scale accuracy and full-scale current drift. Relative accuracy is the measure of each output current level as a fraction of the full-scale current after zero-scale current has been nulled out. The relative accuracy of the MC1508/MC1408 is essentially constant over the operating temperature range because of the excellent temperature tracking of the monolithic resistor ladder. The reference current may drift with temperature, causing a change in the absolute accuracy of output current; however, the MC1508/MC1408 has a very low full-scale current drift over the operating temperature range.

The MC1508/MC1408 series is guaranteed accurate to within  $\pm 1/2$ LSB at +25°C at a full-scale output current of 1.99mA. The relative accuracy test circuit is shown in Figure 3. The 12-bit converter is calibrated to a full-scale output current of 1.99219mA; then the MC1508/MC1408's full-scale current is trimmed to the same value with  $R_{14}$  so that a zero value appears at the error amplifier output. The counter is activated and the error band may be displayed on the oscilloscope, detected by comparators, or stored in a peak detector.

Two 8-bit D-to-A converters may not be used to construct a 16-bit accurate D-to-A converter. 16-bit accuracy implies a total of  $\pm 1/2$  part in 65,536, or  $\pm 0.00076\%$ , which is much more accurate than the  $\pm 0.19\%$  specification of the MC1508/MC1408.

## Monotonicity

A monotonic converter is one which always provides an analog output greater than or equal to the preceding value for a corresponding increment in the digital input code. The MC1508/MC1408 is monotonic for all values of reference current above 0.5mA. The recommended range for operation is a DC reference current between 0.5mA and 4.0mA.

## Settling Time

The worst case switching condition occurs when all bits are switched on, which corresponds to a low-to-high transition for all input bits. This time is typically 70ns for settling to within 1/2LSB for 8-bit accuracy. This time applies when  $R_L < 500\Omega$  and  $C_O < 25$ pF. The slowest single switch is the least significant bit, which typically turns on and settles in 65ns. In applications where the D-to-A converter functions in a positive going ramp mode, the worst-case condition does not occur and settling times less than 70ns may be realized.

Extra care must be taken in board layout since this usually is the dominant factor in satisfactory test results when measuring settling time. Short leads, 100 $\mu$ F supply bypassing for low frequencies, minimum scope lead length, good ground planes, and avoidance of ground loops are all mandatory.

# 8-bit multiplying D/A converter

MC1508-8/1408-8

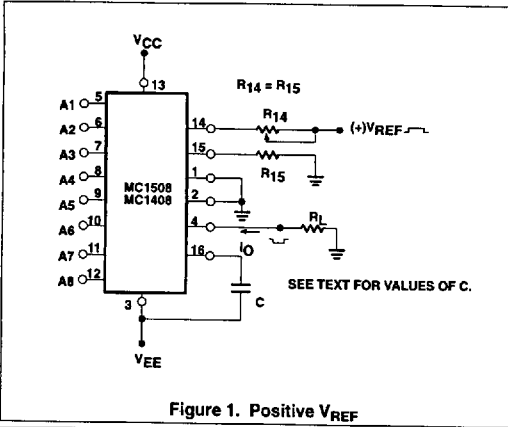

Figure 1. Positive  $V_{REF}$

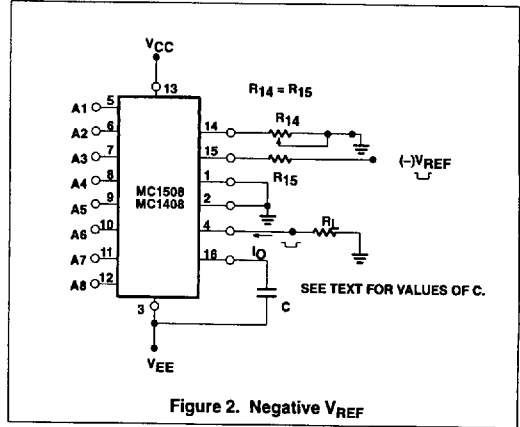

Figure 2. Negative  $V_{REF}$

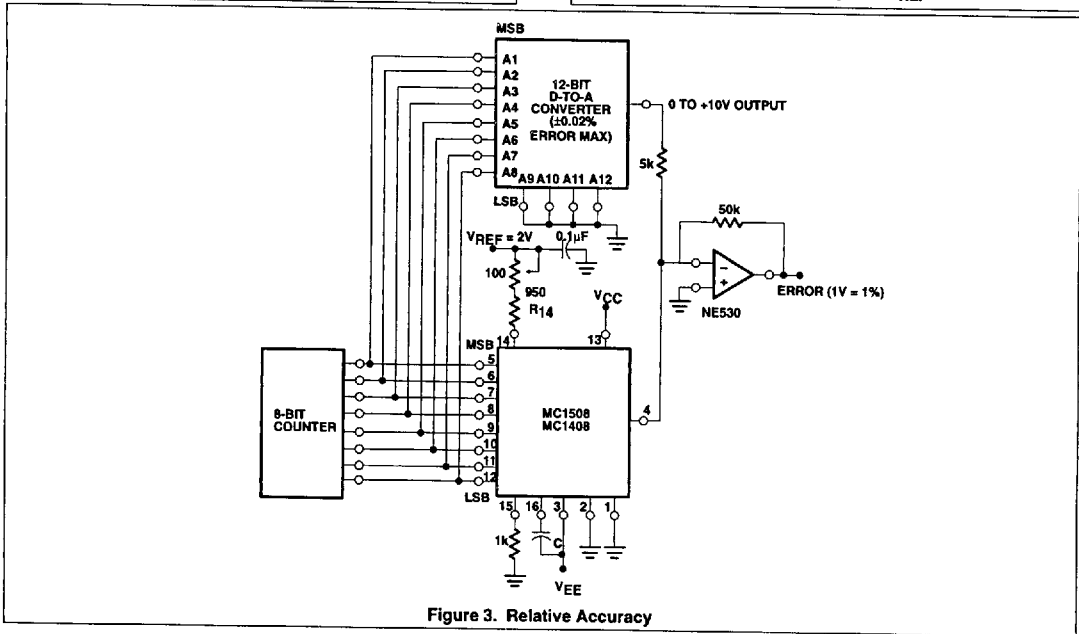

Figure 3. Relative Accuracy

# 8-bit multiplying D/A converter

MC1508-8/1408-8

