

Voice Coil Motor Driver

Functions

- Input amp.
- BTL output amp.
- Current sense amp.
- Current limiter
- Input selector with disable
- OTSD (Over Temperature Shut Down)

Features

- Selectable output current
 HA13470 2.5A Max.
- Easy to retract with control 2 inputs
- No cross-over distortion
- Low saturation voltage
- Externally adjustable current limiter
- Few—external components
- Wide operating voltage range

Block Diagram

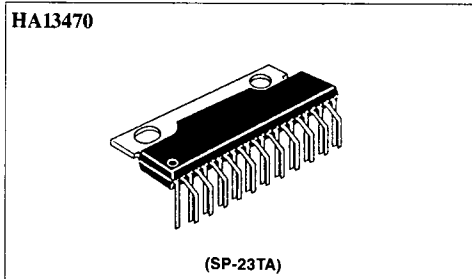
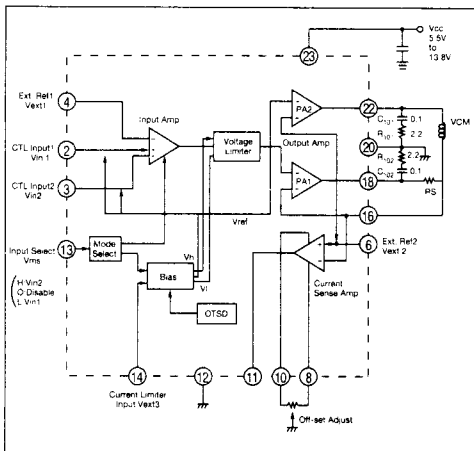

Ordering Information

Type No.	Package
HA13470	SP-23TA

Pin Assignment

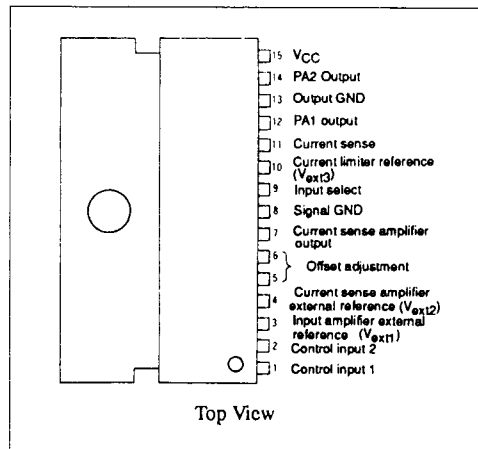

External Components

Parts No.	Recommended Value	Purpose	Note
R101, R102	2.2Ω	For Stability	
VR1	10KΩ	Offset Adjust	
Rs	1.0Ω	Current Sense	1
C101, C102	0.1μF	For Stability	
C102	≥ 0.1μF	Power Supply Bypass	

Note: 1. Use a reactance free resistance.

Current Voltage Conversion Characteristics

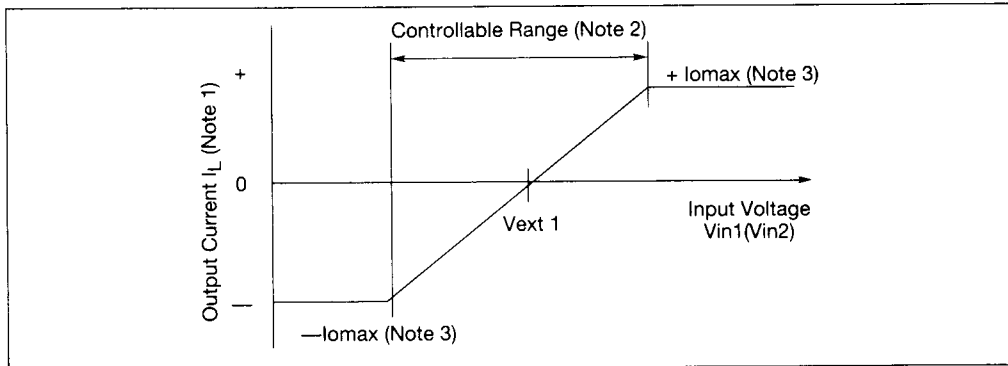

- Notes: 1. Output current ⊕ means source current from Pin ⑩ and ⊖ means sink current.
 2. In this range the relation between output current and input voltage can be described as follows (under not saturated condition at output).

$$I_o = \frac{GV_1 (V_{in} - V_{ext1})}{R_s}$$

Where $GV_1 = 2$ typ. (internal constant)

3. The relation between $+ I_{omax}$ and V_{ext3} , and between $- I_{omax}$ and V_{ext3} , can be described as follows respectively.

$$+ I_{omax} = \frac{GV_3 V_{ext3}}{R_s}, \quad - I_{omax} = - \frac{GV_3 V_{ext3}}{R_s}$$

Where $GV_3 = 0.5$ typ. (internal constant)

Absolute Maximum Ratings ($T_a = 25^\circ\text{C}$)

Item	Symbol	HA13470	Unit	Note
Supply Voltage	VCC	15	V	1
Output Peak Current	I _{opeak}	2.5	A	2
Output Constant Current	I _o	1.67	A	
Input Voltage	V _{in}	-0.5 ~ VCC	V	
Power Dissipation	P ₁	10	W	3
Junction Temperature	T _j	150	°C	1
Storage Temperature	T _{stg}	-55 ~ +125	°C	

The absolute maximum ratings are limiting values, to be applied individually, beyond which the device may be permanently damaged. Functional operation under any of these conditions is not guaranteed. Exposing a circuit to its absolute maximum rating for extended periods of time may affect the device's reliability.

- Notes: 1. The recommended operating supply voltage range is: $V_{CC} = 5.5$ to 13.8V , $T_{jopr} = 0 \sim +125^\circ\text{C}$
 2. $t \leq 20\text{msec}$.
 3. The value is at $T_c = 120^\circ\text{C}$. Thermal resistance show as follows: $\text{H}_j - c \leq 5^\circ\text{C/W}$, $\text{H}_j - a \leq 40^\circ\text{C/W}$



Electrical Characteristics (Ta = 25°C, VCC = 12V, RS = 1.0Ω, RL = 4Ω)

Item	Symbol	Test Condition	min.	typ.	max.	Unit	Applicable Terminal	Note			
Quiescent Current	I _{CCO}	V _{ms} = Open	—	—	—	mA	23				
	I _{CC}	V _{ms} = 0.8V	—	30	.50	mA					
Input Select	Input Current	I _{ms}	V _{ms} = 0 ~ 5V	—	—	±0.5	mA	13			
	Select 1 Voltage	V _{ms1}		—	—	0.8	V				
	Disable Voltage	V _{msm}		2	—	3	V				
	Select 2 Voltage	V _{msH}		4.2	—	—	V				
Input Amp.	Input Current	I _{in}	V _{in} = 4 ~ 8V	—	—	±30	μA	2-4			
	Common Mode Input Voltage	V _{ext1}		4	—	8	V				
	Offset Voltage	V _{IO1}	V _{sens} = 0	—	—	±10	mV		2-4	1	
Output Amp.	Saturation Voltage	V _{sat}	I _O = 0.55A (0.33A)	—	1.4	1.8	V	18, 22	2		
			I _O = 1.67A (1.0A)	—	2.0	2.8	V				
Input Amp. to Output Amp.	Voltage Gain	GV ₁	f _{in} = 1KHz	—	6	—	dB	16, 18	1		
	Gain Band Width	BW ₁	ΔG _{v1} = -3dB	—	—	—	KHz				
	Phase Delay	Δφ	f _{in} = KHz	—	—	—	deg.				
	Total Harmonic Distortion	THD	f _{in} = 1KHz I _O = 100mArms	—	—	2	%				
Current Limiter	Input Current	I _{ext3}	V _{ext3} = 0 ~ 5V	—	—	±10	μA	14			
	Offset Voltage	V _{IO3}	V _{SCNS} = ±10mV	—	—	±50	mV				
	Setting Gain	GV ₃	V _{ext3} < 2V	—	-6	—	dB			14	3
	Gain Difference	ΔGV ₃		—	—	±1	dB				
Current Sense Amp.	Common Mode Input Voltage	V _{ext2}		4	—	8	V	6			
	Offset Voltage	V _{IO2}		—	—	±10	mV			16, 18	
	Output Voltage Swing	V _O		8	—	—	V _{PP}			11	
	Gain Band Width	BW ₂	G _v = 0dB	—	1.0	—	MHz				
OTSD	Shut Down Temperature	T _{sd}		125	150	—	°C				

Notes: 1. See Figure 1. For Offset Voltage (V_{IO1}) and by can be calibrated as.

$$GV_1 = 20 \log_{10} \frac{\Delta V_{sens}}{\Delta V_{in}} \text{ (dB)}$$

2. Specified by the sum of upper and lower saturation voltage
3. See Figure 2.

$$GV_0 = 20 \log_{10} \frac{\Delta V_{sens}}{\Delta V_{ext3}} \text{ (dB)}$$

The Waveform of HA13470 $R_S = 0.5\Omega$, $R_L = 4\Omega$, $L = 1.0\text{mH}$

(1) $f_{in} = 1\text{KHz}$, $V_{in} = 20\text{mV}_{P-P}$

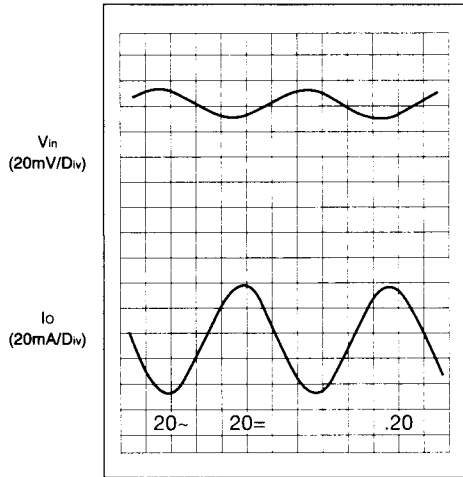

(2) $f_{in} = 1\text{KHz}$, $V_{in} = 200\text{mV}_{P-P}$

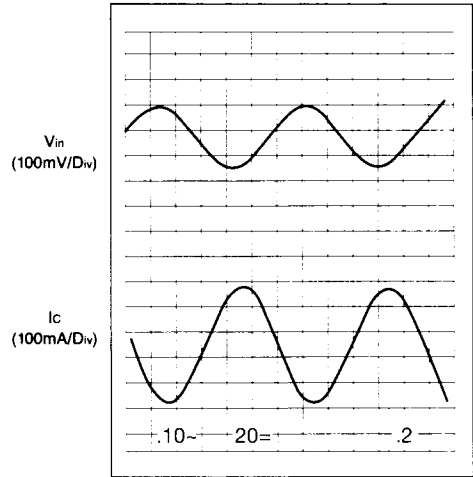

(3) $f_{in} = 400\text{Hz}$, $V_{in} = 2\text{V}_{P-P}$, $V_{ext3} = 1.5\text{V}$

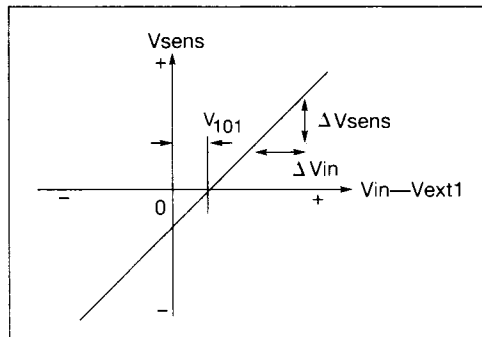
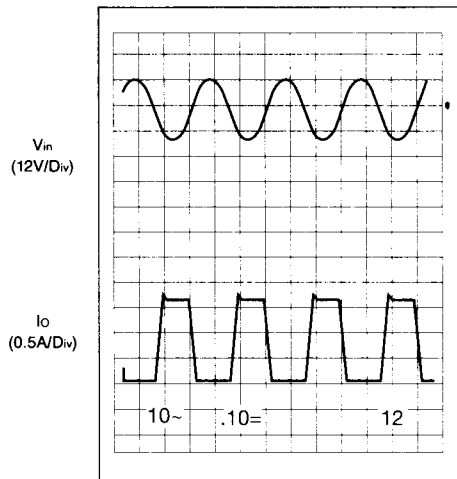

Figure 1

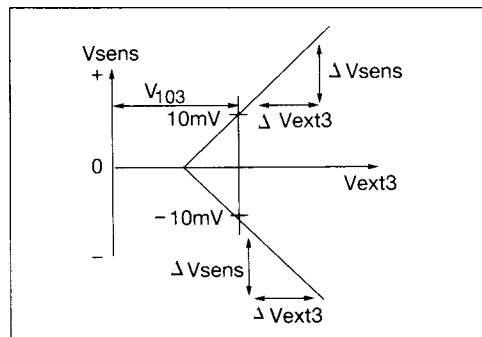
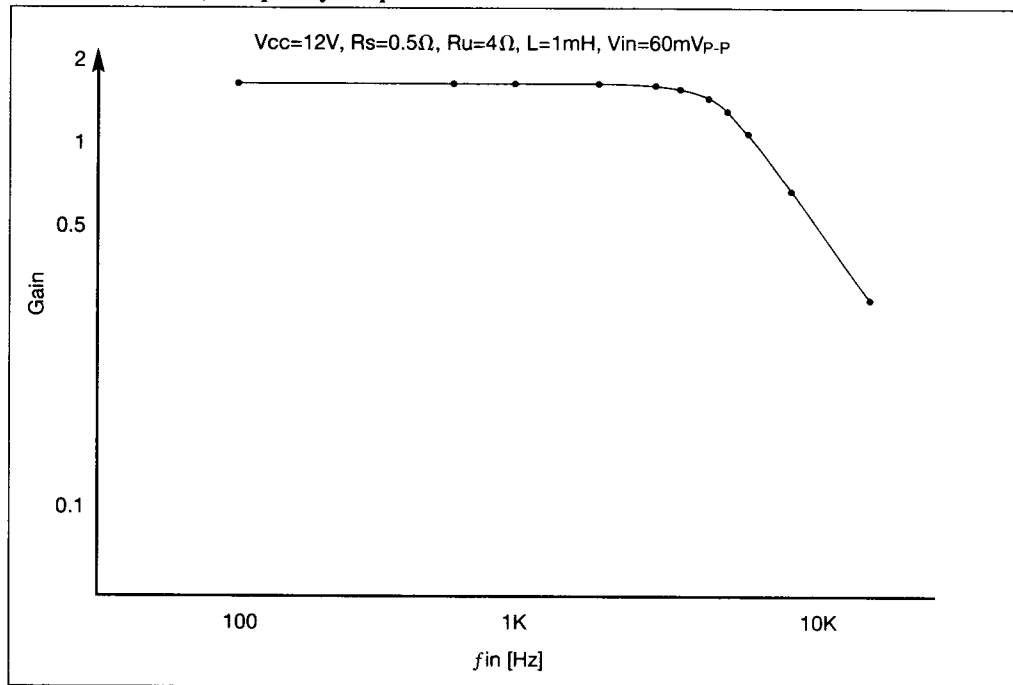

Figure 2

HA13470

HA13470 Overall, Frequency Response



HA13470 Overall, Phase Shift

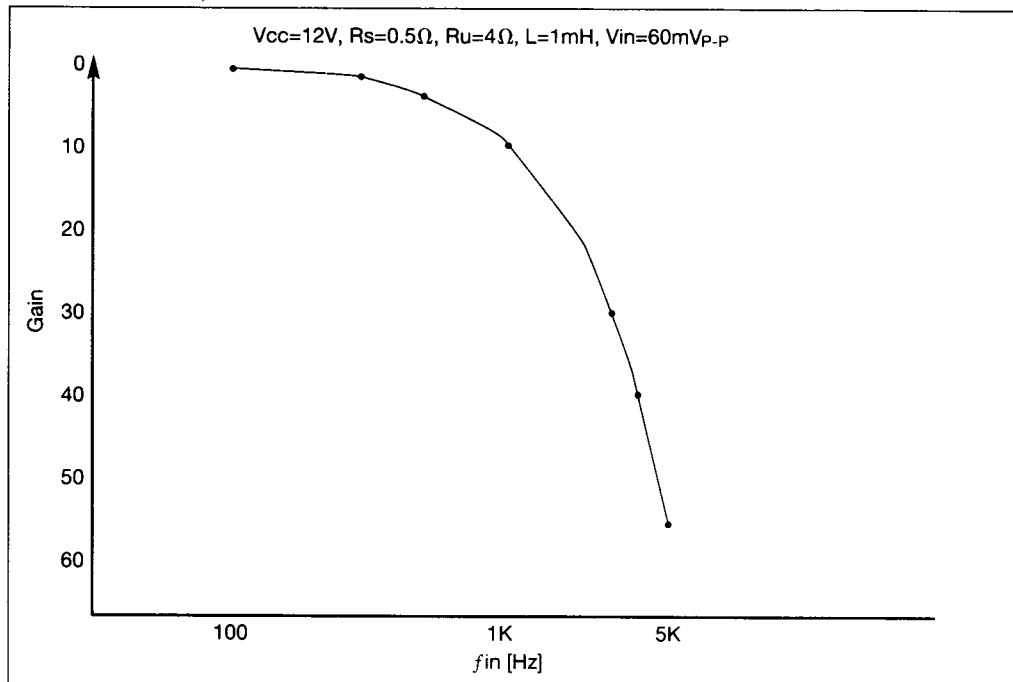

Transmitter

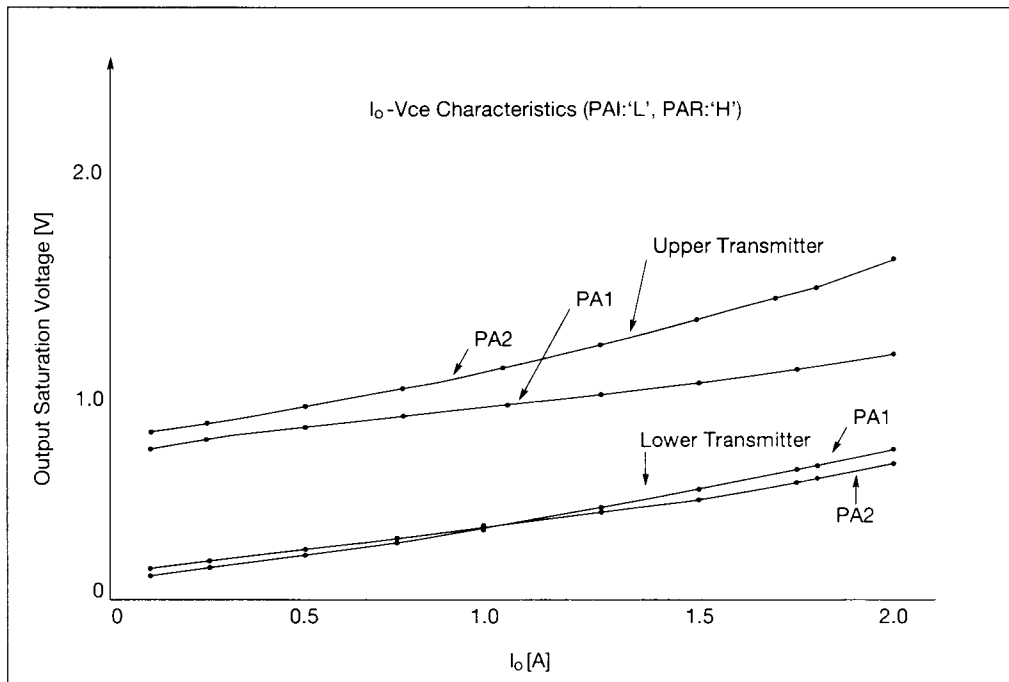

The Gain of Current Limiter V_{ext}-V_{sense}

