

Analog Clock IC with Melody

Description

The e5310Y is an integrated circuit in low-power CMOS technology for analog timers with high-quality melody and hourly chime output.

Features

- Digital synthesizer for high-quality melody sound
- Mask-programmable melody ROM
- Two sequences with 64 notes each or one sequence with 128 notes
- Hourly chime
- Quarter or half hour melody mode
- Day/ night sound attenuation
- Melody on/ off capability
- 4.192-MHz on-chip quartz oscillator
- Motor pulse output with a pulse length of 47 ms (31 ms available as option)

Block Diagram

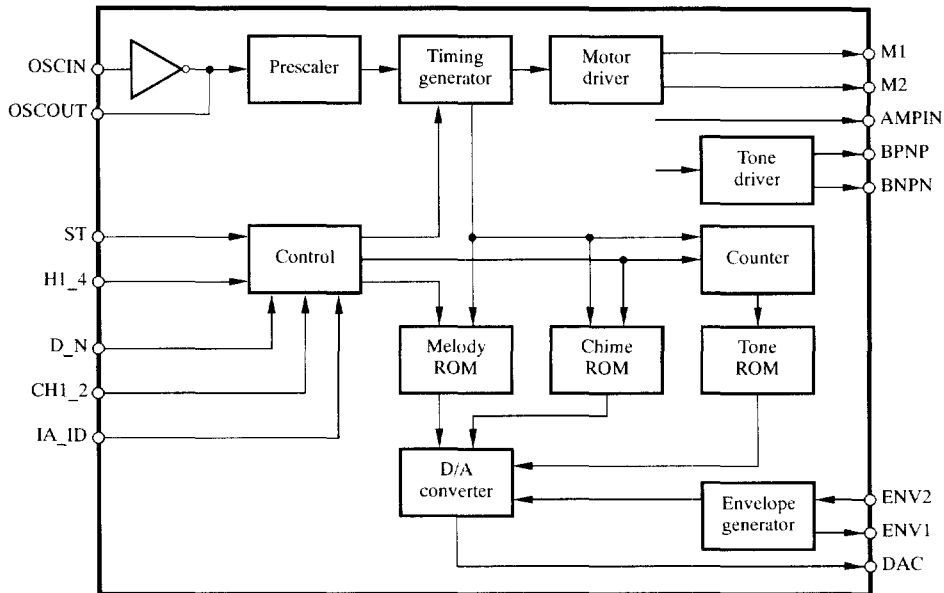

Figure 1. Block diagram

Ordering Information

Extended Type Number	Package	Remarks
e5310Yx	SO28	Tube

Pin Description

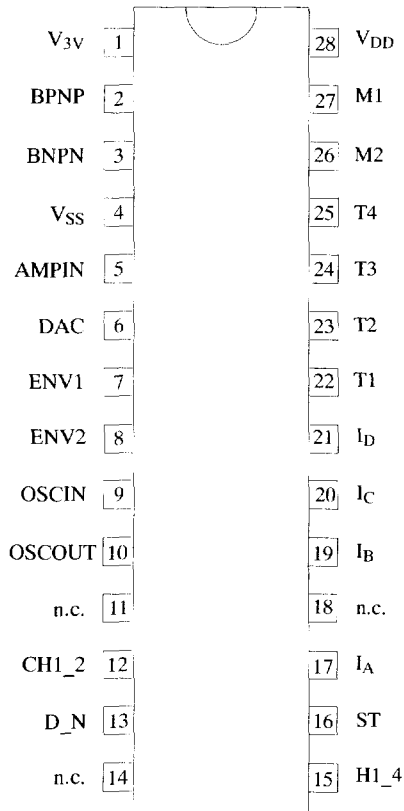

Figure 2. Pinning e5310Y

Pin	Symbol	Function
1	V _{3V}	Supply voltage 2
2	BPNP *)	Speaker output
3	BPNP	Speaker output
4	V _{SS}	Supply reference
5	AMPIN *)	Volume control
6	DAC	D/A converter output
7	ENV1	Envelope adjust
8	ENV2	Envelope adjust
9	OSCIN	Oscillator input
10	OSCOUT	Oscillator output
11	n.c.	Not connected
12	CH1_2	Function select
13	D_N	Function select
14	n.c.	Not connected
15	H1_4	Function select
16	ST	Function select
17	I _A	Hourly chime programm.
18	n.c.	Not connected
19	I _B	Hourly chime programm.
20	I _C	Hourly chime programm.
21	I _D	Hourly chime programm.
22	T1	Internal testpin
23	T2	Internal testpin
24	T3	Internal testpin
25	T4	Internal testpin
26	M2	Motor output 2
27	M1	Motor output 1
28	V _{DD}	Supply voltage 1

*) These pins are not available for type e5310YA

Absolute Maximum Ratings

Parameters	Symbol	Value	Unit
Supply voltage 1	V _{DD}	-0.3 to +2.0 V	V
Supply voltage 2	V _{3V}	-0.3 to +4.0 V	V
Input voltage range (on any pins)	V _{IN}	(V _{SS} - 0.3 V) ≤ V _{IN} ≤ (V _{DD} + 0.3 V)	V
Output voltage	V _{OUT}	(V _{SS} - 0.3 V) ≤ V _{OUT} ≤ (V _{DD} + 0.3 V)	V
Output current	I _{OUT}	30	mA
Power dissipation (DIL package)	P _{tot}	125 mW	mW
Operating ambient temperature range	T _{amb}	-10 to +60	°C
Storage temperature range	T _{stg}	-40 to +125	°C
Soldering temperature (t < 10 s)	T _{sd}	260	°C

Absolute maximum ratings define parameter limits which, if exceeded, may permanently change or damage the device. All inputs and outputs in this circuit are protected against electrostatic discharges. However,

precautions to minimize the build-up of electrostatic charges during handling are recommended. This circuit is protected against supply voltage reversal for typically 5 minutes.

Operating Characteristics

$V_{DD} = 1.5\text{ V}$, $V_{SS} = 0\text{ V}$, $T_{amb} = +25^{\circ}\text{C}$; unless otherwise specified. All voltage levels are measured with reference to V_{SS} . The current flowing into the device is positive.

Parameters	Test Conditions / Pins	Symbol	Min.	Typ.	Max.	Unit
Supply voltage 1		V_{DD}	1.2	1.5	1.8	V
Supply voltage 2		V_{3V}	2.4	3.0	3.6	V
Operating current	Note 1	I_{DD}		60	110	μA
Motor outputs M1 and M2						
Output current	$R_L = 200\ \Omega$, $V_{DD} = 1.2\text{ V}$	I_M	3.5	4		mA
Motor period		t_M		1		s
Pulse width *) Mask option		t_{pw}	31.2 *)	46.8		ms
Hour code input pins I_A, I_B, I_C and I_D						
Input current high	$V_{IN} = V_{DD}$	I_{IH}		4	15	μA
Control input pins D_N and CHI₂						
Input current high	$V_{IN} = V_{DD}$	I_{IH}		1	4	μA
Input current low	$V_{IN} = V_{SS}$	I_{IL}		-1	-4	μA
Quartz oscillator						
Frequency		f_C		4.194		MHz
Start-up time	$V_{DD} = 1.2\text{ V}$	t_{Start}		2	3	s
Frequency stability	$\Delta V_{DD} = 100\text{ mV}$	$\Delta f/f$		0.2	0.6	ppm
e5310YA Note 2						
Output current	$BNPN = V_{SS}$	I_{BNPN}	0.2		0.5	mA
e5310YB Note 2						
Output current	$BNPN = V_{SS}$, $AMPIN = V_{SS}$	I_{BNPN}	0.25			mA
	$BNPN = V_{DD}$, $AMPIN = V_{DD}$	I_{BNPN}	-0.3			mA
	$DAC = V_{DD}$	I_{DAC}	13		28	μA
e5310YC with $V_{3V} = 3\text{ V}$ Note 2						
Output current	$BNPN = V_{SS}$, $AMPIN = V_{SS}$	I_{BNPN}	2.0			mA
	$BNPN = 3\text{ V}$, $AMPIN = 3\text{ V}$	I_{BNPN}	2.5			mA
	$DAC = V_{DD}$	I_{DAC}	13		28	μA

Note 1: This current is measured when the crystal oscillator is active, not in melody mode and no motor load

Note 2: Output current measured with $R_{ENV2} = 560\text{ k}\Omega$ and all tone ROM output bits = 1

Table 1 Truth Table for Hourly Chime

I_D	I_C	I_B	I_A	Hour	Chimes
0	0	0	1	1:00	1
0	0	1	0	2:00	2
0	0	1	1	3:00	3
0	1	0	0	4:00	4
0	1	0	1	5:00	5
0	1	1	0	6:00	6
0	1	1	1	7:00	7
1	0	0	0	8:00	8
1	0	0	1	9:00	9
1	0	1	0	10:00	10
1	0	1	1	11:00	11
1	1	0	0	12:00	12

Application Circuit Diagrams Using the e5310Y

Function select according to switch position:

CH1_2	=	VSS	Melody off
CH1_2	=	VDD	Melody 1 (Westminster)
CH1_2	=	open	Melody 2 (Bim-bam)
D_N	=	VSS	No sound during night time
D_N	=	VDD	Half volume level at night
D_N	=	open	Same volume level for day and night
H1_4	=	VDD	Chime on full hour only
H1_4	=	VSS or open	1/4, 2/4, 3/4 and 4/4 h chime
ST	=	VSS>VDD	Positive edge trigger for hourly chime

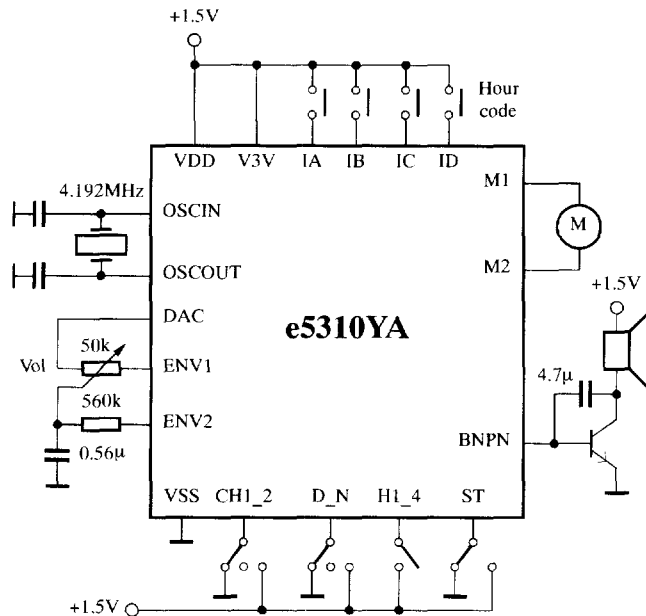

Figure 3. Class A output buffer at supply voltage of 1.5 V

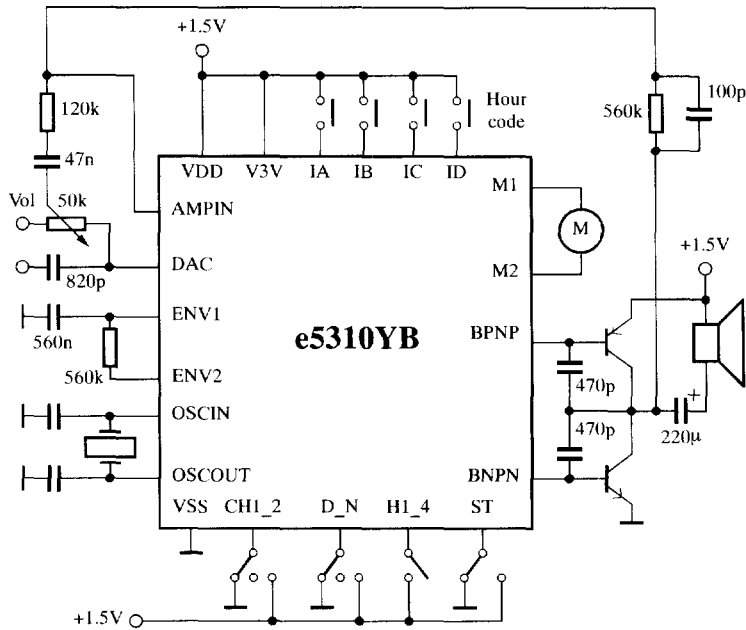

Figure 4. Class B output buffer at supply voltage of 1.5 V

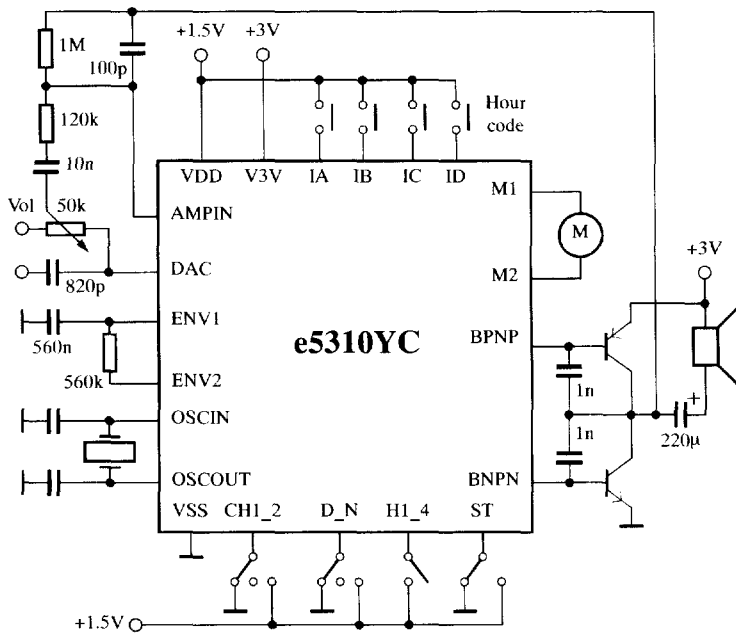
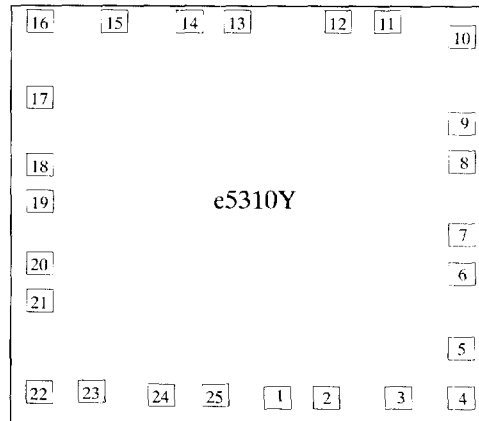

Figure 5. Class B output buffer at supply voltage of 3 V



Pad size = 90 μm \times 90 μm
 Chip size = 2.33 mm \times 2.22 mm = 5.17 mm²

Figure 6. Pad layout of the e5310 chip

Table 2 Pad coordinates

Pad Number	Pin Name	X Position	Y Position
1	V _{3V}	97	-986
2	BNPN	266	-986
3	BNPN	788	-986
4	V _{SS}	952	-986
5	AMPIN	954	-803
6	DAC	954	-426
7	ENV1	954	-258
8	ENV2	954	119
9	OSCIN	954	287
10	OSCOUT	954	845
11	CH1_2	602	985
12	D_N	434	985
13	HL_4	-12	985
14	ST	-180	985
15	I _A	-557	985
16	I _B	-956	985
17	I _C	-954	479
18	I _D	-954	102
19	T1	-954	-66
20	T2	-954	-443
21	T3	-954	-611
22	T4	-954	-986
23	M2	-763	-986
24	M1	-241	-986
25	V _{DD}	-73	-986

Package Information

Package SO28

Dimensions in mm

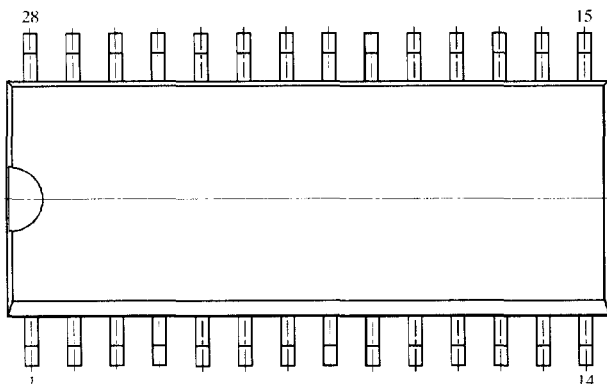
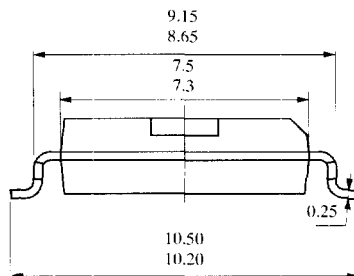
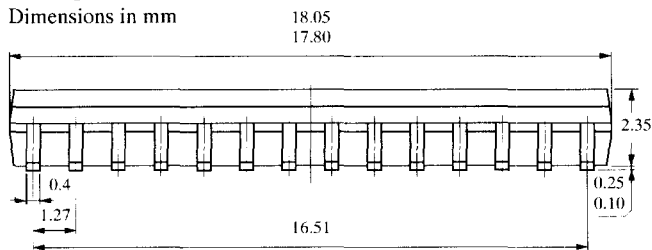

technical drawings
according to DIN
specifications