

Block Diagram

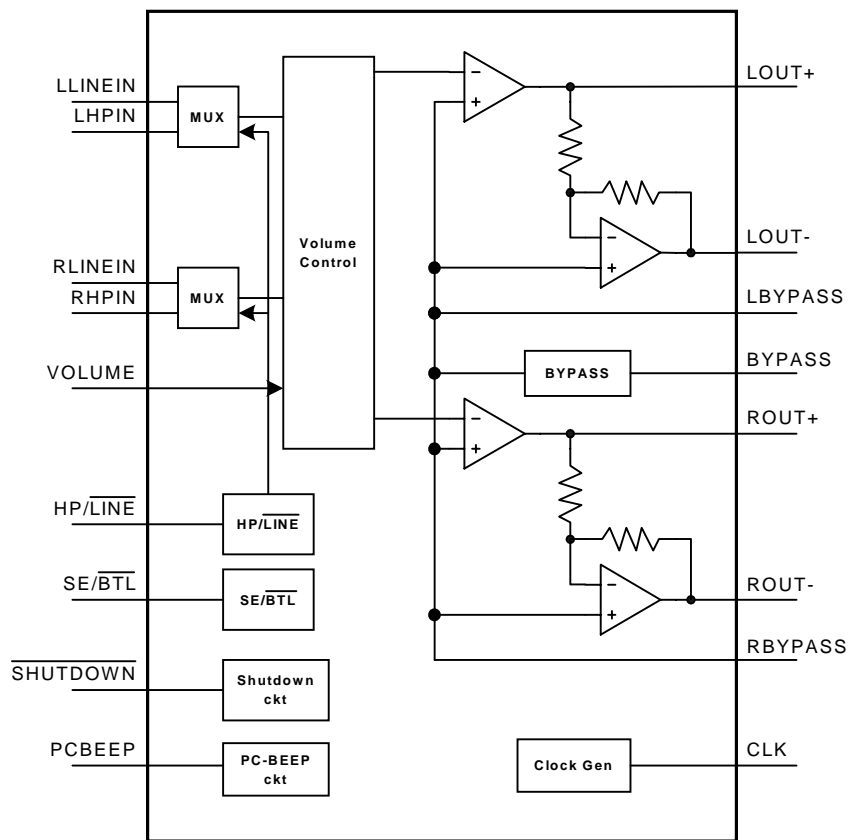

For APA2121

Absolute Maximum Ratings

(Over operating free-air temperature range unless otherwise noted.)

Symbol	Parameter	Rating	Unit
V_{DD}	Supply Voltage Range	-0.3 to 6	V
V_{IN}	Input Voltage Range, SE/BTL, HP/LINE, SHUTDOWN, PCBEN	-0.3 to $V_{DD}+0.3$	V
T_A	Operating Ambient Temperature Range	-40 to 85	°C
T_J	Maximum Junction Temperature	Internal Limited*1	°C
T_{STG}	Storage Temperature Range	-65 to +150	°C
T_S	Soldering Temperature, 10 seconds	260	°C
V_{ESD}	Electrostatic Discharge	-3000 to 3000*2 -200 to 200*3	V
P_D	Power Dissipation	Internal Limited	

Note:

- 1.APA2120/1 integrated internal thermal shutdown protection when junction temperature ramp up to 150°C
- 2.Human body model: C=100pF, R=1500Ω, 3 positives pulse plus 3 negative pulses
- 3.Machine model: C=200pF, L=0.5μF, 3 positive pulses plus 3 negative pulses

Recommended Operating Conditions

		Min.	Max.	Unit
Supply Voltage, V_{DD}		4.5	5.5	V
High level threshold voltage, V_{IH}	SHUTDOWN, PCBEN	2		V
	SE/BTL, HP/LINE	4		
Low level threshold voltage, V_{IL}	SHUTDOWN, PCBEN		1.0	V
	SE/BTL, HP/LINE		3	
Common mode input voltage, V_{ICM}		$V_{DD}-1.0$		V

Thermal Characteristics

Symbol	Parameter	Value	Unit
R_{THJA}	Thermal Resistance from Junction to Ambient in Free Air TSSOP-P*	45	K/W

* 5 in² printed circuit board with 2oz trace and copper pad through 9 25mil diameter vias.
The thermal pad on the TSSOP_P package with solder on the printed circuit board.

Electrical Characteristics

$V_{DD}=5V$, $-20^{\circ}C < T_A < 85^{\circ}C$ (unless otherwise noted)

Symbol	Parameter	Test Condition	APA2120/1			Unit
			Min.	Typ.	Max.	
V_{DD}	Supply Voltage		4.5		5.5	V
I_{DD}	Supply Current	SE/BTL=0V		14	25	mA
		SE/BTL=5V		8.0	15	
I_{SD}	Supply Current in Shutdown Mode	SE/BTL=5V SHUTDOWN=0V		50		μA
I_{IH}	High input Current			900		nA
I_{IL}	Low Input Current			900		nA
V_{OS}	Output Differential Voltage			5		mV

Electrical Characteristics (Cont.)

Operating Characteristics, BTL mode

$V_{DD}=5V, T_A=25^{\circ}C, R_L=4\Omega, \text{Gain}=2V/V$ (unless otherwise noted)

Symbol	Parameter	Test Condition	APA2120/1			Unit
			Min.	Typ.	Max.	
P _o	Maximum Output Power	THD=10%, R _L =3Ω, Fin=1kHz		2.7		W
		THD=10%, R _L =4Ω, Fin=1kHz		2.3		
		THD=10%, R _L =8Ω, Fin=1kHz		1.5		
		THD=1%, R _L =3Ω, Fin=1kHz		2.0		
		THD=1%, R _L =4Ω, Fin=1kHz		1.9		
		THD=0.5%, R _L =8Ω, Fin=1kHz	1	1.1		
THD+N	Total Harmonic Distortion Plus Noise	P _o =1.5W, R _L =4Ω, Fin=1kHz		0.05		%
		P _o =1W, R _L =8Ω, Fin=1kHz		0.07		
PSRR	Power Ripple Rejection Ratio	V _{IN} =0.1Vrms, R _L =8Ω, C _B =1μF, Fin=120Hz		60		dB
Xtalk	Channel Separation	C _B =1μF, R _L =8Ω, Fin=1kHz		90		dB
S/N	Signal to Noise Ratio	P _o =1.1W, R _L =8Ω, A_wieght		95		dB

Operating Characteristics, SE mode

$V_{DD}=5V, T_A=25^{\circ}C, R_L=4\Omega, \text{Gain}=1V/V$ (unless otherwise noted)

Symbol	Parameter	Test Condition	APA2120/1			Unit
			Min.	Typ.	Max.	
P _o	Maximum Output Power	THD=10%, R _L =8Ω, Fin=1kHz		400		mW
		THD=10%, R _L =32Ω, Fin=1kHz		110		
		THD=1%, R _L =8Ω, Fin=1kHz		320		
		THD=1%, R _L =32Ω, Fin=1kHz		90		
THD+N	Total Harmonic Distortion Plus Noise	P _o =250mW, R _L =8Ω, Fin=1kHz		0.08		%
		P _o =75mW, R _L =32Ω, Fin=1kHz		0.08		
PSRR	Power Ripple Rejection Ratio	V _{IN} =0.1Vrms, R _L =8Ω, C _B =1μF, Fin=120Hz		48		dB
Xtalk	Channel Separation	C _B =1μF, R _L =32Ω, Fin=1kHz		100		dB
S/N	Signal to Noise Ratio	P _o =75mW, SE, R _L =32Ω, A_wieght		100		dB

Pin Description

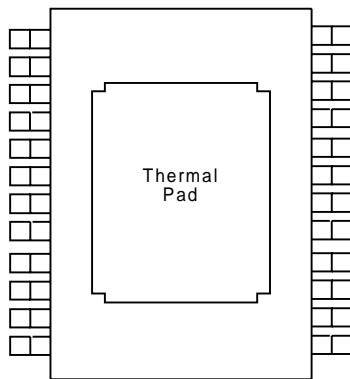
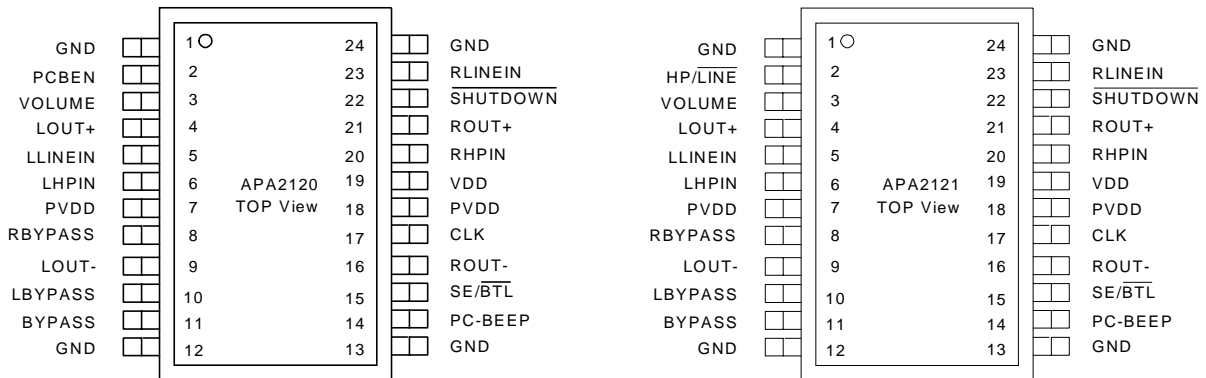

APA2120/1
Bottom View

	Multiple Input Selection	PCBEEP Control Input
APA2120	SE/BTL	PCBEN
APA2121	HP/LINE	-

Pin Function Description

Pin		Config.	Description
Name	No		
GND	1,12, 13,24		Ground connection, Connected to thermal pad.
PCBEN	2	I/P	BEEP mode control input, active H, for APA2120 only
HP/LINE	2	I/P	Multi-input selection input, headphone mode when held high, line-in mode when held low for APA2121 only.
VOLUME	3		Input signal for internal volume gain setting.
LOUT+	4	O/P	Left channel positive output in BTL mode and SE mode.
LLINEIN	5	I/P	Left channel line input terminal, selected when HP/LINE is held low.
LHPIN	6	O/P	Left channel headphone input terminal, selected when HP/LINE is held high.
PVDD	7,18		Supply voltage only for power amplifier.
RBYPASS	8	I/P	Right channel bypass voltage.
LOUT-	9	O/P	Left channel negative output in BTL mode and high impedance in SE mode.
LBYPASS	10	I/P	Left channel bias voltage generator.
BYPASS	11		Bias voltage generator
PC_BEEP	14	I/P	PCBEP signal input
SE/BTL	15	I/P	Output mode control input, high for SE output mode and low for BTL mode.
ROUT-	16	O/P	Right channel negative output in BTL mode and high impedance in SE mode.
CLK	17		Clock signal generator
VDD	19		Supply voltage for internal circuit excepting power amplifier.
RHPIN	20	I/P	Right channel headphone input terminal, selected when HP/LINE is held high.
ROUT+	21	O/P	Right channel positive output in BTL mode and SE mode.
SHUTDOWN	22	I/P	It will be into shutdown mode when pull low.
RLINEIN	23	I/P	Right channel line input terminal, selected when HP/LINE is held low.

Control Input Table

For APA2120

SE/BTL	SHUTDOWN	PC-BEEP	Operating mode
X	L	Disable	Shutdown mode
L	H	Disable	Line input, BTL out
H	H	Disable	HP input, SE out
X	X	Enable	PCBEEP input, BTL out

For APA2121

SE/BTL	HP/LINE	SHUTDOWN	PC-BEEP	Operating mode
X	X	L	Disable	Shutdown mode
L	L	H	Disable	Line input, BTL out
L	H	H	Disable	HP input, BTL out
H	L	H	Disable	Line input, SE out
H	H	H	Disable	HP input, BTL out
X	X	X	Enable	PCBEEP input, BTL out

Typical Application Circuit

APA2120

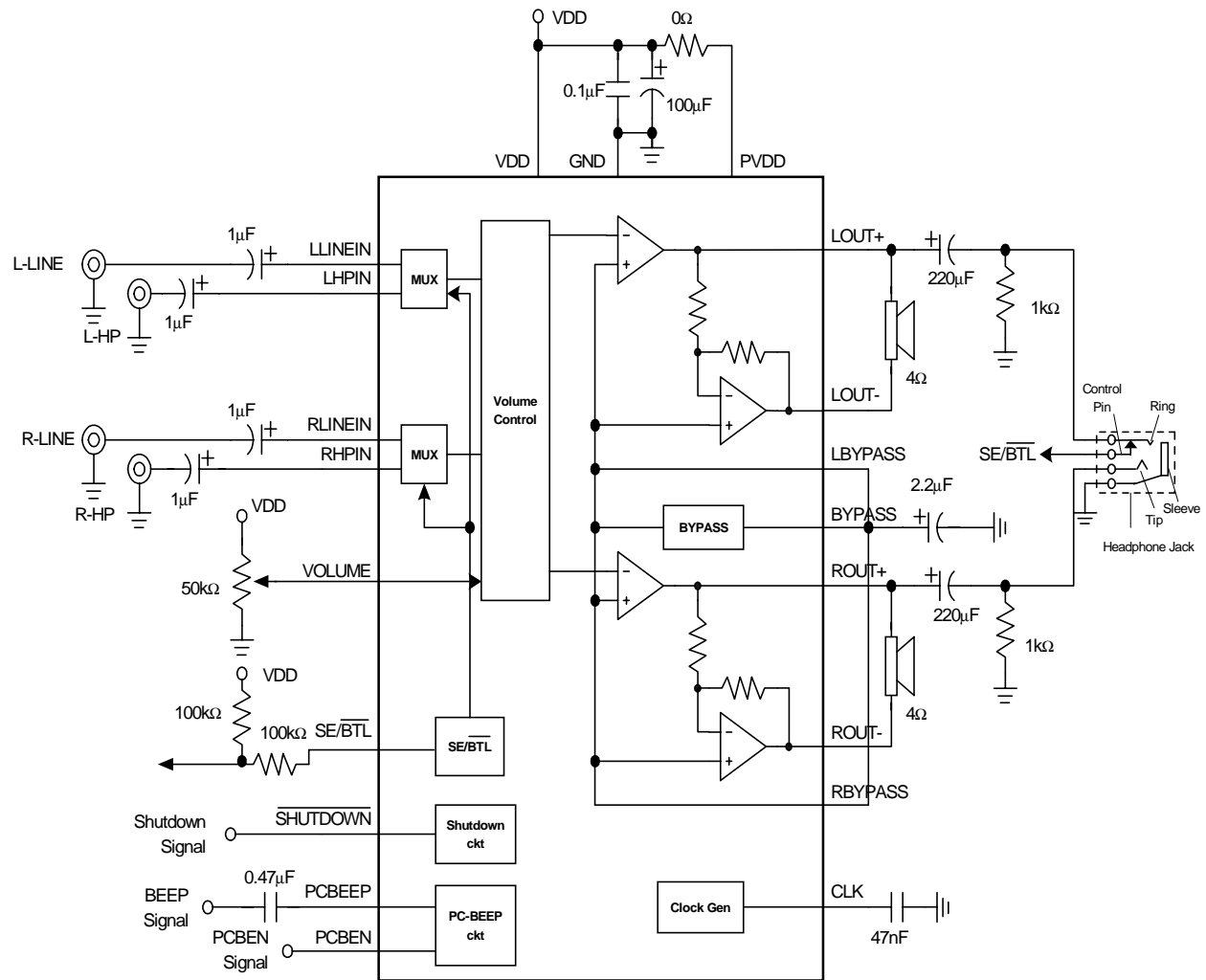

Typical Application Circuit

APA2121

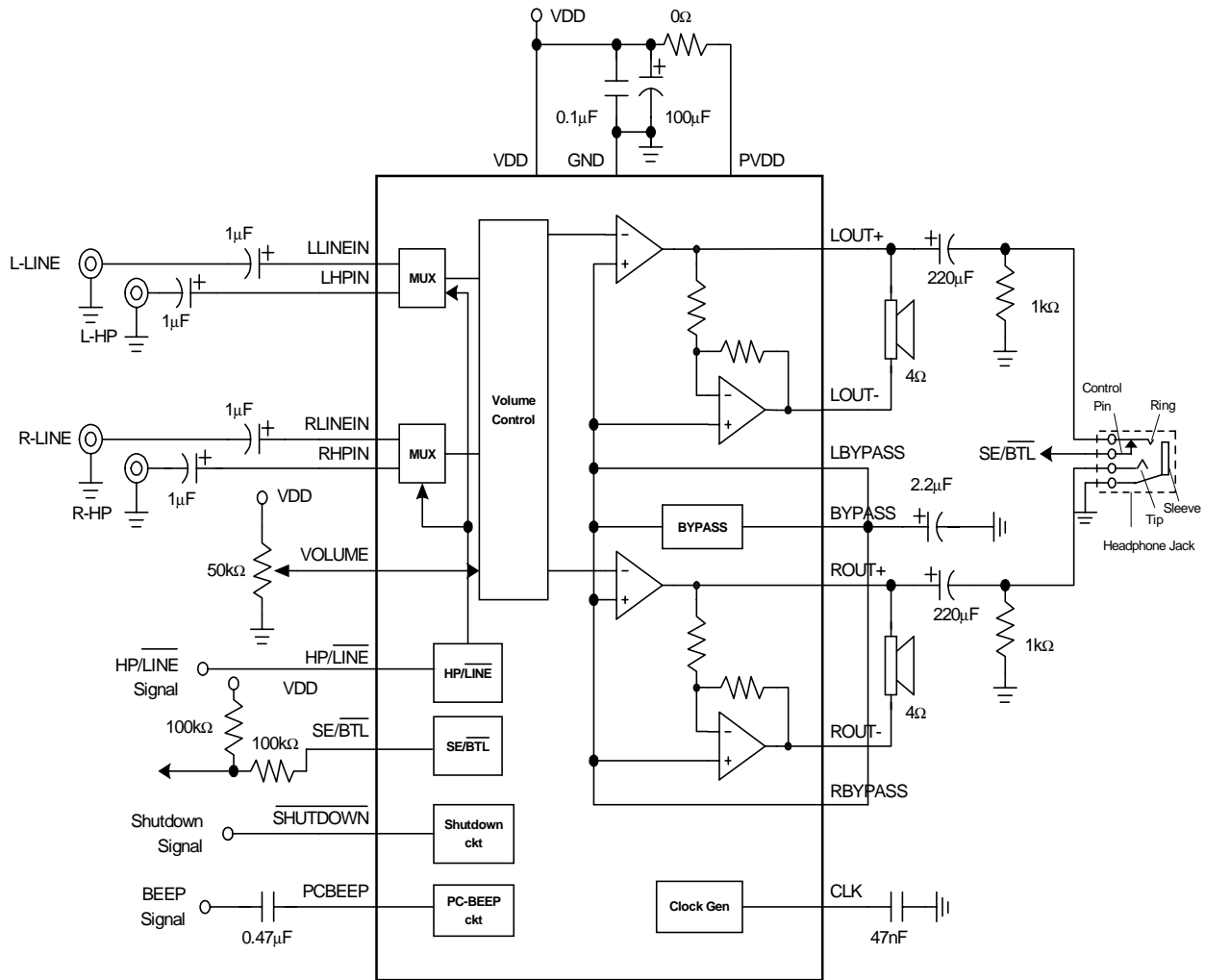

Volume Control Table_BTL Mode

Supply Voltage Vdd=5V

Gain(dB)	High(V)	Low(V)	Hysteresis(mV)	Recommended Voltage(V)
20	0.12	0.00		0
18	0.23	0.17	52	0.20
16	0.34	0.28	51	0.31
14	0.46	0.39	50	0.43
12	0.57	0.51	49	0.54
10	0.69	0.62	47	0.65
8	0.80	0.73	46	0.77
6	0.91	0.84	45	0.88
4	1.03	0.96	44	0.99
2	1.14	1.07	43	1.10
0	1.25	1.18	41	1.22
-2	1.37	1.29	40	1.33
-4	1.48	1.41	39	1.44
-6	1.59	1.52	38	1.56
-8	1.71	1.63	37	1.67
-10	1.82	1.74	35	1.78
-12	1.93	1.85	34	1.89
-14	2.05	1.97	33	2.01
-16	2.16	2.08	32	2.12
-18	2.28	2.19	30	2.23
-20	2.39	2.30	29	2.35
-22	2.50	2.42	28	2.46
-24	2.62	2.53	27	2.57
-26	2.73	2.64	26	2.69
-28	2.84	2.75	24	2.80
-30	2.96	2.87	23	2.91
-32	3.07	2.98	22	3.02
-34	3.18	3.09	21	3.14
-36	3.30	3.20	20	3.25
-38	3.41	3.32	18	3.36
-40	3.52	3.43	17	3.48
-80	5.00	3.54	16	5

Typical Characteristics

THD+N vs. Frequency

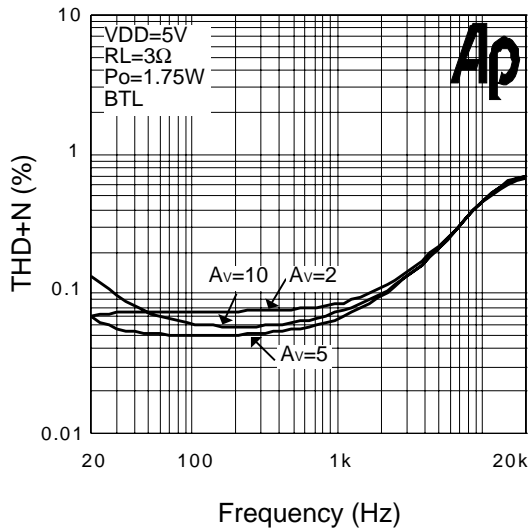

THD+N vs. Output Power

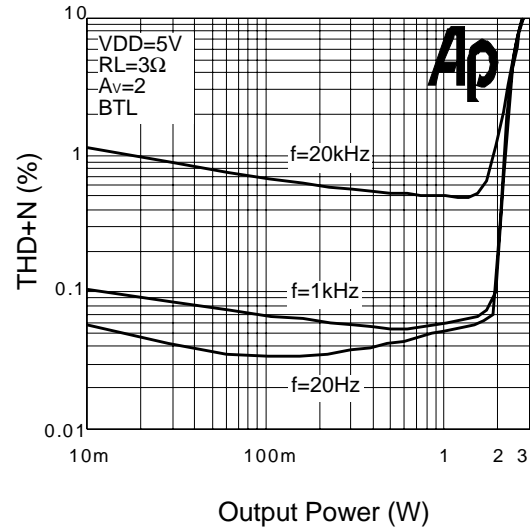

THD+N vs. Frequency

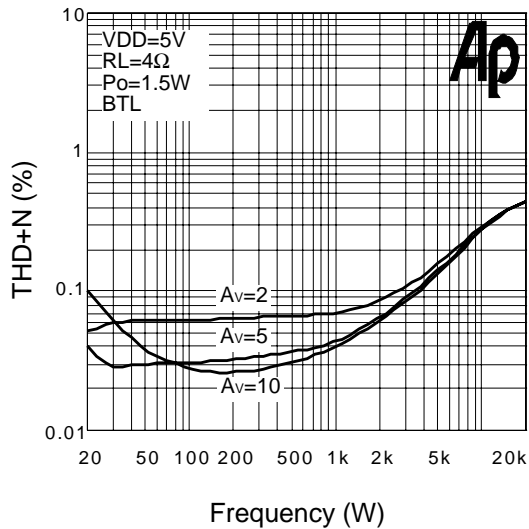

THD+N vs. Output Power

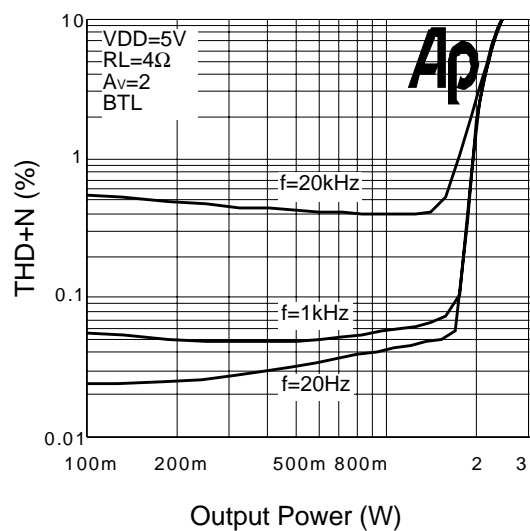

Typical Characteristics (Cont.)

THD+N vs. Frequency

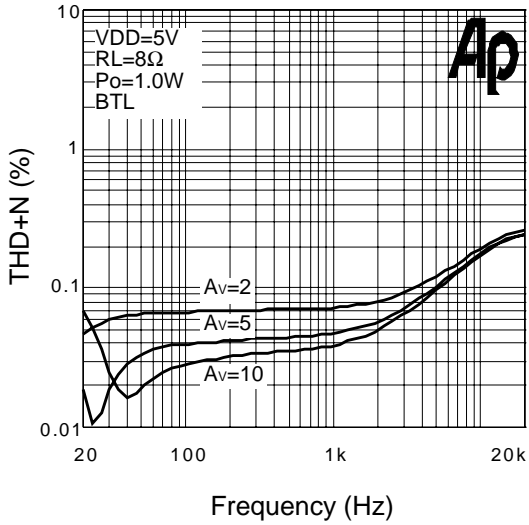

THD+N vs. Output Power

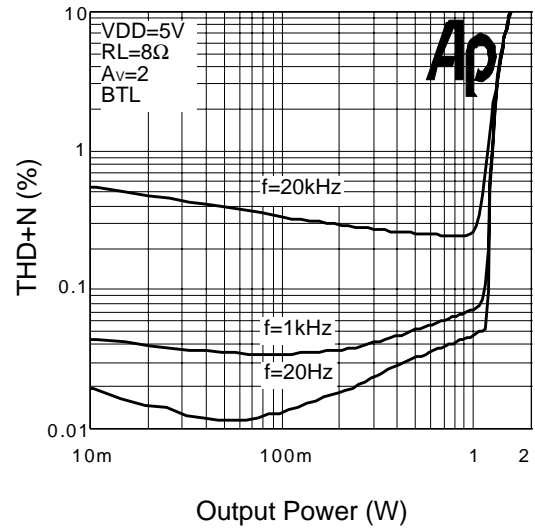

THD+N vs. Frequency

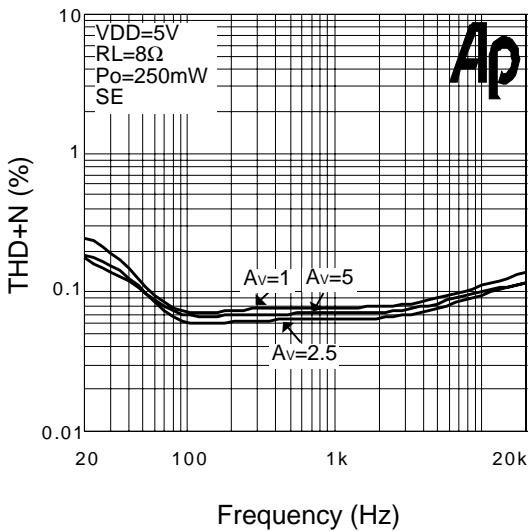

THD+N vs. Output Power

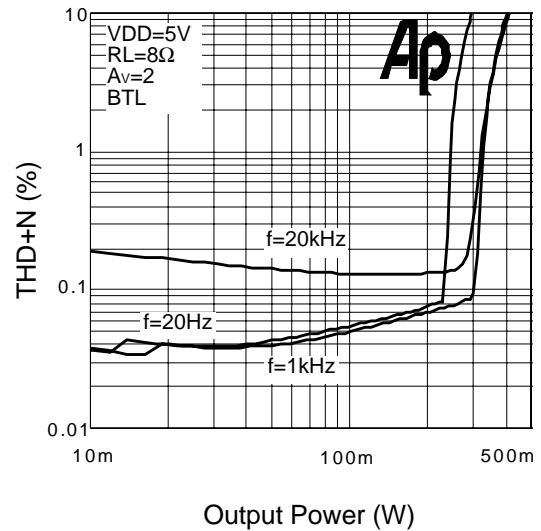

Typical Characteristics (Cont.)

THD+N vs. Frequency

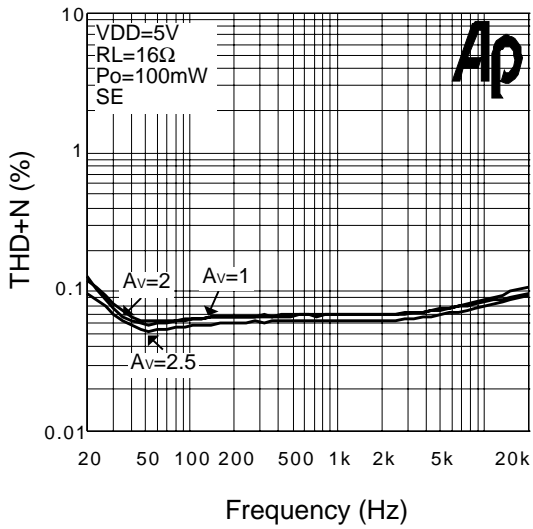

THD+N vs. Output Power

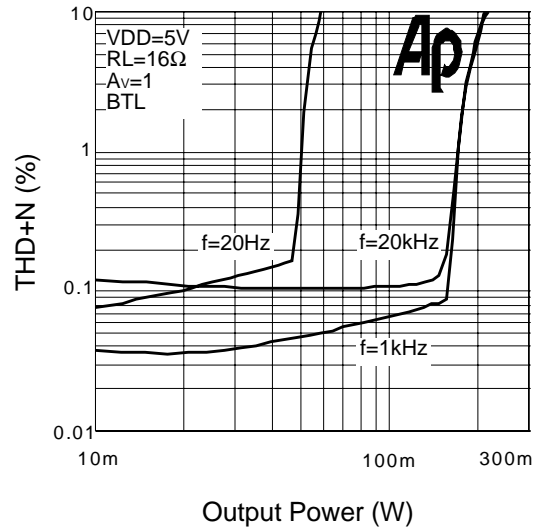

THD+N vs. Frequency

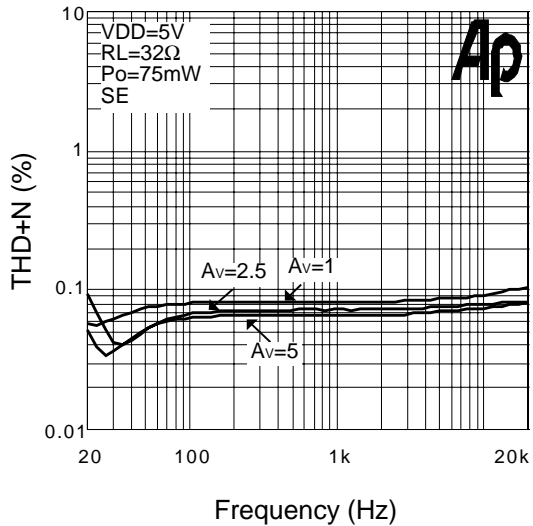

THD+N vs. Output Power

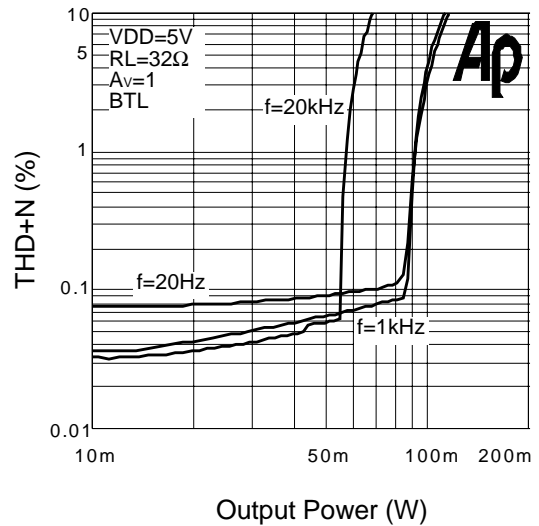

Typical Characteristics (Cont.)

THD+N vs. Frequency

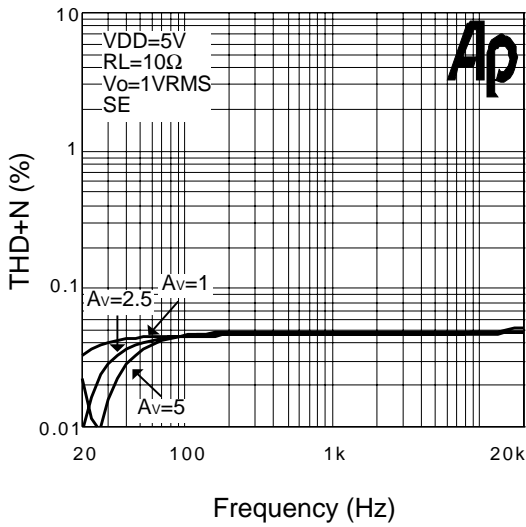

THD+N vs. Output Swing

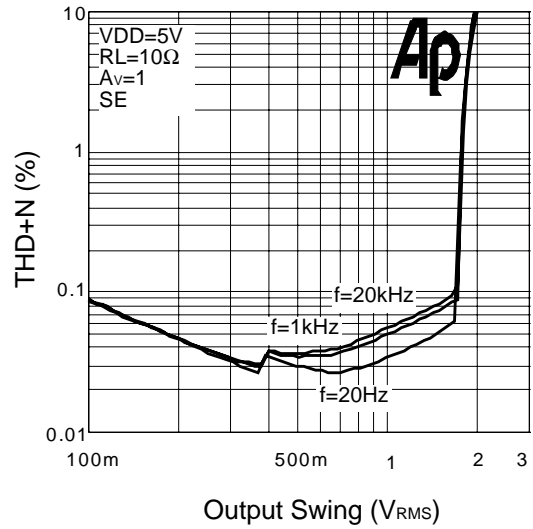

Crosstalk vs. Frequency

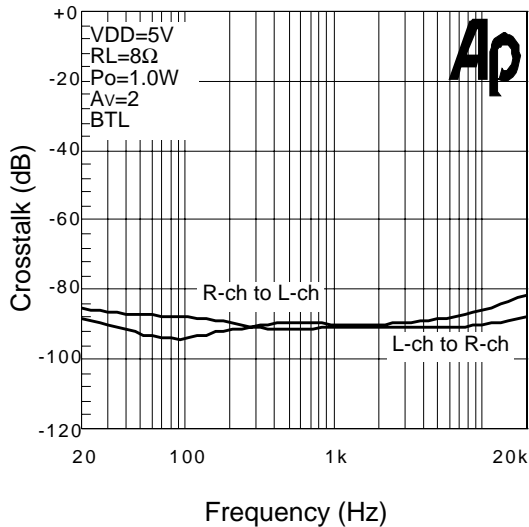

Crosstalk vs. Frequency

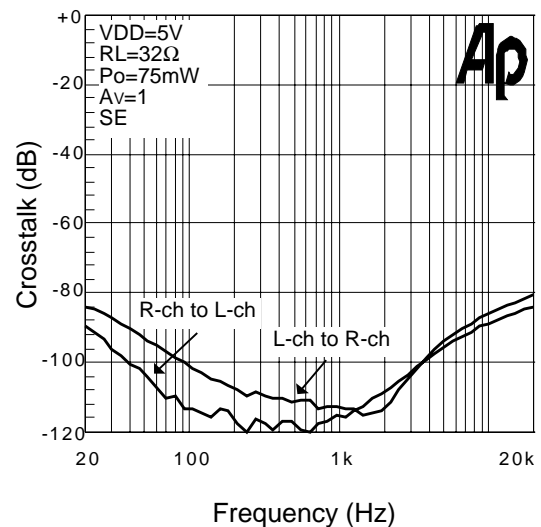

Typical Characteristics (Cont.)

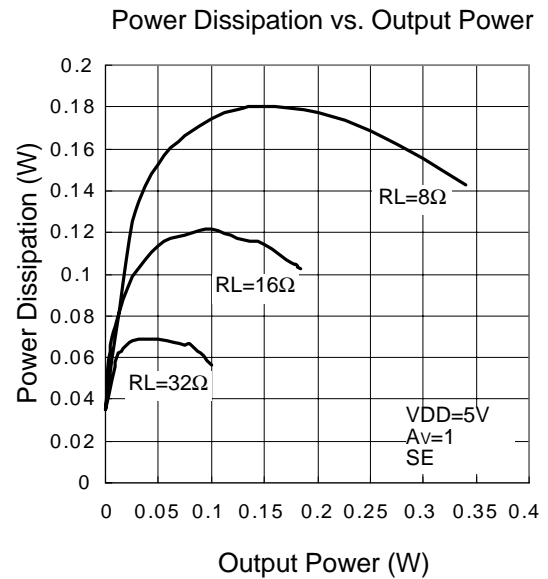
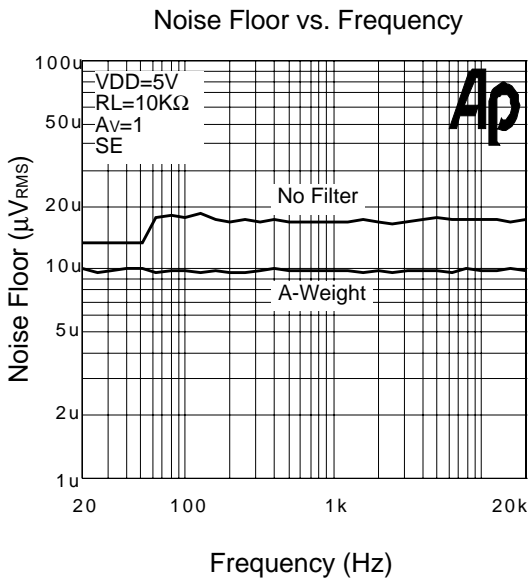
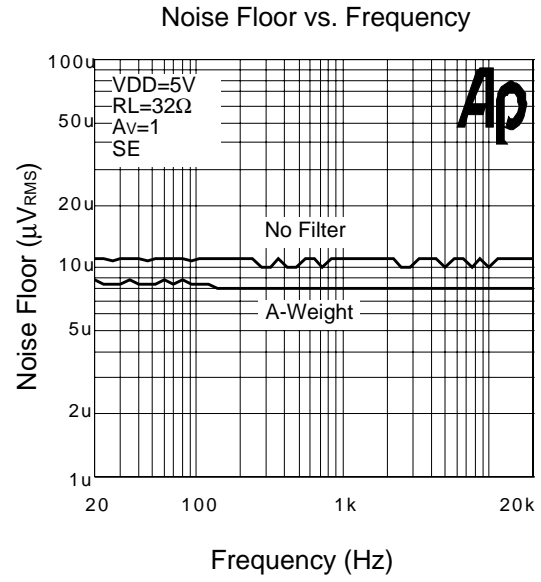
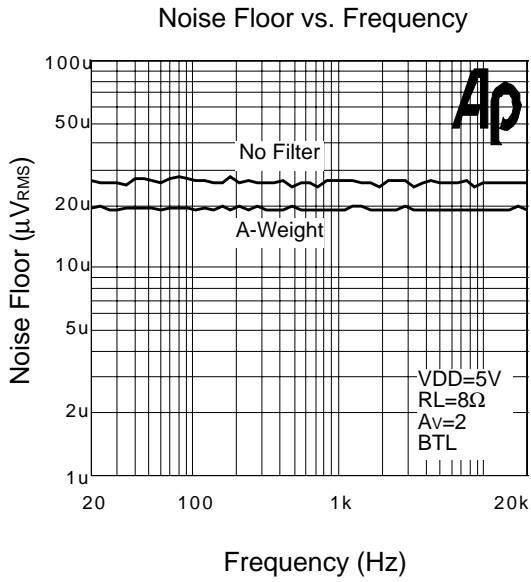

Typical Characteristics (Cont.)

Power Dissipation vs. Output Power

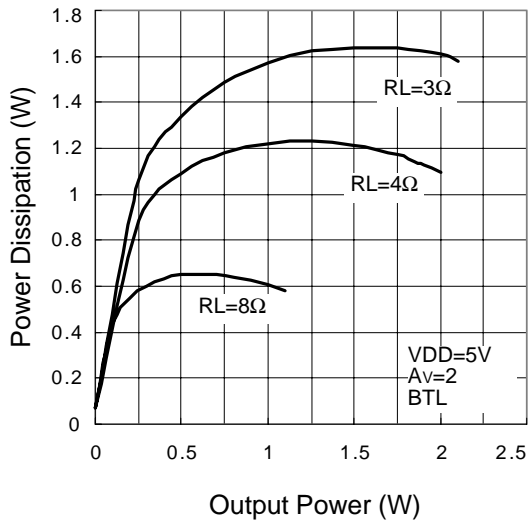

Supply Current vs. Supply Voltage

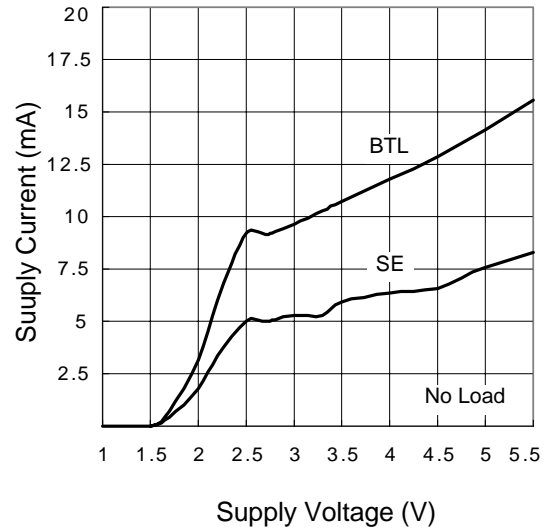

Output Power vs. Supply Voltage

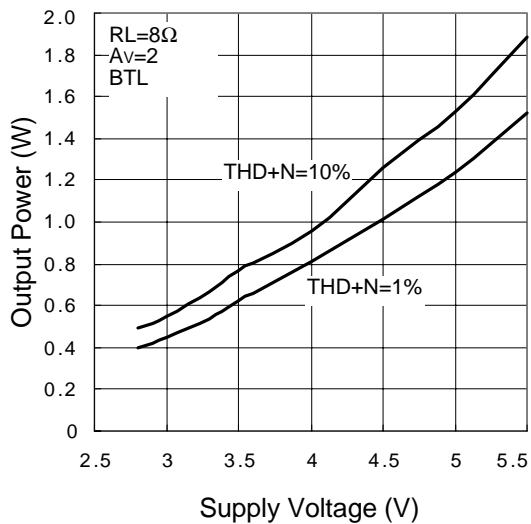

Output Power vs. Supply Voltage

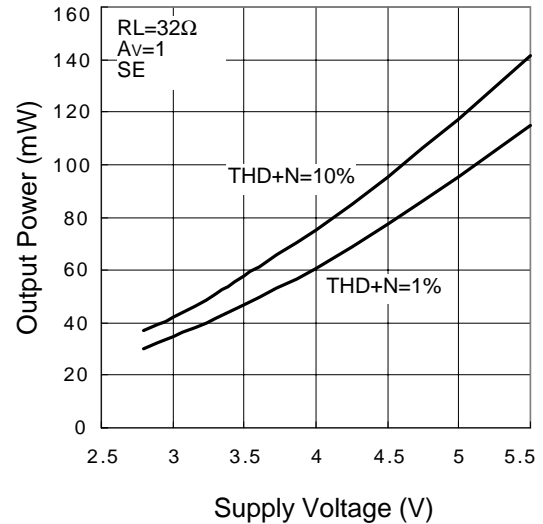

Typical Characteristics (Cont.)

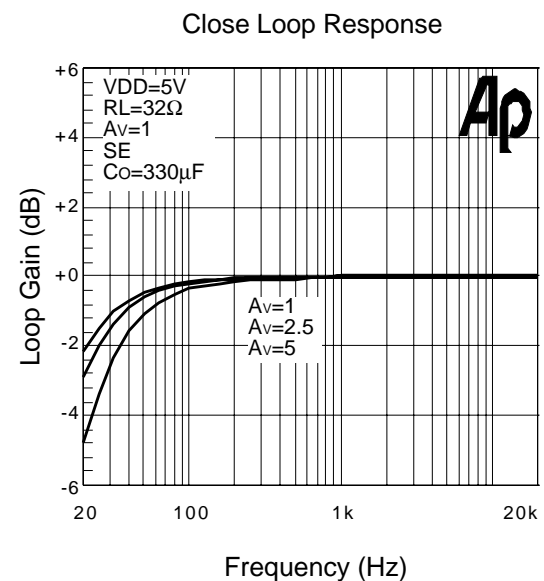
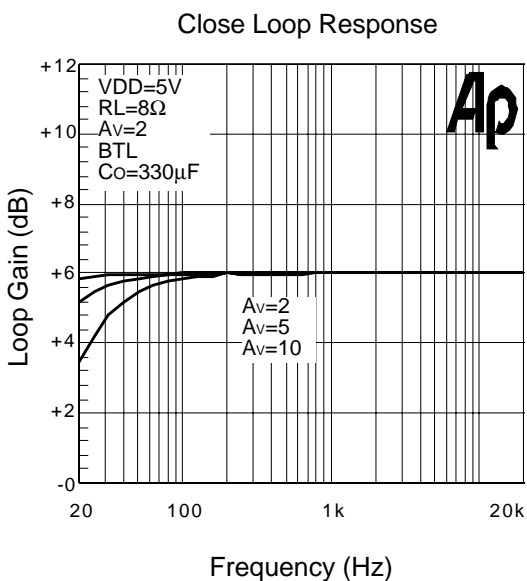
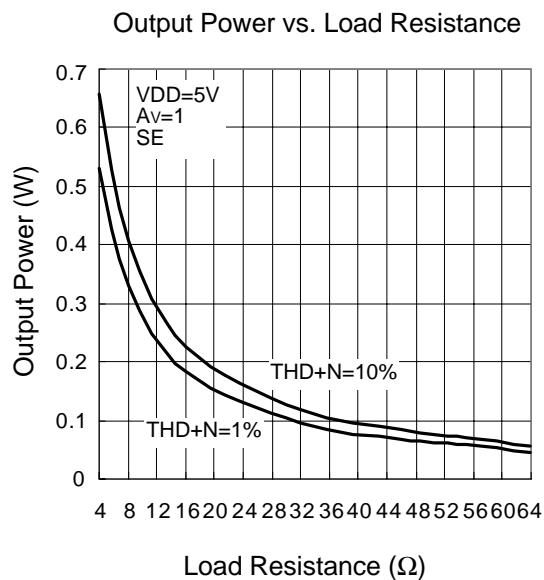
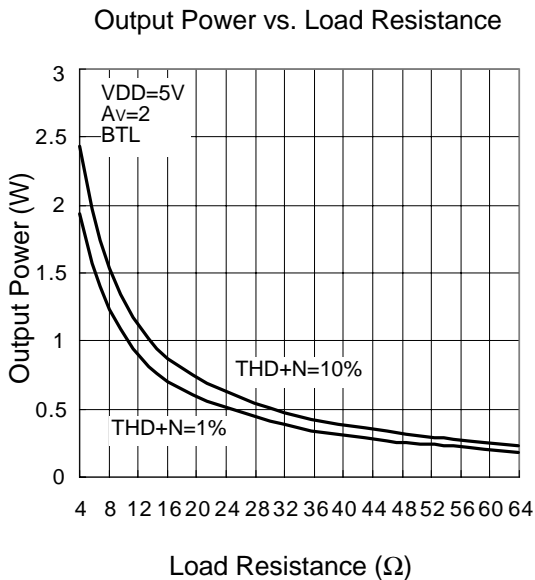

Typical Characteristics (Cont.)

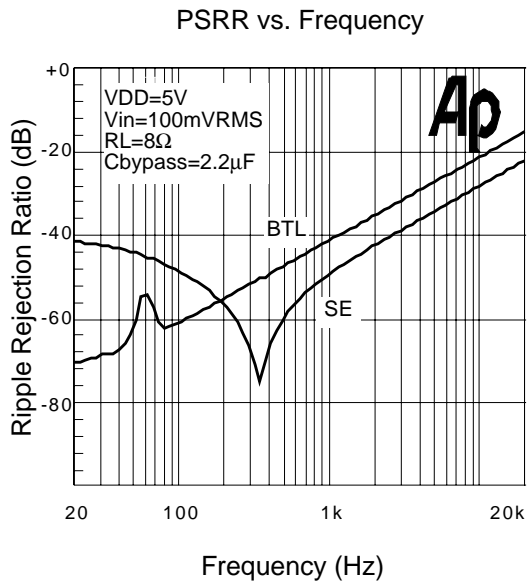

Application Descriptions

BTL Operation

The APA2120/1 output stage (power amplifier) has two pairs of operational amplifiers internally, allowed for different amplifier configurations.

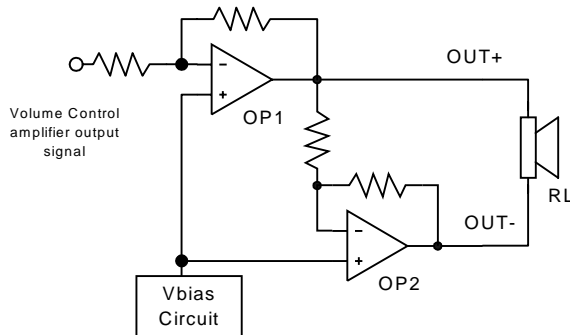

Figure 1: APA2120/1 internal configuration
(each channel)

The power amplifier's OP1 gain is setting by internal unity-gain and input audio signal is come from internal volume control amplifier, while the second amplifier OP2 is internally fixed in a unity-gain, inverting configuration. Figure 1 shows that the output of OP1 is connected to the input to OP2, which results in the output signals of with both amplifiers with identical in magnitude, but out of phase 180°. Consequently, the differential gain for each channel is 2 x (Gain of SE mode).

By driving the load differentially through outputs OUT+ and OUT-, an amplifier configuration commonly referred to as bridged mode is established. BTL mode operation is different from the classical single-ended SE amplifier configuration where one side of its load is connected to ground.

A BTL amplifier design has a few distinct advantages over the SE configuration, as it provides differential drive to the load, thus doubling the output swing for a specified supply voltage.

BTL Operation (Cont.)

Four times the output power same conditions. A BTL configuration, such as the one used in APA2120/1, also creates a second advantage over SE amplifiers. Since the differential outputs, ROUT+, ROUT-, LOUT+, and LOUT-, are biased at half-supply, no need DC voltage exists across the load. This eliminates the need for an output coupling capacitor which is required in a single supply, SE configuration.

Single-Ended Operation

Consider the single-supply SE configuration shown Application Circuit. A coupling capacitor is required to block the DC offset voltage from reaching the load. These capacitors can be quite large (approximately 33μF to 1000μF) so they tend to be expensive, occupy valuable PCB area, and have the additional drawback of limiting low-frequency performance of the system (refer to the Output Coupling Capacitor). The rules described still hold with the addition of the following relationship:

$$\frac{1}{C_{bypass} \times 125k\Omega} \leq \frac{1}{RiCi} \ll \frac{1}{RLC_c} \quad (1)$$

Output SE/BTL Operation

The ability of the APA2120/1 to easily switch between BTL and SE modes is one of its most important costs saving features. This feature eliminates the requirement for an additional headphone amplifier in applications where internal stereo speakers are driven in BTL mode but external headphone or speakers must be accommodated.

Application Descriptions (Cont.)

Output SE/BTL Operation (Cont.)

Internal to the APA2120/1, two separate amplifiers drive OUT+ and OUT- (see Figure 1). The SE/BTL input controls the operation of the follower amplifier that drives LOU- and ROU-.

- When SE/BTL is held low, the OP2 is turn on and the APA2120/1 is in the BTL mode.
- When SE/BTL is held high, the OP2 is in a high output impedance state, which configures the APA2120/1 as SE driver from OUT+. I_{DD} is reduced by approximately one-half in SE mode.

Control of the SE/BTL input can be a logic-level TTL source or a resistor divider network or the stereo headphone jack with switch pin as shown in Application Circuit.

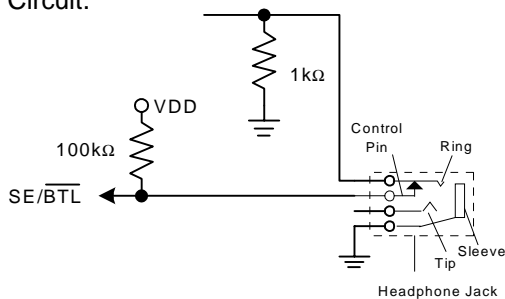

Figure 2: SE/BTL input selection by phonejack plug

In Figure 2, input SE/BTL operates as follows :

When the phonejack plug is inserted, the 1kΩ resistor is disconnected and the SE/BTL input is pulled high and enables the SE mode. When the input goes high, the OUT- amplifier is shutdown causing the speaker to mute. The OUT+ amplifier then drives through the output capacitor (C_c) into the headphone jack. When there is no headphone plugged into the system, the contact pin of the headphone jack is connected from the signal pin, the voltage divider set up by resistors 100kΩ and 1kΩ.

Output SE/BTL Operation (Cont.)

Resistor 1kΩ then pulls low the SE/BTL pin, enabling the BTL function.

Volume Control Function

APA2120/1 has an internal stereo volume control whose setting is a function of the DC voltage applied to the VOLUME input pin. The APA2120/1 volume control consists of 32 steps that are individually selected by a variable DC voltage level on the VOLUME control pin. The range of the steps, controlled by the DC voltage, are from 20dB to -80dB. Each gain step corresponds to a specific input voltage range, as shown in table. To minimize the effect of noise on the volume control pin, which can affect the selected gain level, hysteresis and clock delay are implemented. The amount of hysteresis corresponds to half of the step width, as shown in volume control graph.

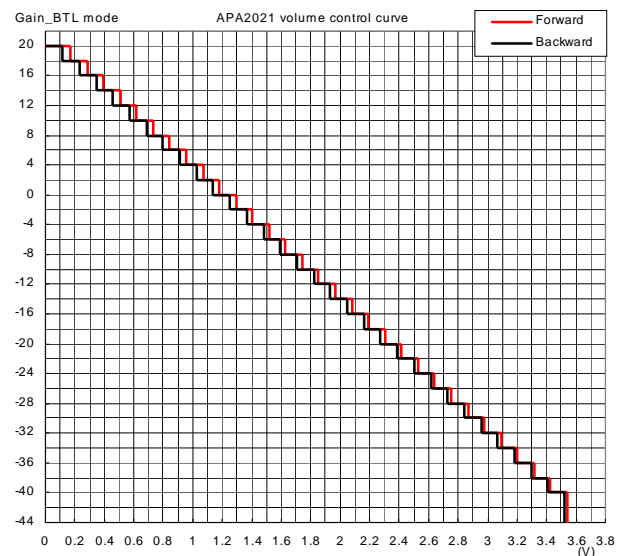

Figure 3: Gain setting vs VOLUME pin voltage

Application Descriptions (Cont.)

Volume Control Function (Cont.)

For highest accuracy, the voltage shown in the 'recommended voltage' column of the table is used to select a desired gain. This recommended voltage is exactly halfway between the two nearest transitions. The gain levels are 2dB/step from 20dB to -40dB in BTL mode, and the last step at -80dB as mute mode.

Input Resistance, R_i

The gain for each audio input of the APA2120/1 is set by the internal resistors (R_i and R_f) of volume control amplifier in inverting configuration.

$$SE\ Gain = A_v = -\frac{R_f}{R_i} \quad (2)$$

$$BTL\ Gain = -2 \times \frac{R_f}{R_i} \quad (3)$$

BTL mode operation brings the factor of 2 in the gain equation due to the inverting amplifier mirroring the voltage swing across the load. For the varying gain setting, APA2120/1 generates each input resistance on figure 4. The input resistance will affect the low frequency performance of audio signal. The minimum input resistance is 10k Ω when gain setting is 20dB and the resistance will ramp up when close loop gain below 20dB. The input resistance has wide variation (+/-10%) caused by process variation.

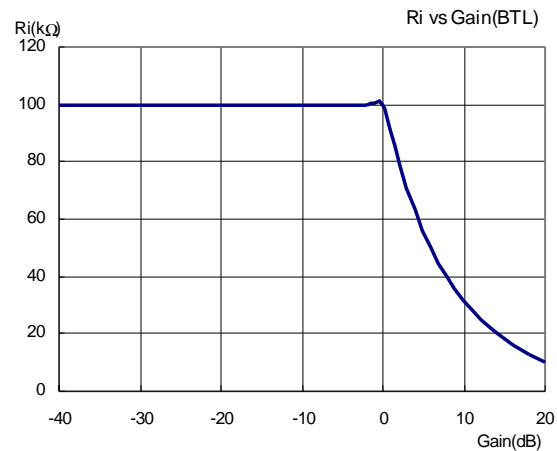

Figure 4: Input resistance vs Gain setting

Input Capacitor, C_i

In the typical application an input capacitor, C_i , is required to allow the amplifier to bias the input signal to the proper DC level for optimum operation. In this case, C_i and the minimum input impedance R_i (10k Ω) form a high-pass filter with the corner frequency determined in the follow equation :

$$F_c(\text{highpass}) = \frac{1}{2\pi \times 10k\Omega \times C_i} \quad (4)$$

The value of C_i is important to consider as it directly affects the low frequency performance of the circuit. Consider the example where R_i is 10k Ω and the specification calls for a flat bass response down to 100Hz. Equation is reconfigured as follow :

$$C_i = \frac{1}{2\pi \times 10k\Omega \times f_c} \quad (5)$$

Consider to input resistance variation, the C_i is 0.16 μ F so one would likely choose a value in the range of 0.22 μ F to 1.0 μ F.

Application Descriptions (Cont.)

Input Capacitor, Ci (Cont.)

A further consideration for this capacitor is the leakage path from the input source through the input network (R_i+R_f , C_i) to the load. This leakage current creates a DC offset voltage at the input to the amplifier that reduces useful headroom, especially in high gain applications. For this reason a low-leakage tantalum or ceramic capacitor is the best choice. When polarized capacitors are used, the positive side of the capacitor should face the amplifier input in most applications as the DC level there is held at $V_{DD}/2$, which is likely higher than the source DC level. Please note that it is important to confirm the capacitor polarity in the application.

Effective Bypass Capacitor, Cbypass

As other power amplifiers, proper supply bypassing is critical for low noise performance and high power supply rejection.

The capacitors located on both the bypass and power supply pins should be as close to the device as possible. The effect of a larger bypass capacitor will improve PSRR due to increased supply stability. Typical applications employ a 5V regulator with 1.0 μ F and a 0.1 μ F bypass capacitor as supply filtering. This does not eliminate the need for bypassing the supply nodes of the APA2120/1. The selection of bypass capacitors, especially Cbypass, is thus dependent upon desired PSRR requirements, click and pop performance.

On the chip, there are three bypass pins for used, and they are tied together in the internal circuit.

Effective Bypass Capacitor, Cbypass (Cont.)

The effective capacitance is the $C_{bypass}=(C_b//C_{Lbypass})/(C_b//C_{Rbypass})$. When absolute minimum cost and/or component space is required, one bypass capacitor can be used.

To avoid start-up pop noise occurred, the bypass voltage should rise slower than the input bias voltage and the relationship shown in equation (6) should be maintained.

$$\frac{1}{C_{bypass} \times 125k\Omega} \ll \frac{1}{100k\Omega \times C_i} \quad (6)$$

The bypass capacitor is fed thru from a 125k Ω resistor inside the amplifier and the 100k Ω is maximum input resistance of ($R_i+ R_f$). Bypass capacitor, C_b , values of 3.3 μ F to 10 μ F ceramic or tantalum low-ESR capacitors are recommended for the best THD and noise performance.

The bypass capacitance also effects to the start up time. It is determined in the following equation :

$$T_{start\ up} = 5 \times (C_{bypass} \times 125K\Omega) \quad (7)$$

Output Coupling Capacitor, Cc

In the typical single-supply SE configuration, an output coupling capacitor (C_c) is required to block the DC bias at the output of the amplifier thus preventing DC currents in the load. As with the input coupling capacitor, the output coupling capacitor and impedance of the load form a high-pass filter governed by equation.

$$F_c(\text{highpass}) = \frac{1}{2\pi R_L C_c} \quad (8)$$

Application Descriptions (Cont.)

Output Coupling Capacitor, C_c (Cont.)

For example, a 330 μ F capacitor with an 8 Ω speaker would attenuate low frequencies below 60.6Hz. The main disadvantage, from a performance standpoint, is the load impedance is typically small, which drives the low-frequency corner higher degrading the bass response. Large values of C_c are required to pass low frequencies into the load.

Power Supply Decoupling, C_s

The APA2120/1 provides PV_{DD} and V_{DD} two independent power inputs for used. PV_{DD} is used for power amplifier only and V_{DD} is used for volume control amplifier and internal circuit excepting power amplifier. The APA2120/1 is a high-performance CMOS audio amplifier that requires adequate power supply decoupling to ensure the output total harmonic distortion (THD) is as low as possible. Power supply decoupling also prevents the oscillations causing by long lead length between the amplifier and the speaker. The optimum decoupling is achieved by using two different type capacitors that target on different type of noise on the power supply leads.

For higher frequency transients, spikes, or digital hash on the line, a good low equivalent-series-resistance (ESR) ceramic capacitor, typically 0.1 μ F placed as close as possible to the device V_{DD} and PV_{DD} lead works best. For filtering lower-frequency noise signals, a large aluminum electrolytic capacitor of 10 μ F or greater placed near the audio power amplifier is recommended.

Optimizing Depop Circuitry

Circuitry has been included in the APA2120/1 to minimize the amount of popping noise at power-up and when coming out of shutdown mode. Popping occurs whenever a voltage step is applied to the speaker. In order to eliminate clicks and pops, all capacitors must be fully discharged before turn-on. Rapid on/off switching of the device or the shutdown function will cause the click and pop circuitry.

The value of C_i will also affect turn-on pops. (Refer to Effective Bypass Capacitance) The bypass voltage ramp up should be slower than input bias voltage. Although the bypass pin current source cannot be modified, the size of C_{bypass} can be changed to alter the device turn-on time and the amount of clicks and pops. By increasing the value of C_{bypass} , turn-on pop can be reduced. However, the tradeoff for using a larger bypass capacitor is to increase the turn-on time for this device. There is a linear relationship between the size of C_{bypass} and the turn-on time. In a SE configuration, the output coupling capacitor, C_c , is of particular concern.

This capacitor discharges through the internal 10k Ω resistors. Depending on the size of C_c , the time constant can be relatively large. To reduce transients in SE mode, an external 1k Ω resistor can be placed in parallel with the internal 10k Ω resistor. The tradeoff for using this resistor is an increase in quiescent current. In the most cases, choosing a small value of C_i in the range of 0.33 μ F to 1 μ F, C_b being equal to 4.7 μ F and an external 1k Ω resistor should be placed in parallel with the internal 10k Ω resistor should produce a virtually clickless and popless turn-on.

Application Descriptions (Cont.)

Optimizing Depop Circuitry (Cont.)

A high gain amplifier intensifies the problem as the small delta in voltage is multiplied by the gain. So it is advantageous to use low-gain configurations.

Shutdown Function

In order to reduce power consumption while not in use, the APA2120/1 contains a shutdown pin to externally turn off the amplifier bias circuitry. This shutdown feature turns the amplifier off when a logic low is placed on the $\overline{\text{SHUTDOWN}}$ pin. The trigger point between a logic high and logic low level is typically 2.0V. It is best to switch between ground and the supply V_{DD} to provide maximum device performance.

By switching the $\overline{\text{SHUTDOWN}}$ pin to low, the amplifier enters a low-current state, $I_{DD} < 50\mu\text{A}$. APA2120/1 is in shutdown mode, except PC-BEEP detect circuit.

On normal operating, $\overline{\text{SHUTDOWN}}$ pin pull to high level to keeping the IC out of the shutdown mode. The $\overline{\text{SHUTDOWN}}$ pin should be tied to a definite voltage to avoid unwanted state changes.

Input HP/ $\overline{\text{LINE}}$ Operation

APA2120/1 amplifier has two separate inputs for each of the left and right stereo channels. The APA2120 and APA2121 have different control input by SE/ $\overline{\text{BTL}}$ and HP/ $\overline{\text{LINE}}$, respectively.

APA2120 internal multiplexor is selected by SE/ $\overline{\text{BTL}}$ control input. Refer to the 'Output SE/ $\overline{\text{BTL}}$ Operation', the voltage divider of 100k Ω and 1k Ω sets the voltage at the SE/ $\overline{\text{BTL}}$ pin to be approximately 50mV when no phonejack plugged into the system.

Input HP/ $\overline{\text{LINE}}$ Operation (Cont.)

This logic-low voltage at the SE/ $\overline{\text{BTL}}$ pin makes APA2120 into LINE input mode operation. It becomes HP input mode when phonejack plugged.

An internal multiplexor selects the input to connect to the amplifier based on the state of the HP/ $\overline{\text{LINE}}$ pin of the APA2121.

- To select the LINE inputs, set HP/ $\overline{\text{LINE}}$ pin to low level.
- To enable the HP(headphone) inputs, set HP/ $\overline{\text{LINE}}$ pin to high level.

As APA2121, HP/ $\overline{\text{LINE}}$ input multiplexor, and SE/ $\overline{\text{BTL}}$ output operating mode have independent control paths, which can be used for multiple audio input system. This function will be the same as APA2120 when HP/ $\overline{\text{LINE}}$ and SE/ $\overline{\text{BTL}}$ are tied together.

PC-BEEP Detection

APA2120/1 integrates a BEEP detect circuit for NOTEBOOK PC. When BEEP signal is provided on PCBEEP input pin, the BEEP mode is active. APA2120/1 will force to BTL mode and the internal gain is fixed at -10dB. The PCBEEP signal becomes the amplifier input signal and plays on the speaker without coupling capacitor. It will be out of shutdown mode whenever BEEP mode is enabled. APA2120/1 will return to previous setting when it is out of BEEP mode. The input impedance is 100k Ω on PCBEEP input pin.

APA2120 provides extra PCBEN control input signal to force IC into BEEP mode. The BEEP mode will be enabled when PCBEN goes to high level. When BEEP mode is overridden, the signal from PCBEEP will pass to speaker directly.

Application Descriptions (Cont.)

Clock Generator

APA2120/1 integrates a clock block to avoid volume control function abnormal when VOLUME control signal with spike or noise. APA2120/1 changes each step of volume gain after four clock cycles to make sure control signal ready. It provides 130kHz frequency if no capacitor place on CLK pin to ground. The larger capacitance will slow down the and clock frequency. A capacitor 33nF between CLK to ground and will generates 147Hz frequency on CLK pin.

BTL Amplifier Efficiency

An easy-to-use equation to calculate efficiency starts out as being equal to the ratio of power from the power supply to the power delivered to the load.

The following equations are the basis for calculating amplifier efficiency.

$$\text{Efficiency} = \frac{P_O}{P_{SUP}} \quad (9)$$

Where :

$$P_O = \frac{V_{ORMS} \times V_{ORMS}}{R_L} = \frac{V_P \times V_P}{2R_L} \quad (10)$$

$$V_{ORMS} = \frac{V_P}{\sqrt{2}} \quad (10)$$

$$P_{SUP} = V_{DD} \times I_{DDAVG} = V_{DD} \times \frac{2V_P}{\pi R_L} \quad (11)$$

Efficiency of a BTL configuration :

$$\frac{P_O}{P_{SUP}} = \left(\frac{V_P \times V_P}{2R_L} \right) / \left(V_{DD} \times \frac{2V_P}{\pi R_L} \right) = \frac{\pi V_P}{4V_{DD}} \quad (12)$$

Table 1 calculates efficiencies for four different output power levels.

BTL Amplifier Efficiency (Cont.)

Note that the efficiency of the amplifier is quite low for lower power levels and rises sharply as power to the load is increased resulting in a nearly flat internal power dissipation over the normal operating range. Note that the internal dissipation at full output power is less than in the half power range. Calculating the efficiency for a specific system is the key to proper power supply design. For a stereo 1W audio system with 8Ω loads and a 5V supply, the maximum draw on the power supply is almost 3W.

A final point to remember about linear amplifiers (either SE or BTL) is how to manipulate the terms in the efficiency equation to utmost advantage when possible. Note that in equation, V_{DD} is in the denominator. This indicates that as V_{DD} goes down, efficiency goes up. In other words, use the efficiency analysis to choose the correct supply voltage and speaker impedance for the application.

P _O (W)	Efficiency (%)	I _{DD} (A)	V _{PP} (V)	P _D (W)
0.25	31.25	0.16	2.00	0.55
0.50	47.62	0.21	2.83	0.55
1.00	66.67	0.30	4.00	0.5
1.25	78.13	0.32	4.47	0.35

**High peak voltages cause the THD to increase.

Table 1. Efficiency Vs Output Power in 5-V/8Ω BTL Systems

Application Descriptions (Cont.)

Power Dissipation

Whether the power amplifier is operated in BTL or SE modes, power dissipation is a major concern. In equation13 states the maximum power dissipation point for a SE mode operating at a given supply voltage and driving a specified load.

$$\text{SE mode : } P_{D,MAX} = \frac{V_{DD}^2}{2\pi^2 R_L} \quad (13)$$

In BTL mode operation, the output voltage swing is doubled as in SE mode. Thus the maximum power dissipation point for a BTL mode operating at the same given conditions is 4 times as in SE mode.

$$\text{BTL mode : } P_{D,MAX} = \frac{4V_{DD}^2}{2\pi^2 R_L} \quad (14)$$

Since the APA2120/1 is a dual channel power amplifier, the maximum internal power dissipation is 2 times that both of equations depending on the mode of operation. Even with this substantial increase in power dissipation, the APA2120/1 does not require extra heatsink. The power dissipation from equation14, assuming a 5V-power supply and an 8Ω load, must not be greater than the power dissipation that results from the equation15 :

$$P_{D,MAX} = \frac{T_{J,MAX} - T_A}{\theta_{JA}} \quad (15)$$

For TSSOP-24 package with thermal pad, the thermal resistance (θ_{JA}) is equal to 45°C/W.

Since the maximum junction temperature ($T_{J,MAX}$) of APA2120/1 is 150°C and the ambient temperature (T_A) is defined by the power system design, the maximum power dissipation which the IC package is able to handle can be obtained from equation16.

Power Dissipation (Cont.)

Once the power dissipation is greater than the maximum limit ($P_{D,MAX}$), either the supply voltage (V_{DD}) must be decreased, the load impedance (R_L) must be increased or the ambient temperature should be reduced.

Thermal Pad Considerations

The thermal pad must be connected to ground. The package with thermal pad of the APA2120/1 requires special attention on thermal design. If the thermal design issues are not properly addressed, the APA2120/1 4Ω will go into thermal shutdown when driving a 4Ω load.

The thermal pad on the bottom of the APA2120/1 should be soldered down to a copper pad on the circuit board. Heat can be conducted away from the thermal pad through the copper plane to ambient. If the copper plane is not on the top surface of the circuit board, 8 to 10 vias of 13 mil or smaller in diameter should be used to thermally couple the thermal pad to the bottom plane.

For good thermal conduction, the vias must be plated through and solder filled. The copper plane used to conduct heat away from the thermal pad should be as large as practical.

If the ambient temperature is higher than 25°C, a larger copper plane or forced-air cooling will be required to keep the APA2120/1 junction temperature below the thermal shutdown temperature (150°C). In higher ambient temperature, higher airflow rate and/or larger copper area will be required to keep the IC out of thermal shutdown.

Packaging Information

TSSOP/ TSSOP-P (Reference JEDEC Registration MO-153)

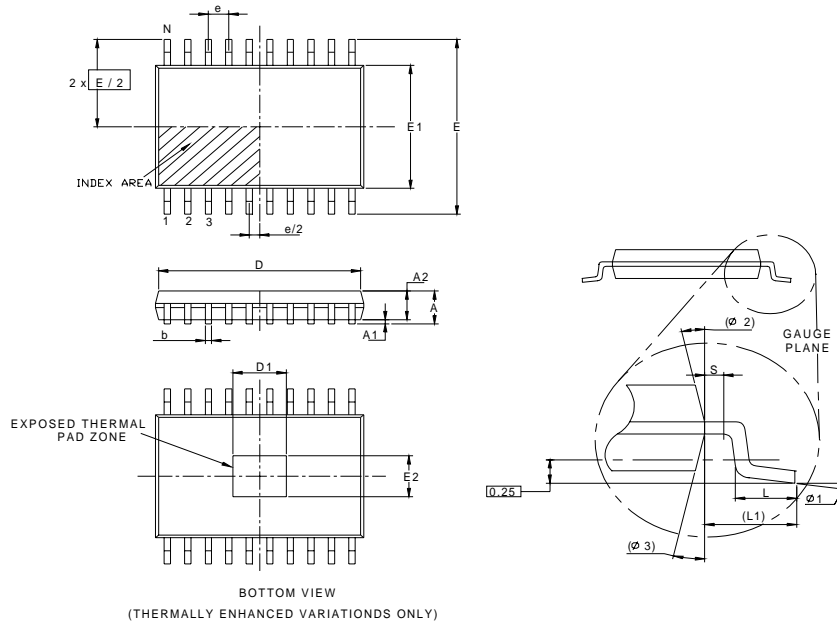

Dim	Millimeters		Inches	
	Min.	Max.	Min.	Max.
A		1.2		0.047
A1	0.00	0.15	0.000	0.006
A2	0.80	1.05	0.031	0.041
b	0.19	0.3	0.007	0.011
D	6.4 (N=20PIN) 7.7 (N=24PIN) 9.6 (N=28PIN)	6.6 (N=20PIN) 7.9 (N=24PIN) 9.8 (N=28PIN)	0.252 (N=20PIN) 0.303 (N=24PIN) 0.378 (N=28PIN)	0.260 (N=20PIN) 0.311 (N=24PIN) 0.386 (N=28PIN)
D1	4.2 BSC (N=20PIN) 4.7 BSC (N=24PIN) 3.8 BSC (N=28PIN)		0.165 BSC (N=20PIN) 0.188 BSC (N=24PIN) 0.150 BSC (N=28PIN)	
e	0.65 BSC		0.026 BSC	
E	6.40 BSC		0.252 BSC	
E1	4.30	4.50	0.169	0.177
E2	3.0 BSC (N=20PIN) 3.2 BSC (N=24PIN) 2.8 BSC (N=28PIN)		0.118 BSC (N=20PIN) 0.127 BSC (N=24PIN) 0.110 BSC (N=28PIN)	
L	0.45	0.75	0.018	0.030
L1	1.0 REF		0.039 REF	
R	0.09		0.004	
R1	0.09		0.004	
S	0.2		0.008	
phi1	0°	8°	0°	8°
phi2	12° REF		12° REF	

Physical Specifications

Terminal Material	Solder-Plated Copper (Solder Material : 90/10 or 63/37 SnPb), 100%Sn
Lead Solderability	Meets EIA Specification RSI86-91, ANSI/J-STD-002 Category 3.

Reflow Condition (IR/Convection or VPR Reflow)

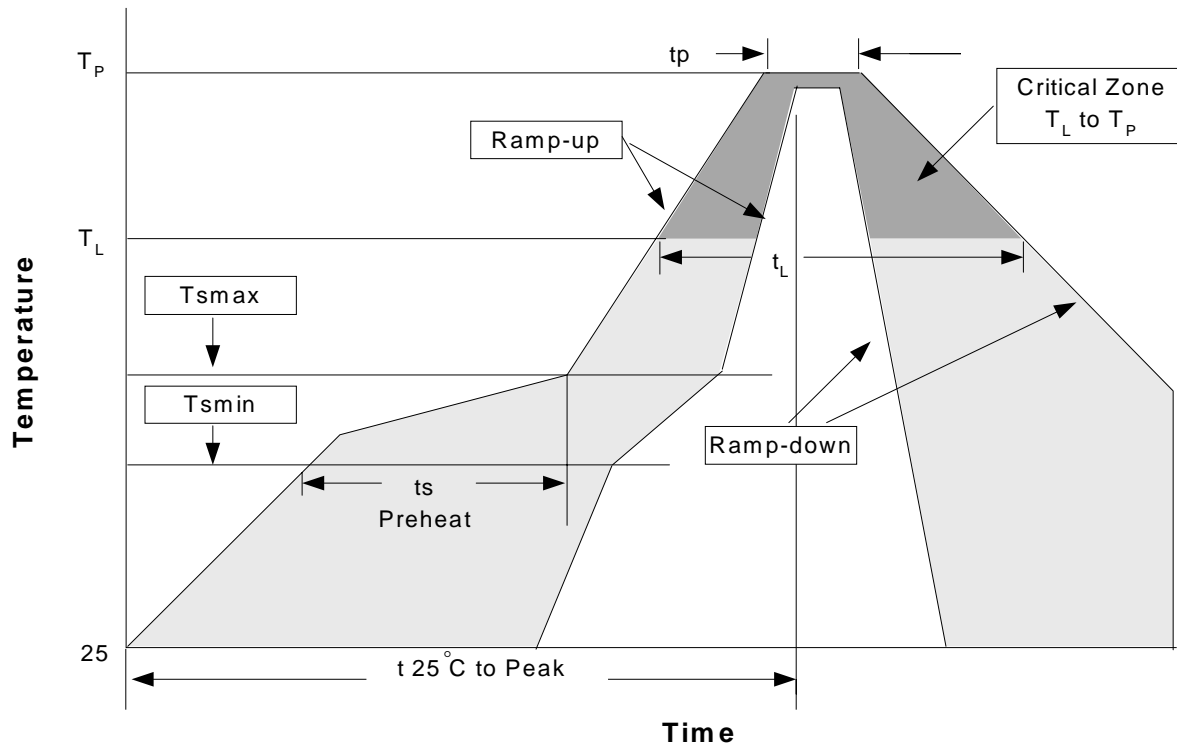

Classification Reflow Profiles

Profile Feature	Sn-Pb Eutectic Assembly		Pb-Free Assembly	
	Large Body	Small Body	Large Body	Small Body
Average ramp-up rate (T_L to T_P)	3°C/second max.		3°C/second max.	
Preheat				
- Temperature Min (T_{smin})	100°C		150°C	
- Temperature Mix (T_{smax})	150°C		200°C	
- Time (min to max)(t_s)	60-120 seconds		60-180 seconds	
T_{smax} to T_L				
- Ramp-up Rate			3°C/second max	
T_{smax} to T_L				
- Temperature(T_L)	183°C		217°C	
- Time (t_L)	60-150 seconds		60-150 seconds	
Peak Temperature(T_p)	225 +0/-5°C	240 +0/-5°C	245 +0/-5°C	250 +0/-5°C
Time within 5°C of actual Peak Temperature(t_p)	10-30 seconds	10-30 seconds	10-30 seconds	20-40 seconds
Ramp-down Rate	6°C/second max.		6°C/second max.	
Time 25°C to Peak Temperature	6 minutes max.		8 minutes max.	

Note: All temperatures refer to topside of the package. Measured on the body surface.

Reliability Test Program

Test item	Method	Description
SOLDERABILITY	MIL-STD-883D-2003	245°C, 5 SEC
HOLT	MIL-STD-883D-1005.7	1000 Hrs Bias @ 125°C
PCT	JESD-22-B,A102	168 Hrs, 100%RH, 121°C
TST	MIL-STD-883D-1011.9	-65°C~150°C, 200 Cycles
ESD	MIL-STD-883D-3015.7	VHBM > 2KV, VMM > 200V
Latch-Up	JESD 78	10ms, $1_{tr} > 100mA$

Carrier Tape & Reel Dimensions

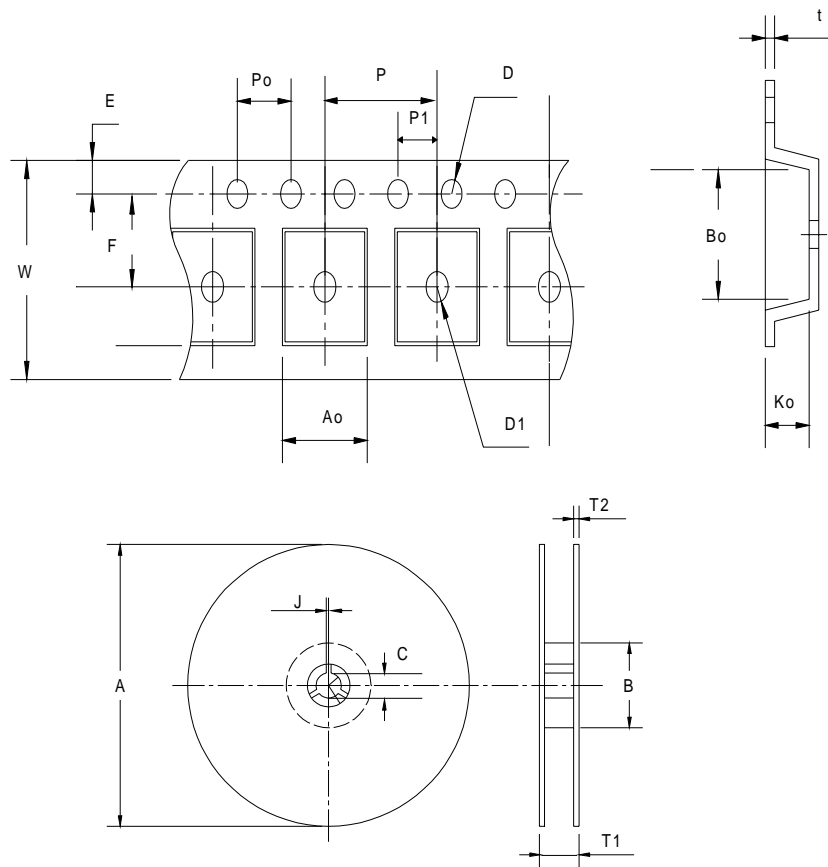

Application	A	B	C	J	T1	T2	W	P	E
TSSOP- 24	330 ±1	100 ref	13 ±0.5	2 ±0.5	16.4 ±0.2	2 ±0.2	16 ±0.3	12 ±0.1	1.75 ±0.1
	F	D	D1	Po	P1	Ao	Bo	Ko	t
	7.5 ±0.1	1.5 ±0.1	1.5 min	4.0 ±0.1	2.0 ±0.1	6.9 ±0.1	8.3 ±0.1	1.5 ±0.1	0.3 ±0.05

(mm)

Cover Tape Dimensions

Application	Carrier Width	Cover Tape Width	Devices Per Reel
TSSOP- 24	16	21.3	2000

Customer Service

Anpec Electronics Corp.

Head Office :

5F, No. 2 Li-Hsin Road, SBIP,

Hsin-Chu, Taiwan, R.O.C.

Tel : 886-3-5642000

Fax : 886-3-5642050

Taipei Branch :

7F, No. 137, Lane 235, Pac Chiao Rd.,

Hsin Tien City, Taipei Hsien, Taiwan, R. O. C.

Tel : 886-2-89191368

Fax : 886-2-89191369