

High Power Chip Resistors

CRH series

MERITEK

FEATURE

- Small size and light weight
- Highly reliable multilayer electrode construction
- Compatible with all soldering process
- Long side terminations



PART NUMBERING SYSTEM

CRH 0603 H 102 J
 (1) (2) (3) (4) (5)



No	item	Digit	Specification
(1)	Meritek Series	CRH	High Power Chip Resistors
(2)	Dimension	0603	0402 0603 0805 1206 1210 2010 2512
(3)	Function Code	H	H: High Power U: Ultra High Power
(4)	Resistance	102	5% 3 digits. First 2 are significant, Third is multiplier (10 ^x)
			1% 4 digits. First 3 are significant, Forth is multiplier (10 ^x)
(5)	Tolerance	J	F: ±1% J: ±5%

ELECTRICAL SPECIFICATION

Type	Power Rating at 70°C	Operating Temp. Range	Max Operating Voltage	Max Overload Voltage	Resistance Range		TCR (PPM/°C)
					±1% (E24,E96)	±5% (E24)	
CRH0402	1/8W	-55 ~ +155°C	50V	100V	1Ω~9.76Ω 10Ω~1MΩ 0Ω(<20mΩ)	±200 ±100 -	
	Jumper: 1.5A						
CRH0603	1/4W		75V	150V			
	Jumper: 2A						
CRH0805	1/3W		150V	300V			
	Jumper: 2.5A						
CRH1206	1/3 *1/2W		200V	400V			
	Jumper: 3.5A						
CRH1210	1/2 *3/4W	200V	400V				
	Jumper: 5A						
CRH2010	1W	200V	400V				
	Jumper: 6A						
CRH2512	2W	200V	500V				
	Jumper: 7A						

Notes:

- *: Ultra High Power
- Operating Voltage = \sqrt{PR} or Max. Operating Voltage listed above, whichever is lower.
- Overload Voltage = $2.5\sqrt{PR}$ or Max. Overload Voltage listed above, whichever is lower.

High Power Chip Resistors

CRH series

MERITEK

CONSTRUCTION

1	Alumina Substrate	4	Edge Electrode	7	Resistor Layer
2	Bottom Electrode	5	Barrier Layer	8	Primary Overcoat
3	Top Electrode	6	External Electrode	9	Secondary Overcoat

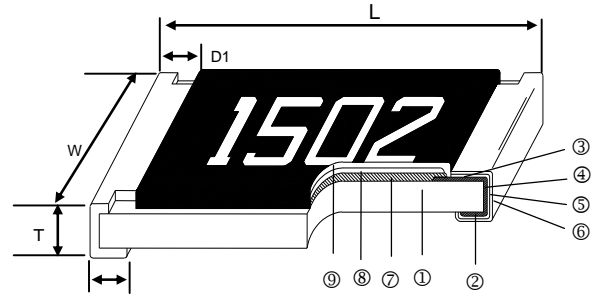

DIMENSION

Unit: mm

Type	Size (Inch)	L	W	T	D1	D2	Weight (g) (1000pcs)
CRH	0402	1.00±0.05	0.50±0.05	0.35±0.05	0.20±0.10	0.20±0.10	0.62
CRH	0603	1.60±0.10	0.80±0.10	0.45±0.10	0.30±0.20	0.30±0.20	2.042
CRH	0805	2.00±0.10	1.25±0.10	0.50±0.10	0.35±0.20	0.40±0.20	4.368
CRH	1206	3.10±0.10	1.55±0.10	0.55±0.10	0.50±0.25	0.50±0.20	8.947
CRH	1210	3.10±0.10	2.60±0.15	0.55±0.10	0.50±0.25	0.50±0.20	15.959
CRH	2010	5.00±0.10	2.50±0.15	0.55±0.10	0.60±0.25	0.50±0.20	24.241
CRH	2512	6.35±0.10	3.10±0.15	0.55±0.10	0.60±0.25	0.50±0.20	39.448

DERATING CURVE

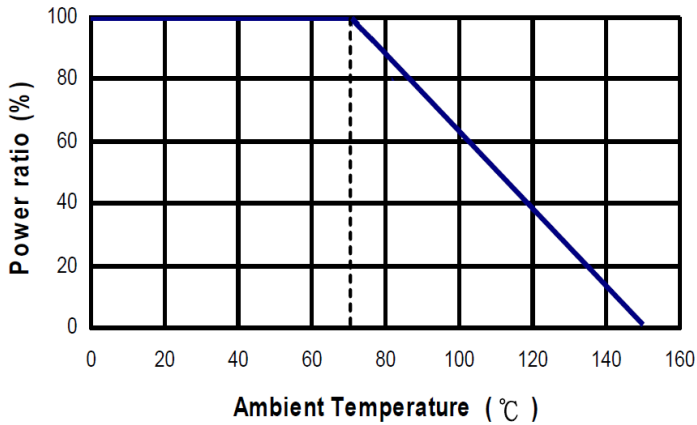

RECOMMEND LAND PATTERN

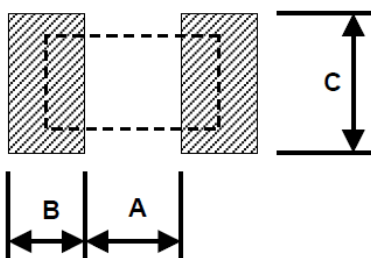

Size	A	B	C
0402	0.50	0.45	0.60
0603	0.90	0.60	0.90
0805	1.20	0.70	1.30
1206	2.00	0.90	1.60
1210	2.00	0.90	2.80
2010	3.80	0.90	2.80
2512	3.80	1.60	3.50

ENVIRONMENTAL CHARACTERISTICS

Item	Requirement			Test Method
	±1% and Below	±5%	Jumper	
Temperature Coefficient of Resistance (T.C.R.)	As Spec.			JIS-C-5201-1 4.8 IEC-60115-1 4.8 -55°C~+125°C, 25°C is the reference temperature
Short Time Overload	±(1.0%+0.05Ω)	±(2.0%+0.05Ω)	<50mΩ	JIS-C-5201-1 4.13 IEC-60115-1 4.13 RCWV*2.5 or Max. overload voltage for 5 seconds, 2 seconds for high power series
Insulation Resistance	≥10G			JIS-C-5201-1 4.6 IEC-60115-1 4.6 Max. overload voltage for 1 minute
Endurance	±(1.0%+0.10Ω)	±(2.0%+0.10Ω)	<100mΩ	JIS-C-5201-1 4.25 IEC-60115-1 4.25.1 70±2°C, Max. working voltage for 1000 hrs with 1.5 hrs "ON" and 0.5 hrs "OFF"
Damp Heat with Load	±(1.0%+0.10Ω)	±(2.0%+0.10Ω)	<100mΩ	JIS-C-5201-1 4.24 40±2°C, 90~95% R.H. Max. working voltage for 1000 hrs with 1.5 hrs "ON" and 0.5 hrs "OFF"
Dry Heat	±(1.0%+0.05Ω)	±(1.5%+0.10Ω)	<50mΩ	JIS-C-5201-1 4.23 IEC-60115-1 2.23.2 at +125/+155°C for 1000 hrs
Bending Strength	±(1.0%+0.05Ω)	±(1.0%+0.05Ω)	<50mΩ	JIS-C-5201-1 4.33 IEC-60115-1 4.33 Bending once for 5 seconds 2010, 2512 sizes: 2mm Other sizes: 3mm
Solderability	95% min. coverage			JIS-C-5201-1 4.17 IEC-60115-1 4.17 245±5°C for 3 seconds
Resistance to Soldering Heat	±(0.5%+0.05Ω)	±(1.0%+0.05Ω)	<50mΩ	JIS-C-5201-1 4.18 IEC-60115-1 4.18 260±5°C for 10 seconds
Voltage Proof	No breakdown or flashover			JIS-C-5201-1 4.7 IEC-60115-1 4.7 1.42 times RCWV (RMS) for 1 minute
Leaching	Individual leaching area ≤5% Total leaching area ≤ 10%			JIS-C-5201-1 4.18 IEC-60068-2-58 8.2.1 260±5°C for 30 seconds
Rapid Change of Temperature	±(0.5%+0.05Ω)	±(1.0%+0.05Ω)	<50mΩ	JIS-C-5201-1 4.19 IEC-60115-1 4.19 -55°C to +125/+155°C, 5 cycles

Storage Temperature: 15~28°C; Humidity < 80%RH

SOLDERING CONDITION

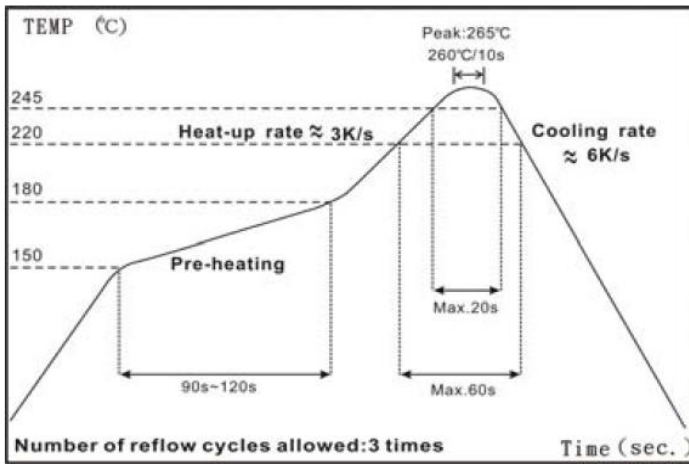

IR REFLOW Soldering

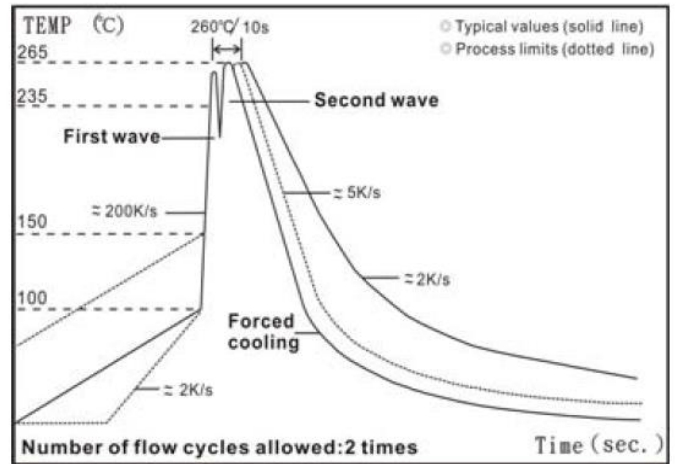

Wave Soldering (Flow Soldering)

- Time of IR reflow soldering at maximum temperature point 260°C : 10s
- Time of wave soldering at maximum temperature point 260°C : 10s
- Time of soldering iron at maximum temperature point 410°C : 5s

PACKAGING

Reel Specifications & Package Quantity

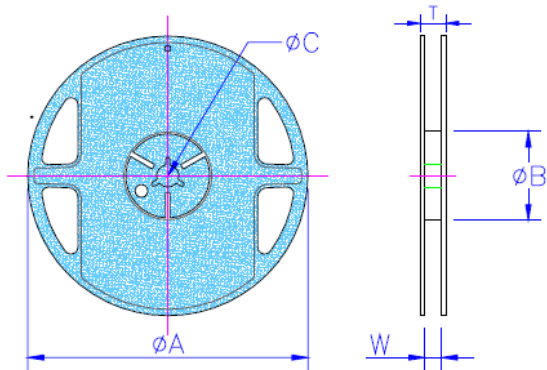

Unit: mm

Size	Packaging Quantity	Tape Width	Reel Diameter	ϕA	ϕB	ϕC	W	T	
402	Paper	10K	8mm	7 inch	178.5 \pm 1.5	60(+1/-0)	13.0 \pm 0.2	9.0 \pm 0.5	12.5 \pm 0.5
		20K	8mm	10 inch	254 \pm 1.0	100 \pm 0.5	13.0 \pm 0.2	9.5 \pm 0.5	13.5 \pm 0.5
		40K	8mm	13 inch	330 \pm 1.0	100 \pm 0.5	13.0 \pm 0.2	9.5 \pm 0.5	13.5 \pm 0.5
0603 0805 1206 1210	paper	5K	8mm	7 inch	178.5 \pm 1.5	60(+1/-0)	13.0 \pm 0.2	9.0 \pm 0.5	12.5 \pm 0.5
		10K	8mm	10 inch	254 \pm 1.0	100 \pm 0.5	13.0 \pm 0.2	9.5 \pm 0.5	13.5 \pm 0.5
		20K	8mm	13 inch	330 \pm 1.0	100 \pm 0.5	13.0 \pm 0.2	9.5 \pm 0.5	13.5 \pm 0.5
2010	Embossed	4K	12mm	7 inch	178.5 \pm 1.5	60(+1/-0)	13.0 \pm 0.5	13.0 \pm 0.5	15.5 \pm 0.5
2512		8K	12mm	10 inch	250 \pm 1.0	62 \pm 0.5	13.0 \pm 0.5	12.5 \pm 0.5	16.5 \pm 0.5

PACKAGING (Continued)

Paper Tape Specifications

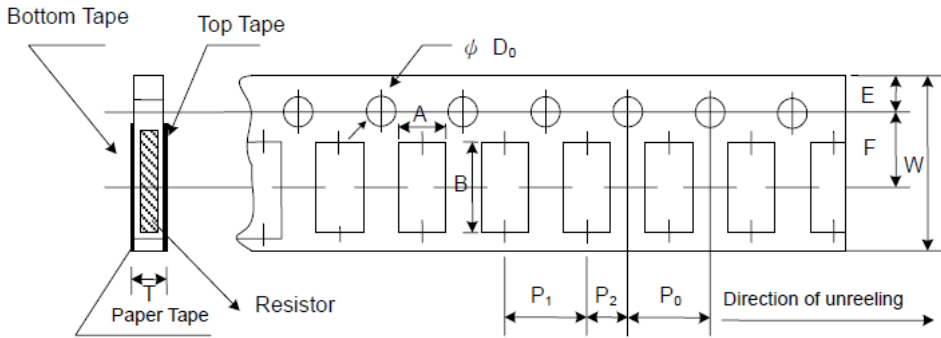

Unit: mm

Size	A	B	W	E	F	P ₀	P ₁	P ₂	ΦD ₀	T
0402	0.65±0.10	1.15±0.10	8.0±0.20	1.75±0.10	3.50±0.05	4.00±0.10	2.00±0.05	2.00±0.05	1.50+0.1,-0	0.45±0.10
0603	1.10±0.10	1.90±0.10	8.0±0.20	1.75±0.10	3.50±0.05	4.00±0.10	4.00±0.05	2.00±0.05	1.50+0.1,-0	0.70±0.10
0805	1.60±0.10	2.40±0.20	8.0±0.20	1.75±0.10	3.50±0.05	4.00±0.10	4.00±0.05	2.00±0.05	1.50+0.1,-0	0.85±0.10
1206	1.90±0.10	3.50±0.20	8.0±0.20	1.75±0.10	3.50±0.05	4.00±0.10	4.00±0.05	2.00±0.05	1.50+0.1,-0	0.85±0.10
1210	2.90±0.10	3.50±0.20	8.0±0.20	1.75±0.10	3.50±0.05	4.00±0.10	4.00±0.05	2.00±0.05	1.50+0.1,-0	0.85±0.10

Embossed Plastic Tape Specification

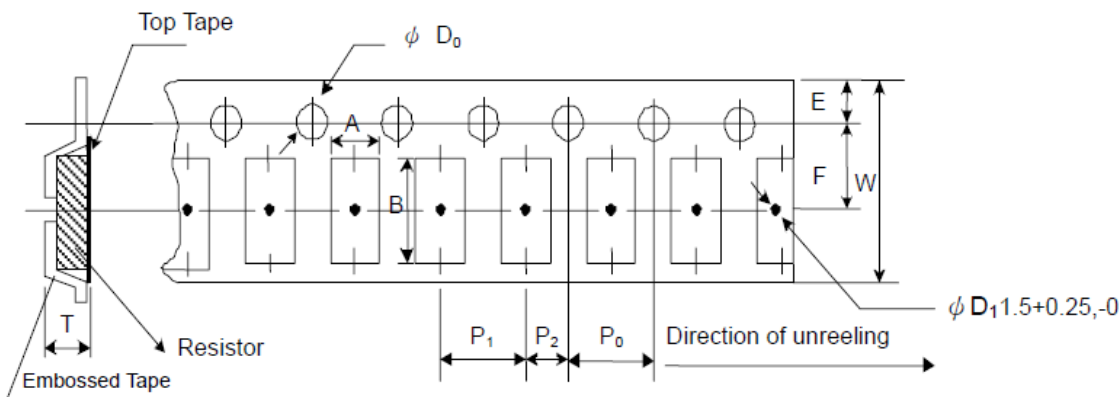

Size	A	B	W	E	F	P ₀	P ₁	P ₂	ΦD ₀	T
2010	2.8±0.20	5.5±0.20	12.0±0.30	1.75±0.10	5.5±0.05	4.00±0.10	4.00±0.10	2.00±0.05	1.50+0.1,-0	1.2 ⁺⁰
2512	3.5±0.20	6.7±0.20	12.0±0.30	1.75±0.10	5.5±0.05	4.00±0.10	4.00±0.10	2.00±0.05	1.50+0.1,-0	1.2 ⁺⁰