

PART NUMBER	ITEM ① BODY	ITEM ② BASE	ITEM ③ CONTACT	ITEM ④ INSULATOR
125-2701-201	BERYLLIUM COPPER GOLD PL .00005 MIN OVER NICKEL PL.00005 MIN OVER COPPER PL.00005 MIN	BRASS GOLD PL .00003 MIN OVER NICKEL PL.00005 MIN OVER COPPER PL.00005 MIN	BERYLLIUM COPPER GOLD PL .00005 MIN OVER NICKEL PL.00005 MIN OVER COPPER PL.00005 MIN	TEFLON

DRAWING NO. 125-2701-201	
<b>REVISIONS</b>	
1	RELEASE
4-8-2013	R S L M ECO-13-0089

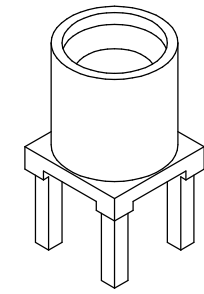

10:1

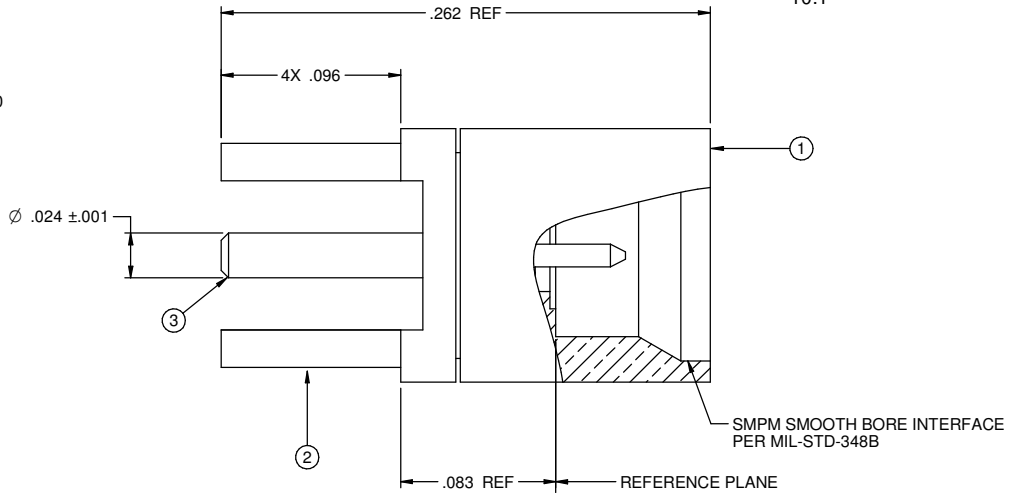
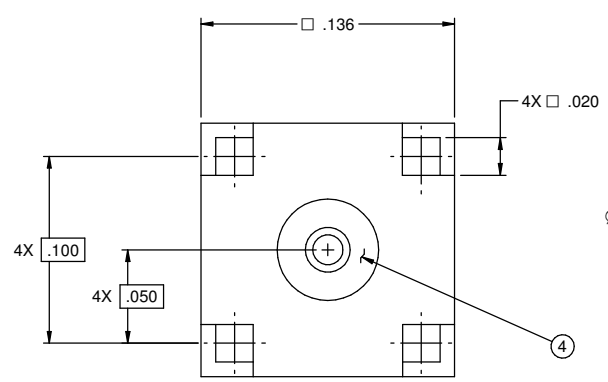

SMPM SMOOTH BORE INTERFACE  
PER MIL-STD-348B

**SPECIFICATION:**

IMPEDANCE: 50 OHMS  
 FREQUENCY RANGE: 0-40 GHz  
 VSWR: DEPENDANT ON APPLICATION  
 WORKING VOLTAGE: 325 VRMS MAX AT SEA LEVEL  
 DIELECTRIC WITHSTANDING VOLTAGE: 325 VRMS MIN AT SEA LEVEL  
 INSULATION RESISTANCE: 5000 MEGOHM MIN  
 CONTACT RESISTANCE:  
 CENTER CONTACT - INITIAL 6 MILLIOHM MAX, AFTER ENVIRONMENTAL NOT APPLICABLE  
 OUTER CONDUCTOR - INITIAL 2 MILLIOHM MAX, AFTER ENVIRONMENTAL NOT APPLICABLE  
 RF LEAKAGE: NOT APPLICABLE

**MECHANICAL:**

ENGAGEMENT FORCE: 2.5LBS TYPICAL  
 DISENGAGEMENT FORCE: 1.5LBS TYPICAL  
 CONTACT RETENTION: 1.5 LBS MIN AXIAL FORCE  
 DURABILITY: 500 CYCLES MIN

**ENVIRONMENTAL:**

OPERATING TEMPERATURE: -65 TO 165°C  
 THERMAL SHOCK: MIL-STD-202, METHOD 107, CONDITION B  
 MECHANICAL SHOCK: MIL-STD-202, METHOD 213, CONDITION I  
 CORROSION: MIL-STD-202, METHOD 101  
 VIBRATION: MIL-STD-202, METHOD 204  
 MOISTURE RESISTANCE: MIL-STD-202, MEHTOD 106, EXCEPT STEP 7B

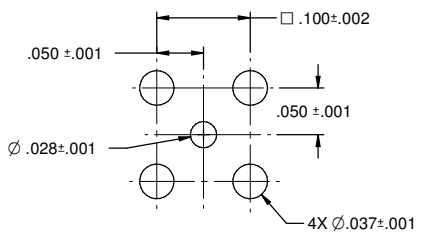

**RECOMMENDED MOUNTING HOLE**  
10:1

THIS DRAWING TO BE INTERPRETED  
PER ANSI Y 14.5M - 1994  
CUSTOMER COPY

TOLERANCE UNLESS OTHERWISE SPECIFIED		DRAWN BY R.SHEN	DATE 1-27-2013
DECIMALS	INCH	CHECKED BY R.SHEN	DATE 1-27-2013
X.X	±0.010	APPROVED BY L.MA	DATE 1-28-2013
X.XX	±0.005	U/M	INCH
X.XXX	±0.003		
ANGLES	±0.5°		

**EMERSON**  
Network Power

**Connectivity Solutions**

TITLE  
SMPM MALE SMOOTH BORE  
STRAIGHT PC MOUNT

SHEET 1 OF 1	DRAWING NO. 125-2701-201	SIZE C
-----------------	-----------------------------	-----------

THIS DRAWING WAS PRODUCED BY COMPUTER,  
DO NOT SCALE DRAWING OR UPDATE MANUALLY.