

ECN/PCN No.: **4479**

For Manufacturer		
Product Description: FULL SIZE DIP METAL CAN CRYSTAL OSCILLATOR	Abracon Part Number / Part Series: EPF11 Series	<input type="checkbox"/> Documentation only <input checked="" type="checkbox"/> Series <input checked="" type="checkbox"/> ECN <input type="checkbox"/> Part Number <input checked="" type="checkbox"/> EOL
Affected Revision: Rev. B 3/25/2014	New Revision: EOL	Application: <input type="checkbox"/> Safety <input checked="" type="checkbox"/> Non-Safety
Prior to Change: ACTIVE		
After Change: EOL		
Cause/Reason for Change: Discontinuation of manufacturing capability		
Change Plan		
Effective Date: 11/15/2022	Additional Remarks: N/A	
Change Declaration: N/A		
Issued Date: 11/15/22	Issued By: <i>Conor Healey</i>	Issued Department: Engineering
Approval: <i>Thomas Culhane</i> Engineering Director	Approval: <i>Reuben Quintanilla</i> Quality Director	Approval: <i>Ying Huang</i> Purchasing Director
For Abracon EOL only		
Last Time Buy (if applicable): 02-15-2023 <small>Based upon material availability, contact Abracon for details</small>	Alternate Part Number / Part Series: ACO	
Additional Approval:	Additional Approval:	Additional Approval:
Customer Approval (If Applicable)		
Qualification Status: <div style="text-align: center;"> <input type="checkbox"/> Approved <input type="checkbox"/> Not accepted </div> <small>Note: It is considered approved if there is no feedback from the customer 1 month after ECN/PCN is released.</small>		
Customer Part Number:	Customer Project:	
Company Name:	Company Representative:	Representative Signature:
Customer Remarks:		

REGULATORY COMPLIANCE

 <p>Lead Free COMPLIANT</p>	 <p>EU RoHS 2011/65 + 2015/863 COMPLIANT</p>	 <p>China RoHS COMPLIANT</p>	 <p>REACH SVHC COMPLIANT</p>	 <p>DRC CONFLICT FREE</p>
--	--	--	--	---

ITEM DESCRIPTION

Quartz Crystal Clock Oscillators XO (SPXO) HCMOS/TTL (CMOS) 5.0Vdc 14 Pin DIP Metal Thru-Hole

ELECTRICAL SPECIFICATIONS

Nominal Frequency	1MHz to 125MHz
Frequency Tolerance/Stability	Inclusive of all conditions: Calibration Tolerance at 25°C, Frequency Stability over the Operating Temperature Range, Supply Voltage Change, Output Load Change, First Year Aging at 25°C, Shock, and Vibration ±100ppm Maximum ±50ppm Maximum
Aging at 25°C	±5ppm/year Maximum
Operating Temperature Range	-20°C to +70°C -40°C to +85°C
Supply Voltage	5.0Vdc ±10%
Input Current	45mA Maximum (Unloaded)
Output Voltage Logic High (V_{OH})	I _{OH} = -16mA V _{dd} -0.4Vdc Minimum (CMOS Output Logic Type) 2.4Vdc Minimum (CMOS Output Logic Type)
Output Voltage Logic Low (V_{OL})	I _{OL} = +16mA 0.4Vdc Maximum
Rise/Fall Time	4nSec Maximum (Measured at 20% to 80% of waveform, CMOS Output Logic Type) 4nSec Maximum (Measured at 0.8Vdc to 2.0Vdc, TTL Output Logic Type)
Duty Cycle	Measured at 1.4Vdc with TTL Load; Measured at 50% of waveform with HCMOS Load 50 ±10(%) 50 ±5(%) (Not available with TTL Output Logic Type over Nominal Frequency range of 27.000001MHz to 125MHz; Not available with CMOS Output Logic Type over Nominal Frequency range of 50.000001MHz to 125MHz)
Load Drive Capability	50pF HCMOS Load Maximum over 1MHz to 50MHz (CMOS Output Logic Type) 15pF HCMOS Load Maximum over 50.000001MHz to 125MHz (CMOS Output Logic Type) 10TTL Load Maximum over 1MHz to 40MHz (TTL Output Logic Type) 5TTL Load Maximum over 40.000001MHz to 125MHz (TTL Output Logic Type)
Output Logic Type	CMOS TTL
Pin 1 Connection	Power Down (Disable Output: Logic Low) Tri-State (Disabled Output: High Impedance)
Pin 1 Input Voltage (V_{IH} and V_{IL})	+2.0Vdc Minimum to enable output, +0.8Vdc to disable output, No Connect to enable output.
Disable Current	30mA Maximum (Pin 1 = Ground, Disabled Output: High Impedance)
Standby Current	50µA Maximum (Pin 1 = Ground, Disable Output: Logic Low)
Peak to Peak Jitter (t_{PK})	500pSec Maximum, 90pSec Typical over Nominal Frequency of 1MHz to 11.999999MHz 100pSec Maximum, 50pSec Typical over Nominal Frequency of 12MHz to 125MHz
RMS Period Jitter (t_{RMS})	50pSec Maximum, 13pSec Typical over Nominal Frequency of 1MHz to 11.999999MHz 13pSec Maximum, 8pSec Typical over Nominal Frequency of 12MHz to 125MHz
Start Up Time	10mSec Maximum
Storage Temperature Range	-55°C to +125°C

PART NUMBERING GUIDE

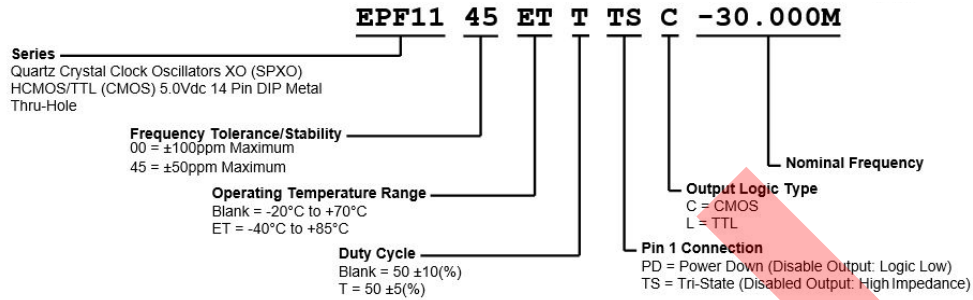

MECHANICAL DIMENSIONS

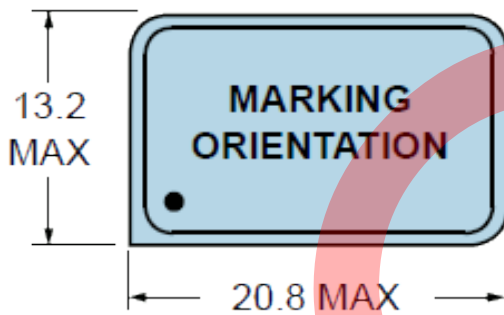
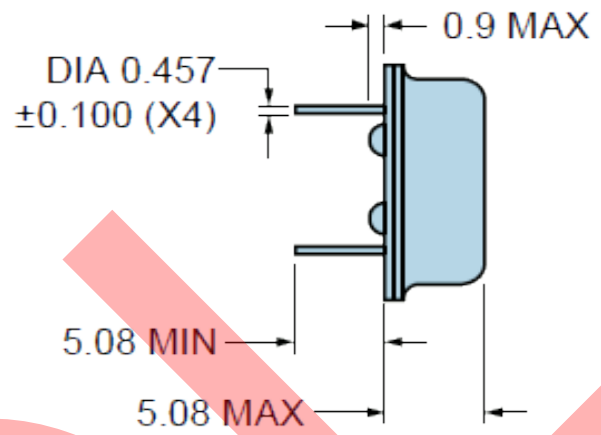
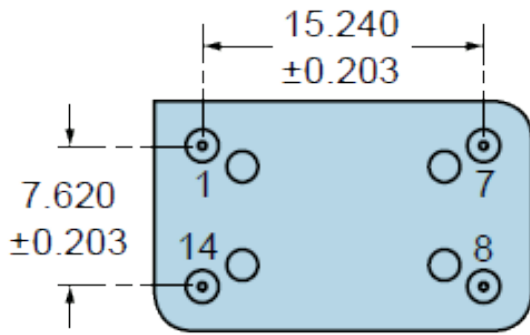

PIN	CONNECTION
1	Power Down Or Tri-State
7	Ground/Case Ground
8	Output
14	Supply Voltage

All Dimensions in Millimeters

OUTPUT WAVEFORM & TIMING DIAGRAM

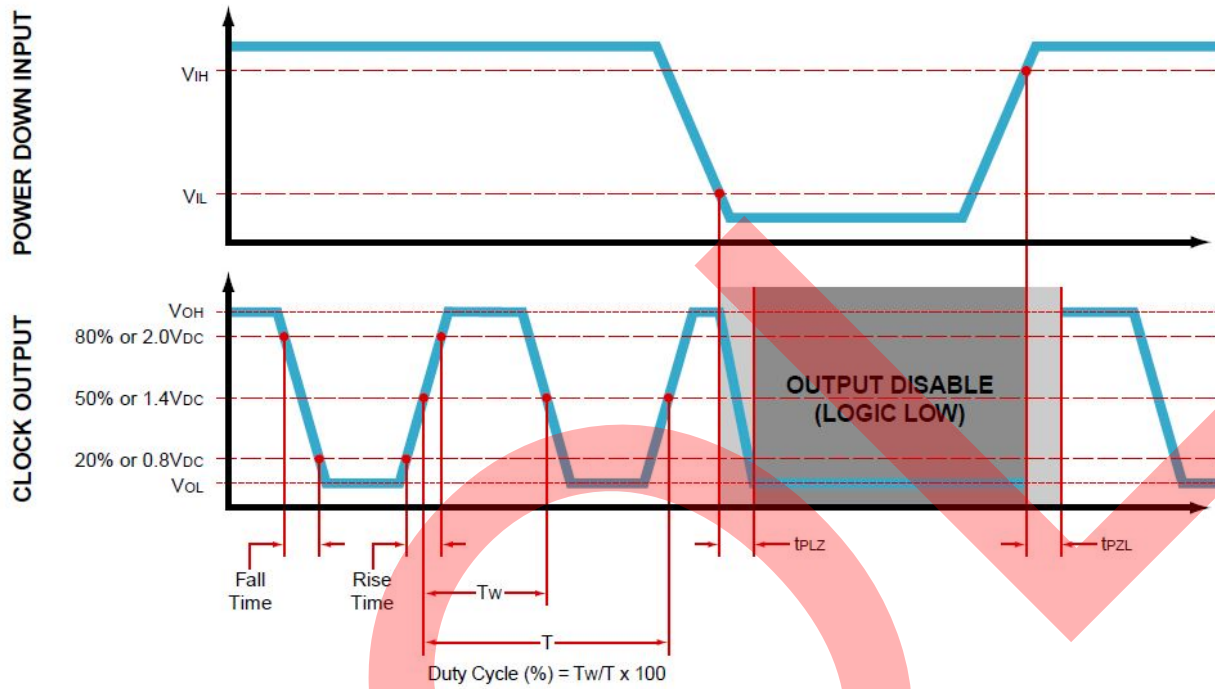

TEST CIRCUIT FOR CMOS OUTPUT

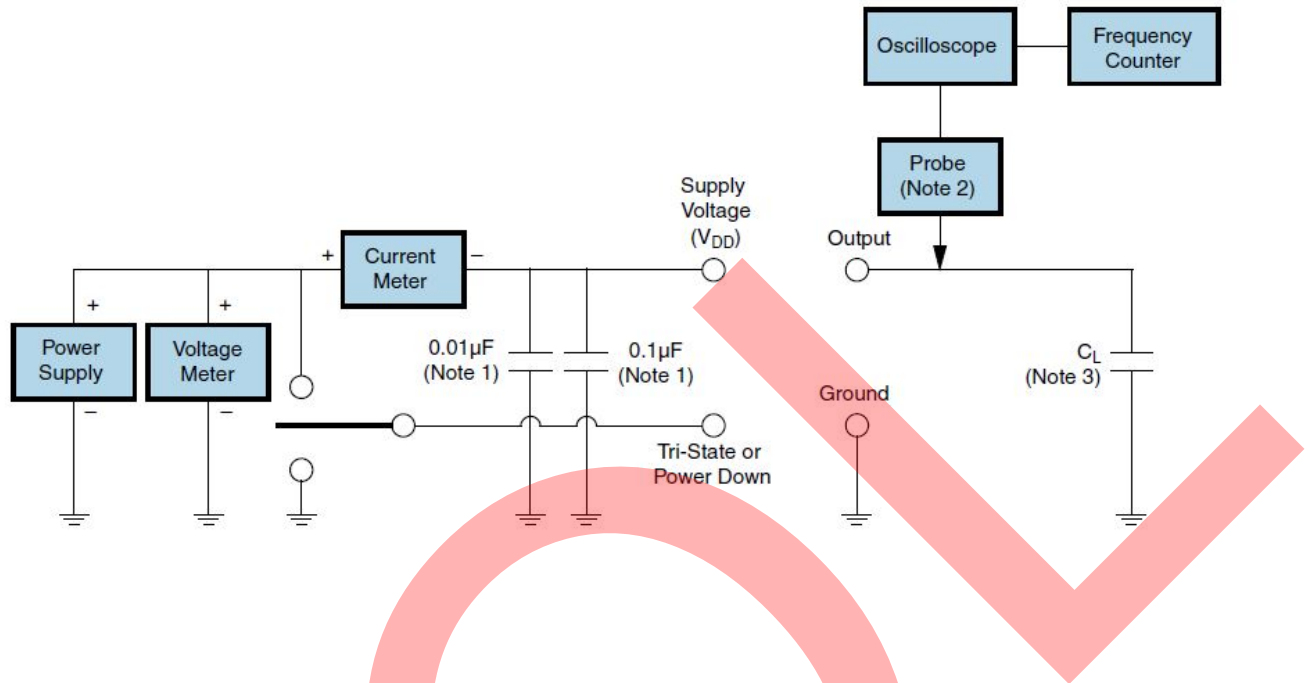

- Note 1:** An external 0.01µF Ceramic bypass capacitor in parallel with a 0.1µF high frequency ceramic bypass Capacitor close (less Than 2mm) to the package ground and supply voltage pin is required.
- Note 2:** A low input capacitance (<12pF), 10X Attenuation factor, High impedance (>10Mohms), and High bandwidth (>300MHz) Passive probe is recommended.
- Note 3:** Capacitance value C_L includes sum of all probe and fixture capacitance. See applicable specification sheet for 'Load Drive Capability'.

RECOMMENDED SOLDER REFLOW METHOD

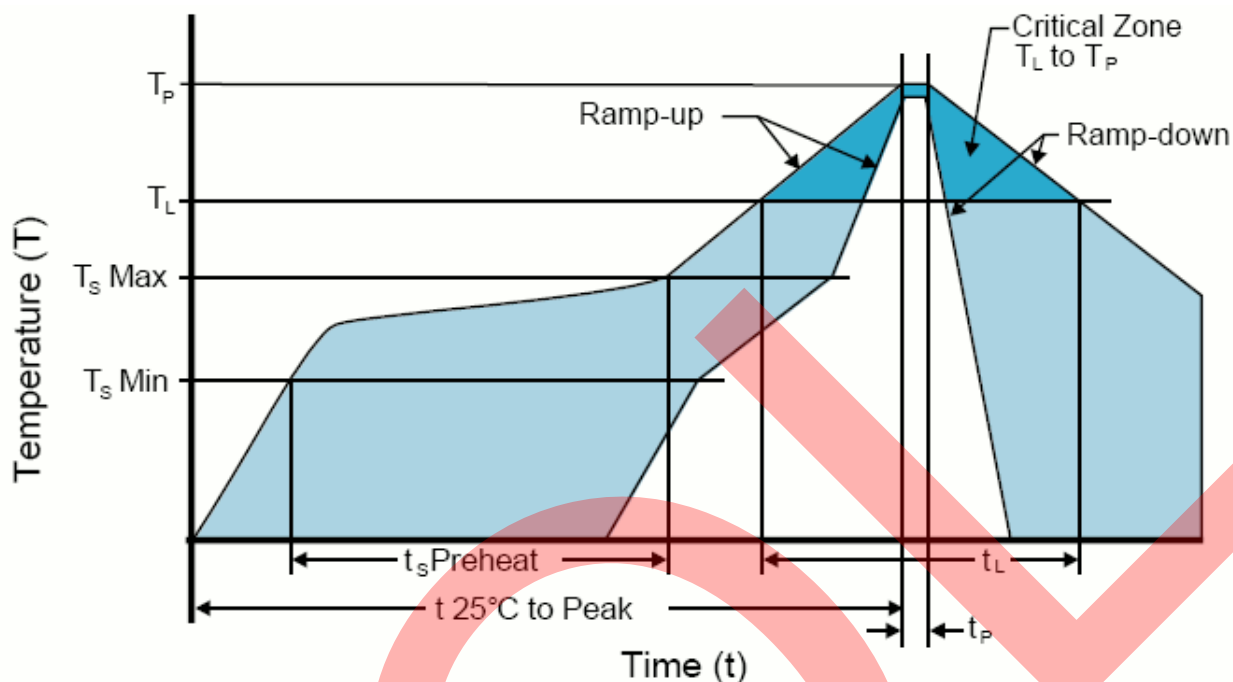

HIGH TEMPERATURE SOLDER BATH (WAVE SOLDER)

T_S MAX to T_L (Ramp-up Rate)	3°C/Second Maximum
Preheat	
- Temperature Minimum (T _S MIN)	150°C
- Temperature Typical (T _S TYP)	175°C
- Temperature Maximum (T _S MAX)	200°C
- Time (t _s MIN)	60 - 180 Seconds
Ramp-up Rate (T_L to T_P)	3°C/Second Maximum
Time Maintained Above:	
- Temperature (T _L)	217°C
- Time (t _L)	60 - 150 Seconds
Peak Temperature (T_P)	260°C Maximum for 10 Seconds Maximum
Target Peak Temperature (T_P Target)	250°C +0/-5°C
Time within 5°C of actual peak (t_p)	20 - 40 Seconds
Ramp-down Rate	6°C/Second Maximum
Time 25°C to Peak Temperature (t)	8 Minutes Maximum
Moisture Sensitivity Level	Level 1
Additional Notes	Temperatures shown are applied to back of PCB board and device leads only. Do not use this method for Product with the Gull Wing option.

High Temperature Manual Soldering

260°C Maximum for 5 Seconds Maximum, 2 times Maximum. (Temperatures shown are applied to device leads only. This method can be utilized with both Gull Wing and Non-Gull Wing devices.)

RECOMMENDED SOLDER REFLOW METHOD

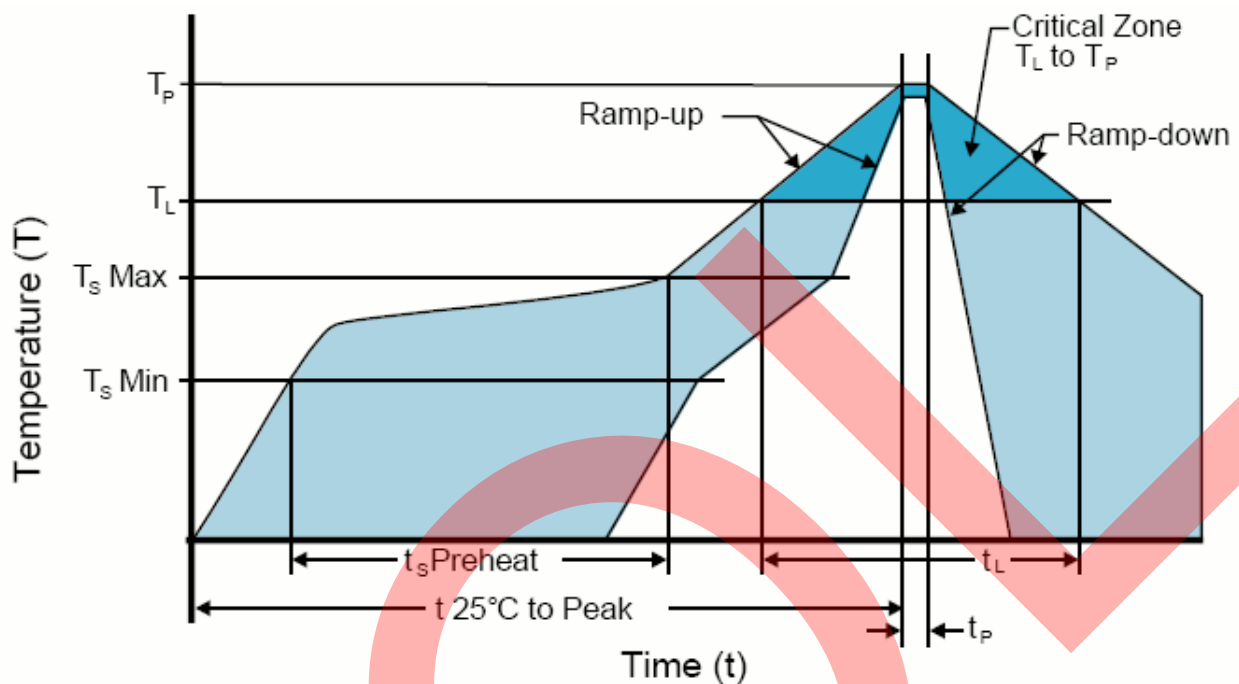

LOW TEMPERATURE SOLDER BATH (WAVE SOLDER)

T_S MAX to T_L (Ramp-up Rate)	5°C/Second Maximum
Preheat	
- Temperature Minimum (T _S MIN)	N/A
- Temperature Typical (T _S TYP)	150°C
- Temperature Maximum (T _S MAX)	N/A
- Time (t _s MIN)	30 - 60 Seconds
Ramp-up Rate (T_L to T_P)	5°C/Second Maximum
Time Maintained Above:	
- Temperature (T _L)	150°C
- Time (t _L)	200 Seconds Maximum
Peak Temperature (T_P)	245°C Maximum
Target Peak Temperature (T_P Target)	245°C Maximum 1 Time / 235°C Maximum 2 Times
Time within 5°C of actual peak (t_P)	5 Seconds Maximum 1 Time / 15 Seconds Maximum 2 Times
Ramp-down Rate	5°C/Second Maximum
Time 25°C to Peak Temperature (t)	N/A
Moisture Sensitivity Level	Level 1
Additional Notes	Temperatures shown are applied to back of PCB board and device leads only. Do not use this method for Product with the Gull Wing Option.

Low Temperature Manual Soldering

185°C Maximum for 10 Seconds Maximum, 2 times Maximum. (Temperatures shown are applied to device leads only. This method can be utilized with both Gull Wing and Non-Gull Wing devices.)

RECOMMENDED SOLDER REFLOW METHOD

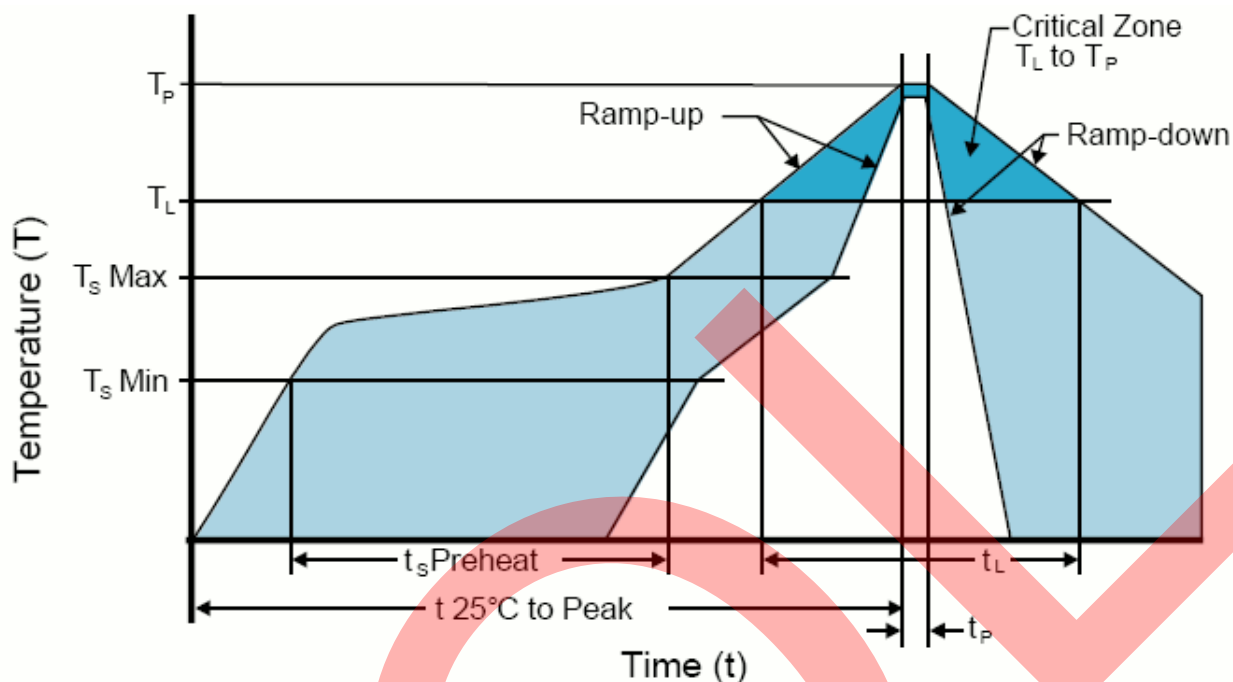

LOW TEMPERATURE INFRARED/CONVECTION

T_S MAX to T_L (Ramp-up Rate)	5°C/Second Maximum
Preheat	
- Temperature Minimum (T _S MIN)	N/A
- Temperature Typical (T _S TYP)	150°C
- Temperature Maximum(T _S MAX)	N/A
- Time (t _S MIN)	60 - 120 Seconds
Ramp-up Rate (T_L to T_P)	5°C/Second Maximum
Time Maintained Above:	
- Temperature (T _L)	150°C
- Time (t _L)	200 Seconds Maximum
Peak Temperature (T_P)	185°C Maximum
Target Peak Temperature(T_P Target)	185°C Maximum 2 Times
Time within 5°C of actual peak (t_p)	10 Seconds Maximum 2 Times
Ramp-down Rate	5°C/Second Maximum
Time 25°C to Peak Temperature (t)	N/A
Moisture Sensitivity Level	Level 1
Additional Notes	Temperatures shown are applied to body of device. Use this method only for product with the Gull Wing Option.