

## DX25 Series: 25 GHz Photodetectors

### FEATURES

- DC – 25 GHz Bandwidth
- 19 ps Impulse Response
- 700 nm – 870 nm Sensitivity
- SM or MM Input Fiber Options
- 2.92 mm Coaxial Output Connector
- 50  $\Omega$  Reverse Termination

### APPLICATIONS

- Test and Measurement
- High-Speed Communications
- Microwave Photonics
- OEM Integration



DX25CF

### DESCRIPTION

The DX25 Series are hermetically sealed detector modules with a 12 GHz bandwidth that use a GaAs-based photodetector for applications primarily in the 700 nm – 870 nm wavelength range. The module can be supplied with either SM (SMF-28) or MM ( $\text{\O}50 \mu\text{m}$  core, OM4) fiber optic input. Signal output is provided via a field-replaceable, female, 2.92 mm RF connector, which may be connected to a measurement instrument with suitable adapters or cables. Order by the following model numbers:

- **DX25CF** DX25 Series Module with SM Fiber (SMF-28), Yellow Buffer, and FC/PC Connector
- **DX25DF** DX25 Series Module with  $\text{\O}50 \mu\text{m}$  Core MM Fiber (OM4), Aqua Buffer, and FC/PC Connector

### BLOCK DIAGRAM

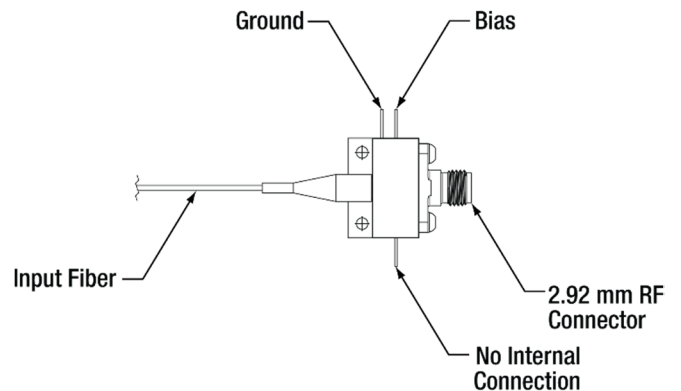
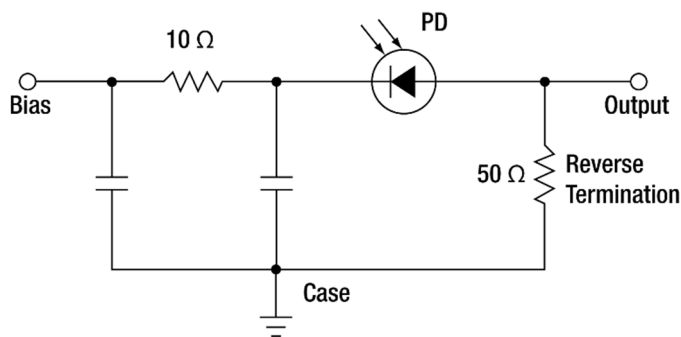

## ABSOLUTE MAXIMUM RATINGS

All specifications are at 25 °C and at 850 nm unless noted.

Parameter	Min	Typical	Max	Unit	Note
Optical Input Power, Average	-	-	10	dBm	-
Optical Input Power, Peak	-	-	13	dBm	50% Duty Cycle
Photodiode Bias Voltage	-	-	5	V	-
Fiber Bend Radius	15	-	-	mm	Breakage

## OPERATING CONDITIONS

Parameter	Min	Typical	Max	Unit	Note
Operating Temperature	0	-	70	°C	-
Storage Temperature	-40	-	75	°C	-
Relative Humidity	-	-	85	%	Non-Condensing
Photodiode Bias Voltage	3	4	5	V	-

## SPECIFICATIONS

All specifications are at 25 °C and at 850 nm unless noted.

Parameter	Fiber Type <sup>a</sup>	Min	Typical	Max	Unit	Note
Wavelength Range		700	-	870	nm	See Performance Graphs for Full Spectral Response
-3 dB Bandwidth		-	25	-	GHz	At 780 nm
Low Frequency Cutoff		-	DC	-	-	-
Impulse Response		-	19	-	ps	FWHM at 780 nm
Responsivity	SM MM	-	0.5 0.45	-	A/W	-
Conversion Gain	SM MM	-	12.5 11.0	-	V/W	Across External 50 Ω Load
Noise-Equivalent Power		-	51	-	pW/√Hz	25 Ω Load Limited
Optical Return Loss	SM MM	-	-	-25 -18	dB	-
Dark Current		-	-	50	nA	-
Reverse Termination Impedance		45	50	55	Ω	RF Output
Electrical Return Loss		-	-10	-	dB	To 25 GHz

a. Specifications are dependent on the fiber type chosen. See the Description section on page 1 for ordering information for SM and MM item #s.

## QUALIFICATION TESTING

Parameter	Conditions
Mechanical Shock	500g, Six Axes, 5 Times
Thermal Cycling	100 Cycles, 0 °C to 70 °C
Temperature Storage	100 hours at -40 °C
Fiber Pull	Straight Pull: 0.5 kg, 60 s Side Pull: 0.25 kg, 10 s, 4 Directions

# MECHANICAL & PIN-OUT

Parameter	Value
Fiber Connector	2.0 mm Narrow Key FC/PC
Fiber Type	SMF-28 (Item # DX25CF) or Ø50 µm Core, OM4 (Item # DX25DF)
Fiber Length	90 cm ± 10 cm
Fiber Buffer	Ø900 µm, Yellow for SM, Aqua for MM
RF Output Connector	Female 2.92 mm, 50 Ω, Field Replaceable
Lead Soldering	Max 10 s at 250 °C per Lead

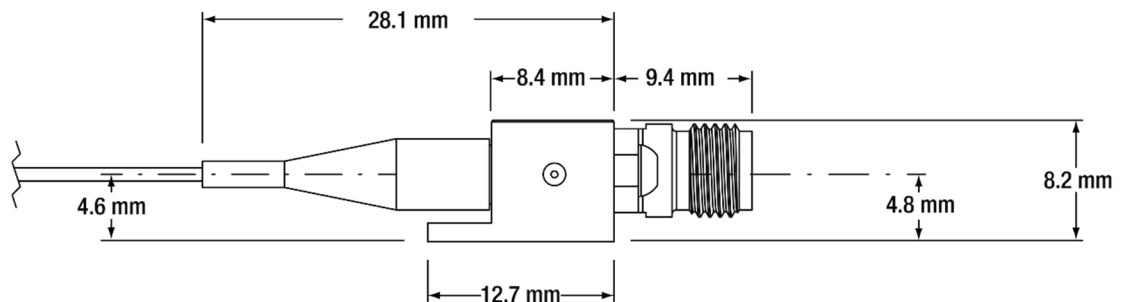
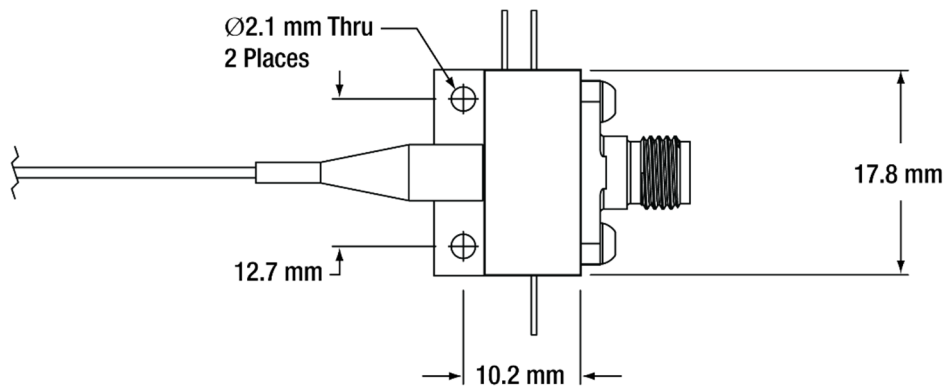
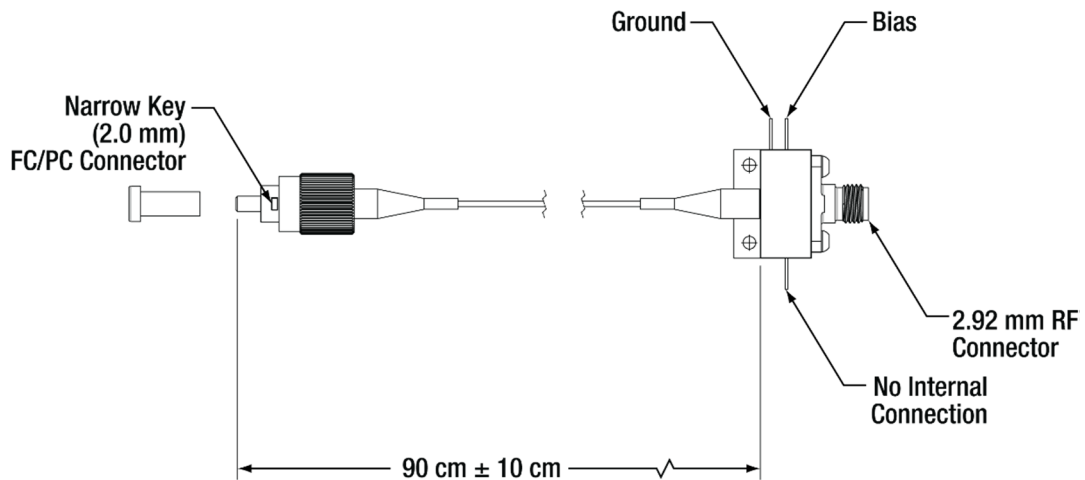

## TYPICAL PERFORMANCE GRAPHS

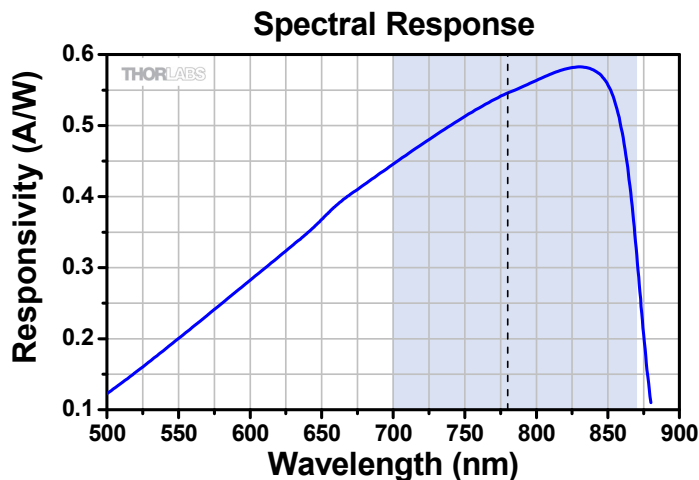

Vertical dashed line indicates the wavelength that the frequency and impulse responses are measured. The blue-shaded region indicates the wavelength range.

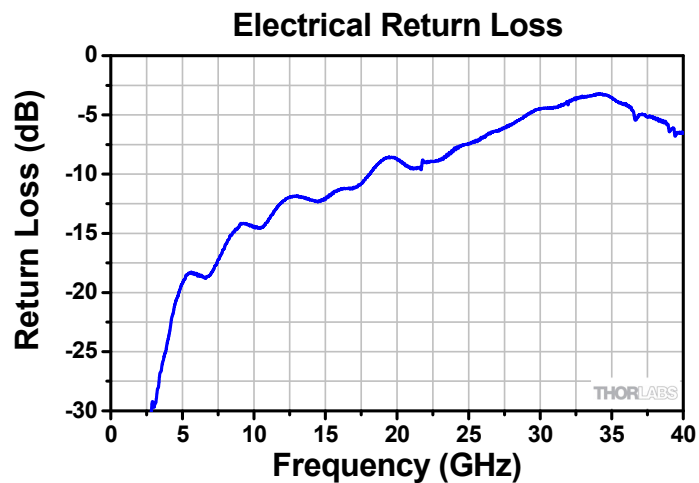
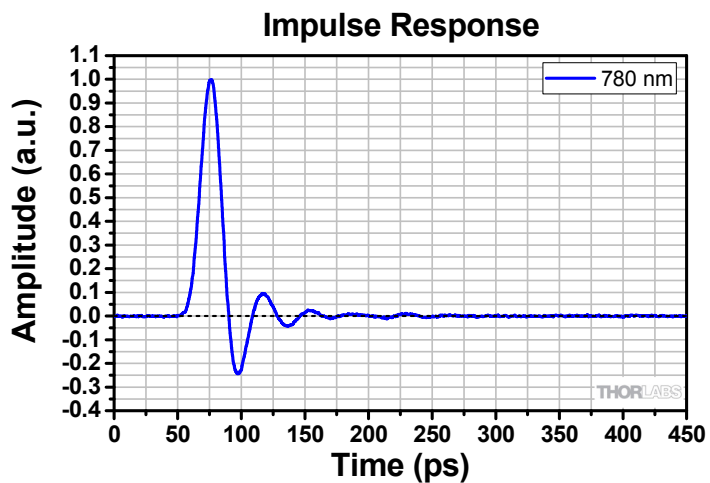
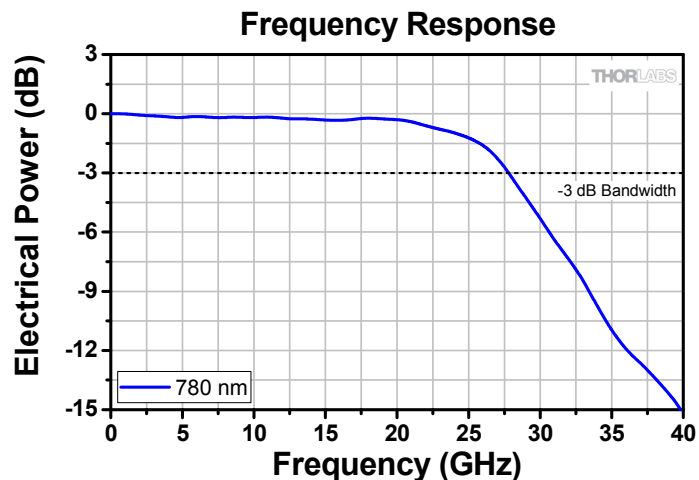

## PRECAUTIONS



The components inside this module are ESD sensitive. Take all appropriate precautions to discharge personnel and equipment before making any electrical connections to the unit. This also applies to coaxial cables that easily accumulate capacitive charge.

## MANUFACTURING AND COMPLIANCE

Manufactured by: Thorlabs Inc., Ann Arbor, MI 48103 USA

