

AM9513A

System Timing Controller

The AM9513A System Timing Controller is an LSI circuit designed to service many types of counting, sequencing and timing applications. It provides the capability for programmable frequency synthesis, high resolution programmable duty cycle waveforms, retriggerable digital one-shots, time-of-day clocking, coincidence alarms, complex pulse generation, high resolution baud rate generation, frequency shift keying, stop-watching timing, event count accumulation, waveform analysis, etc. A variety of programmable operating modes and control features allows the AM9513A to be personalized for particular applications as well as dynamically reconfigured under program control.

Rochester Electronics Manufactured Components

Rochester branded components are manufactured using either die/wafers purchased from the original suppliers or Rochester wafers recreated from the original IP. All recreations are done with the approval of the OCM.

Parts are tested using original factory test programs or Rochester developed test solutions to guarantee product meets or exceeds the OCM data sheet.

Quality Overview

- ISO-9001
- AS9120 certification
- Qualified Manufacturers List (QML) MIL-PRF-38535
 - Class Q Military
 - Class V Space Level
- Qualified Suppliers List of Distributors (QSLD)
 - Rochester is a critical supplier to DLA and meets all industry and DLA standards.

Rochester Electronics, LLC is committed to supplying products that satisfy customer expectations for quality and are equal to those originally supplied by industry manufacturers.

The original manufacturer's datasheet accompanying this document reflects the performance and specifications of the Rochester manufactured version of this device. Rochester Electronics guarantees the performance of its semiconductor products to the original OEM specifications. 'Typical' values are for reference purposes only. Certain minimum or maximum ratings may be based on product characterization, design, simulation, or sample testing.

CONNECTION DIAGRAMS Top View

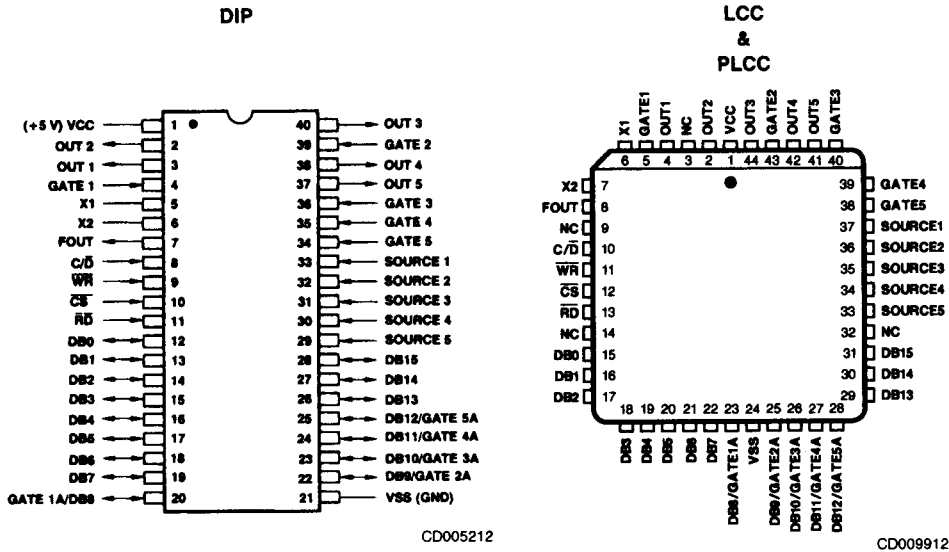

Note: Pin 1 is marked for orientation.

ORDERING INFORMATION Standard Products

AMD standard products are available in several packages and operating ranges. The order number (Valid Combination) is formed by a combination of:

- a. **Device Number**
- b. **Speed Option** (if applicable)
- c. **Package Type**
- d. **Temperature Range**
- e. **Optional Processing**

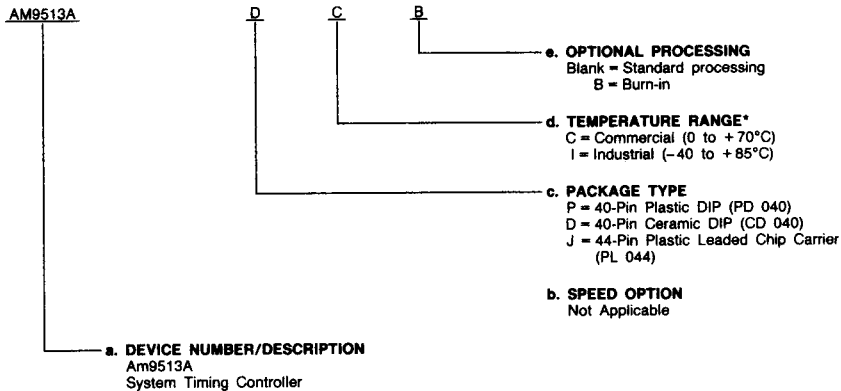

Valid Combinations

AM9513A	PC, DC, DCB, DIB, JC
---------	----------------------

*This device is also available in Military temperature range.

Valid Combinations

Valid Combinations list configurations planned to be supported in volume for this device. Consult the local AMD sales office to confirm availability of specific valid combinations, to check on newly released combinations, and to obtain additional data on AMD's standard military grade products.

ORDERING INFORMATION (continued)

Standard Military Drawing (SMD)/DESC Products

AMD products for Aerospace and Defense applications are available in several packages and operating ranges. Standard Military Drawing (SMD)/DESC products are fully compliant with MIL-STD-883C requirements. The order number (Valid Combination) for SMD/DESC products is formed by a combination of:

- a. **Military Drawing Part Number**
- b. **Device Type**
- c. **Case Outline**
- d. **Lead Finish**

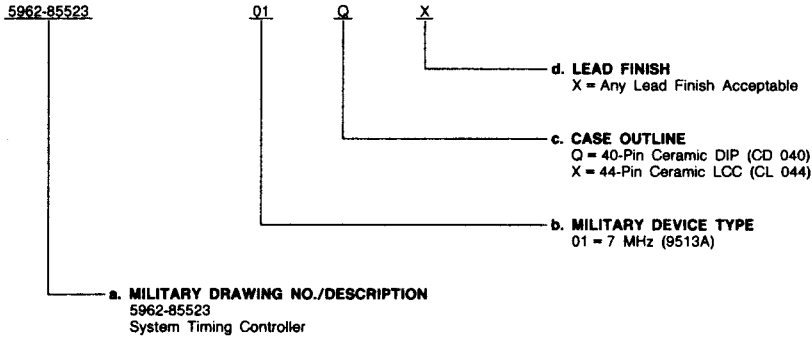

Valid Combinations

Valid Combinations list configurations planned to be supported in volume for this device. Consult the local AMD sales office to confirm availability of specific valid combinations or to check for newly released valid combinations.

Valid Combinations	
5962-8552301	QX, XX

Group A Tests

Group A tests consist of Subgroups
1, 2, 3, 7, 8, 9, 10, 11.

ORDERING INFORMATION (continued)

APL Products

AMD products for Aerospace and Defense applications are available in several packages and operating ranges. APL (Approved Products List) products are fully compliant with MIL-STD-883C requirements. The order number (Valid Combination) for APL products is formed by a combination of:

- a. **Device Number**
- b. **Speed Option** (if applicable)
- c. **Device Class**
- d. **Package Type**
- e. **Lead Finish**

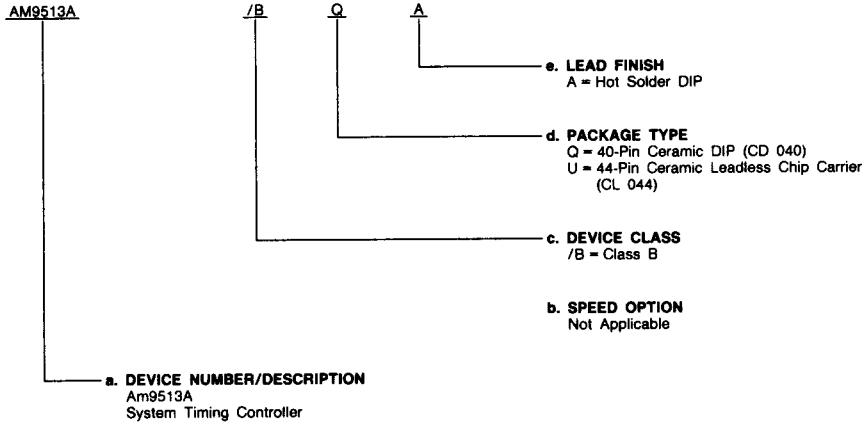

Valid Combinations	
AM9513A	/BQA, /BUA

Valid Combinations

Valid Combinations list configurations planned to be supported in volume for this device. Consult the local AMD sales office to confirm availability of specific valid combinations or to check for newly released valid combinations.

Group A Tests

Group A tests consist of
Subgroups 1, 2, 3, 7, 8, 9, 10, 11.

PIN DESCRIPTION

Pin No.	Name	I/O	Description
1	VCC		+5 V Power Supply.
21	VSS		Ground.
5, 6	X1, X2	O, I	(Crystal). X1 and X2 are the connections for an external crystal used to determine the frequency of the internal oscillator. The crystal should be a parallel-resonant, fundamental-mode type. An RC or LC or other reactive network may be used instead of a crystal. For driving from an external frequency source, X1 should be left open and X2 should be connected to a TTL source and a pull-up resistor.
7	FOUT	O	(Frequency Out). The FOUT output is derived from a 4-bit counter that may be programmed to divide its input by any integer value from 1 through 16 inclusive. The input to the counter is selected from any of 15 sources, including the internal scaled oscillator frequencies. FOUT may be gated on and off under software control and when off will exhibit a low impedance to ground. Control over the various FOUT options resides in the Master Mode register. After power-up, FOUT provides a frequency that is 1/16 that of the oscillator. The input source on power-up is F1.
4, 39, 36 - 34	GATE1 - GATE5	I	(Gate). The Gate inputs may be used to control the operations of individual counters by determining when counting may proceed. The same Gate input may control up to three counters. Gate pins may also be selected as count sources for any of the counters and for the FOUT divider. The active polarity for a selected Gate input is programmed at each counter. Gating function options allow level-sensitive gating or edge-initiated gating. Other gating modes are available including one that allows the Gate input to select between two counter output frequencies. All gating functions may also be disabled. The active Gate input is conditioned by an auxiliary input when the unit is operating with an external 8-bit data bus. See Data Bus description. Schmitt-trigger circuitry on the GATE inputs allows slow transition times to be used.
33 - 29	SRC1 - SRC5	I	(Source). The Source inputs provide external signals that may be counted by any of the counters. Any Source line may be routed to any or all of the counters and the FOUT divider. The active polarity for a selected SRC input is programmed at each counter. Any duty cycle waveform will be accepted as long as the minimum pulse width is at least half the period of the maximum specified counting frequency for the part. Schmitt-trigger circuitry on the SRC inputs allows slow transition times to be used.
3, 2, 40, 38, 37	OUT1 - OUT5	O	(Counter). Each 3-state OUT signal is directly associated with a corresponding individual counter. Depending on the counter configuration, the OUT signal may be a pulse, a square wave, or a complex duty cycle waveform. OUT pulse polarities are individually programmable. The output circuitry detects the counter state that would have been all bits zero in the absence of a reinitialization. That information is used to generate the selected waveform type. An optional output mode for Counters 1 and 2 overrides the normal output mode and provides a true OUT signal when the counter contents match the contents of an Alarm register.
12 - 19, 20, 22 - 28	DB0 - DB7, DB8 - DB15	I/O	(Data Bus). The 16 bidirectional Data Bus lines are used for information exchanges with the host processor. HIGH on a Data Bus line corresponds to one and LOW corresponds to zero. These lines act as inputs when \overline{WR} and \overline{CS} are active and as outputs when \overline{RD} and \overline{CS} are active. When \overline{CS} is inactive, these pins are placed in a high-impedance state. After power-up or reset, the data bus will be configured for 8-bit width and will use only DB0 through DB7. DB0 is the least significant and DB7 is the most significant bit position. The data bus may be reconfigured for 16-bit width by changing a control bit in the Master Mode register. This is accomplished by writing an 8-bit command into the low-order DB lines while holding the DB13 - DB15 lines at a logic high level. Thereafter, all 16 lines can be used, with DB0 as the least significant and DB15 as the most significant bit position. When operating in the 8-bit data bus environment, DB8 - DB15 will never be driven active by the Am9513A. DB8 through DB12 may optionally be used as additional Gate inputs (see Figure 2). If unused, they should be held HIGH. When pulled LOW, a GATENA signal will disable the action of the corresponding counter N gating. DB13 - DB15 should be held HIGH in 8-bit bus mode whenever \overline{CS} and \overline{WR} are simultaneously active.
10	\overline{CS}	I	(Chip Select). The active-low Chip Select input enables Read and Write operations on the data bus. When Chip Select is HIGH, the Read and Write inputs are ignored. The first Chip Select signal after power-up is used to clear the power-on reset circuitry. If Chip Select is tied to ground permanently, the power-on reset circuitry may not function. In such a configuration, the software reset command must be issued following power-up to reset the Am9513A.
11	\overline{RD}	I	(Read). The active-low Read signal is conditioned by Chip Select and indicates that internal information is to be transferred to the data bus. The source will be determined by the port being addressed and, for Data Port reads, by the contents of the Data Pointer register. \overline{WR} and \overline{RD} should be mutually exclusive.
9	\overline{WR}	I	(Write). The active-low Write signal is conditioned by Chip Select and indicates that data bus information is to be transferred to an internal location. The destination will be determined by the port being addressed and, for Data Port writes, by the contents of the Data Pointer register. \overline{WR} and \overline{RD} should be mutually exclusive.
8	C/D	I	(Control/Data). The Control/Data signal selects source and destination locations for Read and Write operations on the data bus. Control Write operations load the Command register and the Data Pointer. Control Read operations output the Status register. Data Read and Data Write transfers communicate with all other internal registers. Indirect addressing at the data port is controlled internally by the Data Pointer register.

Signal	Abbreviation	Type	Pins
+ 5 Volts	VCC	Power	1
Ground	VSS	Power	1
Crystal	X1, X2	O, I	2
Read	\overline{RD}	Input	1
Write	\overline{WR}	Input	1
Chip Select	\overline{CS}	Input	1
Control/Data	C/ \overline{D}	Input	1
Source N	SRC	Input	5
Gate N	GATE	Input	5
Data Bus	DB	I/O	16
Frequency Out	FOUT	Output	1
Out N	OUT	Output	5

Figure 1. Interface Signal Summary

Figure 1 summarizes the interface signals and their abbreviations for the STC.

Package Pin	Data Bus Width (MM14)	
	16 Bits	8 Bits
12	DB0	DB0
13	DB1	DB1
14	DB2	DB2
15	DB3	DB3
16	DB4	DB4
17	DB5	DB5
18	DB6	DB6
19	DB7	DB7
20	DB8	GATE 1A
22	DB9	GATE 2A
23	DB10	GATE 3A
24	DB11	GATE 4A
25	DB12	GATE 5A
26	DB13	(VIH)
27	DB14	(VIH)
28	DB15	(VIH)

Figure 2. Data Bus Assignments

Interface Considerations

All of the input and output signals for the Am9513A are specified with logic levels compatible with those of standard TTL circuits. In addition to providing TTL compatible voltage levels, other output conditions are specified to help configure non-standard interface circuitry. The logic level specifications take into account all worst-case combinations of the three variables that affect the logic level thresholds: ambient temperature, supply voltage and processing parameters. A change in any of these toward nominal values will improve the actual operating margins and will increase noise immunity.

Unprotected open gate inputs of high quality MOS transistors exhibit very high resistances on the order of perhaps 10^{14} ohms. It is easy, therefore, in some circumstances, for charge to enter the gate node of such an input faster than it can be discharged and consequently, for the gate voltage to rise high enough to break down the oxides and destroy the transistor.

All inputs to the Am9513A include protection networks to help prevent damaging accumulations of static charge. The protection circuitry is designed to slow the transitions of incoming current surges and to provide low-impedance discharge paths for voltages beyond the normal operating levels. Note, however, that input energy levels can nonetheless be too high to be successfully absorbed. Conventional design, storage, and handling precautions should be observed so that the protection networks themselves are not overstressed.

Within the limits of normal operation, the input protection circuitry is inactive and may be modeled as a lumped series RC as shown in Figure 3(a). The functionally active input connection during normal operation is the gate of a MOS transistor. No active sources or drains are connected to the inputs so that neither transient nor steady-state currents are impressed on the driving signals other than the charging or discharging of the input capacitance and the accumulated leakage associated with the protection network and the input circuit.

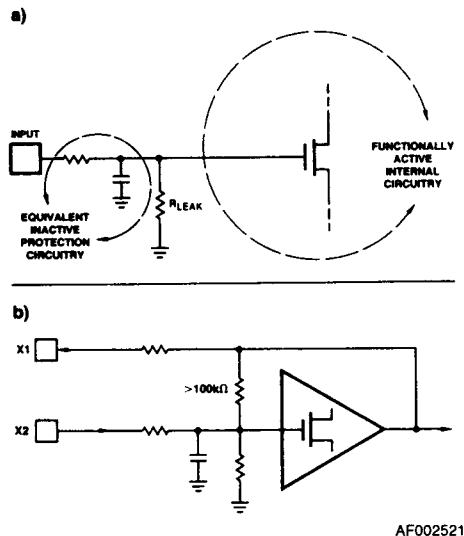

AF002521

Figure 3. Input Circuitry

The only exception to the purely capacitive input case is the X2 crystal input. As shown in Figure 3(b) an internal resistor connects X1 and X2 in addition to the protection network. The resistor is a modestly high value of more than 100kohms.

Fanout from the driving circuitry into the Am9513A inputs will generally be limited by transition time considerations rather than DC current limitations when the loading is dominated by conventional MOS circuits. In an operating environment, all inputs should be terminated so they do not float and therefore will not accumulate stray static charges. Unused inputs should be tied directly to Ground or VCC, as appropriate. An input in use will have some type of logic output driving it, and termination during operation will not be a problem. Where inputs are driven from logic external to the card containing this chip, however, on-board termination should be provided to protect the chip when the board is unplugged (the input would otherwise float). A pull-up resistor or a simple inverter or gate will suffice.

DETAILED DESCRIPTION

The Am9513A System Timing Controller (STC) is a support device for processor oriented systems that is designed to enhance the available capability with respect to counting and timing operations. It provides the capability for programmable frequency synthesis, high resolution programmable duty cycle waveforms, retriggerable digital timing functions, time-of-day clocking, coincidence alarms, complex pulse generation, high resolution baud rate generation, frequency shift keying, stop-watching timing, event count accumulation, waveform analysis and many more. A variety of programmable operating modes and control features allow the Am9513A to be personalized for particular applications as well as dynamically reconfigured under program control.

The STC includes five general-purpose 16-bit counters. A variety of internal frequency sources and external pins may be selected as inputs for individual counters with software selectable active-high or active-low input polarity. Both hardware and software gating of each counter is available. Three-state outputs for each counter provide either pulses or levels. The counters can be programmed to count up or down in either binary or BCD. The accumulated count may be read without disturbing the counting process. Any of the counters may be internally concatenated to form an effective counter length of up to 80 bits.

The Am9513A block diagrams indicate the interface signals and the basic flow of information. Internal control lines and the internal data bus have been omitted. The control and data registers are all connected to a common internal 16-bit bus. The external bus may be 8- or 16-bits wide; in the 8-bit mode, the internal 16-bit information is multiplexed to the low order data bus pins DB0 through DB7.

An internal oscillator provides a convenient source of frequencies for use as counter inputs. The oscillator's frequency is controlled at the X1 and X2 interface pins by an external reactive network such as a crystal. The oscillator output is divided by the Frequency Scaler to provide several sub-frequencies. One of the scaled frequencies (or one of ten input signals) may be selected as an input to the FOUT divider and then comes out of the chip at the FOUT interface pin.

The STC is addressed by the external system as two locations: a Control port and a Data port. The Control port

provides direct access to the Status and Command registers, as well as allowing the user to update the Data Pointer register. The Data port is used to communicate with all other addressable internal locations. The Data Pointer register controls the Data port addressing.

Among the registers accessible through the Data port are the Master Mode register and five Counter Mode registers, one for each counter. The Master Mode register controls the programmable options that are not controlled by the Counter Mode registers.

Each of the five general-purpose counters is 16-bits long and is independently controlled by its Counter Mode register. Through this register, a user can software select one of 16 sources as the counter input, a variety of gating and repetition modes, up or down counting in binary or BCD and active-high or active-low input and output polarities.

Associated with each counter are a Load register and a Hold register, both accessible through the Data port. The Load register is used to automatically reload the counter to any predefined value, thus controlling the effective count period. The Hold register is used to save count values without disturbing the count process, permitting the host processor to read intermediate counts. In addition, the Hold register may be used as a second Load register to generate a number of complex output waveforms.

All five counters have the same basic control logic and control registers. Counters 1 and 2 have additional Alarm registers and comparators associated with them, plus the extra logic necessary for operating in a 24-hour time-of-day mode. For real-time operation, the time-of-day logic will accept 50Hz, 60Hz or 100Hz input frequencies.

Each general counter has a single dedicated output pin. It may be turned off when the output is not of interest or may be configured in a variety of ways to drive interrupt controllers, Darlington buffers, bus drivers, etc. The counter inputs, on the other hand, are specifically not dedicated to any given interface line. Considerable versatility is available for configuring both the input and the gating of individual counters. This not only permits dynamic reassignment of inputs under software control, but also allows multiple counters to use a single input and a single gate pin to control more than one counter. Indeed, a single pin can be the gate for one counter and, at the same time, the count source for another.

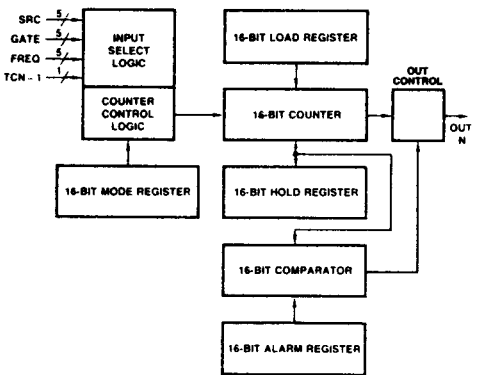

LS001221

Figure 4. Counter Logic Groups 1 and 2

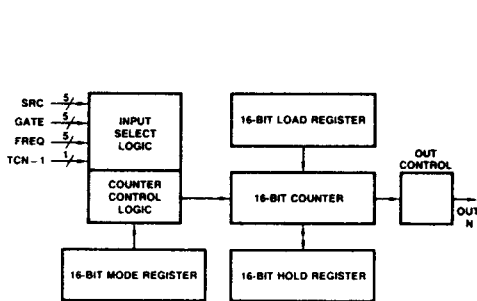

LS001231

Figure 5. Counter Logic Groups 3, 4 and 5

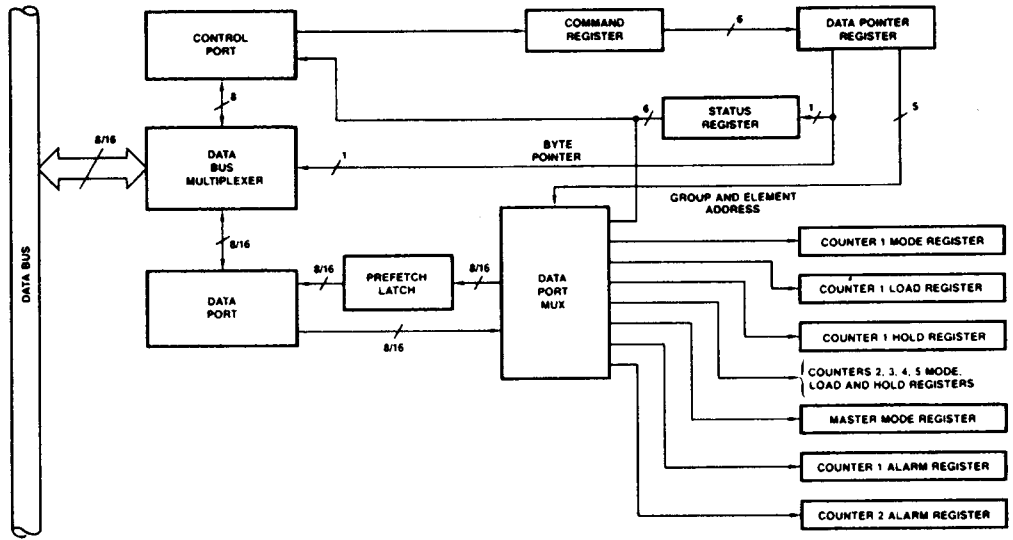

AF002531

Figure 6. Am9513A Register Access

2

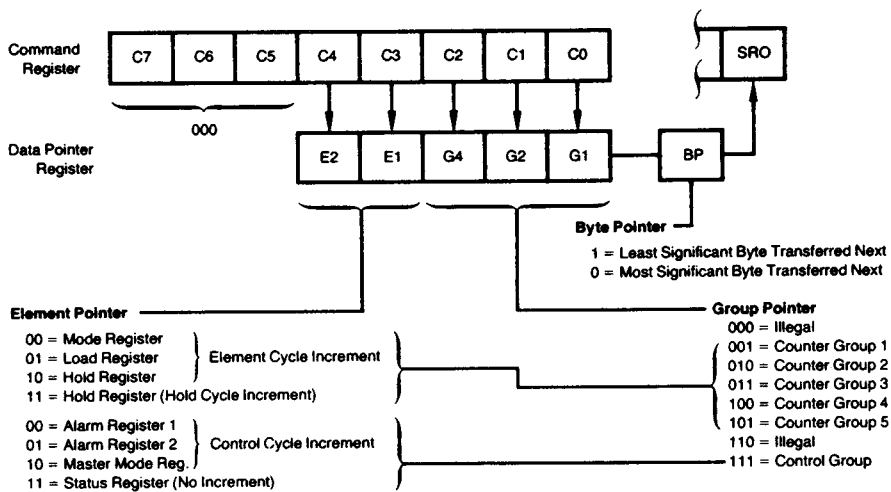

DF001890

Figure 7. Data Pointer Register

	Element Cycle			Hold Cycle
	Mode Register	Load Register	Hold Register	Hold Register
Counter 1	FF01	FF09	FF11	FF19
Counter 2	FF02	FF0A	FF12	FF1A
Counter 3	FF03	FF0B	FF13	FF1B
Counter 4	FF04	FF0C	FF14	FF1C
Counter 5	FF05	FF0D	FF15	FF1D

Master Mode Register = FF17
 Alarm 1 Register = FF07
 Alarm 2 Register = FF0F
 Status Register = FF1F

Notes:

1. All codes are in hex.
2. When used with an 8-bit bus, only the two low order hex digits should be written to the command port; the "FF" prefix should be used only for a 16-bit data bus interface.

Figure 8. Load Data Pointer Commands

Sequencing is enabled by clearing Master Mode bit 14 (MM14) to zero. As shown in Figure 9 several types of sequencing are available depending on the data bus width being used and the initial Data Pointer value entered by command.

When E1 = 0 or E2 = 0 and G4, G2, G1 points to a Counter Group, the Data Pointer will proceed through the Element cycle. The Element field will automatically sequence through the three values 00, 01 and 10 starting with the value entered. When the transition from 10 to 00 occurs, the Group field will also be incremented by one. Note that the Element field in this case does not sequence to a value of 11. The Group field circulates only within the five Counter Group codes.

If E2, E1 = 11 and a Counter Group are selected, then only the Group field is sequenced. This is the Hold cycle. It allows the Hold registers to be sequentially accessed while bypassing the Mode and Load registers. The third type of sequencing is the Control cycle. If G4, G2, G1 = 111 and E2, E1 ≠ 11, the Element Pointer will be incremented through the values 00, 01 and 10, with no change to the Group Pointer.

When G4, G2, G1 = 111 and E2, E1 = 11, no incrementing takes place and only the Status register will be available through the Data port. Note that the Status register can also always be read directly through the Control port.

For all these auto-sequencing modes, if an 8-bit data bus is used, the Byte pointer will toggle after every data transfer to allow the least and most significant bytes to be transferred before the Element or Group fields are incremented.

Prefetch Circuit

To minimize the read access time to internal Am9513A registers, a prefetch circuit is used for all read operations through the Data port. Following each read or write operation through the Data port, the Data Pointer register is updated to point to the next register to be accessed. Immediately following this update, the new register data is transferred to a special prefetch latch at the interface pad logic. When the user performs a subsequent read of the Data port, the data bus drivers are enabled, outputting the prefetched data on the bus. Since the internal data register is accessed prior to the start of the read operation, its access time is transparent to the user. To keep the prefetched data consistent with the Data Pointer, prefetches are also performed after each write to the Data port and after execution of the "Load Data Pointer" com-

mand. The following rules should be kept in mind regarding Data port Transfers.

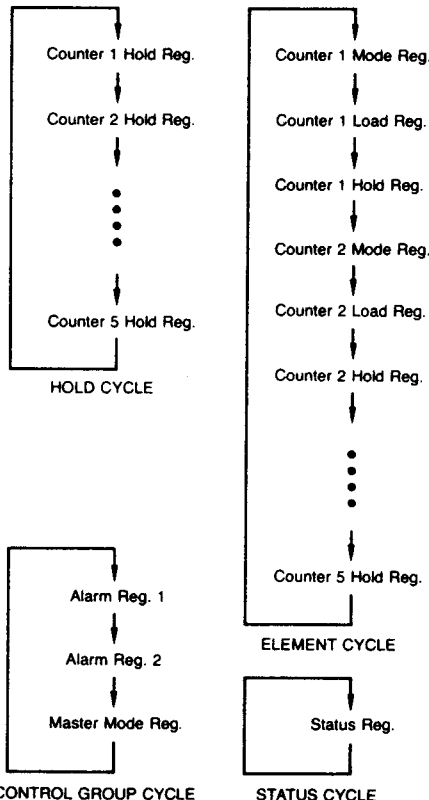

LS001240

Figure 9. Data Pointer Sequencing

1. The Data Pointer register should always be reloaded before reading from the Data port if a command, other than "Load Data Pointer," was issued to the Am9513A following the last Data port read or write. The Data Pointer does not have to be loaded again if the first Data port transaction after a command entry is a write, since the Data port write will automatically cause a new prefetch to occur.
2. Operating modes N, O, Q, R and X allow the user to save the counter contents in the Hold register by applying an active-going gate edge. If the Data Pointer register had been pointing to the Hold register in question, the prefetched value will not correspond to the new value saved in the Hold Register. To avoid reading an incorrect value, a new "Load Data Pointer" command should be issued before attempting to read the saved data. A Data port write (to another register) will also initiate a prefetch; subsequent reads will access the recently saved Hold register data. Many systems will use the "saving" gate edge to interrupt the host CPU. In systems such as this, the interrupt service routine should issue a "Load Data Pointer" command prior to reading the saved data.

Status Register

The 8-bit read-only Status register indicates the state of the Byte Pointer bit in the Data Pointer register and the state of the

OUT signal for each of the general counters. See Figures 10 and 17. The OUT signals reported are those internal to the chip after the polarity-select logic and just before the three-state interface buffer circuitry. Bits SR6 and SR7 may be 0 or 1.

The Status register OUT bit reflects an active-high or active-low TC output or a TC Toggled output, as programmed in the Output Control Field of the Counter Mode register. That is, it reflects the exact state of the OUT pin. When the low-impedance to Ground Output option (CM2-CM0 = 000) is selected, the Status register will reflect an active-high TC Output. When a high-impedance Output option (CM2-CM0 = 100) is selected, the Status register will reflect an active-low TC output.

For Counters 1 and 2, the OUT pin will reflect the comparator output if the comparators are enabled. The Status register bit and OUT pin are active-high if CM2 = 0 and active-low if CM2 = 1. When the high-impedance option is selected and the comparator is enabled, the status register bit will reflect an active-high comparator output. When the low-impedance to Ground option is selected and the comparator is enabled, the status register bit will reflect an active-low comparator output.

The Status register is normally accessed by reading the Control port (see Figure 6) but may also be read via the Data port as part of the Control Group.

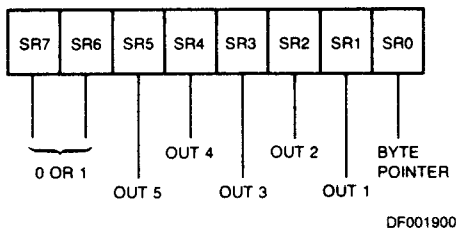

Figure 10. Status Register Bit Assignments

DATA PORT REGISTERS

Counter Logic Groups

As shown in Figures 4 and 5, each of the five Counter Logic Groups consists of a 16-bit general counter with associated control and output logic, a 16-bit Load register, a 16-bit Hold register and a 16-bit Mode register. In addition, Counter Groups 1 and 2 also include 16-bit Comparators and 16-bit Alarm registers. The comparator/alarm functions are controlled by the Master Mode register. The operation of the Counter Mode registers is the same for all five counters. The host CPU has both read and write access to all registers in the Counter Logic Groups through the Data port. The counter itself is never directly accessed.

Load Register

The 16-bit read/write Load register is used to control the effective length of the general counter. Any 16-bit value may be written into the Load register. That value can then be transferred into the counter each time the Terminal Count (TC) occurs. "Terminal Count" is defined as that period of time when the counter contents would have been zero if an external value had not been transferred into the counter. Thus, the terminal count frequency can be the input frequency

divided by the value in the Load register. In all operating modes, either the Load or Hold register will be transferred into the counter when TC occurs. In cases where values are being accumulated in the counter, the Load register action can become transparent by filling the Load register with all zeros.

Hold Register

The 16-bit read/write Hold register is dual-purpose. It can be used in the same way as the Load register, thus offering an alternate source for module definition for the counter. The Hold register may also be used to store accumulated counter values for later transfer to the host processor. This allows the count to be sampled while the counting process proceeds without interruption. Transfer of the counter contents into the Hold register is accomplished by the hardware interface in some operating modes or by software commands at any time.

Counter Mode Register

The 16-bit read/write Counter Mode register controls the gating, counting, output and source select functions within each Counter Logic Group. The "Counter Mode Control Options" section of this document describes the detailed control options available. Figure 16 shows the bit assignments for the Counter Mode registers.

Alarm Registers and Comparators

Added functions are available in the Counter Logic Groups for Counters 1 and 2 (see Figure 4). Each contains a 16-bit Alarm register and a 16-bit Comparator. When the value in the counter reaches the value in the Alarm register, the Comparator output will go true. The Master Mode register contains control bits to individually enable/disable the comparators. When enabled, the comparator output appears on the OUT pin of the associated counter in place of the normal counter output. The output will remain true as long as the comparison is true, that is, until the next input causes the count to change. The polarity of the Comparator output will be active-high if the Output Control field of the Counter Mode register is 001 or 010 and active-low if the Output Control field is 101.

MASTER MODE CONTROL OPTIONS

The 16-bit Master Mode (MM) register is used to control those internal activities that are not controlled by the individual Counter Mode registers. This includes frequency control, Time-of-Day operation, comparator controls, data bus width and data pointer sequencing. Figure 11 shows the bit assignments for the Master Mode register. This section describes the use of each control field.

Master Mode register bits MM12, MM13 and MM14 can be individually set and reset using commands issued to the Command register. In addition, they can all be changed by writing directly to the Master Mode register.

After power-on reset or a Master Reset command, the Master Mode register is cleared to an all zero condition. This results in the following configuration:

- Time-of-Day disabled
- Both Comparators disabled
- FOUT Source is frequency F1
- FOUT Divider set for divide-by-16
- FOUT gated on
- Data Bus 8 bits wide
- Data Pointer Sequencing enabled
- Frequency Scaler divides in binary

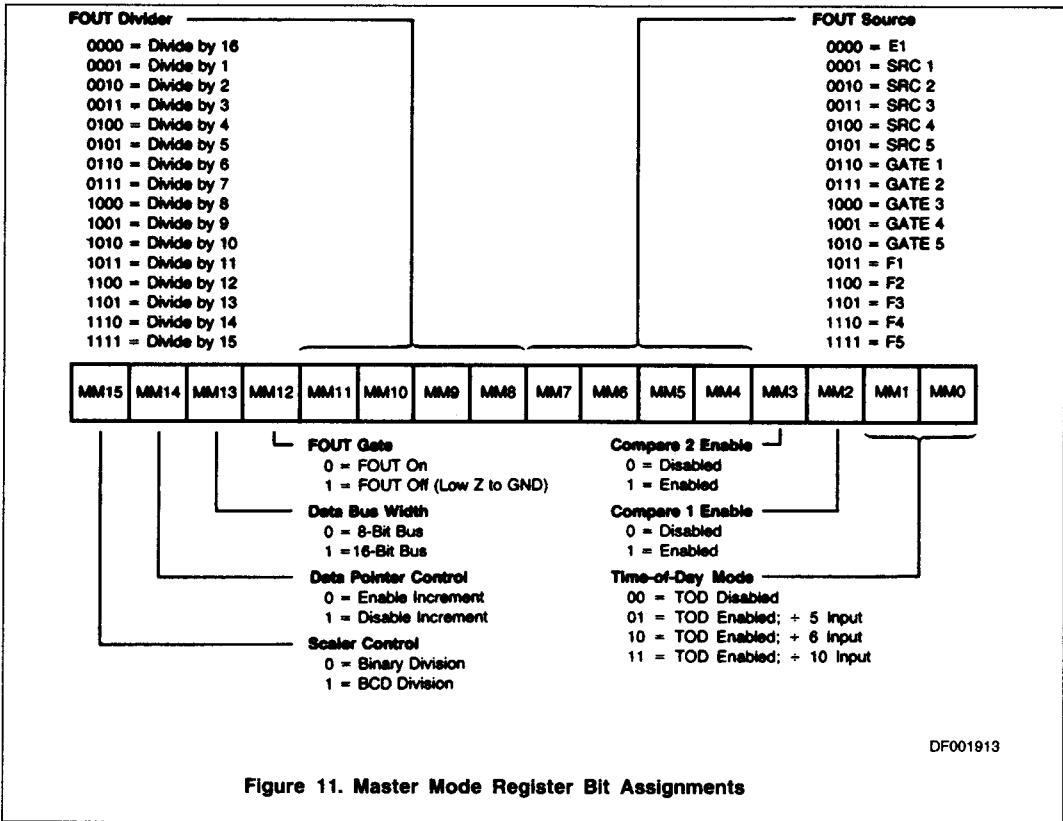

Figure 11. Master Mode Register Bit Assignments

Time-of-Day

Bits MM0 and MM1 of the Master Mode register specify the Time-of-Day (TOD) options. When MM0 = 0 and MM1 = 0, the special logic used to implement TOD is disabled, and Counters 1 and 2 will operate in exactly the same way as Counters 3, 4 and 5. When MM0 = 1 or MM1 = 1, additional counter decoding and control logic is enabled on Counters 1 and 2, which causes their decades to turn over at the counts that generate appropriate 24-hour TOD accumulations. For additional information, see the Time-of-Day chapter in the 9513A System timing controller technical manual.

Comparator Enable

Bits MM2 and MM3 control the Comparators associated with Counters 1 and 2. When a Comparator is enabled, its output is substituted for the normal counter output on the associated OUT1 or OUT2 pin. The comparator output will be active-high if the output control field of the Counter Mode register is 001 or 010 and active-low for a code of 101. Once the compare output is true, it will remain so until the count changes and the comparison therefore goes false.

The two Comparators can always be used individually in any operating mode. One special case occurs when the Time-of-Day option is revoked and both Comparators are enabled. The operation of Comparator 2 will then be conditioned by Comparator 1 so that a full 32-bit compare must be true in order to generate a true signal on OUT2. OUT1 will continue, as usual, to reflect the state of the 16-bit comparison between Alarm 1 and Counter 1.

FOUT Source

Master Mode bits MM4 through MM7 specify the source input for the FOUT divider. Fifteen inputs are available for selection, and they include the five Source pins, the five Gate pins and the five internal frequencies derived from the oscillator. The 16th combination of the four control bits (all zeros) is used to assure that an active frequency is available at the input to the FOUT divider following reset.

FOUT Divider

Bits MM8 through MM11 specify the dividing ratio for the FOUT Divider. The FOUT source (selected by bits MM4 through MM7) is divided by an integer value between 1 and 16, inclusive, and is then passed to the FOUT output buffer. After power-on or reset, the FOUT divider is set to divide-by-16.

FOUT Gate

Master Mode bit MM12 provides a software gating capability for the FOUT signal. When MM12 = 1, FOUT is off and in a low-impedance state to ground. MM12 may be set or cleared in conjunction with the loading of the other bits in the Master Mode register; alternatively, there are commands that allow MM12 to be individually set or cleared directly without changing any other Master Mode bits. After power-up or reset, FOUT is gated on.

When changing the FOUT divider ratio or FOUT source, transient pulses as short as half the period of the FOUT source may appear on the FOUT pin. Turning the FOUT gate on or off can also generate a transient. This should be considered when using FOUT as a system clock source.

Bus Width

Bit MM13 controls the multiplexer at the data bus interface in order to configure the part for an 8-bit or 16-bit external bus. The internal bus is always 16-bits wide. When MM13 = 1, 16-bit data is transferred directly between the internal bus and all 16 of the external bus lines. In this configuration, the Byte Pointer bit in the Data Pointer register remains set at all times. When MM13 = 0, 16-bit internal data is transferred a byte at a time to and from the eight low-order external data bus lines. The Byte Pointer bit toggles with each byte transfer in this mode.

When the Am9513A is set to operate with an 8-bit data bus width, pins DB8 through DB15 are not used for the data bus and are available for other functions. Pins DB13 through DB15 should be tied high. Pins DB8 through DB12 are used as auxiliary gating inputs and are labeled GATE1A through GATE5A respectively. The auxiliary gate pin, GATENA, is logically ANDed with the gate input to Counter N, as shown in Figure 12. The output of the AND gate is then used as the gating signal for Counter N.

Data Pointer Sequencing

Bit MM14 controls the Data Pointer logic to enable or disable the automatic sequencing functions. When MM14 = 1, the contents of the Data Pointer can be changed only directly by entering a command. When MM14 = 0, several types of automatic sequencing of the Data Pointer are available. These are described in the Data Pointer register section of this document.

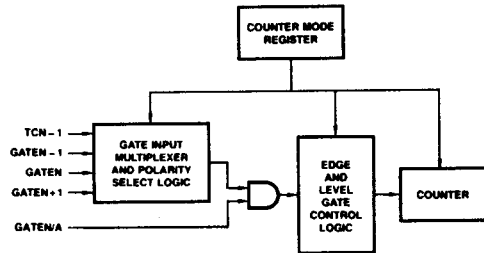

DF001920

Figure 12. Gating Control

Thus, the host processor, by controlling MM14, may repetitively read/write a single internal location, or may sequentially read/write groups of locations. Bit MM14 can be loaded by writing to the Master Mode register or can be set or cleared by software command.

Scaler Ratios

Master Mode bit MM15 controls the counting configuration of the Frequency Scaler counter. When MM15 = 0, the Scaler divides the oscillator frequency in binary steps so that each subfrequency is 1/16 of the preceding frequency. When MM15 = 1, the Scaler divides in BCD steps so that adjacent frequencies are related by ratios of 10 instead of 16 (see Figure 13).

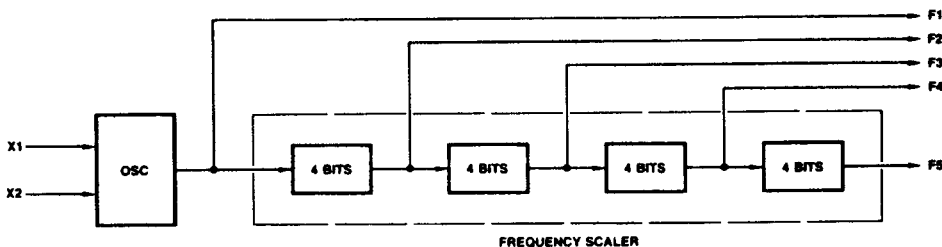

AF002541

Frequency	BCD Scaling MM15 = 1	Binary Scaling MM15 = 0
F1	OSC	OSC
F2	$F1 \div 10$	$F1 \div 16$
F3	$F1 \div 100$	$F1 \div 256$
F4	$F1 \div 1,000$	$F1 \div 4,096$
F5	$F1 \div 10,000$	$F1 \div 65,536$

Figure 13. Frequency Scaler Ratios

Counter Mode	A	B	C	D	E	F	G	H	I	J	K	L
Special Gate (CM7)	0	0	0	0	0	0	0	0	0	0	0	0
Reload Source (CM6)	0	0	0	0	0	0	1	1	1	1	1	1
Repetition (CM5)	0	0	0	1	1	1	0	0	0	1	1	1
Gate Control (CM15–CM13)	000	LEVEL	EDGE	000	LEVEL	EDGE	000	LEVEL	EDGE	000	LEVEL	EDGE
Count to TC once, then disarm	X	X	X									
Count to TC twice, then disarm							X	X	X			
Count to TC repeatedly without disarming				X	X	X				X	X	X
Gate input does not gate counter input	X			X			X			X		
Count only during active gate level		X			X			X			X	
Start count on active gate edge and stop count on next TC			X			X						
Start count on active gate edge and stop count on second TC									X			X
No hardware retriggering	X	X	X	X	X	X	X	X	X	X	X	X
Reload counter from Load register on TC	X	X	X	X	X	X						
Reload counter on each TC, alternating reload source between Load and Hold registers							X	X	X	X	X	X
Transfer Load register into counter on each TC that gate is LOW, transfer Hold register into counter on each TC that gate is HIGH.												
On active gate edge transfer counter into Hold register and then reload counter from Load register												
Counter Mode	M	N	O	P	Q	R	S	T	U	V	W	X
Special Gate (CM7)	1	1	1	1	1	1	1	1	1	1	1	1
Reload Source (CM6)	0	0	0	0	0	0	1	1	1	1	1	1
Repetition (CM5)	0	0	0	1	1	1	0	0	0	1	1	1
Gate Control (CM15–CM13)	000	LEVEL	EDGE	000	LEVEL	EDGE	000	LEVEL	EDGE	000	LEVEL	EDGE
Count to TC once, then disarm		X	X									
Count to TC twice, then disarm							X					
Count to TC repeatedly without disarming					X	X				X		X
Gate input does not gate counter input							X			X		
Count only during active gate level		X			X							
Start count on active gate edge and stop count on next TC			X			X						X
Start count on active gate edge and stop count on second TC												
No hardware retriggering							X			X		X
Reload counter from Load register on TC		X	X		X	X						X
Reload counter on each TC, alternating reload source between Load and Hold registers.												
Transfer Load register into counter on each TC that gate is LOW, transfer Hold register into counter on each TC that gate is HIGH.							X			X		
On active gate edge transfer counter into Hold register and then reload counter from Load register		X	X		X	X						
On active gate edge transfer counter into Hold register, but counting continues												X

Notes: 1. Counter modes M, P, T, U and W are reserved and should not be used.
2. Mode X is available for Am9513A only.

Figure 14. Counter Mode Operating Summary

COUNTER MODE DESCRIPTIONS

Counter Mode register bits CM15–CM13 and CM7–CM5 select the operating mode for each counter (see Figure 14). To simplify references to a particular mode, each mode is assigned a letter from A through X. Representative waveforms for the counter modes are illustrated in Figures 15a through 15v. (Because the letter suffix in the figure number is keyed to the mode, Figures 15m, 15p, 15t, 15u and 15w do not exist.) The figures assume down counting on rising source edges. Those modes which automatically disarm the counter (CM5 = 0) are shown with the \overline{WR} plus entering the required ARM command; for modes which count repetitively (CM5 = 1),

the ARM command is omitted. The retriggering modes (N, O, Q and R) are shown with one retrigger operation. Both a TC output waveform and a TC Toggled output waveform are shown for each mode. The symbols L and H are used to represent count values equal to the Load and Hold register contents, respectively. The symbols K and N represent arbitrary count values. For each mode, the required bit pattern in the Counter Mode register is shown; "don't care" bits are marked "X." These figures are designed to clarify the mode descriptions; the Am9513A Electrical Specification should be used as the authoritative reference for timing relationships between signals.

To keep the following mode descriptions concise and to the point, the phrase "source edges" is used to refer to active-going source edges only, not to inactive-going edges. Similarly, the phrase "gate edges" refers only to active-going gate edges. Also, again to avoid verbosity and euphuism, the descriptions of some modes state that a counter is stopped or disarmed "on a TC, inhibiting further counting." As is fully explained in the TC section of this document, for these modes the counter is actually stopped or disarmed following the active-going source edge which drives the counter out of TC. In other words, since a counter in the TC state always counts, irrespective of its gating or arming status, the stopping or disarming of the count sequence is delayed until TC is terminated.

MODE A

Software-Triggered Strobe with No Hardware Gating

CM15	CM14	CM13	CM12	CM11	CM10	CM9	CM8
0	0	0	X	X	X	X	X

CM7	CM6	CM5	CM4	CM3	CM2	CM1	CM0
0	0	0	X	X	X	X	X

Mode A, shown in Figure 15a, is one of the simplest operating modes. The counter will be available for counting source edges when it is issued an ARM command. On each TC, the counter will reload from the Load register and automatically disarm itself, inhibiting further counting. Counting will resume when a new ARM command is issued.

MODE B

Software-Triggered Strobe with Level Gating

CM15	CM14	CM13	CM12	CM11	CM10	CM9	CM8
LEVEL			X	X	X	X	X

CM7	CM6	CM5	CM4	CM3	CM2	CM1	CM0
0	0	0	X	X	X	X	X

Mode B, shown in Figure 15b, is identical to Mode A except that source edges are counted only when the assigned Gate is active. The counter must be armed before counting can occur. Once armed, the counter will count all source edges which occur while the Gate is active and disregard those edges which occur while the Gate is inactive. This permits the Gate to turn the count process on and off. On each TC the counter will reload from the Load register and automatically disarm itself, inhibiting further counting until a new ARM command is issued.

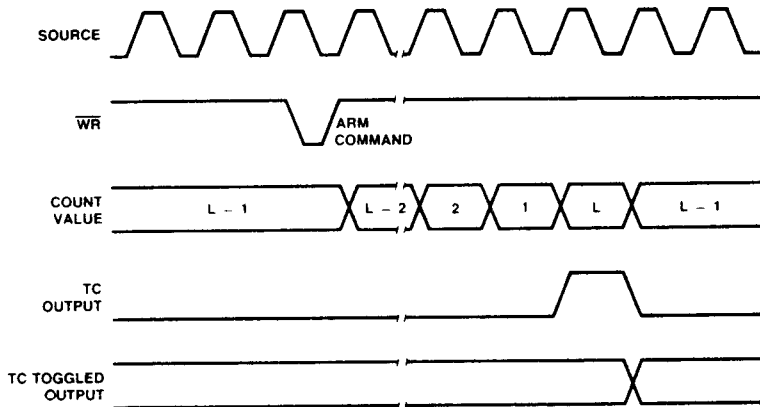

WF004590

Figure 15a. Mode A Waveforms

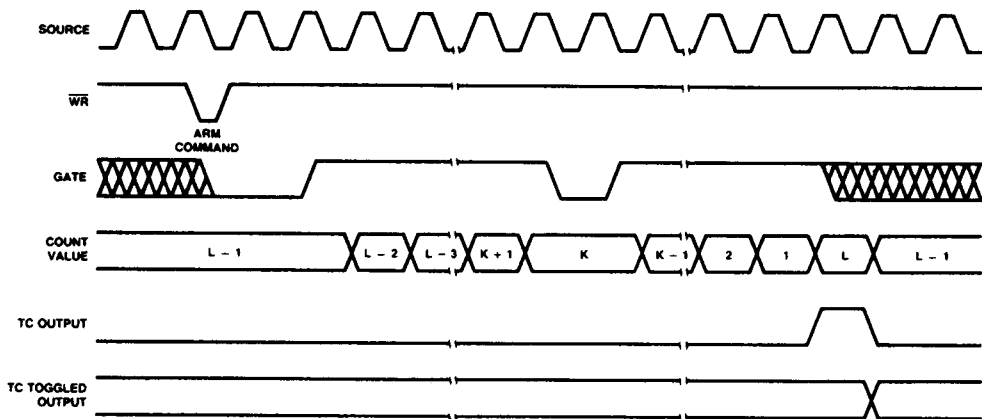

WF004600

Figure 15b. Mode B Waveforms

MODE C

Hardware-Triggered Strobe

CM15	CM14	CM13	CM12	CM11	CM10	CM9	CM8
EDGE			X	X	X	X	X

CM7	CM6	CM5	CM4	CM3	CM2	CM1	CM0
0	0	0	X	X	X	X	X

Mode C, shown in Figure 15c, is identical to Mode A, except that counting will not begin until a Gate edge is applied to the

armed counter. The counter must be armed before application of the triggered Gate edge; Gate edges applied to a disarmed counter are disregarded. The counter will start counting on the first source edge after the triggering Gate edge and will continue counting until TC. At TC, the counter will reload from the Load register and automatically disarm itself. Counting will then remain inhibited until a new ARM command and a new Gate edge are applied in that order. Note that after application of a triggered Gate edge, the Gate input will be disregarded for the remainder of the count cycle. This differs from Mode B, where the Gate can be modulated throughout the count cycle to stop and start the counter.

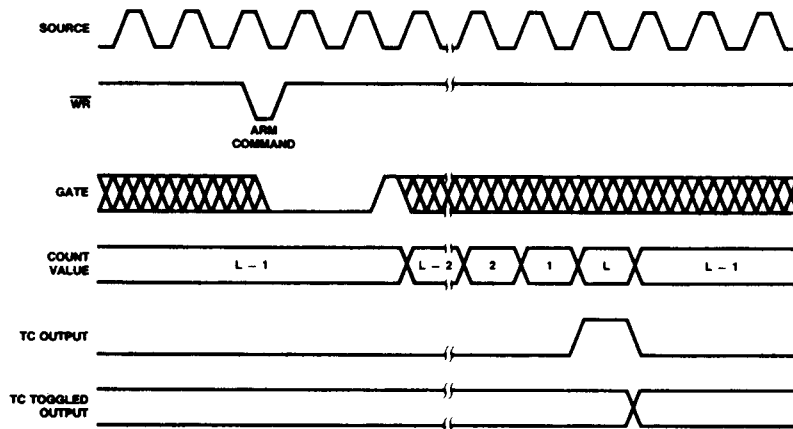

WF004610

Figure 15c. Mode C Waveforms

MODE D

Rate Generator with No Hardware Gating

CM15	CM14	CM13	CM12	CM11	CM10	CM9	CM8
0	0	0	X	X	X	X	X

CM7	CM6	CM5	CM4	CM3	CM2	CM1	CM0
0	0	1	X	X	X	X	X

Mode D, shown in Figure 15d, is typically used in frequency generation applications. In this mode, the Gate input does not affect counter operation. Once armed, the counter will count to TC repetitively. On each TC, the counter will reload itself from the Load register; hence, the Load register value determines the time between TCs. A square wave rate generator may be obtained by specifying the TC Toggled output mode in the Counter Mode register.

MODE E

Rate Generator with Level Gating

CM15	CM14	CM13	CM12	CM11	CM10	CM9	CM8
LEVEL			X	X	X	X	X

CM7	CM6	CM5	CM4	CM3	CM2	CM1	CM0
0	0	1	X	X	X	X	X

Mode E, shown in Figure 15e, is identical to Mode D, except the counter will only count those source edges which occur while the Gate input is active. This feature allows the counting process to be enabled and disabled under hardware control. A square wave rate generator may be obtained by specifying the TC Toggled output mode.

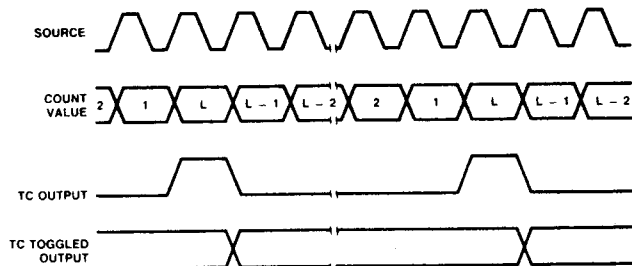

WF004620

Figure 15d. Mode D Waveforms

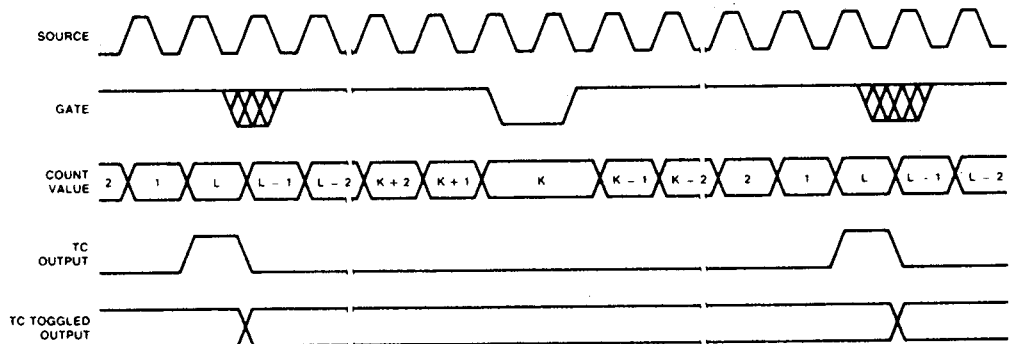

WF004630

Figure 15e. Mode E Waveforms

2

MODE F

Non-Retriggerable One-Shot

CM15	CM14	CM13	CM12	CM11	CM10	CM9	CM8
EDGE			X	X	X	X	X

CM7	CM6	CM5	CM4	CM3	CM2	CM1	CM0
0	0	1	X	X	X	X	X

Mode F, shown in Figure 15f, provides a non-retriggerable one-shot timing function. The counter must be armed before it will function. Application of a Gate edge to the armed counter will enable counting. When the counter reaches TC, it will reload itself from the Load register. The counter will then stop counting, awaiting a new Gate edge. Note that unlike Mode C, a new ARM command is not needed after TC, only a new Gate edge. After application of a triggering Gate edge, the Gate input is disregarded until TC.

MODE G

Software-Triggerred Delayed Pulse One-Shot

CM15	CM14	CM13	CM12	CM11	CM10	CM9	CM8
0	0	0	X	X	X	X	X

CM7	CM6	CM5	CM4	CM3	CM2	CM1	CM0
0	1	0	X	X	X	X	X

In Mode G, the Gate does not affect the counter's operation. Once armed, the counter will count to TC twice and then automatically disarm itself. For most applications, the counter will initially be loaded from the Load register either by a LOAD command or by the last TC of an earlier timing cycle. Upon counting to the first TC, the counter will reload itself from the Hold register. Counting will proceed until the second TC, when the counter will reload itself from the Load register and automatically disarm itself, inhibiting further counting. Counting can be resumed by issuing a new ARM command. A software-triggerred delayed pulse one-shot may be generated by specifying the TC Toggled output mode in the Counter Mode register. The initial counter contents control the delay from the ARM command until the output pulse starts. The Hold register contents control the pulse duration. Mode G is shown in Figure 15g.

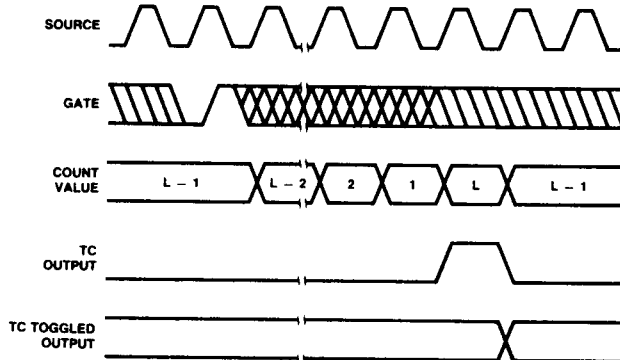

WF004640

Figure 15f. Mode F Waveforms

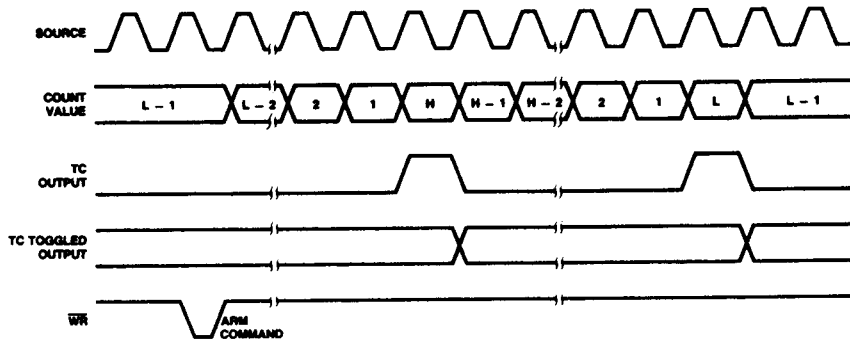

WF004650

Figure 15g. Mode G Waveforms

MODE H

Software-Triggerred Delayed Pulse One-Shot with Hardware Gating

CM15	CM14	CM13	CM12	CM11	CM10	CM9	CM8
LEVEL			X	X	X	X	X

CM7	CM6	CM5	CM4	CM3	CM2	CM1	CM0
0	1	0	X	X	X	X	X

Mode H, shown in Figure 15h, is identical to Mode G except that the Gate input is used to qualify which source edges are to be counted. The counter must be armed for counting to occur. Once armed, the counter will count all source edges that occur while the Gate is active. This permits the Gate to turn the count process on and off. As with Mode G, the counter will be reloaded from the Hold register on the first TC and reloaded from the Load register and disarmed on the second TC. This mode allows the Gate to control the extension of both the initial output delay time and the pulse width.

MODE I

Hardware-Triggerred Delayed Pulse Strobe

CM15	CM14	CM13	CM12	CM11	CM10	CM9	CM8
EDGE			X	X	X	X	X

CM7	CM6	CM5	CM4	CM3	CM2	CM1	CM0
0	1	0	X	X	X	X	X

Mode I, shown in Figure 15i, is identical to Mode G, except that counting will not begin until a Gate edge is applied to an armed counter. The counter must be armed before application of the triggering Gate edge; Gate edges applied to a disarmed counter are disregarded. An armed counter will start counting on the first source edge after the triggering Gate edge. Counting will then proceed in the same manner as in Mode G. After the second TC, the counter will disarm itself. An ARM command and Gate edge must be issued in this order to restart counting. Note that after application of a triggering Gate edge, the Gate input will be disregarded until the second TC. This differs from Mode H, where the Gate can be modulated throughout the count cycle to stop and start the counter.

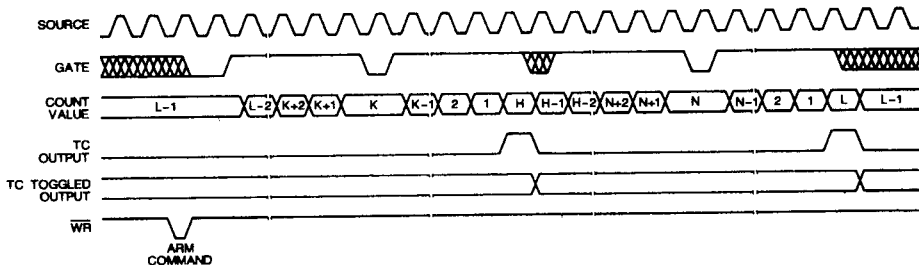

WF004661

Figure 15h. Mode H Waveforms

2

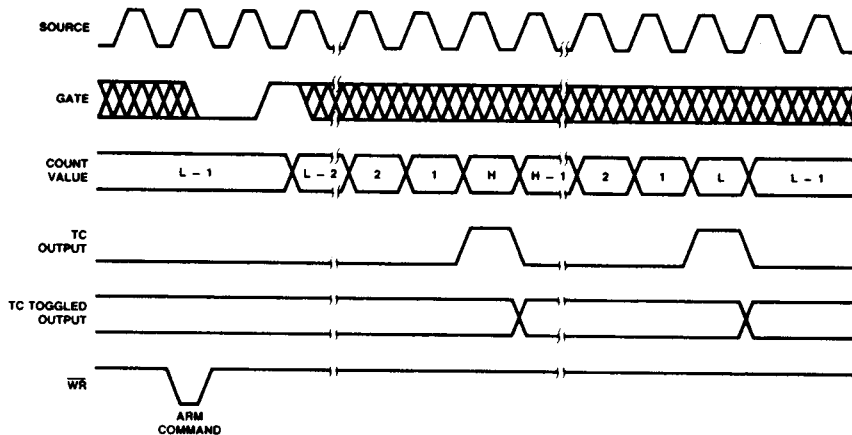

WF004670

Figure 15i. Mode I Waveforms

MODE J

Variable Duty Cycle Rate Generator with No Hardware Gating

CM15	CM14	CM13	CM12	CM11	CM10	CM9	CM8
0	0	0	X	X	X	X	X

CM7	CM6	CM5	CM4	CM3	CM2	CM1	CM0
0	1	1	X	X	X	X	X

Mode J, shown in Figure 15j, will find the greatest usage in frequency generation applications with variable duty cycle requirements. Once armed, the counter will count continuously until it is issued a DISARM command. On the first TC, the counter will be reloaded from the Hold register. Counting will then proceed until the second TC at which time the counter will be reloaded from the Load register. Counting will continue, with the reload source alternating on each TC, until a DISARM command is issued to the counter. (The third TC reloads from the Hold register, the fourth TC reloads from the Load register, etc.) A variable duty cycle output can be generated by specifying the TC Toggled output in the Counter Mode register. The Load and Hold values then directly control the output duty cycle, with high resolution available when relatively high count values are used.

MODE K

Variable Duty Cycle Rate Generator with Level Gating

CM15	CM14	CM13	CM12	CM11	CM10	CM9	CM8
LEVEL			X	X	X	X	X

CM7	CM6	CM5	CM4	CM3	CM2	CM1	CM0
0	1	1	X	X	X	X	X

Mode K, shown in Figure 15k, is identical to Mode J, except that source edges are only counted when the Gate is active. The counter must be armed for counting to occur. Once armed, the counter will count all source edges which occur while Gate is active and disregard those source edges which occur while the Gate is inactive. This permits the Gate to turn the count process on and off. As with Mode J, the reload source used will alternate on each TC, starting with the Hold register on the first TC after any ARM command. When the TC Toggled output is used, this mode allows the Gate to modulate the duty cycle of the output waveform. It can affect both the HIGH and LOW portions of the output waveform.

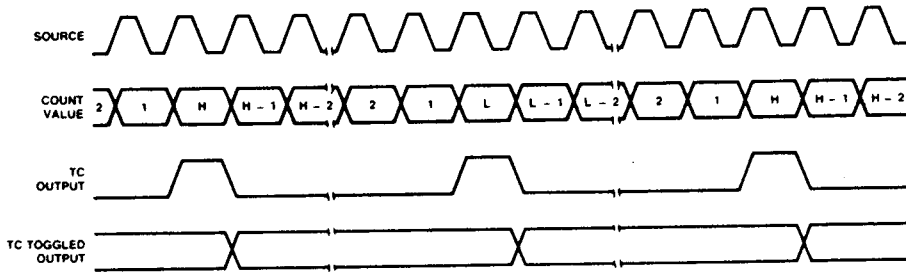

Figure 15j. Mode J Waveforms

WF004680

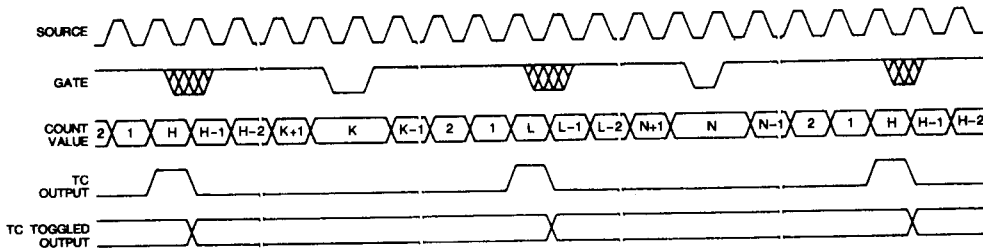

Figure 15k. Mode K Waveforms

WF004691

MODE L

Hardware-Triggered Delayed Pulse One-Shot

CM15	CM14	CM13	CM12	CM11	CM10	CM9	CM8
EDGE			X	X	X	X	X

CM7	CM6	CM5	CM4	CM3	CM2	CM1	CM0
0	1	1	X	X	X	X	X

Mode L, shown in Figure 15l, is similar to Mode J except that counting will not begin until a Gate edge is applied to an armed counter. The counter must be armed before application of the triggering Gate edge; Gate edges applied to a disarmed counter are disregarded. The counter will start counting source edges after the triggering Gate edge, and counting will proceed until the second TC. Note that after application of a triggering Gate edge, the Gate input will be disregarded for the remainder of the count cycle. This differs from Mode K, where the gate can be modulated throughout the count cycle to stop and start the counter. On the first TC after application of the triggering Gate edge, the counter will be reloaded from the Hold register. On the second TC, the counter will be reloaded from the Load register, and counting will stop until a new gate edge is issued to the counter. Note that unlike Mode K, new Gate edges are required after every second TC to continue counting.

MODE N

Software-Triggered Strobe with Level Gating and Hardware Retriggering

CM15	CM14	CM13	CM12	CM11	CM10	CM9	CM8
LEVEL			X	X	X	X	X

CM7	CM6	CM5	CM4	CM3	CM2	CM1	CM0
1	0	0	X	X	X	X	X

Mode N, shown in Figure 15n, provides a software-triggered strobe with level gating that is also hardware retriggerable. The counter must be issued an ARM command before counting can occur. Once armed, the counter will count all source edges which occur while the gate is active and disregard those source edges which occur while the Gate is inactive. This permits the Gate to turn the count process on and off. After the issuance of the ARM command and the application of an active Gate, the counter will count to TC. Upon reaching TC, the counter will reload from the Load register and automatically disarm itself, inhibiting further counting. Counting will resume upon the issuance of a new ARM command. All active-going Gate edges issued to an armed counter will cause a retrigger operation. Upon application of the Gate edge, the counter contents will be saved in the Hold register. On the first qualified source edge after application of the retriggering gate edge, the contents of the Load register will be transferred into the counter. Counting will resume on the second qualified source edge after the retriggering Gate edge. Qualified source edges are active-going edges which occur while the Gate is active.

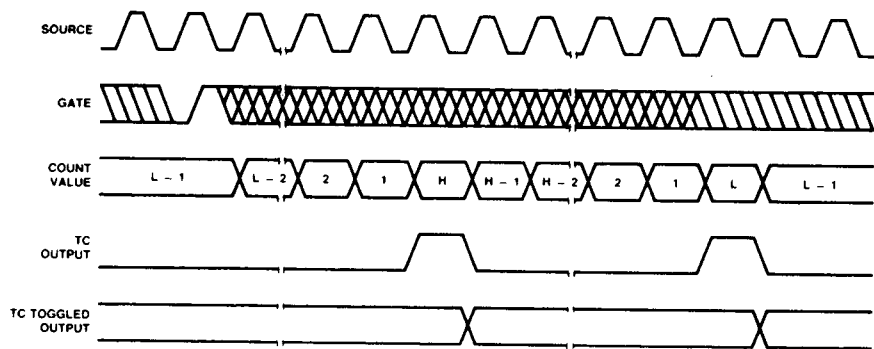

WF004700

Figure 15l. Mode L Waveforms

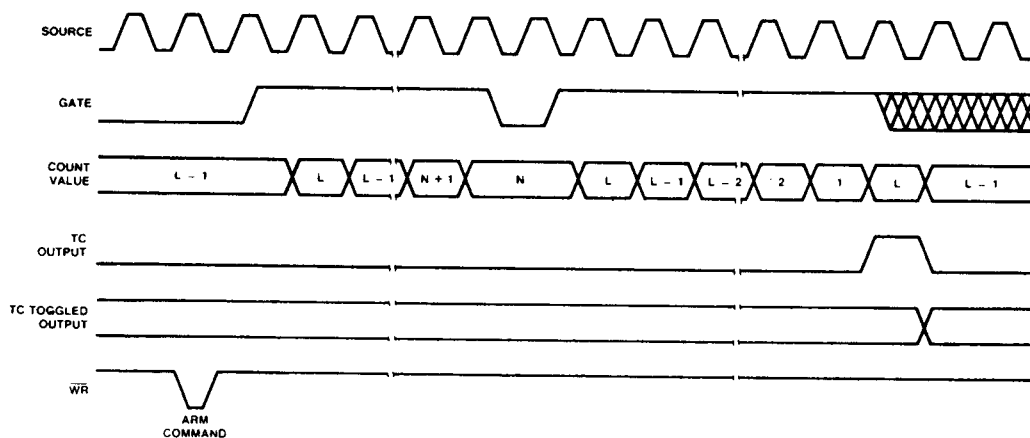

WF004710

Figure 15n. Mode N Waveforms

MODE O

Software-Triggered Strobe with Edge Gating and Hardware Retriggering

CM15	CM14	CM13	CM12	CM11	CM10	CM9	CM8
EDGE			X	X	X	X	X

CM7	CM6	CM5	CM4	CM3	CM2	CM1	CM0
1	0	0	X	X	X	X	X

Mode O, shown in Figure 15o, is similar Mode N, except that counting will not begin until an active-going Gate edge is applied to an armed counter and the Gate level is not used to

modulate counting. The counter must be armed before application of the triggering Gate edge; Gate edges applied to a disarmed counter are disregarded. Irrespective of the Gate level, the counter will count all source edges after the triggering Gate edge until the first TC. On the first TC, the counter will be reloaded from the Load register and disarmed. A new ARM command and a new Gate edge must be applied in that order to initiate a new counting cycle. Unlike Modes C, F, I and L, which disregard the Gate input once counting starts, in Mode O the count process will be retriggered on all active-going Gate edges, including the first Gate edge used to start the counter. On each retriggering Gate edge, the counter contents will be transferred into the Hold register. On the first source edge after the retriggering Gate edge, the Load register contents will be transferred into the counter. Counting will resume on the second-source edge after a retrigger.

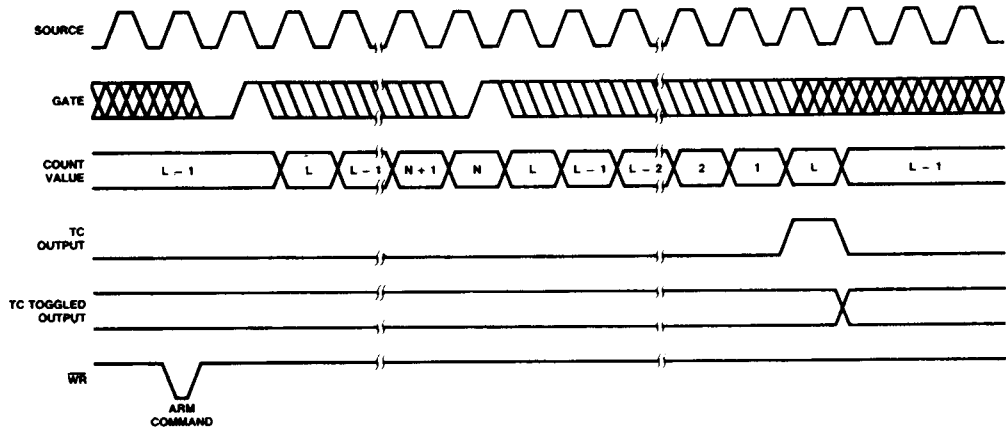

WF004720

Figure 15o. Mode O Waveforms

MODE Q

Rate Generator with Synchronization (Event Counter with Auto-Read/Reset)

CM15	CM14	CM13	CM12	CM11	CM10	CM9	CM8
			X	X	X	X	X
LEVEL							

CM7	CM6	CM5	CM4	CM3	CM2	CM1	CM0
1	0	1	X	X	X	X	X

Mode Q, shown in Figure 15q, provides a rate generator with synchronization or an event counter with auto-read/reset. The counter must first be issued an ARM command before counting can occur. Once armed, the counter will count all source edges which occur while the Gate is active and disregard those edges which occur while the Gate is inactive. This permits the Gate to turn the count process on and off. After the issuance of an ARM command and the application of an active Gate, the counter will count to TC repetitively. On each TC, the counter will reload itself from the Load register. The counter may be retriggered at any time by presenting an active-going Gate edge to the Gate input. The retriggering Gate edge will transfer the contents of the counter into the Hold register. The first qualified source edge after the retriggering Gate edge will transfer the contents of the Load register into the Counter. Counting will resume on the second qualified source edge after the retriggering Gate edge. Qualified source edges are active-going edges which occur while the Gate is active.

MODE R

Retriggerable One-Shot

CM15	CM14	CM13	CM12	CM11	CM10	CM9	CM8
EDGE			X	X	X	X	X

CM7	CM6	CM5	CM4	CM3	CM2	CM1	CM0
1	0	1	X	X	X	X	X

Mode R, shown in Figure 15r, is similar to Mode Q, except that edge gating rather than level gating is used. In other words, rather than use the Gate level to qualify which source edges to count, Gate edges are used to start the counting operation. The counter must be armed before application of the triggering Gate edge; Gate edges applied to a disarmed counter are disregarded. After application of a Gate edge, an armed counter will count all source edges until TC, irrespective of the Gate level. On the first TC, the counter will be reloaded from the Load register and stopped. Subsequent counting will not occur until a new Gate edge is applied. All Gate edges applied to the counter, including the first used to trigger counting, initiate a retrigger operation. Upon application of a Gate edge, the counter contents are saved in the Hold register. On the first source edge after the retriggering Gate edge, the Load register contents will be transferred into the counter. Counting will resume on the second source edge after the retriggering Gate edge.

2

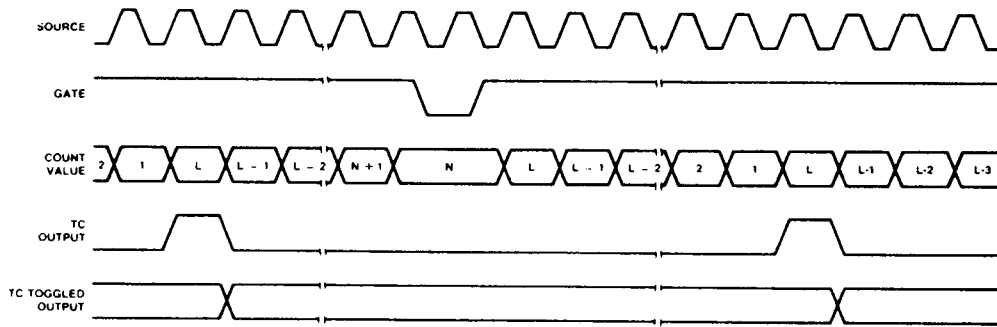

WF004730

Figure 15q. Mode Q Waveforms

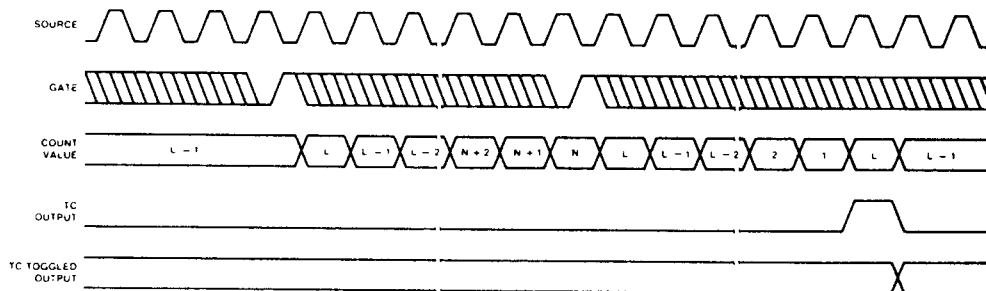

WF004740

Figure 15r. Mode R Waveforms

MODE S

RELOAD SOURCE

CM15	CM14	CM13	CM12	CM11	CM10	CM9	CM8
0	0	0	X	X	X	X	X

CM7	CM6	CM5	CM4	CM3	CM2	CM1	CM0
1	1	0	X	X	X	X	X

In this mode, the reload source for LOAD commands (irrespective of whether the counter is armed or disarmed) and for TC-initiated reloads is determined by the Gate input. The Gate input in Mode S is used only to select the reload source, not to start or modulate counting. When the Gate is Low, the Load register is used; when the Gate is High, the Hold register is used. Note the Low-Load, High-Hold mnemonic convention. Once armed, the counter will count to TC twice and then disarm itself. On each TC, the counter will be reloaded from the reload source selected by the Gate. Following the second TC, an ARM command is required to start a new counting cycle. Mode S is shown in Figure 15s.

MODE V

Frequency-Shift Keying

CM15	CM14	CM13	CM12	CM11	CM10	CM9	CM8
0	0	0	X	X	X	X	X

CM7	CM6	CM5	CM4	CM3	CM2	CM1	CM0
1	1	1	X	X	X	X	X

Mode V, shown in Figure 15v, provides frequency-shift keying modulation capability. Gate operation in this mode is identical to that in Mode S. If the Gate is Low, a LOAD command or a TC-induced reload will reload the counter from the Load register. If the Gate is HIGH, LOADs and reloads will occur from the Hold register. The polarity of the Gate only selects the reload source; it does not start or modulate counting. Once armed, the counter will count repetitively to TC. On each TC, the counter will reload itself from the register determined by the polarity of the Gate. Counting will continue in this manner until a DISARM command is issued to the counter. Frequency shift keying may be obtained by specifying a TC Toggled output mode in the Counter Mode register. The switching of frequencies is achieved by modulating the Gate.

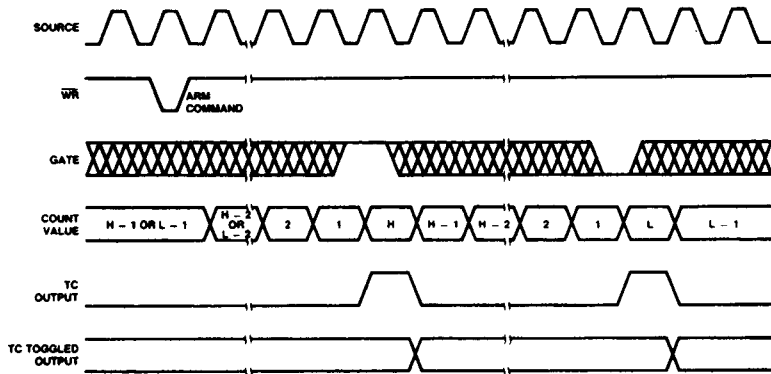

WF004751

Figure 15s. Mode S Waveforms

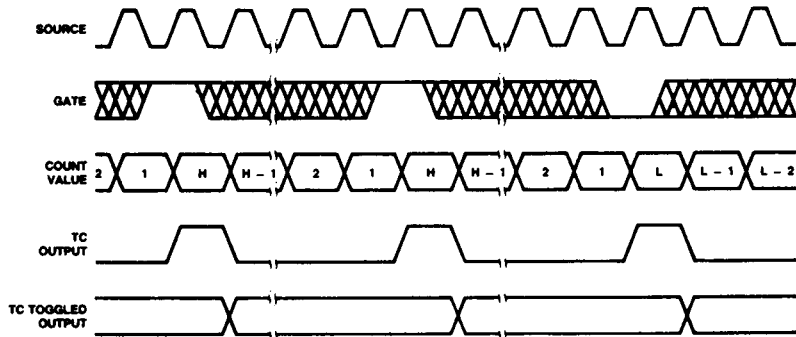

WF004760

Figure 15v. Mode V Waveforms

2

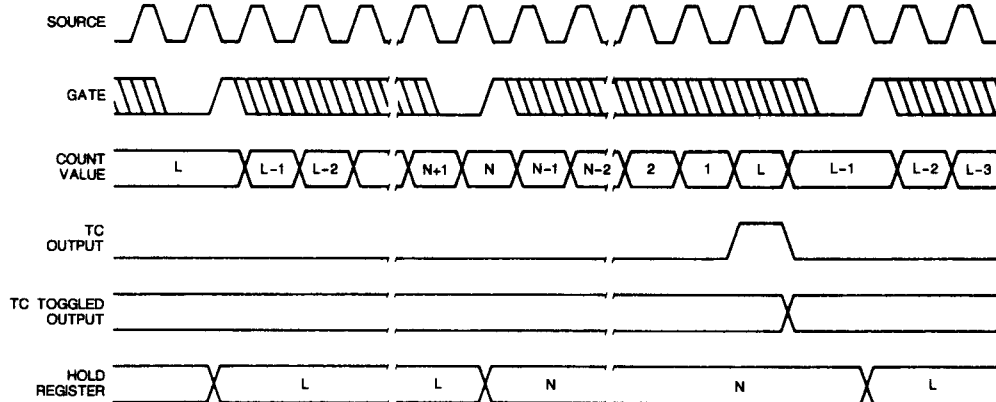

WF004773

Figure 15x. Mode X Waveforms

MODE X

Hardware Save (available in Am9513A only)

CM15	CM14	CM13	CM12	CM11	CM10	CM9	CM8
Edge			X	X	X	X	X

CM7	CM6	CM5	CM4	CM3	CM2	CM1	CM0
1	1	1	X	X	X	X	X

Mode X, as shown in Figure 15x, provides a hardware sampling of the counter contents without interrupting the count. A LOAD AND ARM command or a LOAD command followed by an ARM command is required to initialize the counter. Once armed, a Gate edge starts the counting operation; Gate edges applied to a disarmed counter are disregarded. After application of the Triggering Gate edge, the counter will count all qualified source edges until the first TC, irrespective of the gate level. All gate edges applied during the counting sequence will store the current count in the Hold register, but they will not interrupt the counting sequence. On each TC, the counter will be reloaded from the Load register and stopped. Subsequent counting requires a new triggering Gate edge; counting resumes on the first source edge following the triggering Gate edge.

Note: Mode X is only available in the Am9513A devices.

COUNTER MODE CONTROL OPTIONS

Each Counter Logic Group includes a 16-bit Counter Mode (CM) register used to control all of the individual options available with its associated general counter. These options include output configuration, count control, count source and gating control. Figure 16 shows the bit assignments for the Counter Mode registers. This section describes the control options in detail. Note that generally each counter is independently configured and does not depend on information outside its Counter Logic Group. The Counter Mode register should be loaded only when the counter is Disarmed. Attempts to load the Counter Mode register when the counter is armed may result in erratic counter operation.

After power-on reset or a Master Reset command, the Counter Mode registers are initialized to a preset condition. The value entered is 0B00 hex and results in the following control configuration:

- Output low-impedance to ground
- Count down
- Count binary
- Count once
- Load register selected
- No retrigging
- F1 input source selected
- Positive-true input polarity
- No gating

Output Control

Counter mode bits CM0 through CM2 specify the output control configuration. Figure 17 shows a schematic representation of the output control logic. The OUT pin may be off (a high-impedance state), or it may be inactive with a low-impedance to ground. The three remaining valid combinations represent the active-high, active-low or TC Toggle output waveforms.

One output form available is called Terminal Count (TC) and represents the period in time that the counter reaches an equivalent value of zero. TC will occur on the next count when the counter is at 0001 for down counting, at 9999 (BCD) for BCD up counting or at FFFF (hex) for binary up counting. Figure 18 shows a Terminal Count pulse and an example context that generated it. The TC width is determined by the period of the counting source. Regardless of any gating input or whether the counter is Armed or Disarmed, the terminal count will go active for only one clock cycle. Figure 18 assumes active-high source polarity, counter armed, counter decrementing and an external reload value of K.

The counter will always be loaded from an external location when TC occurs; the user can choose the source location and the value. If a non-zero value is picked, the counter will never really attain a zero state, and TC will indicate the counter state that would have been zero had no parallel transfer occurred.

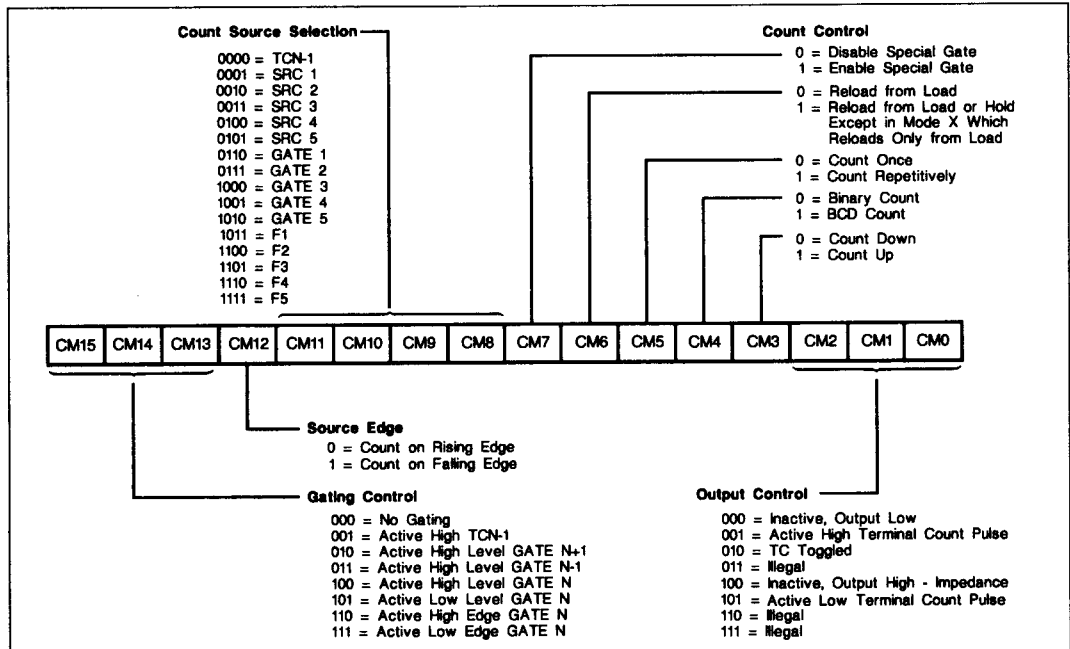

DF003784

Note: See Figure 15 for restrictions on Count Control and Gating Control bit combinations.

Figure 16. Counter Mode Register Bit Assignments

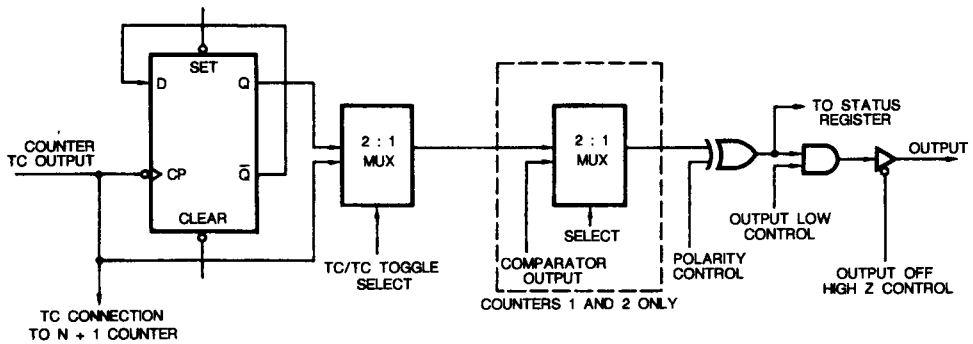

BD003393

Figure 17. Output Control Logic

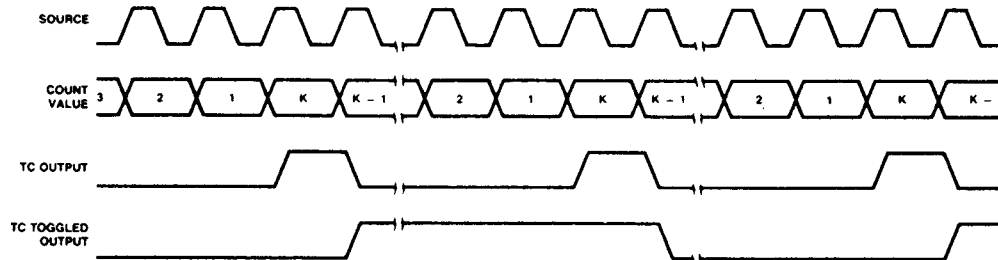

WF004780

Figure 18. Counter Output Waveforms

The other output form, TC Toggled, uses the trailing edge of TC to toggle a flip-flop to generate an output level instead of a pulse. The toggle output is half the frequency of TC. The TC Toggled output will frequently be used to generate variable duty-cycle square waves in Operating Modes G through K.

In Mode L the TC Toggled output can be used to generate a one-shot function, with the delay to the start of the output pulse and the width of the output pulse separately programmable. With selection of the minimum delay to the start of the pulse, the output will toggle on the second source pulse following application of the triggering Gate edge.

Note that the TC Toggled output form contains no implication about whether the output is active-high or active-low. Unlike the TC output, which generates a transient pulse which can clearly be active-high or active-low, the TC Toggled output waveform only flips the state of the output on each TC. The sole criterion of whether the TC Toggled output is active-high or active-low is the level of the output at the start of the count cycle. This can be controlled by the Set and Clear Output commands. (See Figure 19.)

TC (Terminal Count)

On each Terminal Count (TC), the counter will reload itself from the Load or Hold register. TC is defined as that period of time when the counter contents would have been zero had no reload occurred. Some special conditions apply to counter operation immediately before and during TC.

1. In the clock cycle before TC, an internal signal is generated that commits the counter to go to TC on the next count, and retriggering by a hardware Gate edge (Modes N, O, Q and R) or a software LOAD or LOAD AND ARM command will not extend the time to TC. Note that the "next count" driving the counter to TC can be caused by the application of a count source edge (in level gating modes, the edge must occur while the gate is active, or it will be disregarded), by the application of a LOAD or LOAD AND ARM command (see 2 below) or by the application of a STEP command.
2. If a LOAD or LOAD AND ARM command is executed during the cycle preceding TC, the counter will immediately go to TC. If these commands are issued during TC, the TC state will immediately terminate.
3. When TC is active, the counter will always count the next source edge issued to it, even if it is disarmed or gated off during TC. This means that TC will never be active for longer than one count period and it may, in fact, be shorter if a STEP command or a LOAD or LOAD AND ARM command is applied during TC (see item 2 above). This also means that a counter that is disarmed or stopped on TC is actually disarmed/stopped immediately following TC.

This may cause count sequences different from what a user might expect. Since the counter is always reloaded at the start of TC and since it always counts at the end of TC, the counter contents following TC will differ by one from the reloaded value, irrespective of the operating mode used.

If the reloaded value was 0001 for down counting, 9999 (BCD) for BCD up counting or FFFF (hex) for binary up counting, the count at the end of TC will drive the counter into TC again regardless of whether the counter is gated off or disarmed. As long as these values are reloaded, the TC output will stay active. If a TC Toggled output is selected, it will toggle on each count. Execution of a LOAD, LOAD AND ARM or STEP command with these counter contents will act the same as application of a source pulse, causing TC to remain active and a TC Toggled output to toggle.

Count Control

Counter Mode bits CM3 through CM7 specify the various options available for direct control of the counting process. CM3 and CM4 operate independently of the others and control up/down and BCD/binary counting. They may be combined freely with other control bits to form many types of counting configurations. The other three bits and the Gating Control field interact in complex ways. Bit CM5 controls the repetition of the count process. When CM5 = 1, counting will proceed in the specified mode until the counter is disarmed. When CM5 = 0, the count process will proceed only until one full cycle of operation occurs. This may occur after one or two TC events. The counter is then disarmed automatically. The single or double TC requirement will depend on the state of other control bits. Note that even if the counter is automatically disarmed upon a TC, it always counts the count source edge which generates the trailing TC edge.

When TC occurs, the counter is always reloaded with a value from either the Load register of the Hold register. Bit CM6 specifies the source options for reloading the counter. When CM6 = 0, the contents of the Load register will be transferred into the counter at every occurrence of TC. When CM6 = 1, the counter reload location will be either the Load or Hold Register. The reload location in this case may be controlled externally by using a Gate pin (Modes S and V) or may alternate on each TC (Modes G through L). With alternating sources and with the TC Toggled output selected, the duty cycle of the output waveform is controlled by the relative Load and Hold values and very fine resolution of duty cycles ratios may be achieved.

Bit CM7 controls the special gating functions that allow retriggering and the selection of Load or Hold sources for counter reloading. The use and definition of CM7 will depend

on the status of the Gating Control field and bits CM5 and CM6.

Hardware Retriggering

Whenever hardware retriggering is enabled (Modes N, O, Q, and R), all active-going Gate edges initiate retrigger operations. On application of the Gate edge, the counter contents will be transferred to the Hold register. On the first qualified source edge after application of the retriggering Gate edge, the Load register contents will be transferred into the counter. (Qualified source edges are edges which occur while the counter is gated on and Armed.)

This means that, if level gating is used, the edge occurring on active-going gate transitions will initiate a retrigger. Similarly, when edge gating is enabled, an edge used to start the counter will also initiate a retrigger. The first count source edge applied after the Gate edge will not increment/decrement the counter but retrigger it.

If a LOAD, LOAD AND ARM, or a STEP Command occurs between the retriggering Gate edge and the first qualified source edge, it will be interpreted as a source edge and transfer the Load register contents into the counter. Thereafter, the counter will count all qualified source edges.

When some form of Gating is specified, CM7 controls hardware retriggering. In this case, when CM7 = 0, hardware retriggering does not occur; when CM7 = 1, the counter is retrigged any time an active-going Gate edge occurs. Retriggering causes the counter value to be saved in the Hold register and the Load register contents to be transferred into the counter.

When No Gating is specified, the definition of CM7 changes. In this case, when CM7 = 0, the Gate input has no effect on the counting; when CM7 = 1, the Gate input specifies the source (selecting either the Load or Hold register) used to reload the counter when TC occurs. Figure 14 shows the various available control combinations for these interrelated bits.

Count Source Selection

Counter Mode bits CM8 through CM12 specify the source used as input to the counter and the active edge that is counted. Bit CM12 controls the polarity for all the sources; logic zero counts rising edges and logic one counts falling edges. Bits CM8 through CM11 select 1 of 16 counting sources to route to the counter input. Five of the available inputs are internal frequencies derived from the internal oscillator (see Figure 13 for frequency assignments). Ten of the available inputs are interface pins; five are labeled SRC and five are labeled GATE.

The 16th available input is the TC output from the adjacent lower-numbered counter. (The Counter 5 TC wraps around to the Counter 1 input.) This option allows internal concatenating that permits very long counts to be accumulated. Since all five counters may be concatenated, it is possible to configure a counter that is 80-bits long on one Am9513A chip. When TCN-1 is the source, the count ripples between the connected counters. External connections can also be made, and can use the toggle bit for even longer counts. This is easily accomplished by selecting a TC Toggled output mode and wiring OUTN to one of the SRC inputs.

Gating Control

Counter Mode bits CM15, CM14, CM13 specify the hardware gating options. When "no gating" is selected (000), the

counter will proceed unconditionally as long as it is armed. For any other gating mode, the count process is conditioned by the specified gating configuration.

For a code of 100 in this field, counting can proceed only when the pin labeled GATEN associated with Counter N is at a logic high level. When it goes LOW, counting is simply suspended until the Gate goes HIGH again. A code of 101 performs the same function with an opposite active polarity. Codes 010 and 011 offer the same function as 100, but specify alternate input pins as Gating Sources. This allows any of three interface pins to be used as gates for a given counter. On Counter 4, for example, pin 34, pin 35 or pin 36 may be used to perform the gating function. This also allows a single Gate pin to simultaneously control up to three counters. Counters 1 and 5 are considered adjacent when using TCN-1 (001), Gate N + 1 (010) and Gate N - 1 (011) controls.

For codes of 110 or 111 in this field, counting proceeds after the specified active Gate edge until one or two TC events occur. Within this interval, the Gate input is ignored, except for the retriggering option. When repetition is selected, a cycle will be repeated as soon as another Gate edge occurs. With repetition selected, any Gate edge applied after TC goes active will start a new count cycle. Edge gating is useful when implementing a digital single-shot since the gate can serve as a convenient firing trigger.

A 001 code in this field selects the TC (not TOGGLE) output from the adjacent lower-numbered counter as the gate. This is useful for synchronous counting when adjacent counters are concatenated.

COMMAND DESCRIPTIONS

The command set for the Am9513A allows the host processor to customize and manage the operating modes and features for particular applications, to initialize and update both the internal data and control information, and to manipulate operating bits during operation. Commands are entered directly into the 8-bit Command register by writing into the Control port (see Figure 6).

All available commands are described in the following text. Figure 19 summarizes the command codes and includes a brief description of each function. Figure 20 shows all the unused code combinations; unused codes should not be entered into the Command register since undefined activities may occur.

Six of the command types are used for direct software control of the counting process and they each contain a 5-bit S field. In a linear-select fashion, each bit in the S field corresponds to one of five general counters (S1 = Counter 1, S2 = Counter 2, etc.). When an S bit is a one, the specified operation is performed on the counter so designated; when an S bit is a zero, no operation occurs for the corresponding counter. This type of command format has three basic advantages. It saves host software by allowing any combination of counters to be acted on by a single command. It allows simultaneous action on multiple counters where synchronization of commands is important. It allows counter-specific service routines to control individual counters without needing to be aware of the operating context of other counters.

Three of the commands use a 3-bit binary code (N4, N2, N1) to identify the affected counter (a 001 programs counter 1, etc.). Unlike the previously mentioned commands, these commands allow you to program only one counter at a time.

Command Code								Command Description
C7	C6	C5	C4	C3	C2	C1	C0	
0	0	0	E2	E1	G4	G2	G1	Load Data Pointer register with contents of E and G fields. (G ≠ 000, G ≠ 110)
0	0	1	S5	S4	S3	S2	S1	Arm counting for all selected counters
0	1	0	S5	S4	S3	S2	S1	Load contents of specified source into all selected counters
0	1	1	S5	S4	S3	S2	S1	Load and Arm all selected counters*
1	0	0	S5	S4	S3	S2	S1	Disarm and Save all selected counters
1	0	1	S5	S4	S3	S2	S1	Save all selected counters in Hold register
1	1	0	S5	S4	S3	S2	S1	Disarm all selected counters
1	1	1	0	1	N4	N2	N1	Set Toggle out (HIGH) for counter N (001 ≤ N ≤ 101)
1	1	1	0	0	N4	N2	N1	Clear Toggle out (LOW) for counter N (001 ≤ N ≤ 101)
1	1	1	1	0	N4	N2	N1	Step counter N (001 ≤ N ≤ 101)
1	1	1	0	1	0	0	0	Set MM14 (Disable Data Pointer Sequencing)
1	1	1	0	1	1	1	0	Set MM12 (Gate off FOUT)
1	1	1	0	1	1	1	1	Set MM13 (Enter 16-bit bus mode)
1	1	1	0	0	0	0	0	Clear MM14 (Enable Data Pointer Sequencing)
1	1	1	0	0	1	1	0	Clear MM12 (Gate on FOUT)
1	1	1	0	0	1	1	1	Clear MM13 (Enter 8-bit bus mode)
1	1	1	1	1	0	0	0	Enable Prefetch for Write operations (Am9513'A' only)
1	1	1	1	1	0	0	1	Disable Prefetch for Write operations (Am9513'A' only)
1	1	1	1	1	1	1	1	Master reset

*Not to be used for asynchronous operations.

Figure 19. Am9513A Command Summary

C7	C6	C5	C4	C3	C2	C1	C0
1	1	1	1	0	0	0	0
1	1	1	1	0	1	1	0
1	1	1	1	0	1	1	1
0	0	0	X	X	1	1	0
0	0	0	X	X	0	0	0
*1	1	1	1	1	X	X	X

*Unused except when XXX = 111, 001 or 000.

Figure 20. Am9513A Unused Command Codes

Arm Counters

Coding:

C7	C6	C5	C4	C3	C2	C1	C0
0	0	1	S5	S4	S3	S2	S1

Description: Any combination of counters, as specified by the S field, will be enabled for counting. A counter must be armed before counting can commence. Once armed, the counting process may be further enabled or disabled using the hardware gating facilities. This command can only arm or do nothing for a given counter; a zero in the S field does not disarm the counter.

ARM and DISARM commands can be used to gate counter operation on and off under software control. DISARM commands entered while a counter is in the TC state will not take effect until the counter leaves TC. This ensures that the counter never latches up in a TC state. (The counter may leave the TC state because of application of a count source edge, execution of a LOAD or LOAD AND ARM command, or execution of a STEP command.)

In modes which alternate reload sources (Modes G-L), the ARMING operation is used as a reset for the logic which

determines which reload source to use on the upcoming TC. Following each ARM or LOAD AND ARM command, a counter in one of these modes will reload from the Hold register on the first TC and alternate reload sources thereafter (reload from the Load register on the second TC, the Hold register on the third, etc.).

Load Counters

Coding:

C7	C6	C5	C4	C3	C2	C1	C0
0	1	0	S5	S4	S3	S2	S1

Description: Any combination of counters, as specified in the S field, will be loaded with previously entered values. The source of information for each counter will be either the associated Load register or the associated Hold register, as determined by the operating configuration in the Mode register. The Load/Hold contents are not changed. This command will cause a transfer independent of any current operating configuration for the counter. It will often be used as a software retrigger or as counter initialization prior to active hardware gating.

If a LOAD or LOAD AND ARM command is executed during the cycle preceding TC, the counter will go immediately to TC. This occurs because the LOAD operation is performed by generating a pseudo-count pulse internal to the Am9513A, and the Am9513A is expecting to go into TC on the next count pulse. The reload source used to reload the counter will be the same as that which would have been used if the TC were generated by a source edge rather than by the LOAD operation.

Execution of a LOAD or LOAD AND ARM command while the counter is in TC will cause the TC to end. For Armed counters in all modes except S or V, the LOAD source used will be that to be used for the upcoming TC. (The LOADING operation will not alter the selection of reload source for the upcoming TC.) For Disarmed counters in modes except S or V, the reload sources used will be the LOAD register. For modes S or V, the reload source will be selected by the GATE input, regardless of whether the counter is Armed or Disarmed.

Special considerations apply when modes with alternating reload sources are used (Modes G – L). If a LOAD command drives the counter to TC in these modes, the reload source for the next TC will be from the opposite reload location. In other words, the LOAD-generated TC will cause the reload sources to alternate just as a TC generated by a source edge would. Note that if a second LOAD command is issued during the LOAD-generated TC (or during any other TC, for that matter), the second LOAD command will terminate the TC and cause a reload from the source designated for use with the next TC. The second LOAD will not alter the reload source for the next TC since the second LOAD does not generate a TC; reload sources alternate on TCs only, not on LOAD commands.

Load and Arm Counters*

Coding:

C7	C6	C5	C4	C3	C2	C1	C0
0	1	1	S5	S4	S3	S2	S1

Description: Any combination of counters, as specified in the S field, will be first loaded and then armed. This command is equivalent to issuing a LOAD command and then an ARM command.

A LOAD AND ARM command which drives a counter to TC generates the same sequence of operations as execution of a LOAD command and then an ARM command. In modes which disarm on TC (Modes A – C and N – O, and Modes G – I and S if the current TC is the second in the cycle), the ARM part of the LOAD AND ARM command will re-enable counting for another cycle. In modes which alternate reload sources (Modes G – L), the ARMing operation will cause the next TC to reload from the HOLD register, irrespective of which reload source the current TC used.

*This command should not be used during asynchronous operations.

Disarm Counters

Coding:

C7	C6	C5	C4	C3	C2	C1	C0
1	1	0	S5	S4	S3	S2	S1

Description: Any combination of counters, as specified by the S field, will be disabled from counting. A disarmed counter will cease all counting independent of other conditions. The only exception to this is that a counter in the TC state will always count once, in order to leave TC, before DISARMing. This count may be generated by a source edge, by a LOAD or LOAD AND ARM command (the LOAD AND ARM command will negate the DISARM command) or by a STEP command. A disarmed counter may be updated using the LOAD command and may be read using the SAVE command. A count process may be resumed using an ARM command. See the ARM command description for further details.

Save Counters

Coding:

C7	C6	C5	C4	C3	C2	C1	C0
1	0	1	S5	S4	S3	S2	S1

Description: Any combination of counters, as specified by S field, will have their contents transferred into their associated Hold register. The transfer takes place without interfering with any counting that may be underway. This command will overwrite any previous Hold register contents. The SAVE command is designed to allow an accumulated count to be preserved so that it can be read by the host CPU at some later time.

Disarm and Save Counters

Coding:

C7	C6	C5	C4	C3	C2	C1	C0
1	0	0	S5	S4	S3	S2	S1

Description: Any combination of counters, as specified by the S field, will be disarmed, and the contents of the counter will be transferred into the associated Hold registers. This command is identical to issuing a DISARM command followed by a SAVE command.

Set TC Toggle Output

Coding:

C7	C6	C5	C4	C3	C2	C1	C0
1	1	1	0	1	N4	N2	N1

(001 ≤ N ≤ 101)

Description: The initial output level for TC Toggle mode is set (HIGH) for counter N selected by N4, N2, N1 = 001 (Counter 1) thru 101 (Counter 5) respectively. This command conditions the TC Toggle flip-flop (see Figure 17) but does not appear at the counter output unless TC Toggle mode (CM2, CM1, CM0 = 010) is selected.

Clear TC Toggle Output

Coding:

C7	C6	C5	C4	C3	C2	C1	C0
1	1	1	0	0	N4	N2	N1

(001 ≤ N ≤ 101)

Description: The initial output level for TC Toggle mode is Cleared (LOW) for counter N selected by N4, N2, N1 = 001 (Counter 1) thru 101 (Counter 5) respectively. This command conditions the TC Toggle flip-flop (see Figure 17) but does not appear at the counter output unless TC Toggle mode (CM2, CM1, CM0 = 010) is selected.

Step Counter

Coding:

C7	C6	C5	C4	C3	C2	C1	C0
1	1	1	1	0	N4	N2	N1

(001 ≤ N ≤ 101)

Description: Counter N is incremented or decremented by one, depending on its operating configuration. If the Counter Mode register associated with the selected counter has its CM3 bit cleared to zero, this command will cause the counter to decrement by one. If CM3 is set to a logic high, this command will increment the counter by one. The STEP command will take effect even on a disarmed counter.

Load Data Pointer Register

Coding:

C7	C6	C5	C4	C3	C2	C1	C0
0	0	0	E2	E1	G4	G2	G1

(G4, G2, G1 ≠ 000, ≠ 110)

Description: Bits in the E and G fields will be transferred into the corresponding Element and Group fields of the Data Pointer register as shown in Figure 7. The Byte Pointer bit in the Data Pointer register is set. Transfers into the Data Pointer only occur for G field values of 001, 010, 011, 100, 101 and 111. Values of 000 and 110 for G should not be used. See the "Setting the Data Pointer Register" section of this document for additional details.

Disable Data Pointer Sequencing

Coding:

C7	C6	C5	C4	C3	C2	C1	C0
1	1	1	0	1	0	0	0

Description: This command sets Master Mode bit 14 without affecting other bits in the Master Mode register. MM14 controls the automatic sequencing of the Data Pointer register. Disabling the sequencing allows repetitive host processor access to a given internal location without repetitive updating of the Data Pointer. MM14 may also be controlled by loading a full word into the Master Mode register.



Enable Data Pointer Sequencing

Coding:

C7	C6	C5	C4	C3	C2	C1	C0
1	1	1	0	0	0	0	0

Description: This command clears Master Mode bit 14 without affecting other bits in the Master Mode register. MM14 controls the automatic sequencing of the Data Pointer register. Enabling the sequencing allows sequential host processor access to several internal locations without repetitive updating of the Data Pointer. MM14 may also be controlled by loading a full word into the Master Mode register. See the "Data Pointer Register" section of this document for additional information on Data Pointer sequencing

Enable 16-Bit Data Bus

Coding:

C7	C6	C5	C4	C3	C2	C1	C0
1	1	1	0	1	1	1	1

Description: This command sets Master Mode bit 13 without affecting other bits in the Master Mode register. MM13 controls the multiplexer in the data bus buffer. When MM13 is set, no multiplexing takes place and all 16 external data bus lines are used to transfer information into and out of the STC. MM13 may also be controlled by loading the full Master Mode register in parallel.

Enable 8-Bit Data Bus

Coding:

C7	C6	C5	C4	C3	C2	C1	C0
1	1	1	0	0	1	1	1

Description: This command clears Master Mode bit 13 without affecting other bits in the Master Mode register. MM13 controls the multiplexer in the data bus buffer. When MM13 is cleared, the multiplexer is enabled and 16-bit internal information is transferred eight bits at a time to the eight low-order external data bus lines. MM13 may also be controlled by loading the full Master Mode register in parallel.

Gate Off FOUT

Coding:

C7	C6	C5	C4	C3	C2	C1	C0
1	1	1	0	1	1	1	0

Description: This command sets Master Mode bit 12 without affecting other bits in the Master Mode register. MM12 controls the output state of the FOUT signal. When gated off, the FOUT line will exhibit a low-impedance to ground. MM12 may also be controlled by loading the full Master Mode register in parallel.

Gate On FOUT

Coding:

C7	C6	C5	C4	C3	C2	C1	C0
1	1	1	0	0	1	1	0

Description: This command clears Master Mode bit 12 without affecting other bits in the Master Mode register. MM12 controls the output status of the FOUT signal. When MM12 is

cleared, FOUT will become active and will drive out the selected and divided FOUT signal. MM12 may also be controlled by loading the full Master Mode register in parallel. When FOUT is gated on or off, a transient pulse may be generated on the FOUT signal.

Disable Prefetch for Write Operations

Coding:

C7	C6	C5	C4	C3	C2	C1	C0
1	1	1	1	1	0	0	1

Description: This command disables the prefetch circuitry during Write operations (if does not affect Read operations). This reduces the write recovery time and allows the user to use block move instructions for initialization of the Am9513A registers. Once prefetch is disabled for writing, an Enable Prefetch for Write or a Reset command is necessary to re-enable the prefetch circuitry for writing.

Note: This command is only available in Am9513A devices; it is an illegal command in the "non-A" Am9513 device.

Enable Prefetch for Write Operations

Coding:

C7	C6	C5	C4	C3	C2	C1	C0
1	1	1	1	1	0	0	0

Description: This command re-enables the prefetch circuitry for Write operations. It is used only to terminate the Disable Prefetch Command.

Note: This command is only available in Am9513A devices; it is an illegal command in the "non-A" Am9513 device.

Master Reset

Coding:

C7	C6	C5	C4	C3	C2	C1	C0
1	1	1	1	1	1	1	1

Description: The Master Reset command duplicates the action of the power-on reset circuitry. It disarms all counters, enters 0000 in the Master Mode, Load and Hold registers and enters 0B00 (hex) in the Counter Mode registers.

Following either a power-up or software reset, the LOAD command should be applied to all the counters to clear any that may be in a TC state. The Data Pointer register should also be set to a legal value, since reset does not initialize it. A complete reset operation follows.

1. Using the procedure given in the "Command Initiation" section of this document, enter the FF (hex) command to perform a software reset.
2. Using the "Command Initiation" procedure, enter the LOAD command for all counters, opcode 5F (hex).
3. Using the procedure given in the "Setting the Data Pointer Register" section of this document, set the Data Pointer to a valid code. The legal Data Pointer codes are given in Figure 8.

The Master Mode, Counter Mode, Load and Hold registers can now be initialized to the desired values.

ABSOLUTE MAXIMUM RATINGS

Storage Temperature -65°C to +150°C
 VCC with Respect to VSS -0.5 V to +7.0 V
 All Signal Voltages
 with Respect to VSS -0.5 V to +7.0 V
 Power Dissipation (Package Limitation) 1.5 W

Stresses above those listed under ABSOLUTE MAXIMUM RATINGS may cause permanent device failure. Functionality at or above these limits is not implied. Exposure to absolute maximum ratings for extended periods may affect device reliability.

OPERATING RANGES

Commercial (C) Devices
 Temperature (T_A) 0 to +70°C
 Supply Voltage (V_{CC}) 5 V ±5%

Industrial (I) Devices
 Temperature (T_A) -40 to +85°C
 Supply Voltage (V_{CC}) 5 V ±5%

Military (M) Devices
 Temperature (T_C) -55 to +125°C
 Supply Voltage (V_{CC}) 5 V ±5%

Operating ranges define those limits between which the functionality of the device is guaranteed.

DC CHARACTERISTICS over operating ranges unless otherwise specified:

Parameters	Description		Test Conditions	Min	Max	Units
VIL	Input Low Voltage	All Inputs Except X2		VSS - 0.5	0.8	Volts
		X2 Input		VSS - 0.5	0.8	
VIH	Input High Voltage	All Input Except X2		2.2 V	VCC	Volts
		X2 Input		3.8	VCC	
VITH	Input Hysteresis (SRC and GATE Inputs Only)			0.2		Volts
VOL	Output Low Voltage		IOL = 3.2 mA		0.4	Volts
VOH	Output High Voltage		IOH = -200 μA	2.4		Volts
IIX	Input Load Current (Except X2)		VSS ≤ VIN ≤ VCC		±10	μA
IIX	Input Load Current X2		VSS ≤ VIN ≤ VCC		±100	μA
IOZ	Output Leakage Current (Except X1)		VSS + 0.4 ≤ VOUT ≤ VCC High-Impedance State		±25	μA
ICC	VCC Supply Current (Steady State)				255 275	mA
CIN	Input Capacitance		f = 1 MHz, T _A = +25°C, All pins not under test at 0 V.	10*	20*	pF
COUT	Output Capacitance			15*	20*	
CIO	IN/OUT Capacitance			20*	20*	

* Guaranteed by design.

SWITCHING TEST INPUT/OUTPUT WAVEFORMS

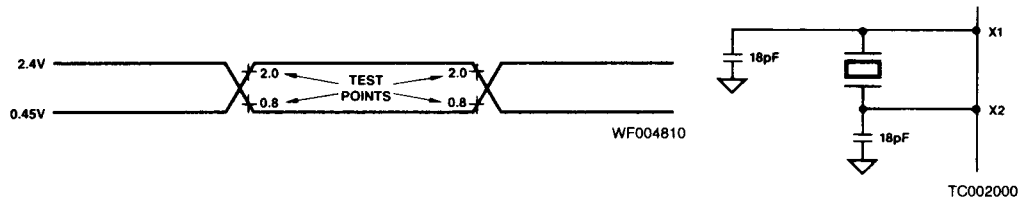

Crystal is fundamental mode parallel resonant 32 pF load capacitance less than 100 Ω ESR C₀ less than 100 pF.

2

The second and fourth letters designate the reference states of the signals named in the first and third letters respectively, using the following abbreviations.

H = HIGH
L = LOW
V = VALID
X = Unknown or Don't care
Z = High-Impedance

2. Any input transition that occurs before this minimum setup requirement will be reflected in the contents read from the status register.
3. Any input transition that occurs before this minimum setup requirement will act on the counter before the execution of the operation initiated by the write and the counter may be off by one count.
4. Any input transition that occurs after this minimum hold time is guaranteed to not influence the contents read from the status register on the current read operation.
5. Any input transition that occurs after this minimum hold time is guaranteed to be seen by the counter as occurring after the action initiated by the write operation and the counter may be off by one count.
6. This parameter applies to cases where the write operation causes a change in the output bit.
7. The enabled count source is one of F1 – F5, TCN-1 SRC1 – SRC5 or GATE1 – GATE 5, as selected in the applicable Counter Mode register. The timing diagram assumes the counter counts on rising source edges. The timing specifications are the same for falling-edge counting.
8. This parameter applies to edge gating (CM15 – CM13 = 110 or 111) and gating when both CM7 = 1 and CM15 – CM13 ≠ 000. This parameter represents the minimum GATE pulse width needed to ensure that the pulse initiates counting or counter reloading.
9. This parameter applies to both edge and level gating (CM15 – CM13 = 001 through 111 and CM7 = 0). This pa-

rameter represents the minimum setup or hold times to ensure that the Gate input is seen at the intended level on the active source edge and the counter may be off by one count.

10. This parameter assumes that the GATENA input is unused (16-bit bus mode) or is tied high. In cases where the GATENA input is used, this timing specification must be met by both the GATE and GATENA inputs.
11. Signals F1 – F5 cannot be directly monitored by the user. The phase difference between these signals will manifest itself by causing counters using two different F signals to count at different times on nominally simultaneous transitions in the F signals. F1 = X2.
12. This timing specification assumes that \overline{CS} is active whenever \overline{RD} or \overline{WR} are active. \overline{CS} may be held active indefinitely.
13. This parameter assumes X2 is driven from an external gate with a square wave.
14. This parameter assumes that the write operation is to the command register.
15. This timing specification applies to single-action commands only (e.g., LOAD, ARM, SAVE, etc.). For double-action commands such as LOAD AND ARM and DISARM AND SAVE, TWHHL minimum = 700 ns.
16. In short data write mode, TWHRL and TWHWL minimum = 1000 ns.
17. This parameter applies to the hardware retrigger/save modes N, O, Q, R, and X (CM7 = 1 and CM15 – CM13 < > 000). This parameter ensures that the gating pulse initiates a hardware retrigger/save operation.
18. This parameter applies to hardware load source select modes S and V (CM7 = 1 and CM15 – CM13 = 000). This parameter represents the minimum hold time to ensure that the GATE input selects the correct load source on the active source edge.

SWITCHING CHARACTERISTICS over **COMMERCIAL** operating ranges unless otherwise specified (Note 1)

Parameters	Description	Figure	Am9513A		Unit	
			Min	Max		
TAVRL	C/D Valid to Read Low	21	25		ns	
TAVWH	C/D Valid to Write High	21	170		ns	
TCHCH	X2 High to X2 High (X2 Period) (Note 13)	22	145		ns	
TCHCL	X2 High to X2 Low (X2 High Pulse Width) (Note 13)	22	70		ns	
TCLCH	X2 Low to X2 High (X2 Low Pulse Width) (Note 13)	22	70		ns	
TDVWH	Data In Valid to Write High	21	80		ns	
TEHEH	Count Source High to Count Source High (Source Cycle Time) (Note 7)	22	145		ns	
TEHEL	Count Source Pulse Duration (Note 7)	22	70		ns	
TELEH						
TEHFV	Count Source High to FOUT Valid (Note 7)	22		500	ns	
TEHGV	Count Source High to Gate Valid (Level Gating Hold Time) (Notes 7, 9, 10)	22	10		ns	
TEHRL	Count Source High to Read Low (Set-up Time) (Notes 2, 7)	21	190		ns	
TEHWH	Count Source High to Write High (Set-up Time) (Notes 3, 7)	21	-100		ns	
TEHYV	Count Source High to Out Valid (Note 7)	22		300	ns	
						TC Output
						Immediate or Delayed Toggle Output
	Comparator Output	22		350		
TFN	FN High to FN + 1 Valid (Note 11)	22		75	ns	
TGVEH	Gate Valid to Count Source High (Level Gating Set-up Time) (Notes 7, 9, 10)	22	100		ns	
TGVG	Gate Valid to Gate Valid (Gate Pulse Duration) (Notes 8, 10)	22	145		ns	
TGVVH	Gate Valid to Write High (Notes 3, 10)	21	-100		ns	
TRHAX	Read High to C/D Don't Care	21	0		ns	
TRHEH	Read High to Count Source High (Notes 4, 7)	21	0		ns	
TRHQX	Read High to Data Out Invalid	21	10		ns	
TRHQZ	Read High to Data Out at High-Impedance (Data Bus Release Time)	21		85	ns	
TRHRL	Read High to Read Low (Read Recovery Time)	21	1000		ns	
TRHSH	Read High to CS High (Note 12)	21	0		ns	
TRHWL	Read High to Write Low (Read Recovery Time)	21	1000		ns	
TRLQV	Read Low to Data Out Valid	21		110	ns	
TRLQX	Read Low to Data Bus Driven (Data Bus Drive Time)	21	20		ns	
TRLRH	Read Low to Read High (Read Pulse Duration) (Note 12)	21	160		ns	
TSLRL	CS Low to Read Low (Note 12)	21	20		ns	
TSLWH	CS Low to Write High (Note 12)	21	170		ns	
TWHAX	Write High to C/D Don't Care	21	20		ns	
TWHDX	Write High to Data In Don't Care	21	20		ns	
TWHEH	Write High to Count Source High (Notes 5, 7, 14, 15)	21	550		ns	
TWHGV	Write High to Gate Valid (Notes 5, 10, 14)	21	475		ns	
TWHRL	Write High to Read Low (Write Recovery Time) (Note 16)	21	1500*		ns	
TWHSH	Write High to CS High (Note 12)	21	20		ns	
TWHWL	Write High to Write Low (Write Recovery Time) (Note 16)	21	1500*		ns	
TWHYV	Write High to Out Valid (Notes 6, 14)	21		650	ns	
TWLWH	Write Low to Write High (Write Pulse Duration) (Note 12)	21	150		ns	
TGVEH2	Gate Valid to Count Source High (Special Gate) (Notes 10, 13, 17)	22	200		ns	
TEHGV2	Count Source High to Gate Valid (Special Gate) (Notes 10, 13, 18)	22	80		ns	

Notes:

1. Abbreviations used for the switching parameter symbols are given as the letter T followed by four or five characters. The first and third characters represent the signal names on which the measurements start and end. Signal abbreviations used are:

- A (Address) = C/D
- C (Clock) = X2
- D (Data In) = DB0-DB15

- E (Enabled counter source input) = SRC1 - SRC5, GATE1 - GATE5, F1 - F5, TCN-1
- F = FOUT
- G (Counter gate input) = GATE1 - GATE5, TCN-1
- Q (Data Out) = DB0 - DB15
- R (Read) = \overline{RD}
- S (Chip Select) = \overline{CS}
- W (Write) = \overline{WR}
- Y (Output) = OUT1 - OUT5

SWITCHING CHARACTERISTICS over **MILITARY** operating range (for SMD/DESC and APL Products, Group A, Subgroups 9, 10, 11 are tested unless otherwise noted)

Parameter Symbol	Description	Am9513A		Unit
		Min.	Max.	
TAVRL	C/ \bar{D} Valid to Read Low	25		ns
TAVWH	C/ \bar{D} Valid to Write High	170		ns
TCHCH	X2 High to X2 High (X2 Period) (Note 13)	145		ns
TCHCL	X2 High to X2 Low (X2 High Pulse Width) (Note 13)	70		ns
TCLCH	X2 Low to X2 High (X2 Low Pulse Width) (Note 13)	70		ns
TDVWH	Data In Valid to Write High	80		ns
TEHEH	Count Source High to Count Source High (Source Cycle Time) (Note 7)	145		ns
TEHEL TELEH	Count Source Pulse Duration (Note 7)	70		ns
TEHVV	Count Source High to FOUT Valid (Note 7)		500	ns
TEHGV	Count Source High to Gate Valid (Level Gating Hold Time) (Notes 7, 9, 10)	10		ns
TEHRL	Count Source High to Read Low (Set-up Time) (Notes 2, 7)	190		ns
TEHWH	Count Source High to Write High (Set-up Time) (Notes 3, 7)	-100		ns
TEHYV	Count Source High to Out Valid (Note 7)	TC Output	300	ns
		Immediate or Delayed Toggle Output	300	
		Comparator Output	350	
TFN	FN High to FN + 1 Valid (Note 11)		75	ns
TGVEH	Gate Valid to Count Source High (Level Gating Set-up Time) (Notes 7, 9, 10)	100		ns
TGGVV	Gate Valid to Gate Valid (Gate Pulse Duration) (Notes 8, 10)	145		ns
TGVWH	Gate Valid to Write High (Notes 3, 10)	-100		ns
TRHAX	Read High to C/ \bar{D} Don't Care	0		ns
TRHEH	Read High to Count Source High (Notes 4, 7)	0		ns
TRHQX	Read High to Data Out Invalid	10		ns
TRHQZ	Read High to Data Out at High-Impedance (Data Bus Release Time)		85	ns
TRHRL	Read High to Read Low (Read Recovery Time)	1000		ns
TRHSH	Read High to \bar{CS} High (Note 12)	0		ns
TRHWL	Read High to Write Low (Read Recovery Time)	1000		ns
TRLQV	Read Low to Data Out Valid		110	ns
TRLQX	Read Low to Data Bus Driven (Data Bus Drive Time)	20		ns
TLRLH	Read Low to Read High (Read Pulse Duration) (Note 12)	160		ns
TSLRL	\bar{CS} Low to Read Low (Note 12)	20		ns
TSLWH	\bar{CS} Low to Write High (Note 12)	170		ns
TWHAX	Write High to C/ \bar{D} Don't Care	20		ns
TWHDX	Write High to Data In Don't Care	20		ns
TWHEH	Write High to Count Source High (Notes 5, 7, 14, 15)	550		ns
TWHGV	Write High to Gate Valid (Notes 5, 10, 14)	475		ns
TWHRL	Write High to Read Low (Write Recovery Time) (Note 16)	1500		ns
TWHSH	Write High to \bar{CS} High (Note 12)	20		ns
TWHWL	Write High to Write Low (Write Recovery Time) (Note 16)	1500		ns
TWHYV	Write High to Out Valid (Notes 6, 14)		650	ns
TWLWH	Write Low to Write High (Write Pulse Duration) (Note 12)	150		ns
TGVEH2	Gate Valid to Count Source High (Special Gate) (Notes 10, 13, 17)	200		ns
TEHGV2	Count Source High to Gate Valid (Special Gate) (Notes 10, 13, 18)	80		ns

Notes:

1. Abbreviations used for the switching parameter symbols are given as the letter T followed by four or five characters. The first and third characters represent the signal names on which the measurements start and end. Signal abbreviations used are:

- A (Address) = C/ \bar{D}
- C (Clock) = X2
- D (Data In) = DB0 - DB15

- E (Enabled counter source input) = SRC1 - SRC5, GATE1 - GATE5, F1 - F5, TCN-1
- F = FOUT
- G (Counter gate input) = GATE1 - GATE5, TCN-1
- Q (Data Out) = DB0 - DB15
- R (Read) = \bar{RD}
- S (Chip Select) = \bar{CS}
- W (Write) = \bar{WR}
- Y (Output) = OUT1 - OUT5

The second and fourth letters designate the reference states of the signals named in the first and third letters respectively, using the following abbreviations.

- H = HIGH
- L = LOW
- V = VALID
- X = Unknown or Don't care
- Z = High-Impedance

2. Any input transition that occurs before this minimum setup requirement will be reflected in the contents read from the status register.
3. Any input transition that occurs before this minimum setup requirement will act on the counter before the execution of the operation initiated by the write and the counter may be off by one count.
4. Any input transition that occurs after this minimum hold time is guaranteed to not influence the contents read from the status register on the current read operation.
5. Any input transition that occurs after this minimum hold time is guaranteed to be seen by the counter as occurring after the action initiated by the write operation and the counter may be off by one count.
6. This parameter applies to cases where the write operation causes a change in the output bit.
7. The enabled count source is one of F1-F5, TCN-1 SRC1-SRC5 or GATE1-GATE 5, as selected in the applicable Counter Mode register. The timing diagram assumes the counter counts on rising source edges. The timing specifications are the same for falling-edge counting.
8. This parameter applies to edge gating (CM15 - CM13 = 110 or 111) and gating when both CM7 = 1 and CM15 - CM13 ≠ 000. This parameter represents the minimum GATE pulse width needed to ensure that the pulse initiates counting or counter reloading.
9. This parameter applies to both edge and level gating (CM15 - CM13 = 001 through 111 and CM7 = 0). This pa-

parameter represents the minimum setup or hold times to ensure that the Gate input is seen at the intended level on the active source edge and the counter may be off by one count.

10. This parameter assumes that the GATENA input is unused (16-bit bus mode) or is tied high. In cases where the GATENA input is used, this timing specification must be met by both the GATE and GATENA inputs.
11. Signals F1 - F5 cannot be directly monitored by the user. The phase difference between these signals will manifest itself by causing counters using two different F signals to count at different times on nominally simultaneous transitions in the F signals. F1 = X2.
12. This timing specification assumes that \overline{CS} is active whenever \overline{RD} or \overline{WR} are active. \overline{CS} may be held active indefinitely.
13. This parameter assumes X2 is driven from an external gate with a square wave.
14. This parameter assumes that the write operation is to the command register.
15. This timing specification applies to single-action commands only (e.g., LOAD, ARM, SAVE, etc.). For double-action commands such as LOAD AND ARM and DISARM AND SAVE, TWHEH minimum = 700 ns.
16. In short data write mode, TWHRL and TWHWL minimum = 1000 ns.
17. This parameter applies to the hardware retrigger/save modes N, O, Q, R, and X (CM7 = 1 and CM15 - CM13 < > 000). This parameter ensures that the gating pulse initiates a hardware retrigger/save operation.
18. This parameter applies to hardware load source select modes S and V (CM7 = 1 and CM15 - CM13 = 000). This parameter represents the minimum hold time to ensure that the GATE input selects the correct load source on the active source edge.

SWITCHING TEST CIRCUIT

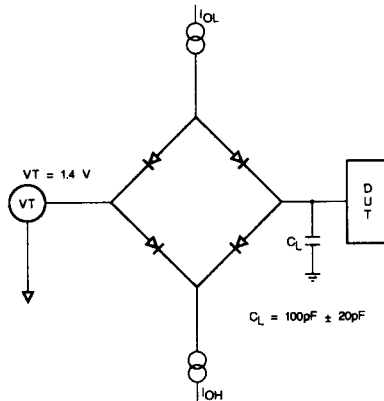

TC003853

This test circuit is the dynamic load of a Teradyne J941.

SWITCHING WAVEFORMS

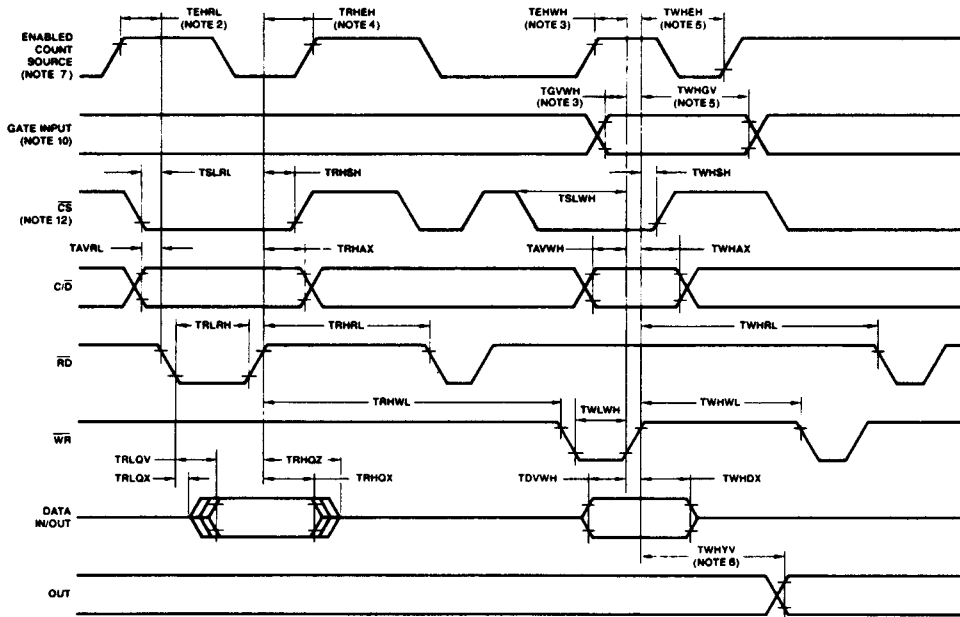

WF004792

Figure 21. Bus Transfer Switching Waveforms

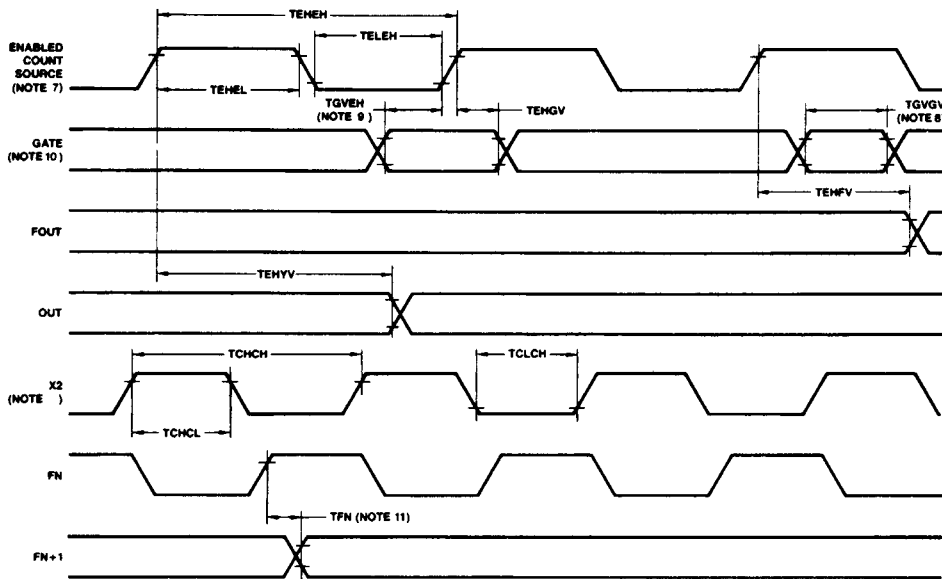

WF004801

Figure 22. Counter Switching Waveforms

APPENDIX A

Design Hints

- 1) When a crystal is not being used, X1 and X2 should be connected as shown for TTL input (Figure A1) and no input (Figure A2).
- 2) Recommended oscillator capacitor values are 18 pF on X1 and X2.
- 3) Unused inputs should be tied to VCC.
- 4) The TC output can glitch when the counter is loaded. For this reason this output should not be connected to edge sensitive interrupts. The counter output should be set or cleared after the LOAD command.
5. The two most significant bits of the status register are not specified. They may be zero or one.
6. The mode register should not be modified when the counter is armed.
7. The LOAD and HOLD registers should not be changed during TC.
8. When using the different clocks for different counters be aware that there is a 75 ns skew between F1, F2, F3, F4 and F5.
9. The TC output will remain inactive if programmed to be in the TC TOGGLE mode and the step command is used to increment or decrement the counter. The output will go into TC if programmed to be in the active High or active Low terminal count modes. The only two ways out of TC in this case are:
 - Arming the counter and having an active source connected to it.
 - Issuing another step command.
- 10) Timing parameters TEHWH and TGVWH are specified as negative. The diagrams in Figure A3 show the relationship between these signals.
- 11) In mode X the counter will count all qualified source edges until the second (not the first) TC and then stop.
- 12) A TC can occur when the counters are loaded if the counter was stopped at FFFF_H or 9999₁₀ in the count up mode or at count 0001 when counting down. This is because an internal TC is generated which forces TC to be generated on the next count pulse.
- 13) In modes that alternate the reload source between the load and the hold registers (e.g., mode J), if the counter is disarmed at 0001_H for down counting or 9999₁₀ for BCD up counting or FFFF_H for binary up counting and rearmed, the reload source after the first TC will be the load register instead of the hold register. To avoid this, issue a software "dummy" load to the counter immediately after the disarm command.
- 14) In the down counting mode of the Am9513A, if a 0001 is loaded into the counter and another LOAD COUNTER command is issued, the TC of that counter will go active. If the load register contents are subsequently changed, and the counter armed, the first clock edge will cause the new load register contents to transfer into the counter and the next clock edge will decrement the counter and make it go out of TC.
- 15) Glitches on \overline{CS} just before the \overline{RD} or \overline{WR} pulse may cause the part to behave incorrectly.
- 16) Timing parameters TGVEH & TEHGV must not be violated; Figure A4 shows a method.

Troubleshooting (Symptom: Solution)

- 1) Registers not being programmed correctly: Check READ or WRITE recovery time.
- 2) Setup and hold problems observed in synchronous systems: Try switching from positive edge to negative edge triggering.

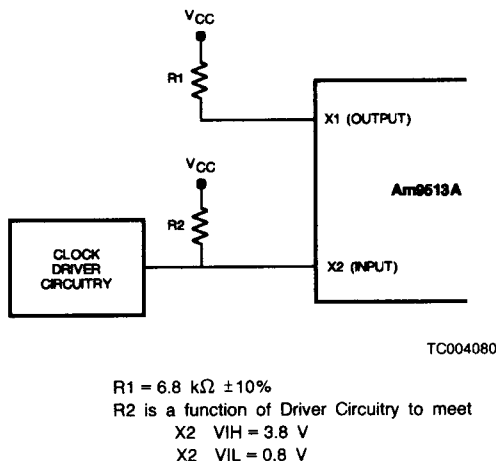

Figure A1. Crystal Input Configuration

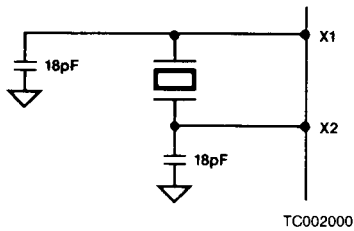

Figure A2. Crystal Input Configuration

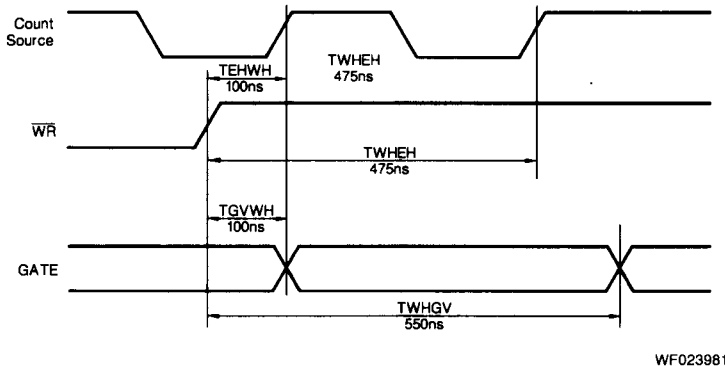

Figure A3. TEHWH/TGVWH Timing Diagram

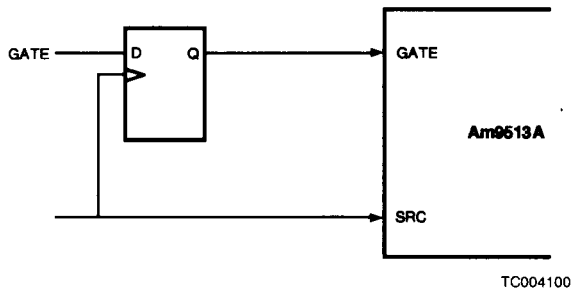

Figure A4. GATE/SRC Configuration Suggestion