

HiRel K-Band GaAs Super Low Noise HEMT

- **HiRel Discrete and Microwave Semiconductor**
- Conventional AlGaAs/GaAs HEMT
(For new design we recommend to use our pseudo-morphic HEMT CFY67)
- For professional super low-noise amplifiers
- For frequencies from 500 MHz to > 20 GHz
- Hermetically sealed microwave package
- Super low noise figure, high associated gain
-  **ESA Space Qualified**
ESA/SCC Detail Spec. No.: 5613/002,
Type Variant No.s 01 to 04

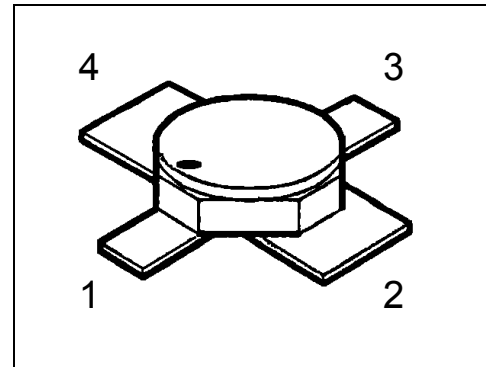

ESD: Electrostatic discharge sensitive device, observe handling precautions!

Type	Marking	Ordering Code	Pin Configuration				Package
			1	2	3	4	
CFY66-08 (ql)	-	see below	G	S	D	S	Micro-X
CFY66-08P (ql)							
CFY66-10 (ql)							
CFY66-10P (ql)							

CFY66-nnl: specifies gain and output power levels (see electrical characteristics)

(ql) Quality Level:	P: Professional Quality,	Ordering Code:	on request
	H: High Rel Quality,	Ordering Code:	on request
	S: Space Quality,	Ordering Code:	on request
	ES: ESA Space Quality,	Ordering Code:	on request

(see order instructions for ordering example)

Maximum Ratings

Parameter	Symbol	Values	Unit
Drain-source voltage	V_{DS}	3.5	V
Drain-gate voltage	V_{DG}	4.5	V
Gate-source voltage (reverse / forward)	V_{GS}	- 3... + 0.5	V
Drain current	I_D	60	mA
Gate forward current	I_G	2	mA
RF Input Power, C- and X-Band ¹⁾	$P_{RF,in}$	+ 10	dBm
Junction temperature	T_J	150	°C
Storage temperature range	T_{stg}	- 65... + 150	°C
Total power dissipation ²⁾	P_{tot}	200	mW
Soldering temperature ³⁾	T_{sol}	230	°C

Thermal Resistance

Junction-soldering point	$R_{th,JS}$	≤ 515 (tbc.)	K/W
--------------------------	-------------	--------------	-----

Notes.:

- 1) For $V_{DS} \leq 2$ V. For $V_{DS} > 2$ V, derating is required.
- 2) At $T_s = + 47$ °C. For $T_s > + 47$ °C derating is required.
- 3) During 15 sec. maximum. The same terminal shall not be resoldered until 3 minutes have elapsed.

Electrical Characteristics (at $T_A=25^{\circ}\text{C}$; unless otherwise specified)

Parameter	Symbol	Values			Unit
		min.	typ.	max.	
DC Characteristics					
Drain-source saturation current $V_{DS} = 2\text{ V}, V_{GS} = 0\text{ V}$	I_{DSS}	10	30	60	mA
Gate threshold voltage $V_{DS} = 2\text{ V}, I_D = 1\text{ mA}$	$-V_{Gth}$	0.2	0.7	2.0	V
Drain current at pinch-off $V_{DS} = 1.5\text{ V}, V_{GS} = -3\text{ V}$	I_{Dp}	-	< 50	-	μA
Gate leakage current at pinch-off $V_{DS} = 1.5\text{ V}, V_{GS} = -3\text{ V}$	$-I_{Gp}$	-	< 50	200	μA
Transconductance $V_{DS} = 2\text{ V}, I_D = 10\text{ mA}$	g_{m10}	40	55	-	mS
Gate leakage current at operation $V_{DS} = 2\text{ V}, I_D = 10\text{ mA}$	$-I_{G10}$	-	< 0.5	2	μA
Thermal resistance junction to soldering point	R_{thJS}	-	450	-	K/W

Electrical Characteristics (continued)

Parameter	Symbol	Values			Unit
		min.	typ.	max.	
AC Characteristics					
Noise figure ¹⁾ $V_{DS} = 2 \text{ V}$, $I_D = 10 \text{ mA}$, $f = 12 \text{ GHz}$ CFY66-08, -08P CFY66-10, 10P	NF	-	0.7	0.8	dB
Associated gain. ¹⁾ $V_{DS} = 2 \text{ V}$, $I_D = 10 \text{ mA}$, $f = 12 \text{ GHz}$ CFY66-08, -08P CFY66-10, 10P	G_a	10.0	11.0	-	dB
Output power at 1 dB gain compression ²⁾ $V_{DS} = 2 \text{ V}$, $I_D = 20 \text{ mA}$, $f = 12 \text{ GHz}$ CFY66-06, -08, -10 CFY66-08P, -10P	P_{1dB}	10.0	11.0	-	dBm

Notes.:

1) Noise figure / associated gain characteristics given for minimum noise figure matching conditions (fixed generic matching, no fine-tuning).

2) Output power characteristics given for optimum output power matching conditions (fixed generic matching, no fine-tuning).

Typical Common Source S-Parameters

CFY66-08: $V_{DS} = 2\text{ V}$, $I_D = 10\text{ mA}$, $Z_o = 50\ \Omega$											
f	S11	<S11	S21	<S21	S12	<S12	S22	<S22	k-Fact.	S_{21}/S_{12}	MAG
[GHz]	[magn]	[angle]	[magn]	[angle]	[magn]	[angle]	[magn]	[angle]	[magn]	[dB]	[dB]
1,0	0,990	-21	4,451	161	0,0260	70	0,649	-16	0,14	22,3	
2,0	0,960	-39	4,282	144	0,0460	61	0,623	-29	0,19	19,7	
3,0	0,920	-57	4,148	126	0,0650	49	0,589	-43	0,27	18,0	
4,0	0,880	-77	3,979	108	0,0830	37	0,560	-57	0,32	16,8	
5,0	0,830	-95	3,727	93	0,0940	25	0,532	-70	0,39	16,0	
6,0	0,790	-111	3,444	78	0,1000	14	0,506	-83	0,47	15,4	
7,0	0,749	-124	3,206	64	0,1060	6	0,490	-94	0,55	14,8	
8,0	0,720	-137	3,029	50	0,1110	-3	0,463	-103	0,63	14,4	
9,0	0,690	-150	2,907	38	0,1130	-11	0,440	-113	0,70	14,1	
10,0	0,670	-165	2,845	25	0,1190	-20	0,420	-121	0,74	13,8	
11,0	0,649	179	2,787	11	0,1210	-28	0,400	-130	0,79	13,6	
12,0	0,628	164	2,699	-3	0,1200	-37	0,385	-143	0,84	13,5	
13,0	0,610	151	2,614	-16	0,1200	-46	0,370	-153	0,91	13,4	
14,0	0,597	138	2,584	-28	0,1190	-55	0,355	-162	0,96	13,4	
15,0	0,584	121	2,550	-42	0,1180	-66	0,340	-172	1,01	13,3	12,8
16,0	0,580	104	2,484	-56	0,1170	-76	0,330	178	1,05	13,3	11,9
17,0	0,580	89	2,461	-71	0,1150	-87	0,325	169	1,08	13,3	11,5
18,0	0,580	74	2,456	-86	0,1160	-100	0,320	160	1,09	13,3	11,4

Typical Common Source Noise-Parameters

CFY66-08: $V_{DS} = 2\text{ V}$, $I_D = 10\text{ mA}$, $Z_o = 50\ \Omega$				
f	NF _{min}	$ \Gamma_{opt} $	$\angle\Gamma_{opt}$	R_n
[GHz]	[dB]	[magn]	[angle]	[Ω]
1	0,27	0,770	16	17,85
2	0,31	0,720	30	16,55
3	0,35	0,672	43	15,27
4	0,38	0,634	57	13,75
5	0,42	0,604	71	11,99
6	0,46	0,578	85	10,04
7	0,50	0,558	100	8,15
8	0,55	0,541	114	6,30
9	0,60	0,528	128	4,74
10	0,65	0,517	143	3,45
11	0,70	0,506	157	2,58
12	0,74	0,496	171	2,16
13	0,79	0,485	-175	2,27
14	0,85	0,472	-160	2,88
15	0,89	0,457	-146	3,99
16	0,95	0,437	-132	5,59
17	1,00	0,415	-118	7,63
18	1,06	0,389	-102	9,96

Order Instructions:

Full type variant including quality level must be specified by the orderer. For *HiRel* Discrete and Microwave Semiconductors the ordering code specifies device family and quality level only.

Ordering Form:

Ordering Code: Q.....
CFY66 -(nnl) (ql)
-(nnl) Noise Figure/Gain and/or Power Level
(ql): Quality Level

Ordering Example:

Ordering Code: (on request)
CFY66-08P ES
For CFY66, Noise Figure/Gain/Power Level 08P:
NF < 0.8 dB, $G_a > 10.0$ dB, $P_{1dB} > 10$ dBm @ 12 GHz
in ESA Space Quality Level

Further Informations:

See our WWW-Pages:

- Discrete and RF-Semiconductors (Small Signal Semiconductors)

www.infineon.com/products/discrete/hirel.htm

- *HiRel* Discrete and Microwave Semiconductors

www.infineon.com/products/discrete/hirel.htm

Please contact also our marketing division :

Address: Infineon Technologies AG

AIM DS M 2

Sabine Stimmler

P.O.Box 800949,

D-81609 Munich

Micro-X Package

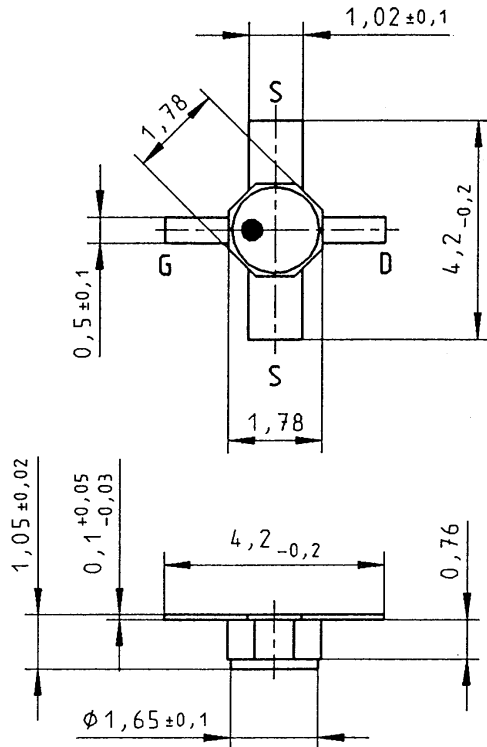

Published by Infineon Technologies Semiconductors, High Frequency Products Marketing, P.O.Box 801709, D-81617 Munich.

© Infineon Technologies AG 1998. All Rights Reserved.

As far as patents or other rights of third parties are concerned, liability is only assumed for components per se, not for applications, processes and circuits implemented within components or assemblies.

The information describes the type of component and shall not be considered as assured characteristics.

Terms of delivery and rights to change design reserved.

For questions on technology, delivery and prices please contact the Offices of Semiconductor Group in Germany or the Infineon Technologies Companies and Representatives worldwide (see address list).

Due to technical requirements components may contain dangerous substances. For information on the type in question please contact your nearest Infineon Technologies Office, Semiconductor Group.

Infineon Technologies Semiconductors is a certified CECC and QS9000 manufacturer (this includes ISO 9000).