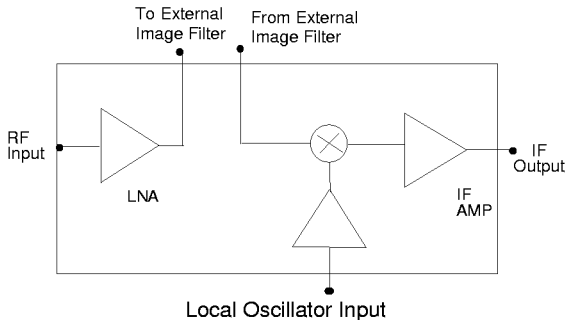

FEATURES	FUNCTIONAL BLOCK DIAGRAM
<ul style="list-style-type: none"> ■ Monolithic Down Converter ■ 3 dB Noise Figure ■ 17 dB Conversion Gain ■ Single +3.6 V Supply ■ 14 Pin SOIC ■ Low Power Consumption 	

The ANADIGICS Wireless receiver is a fully monolithic downconverter intended for cellular telephone, cordless telephone and wireless local area network (LAN) applications in the 800 MHz to 1 GHz frequency range.

The high level of integration enables wireless manufacturers to produce in high volume, receivers with reduced component count, resulting in higher reliability and lower cost.

The very small package and low current consumption make the AWR8003 ideal for both hand held and battery operated applications.

ABSOLUTE MAXIMUM RATINGS

PARAMETER	MIN.	MAX.	UNITS
V_{DD}/V_{IF}		+ 8	V
$V_{RF}/ V_{LO}/ V_{LNA Out}/V_{MIXER}$		+ 10	V
Case Temperature	- 55	+ 85	°C
Storage Temperature	- 55	+150	°C
Input Power RF(All Ports)		+ 10	dBm

This data sheet contains technical information about product ANADIGICS is planning to introduce. The data and product specifications are subject to change prior to formal introduction. Please note the device are NOT to be used for device qualification or production.

Electrical Specs ($V_{DD} = +3.6\text{ V}$; $R_F = 881.5\text{ MHz}$, $LO = 956.5\text{ MHz}$, $IF = 75\text{ MHz}$, $T_C = 25^\circ\text{C}$)

PARAMETER	MIN.	TYP.	MAX.	UNITS
Frequency Range RF IF	800 45		1000 150	MHz
Conversion Gain ¹		17		dB
Noise Figure ¹		3.0		dB
Input 3rd Order Intercept (IIP ₃)		- 10		dBm
LO Drive Level		- 5		dBm
RF Input Impedance	TBD			
IF Output Impedance	TBD			
Power supply current (+3.6 V)		10		mA
Operating Temperature Range*	-30		+ 85*	°C
Operating Supply Voltage		3.6		Volts

* Operation above this temperature will degrade the median time to failure (MTF)

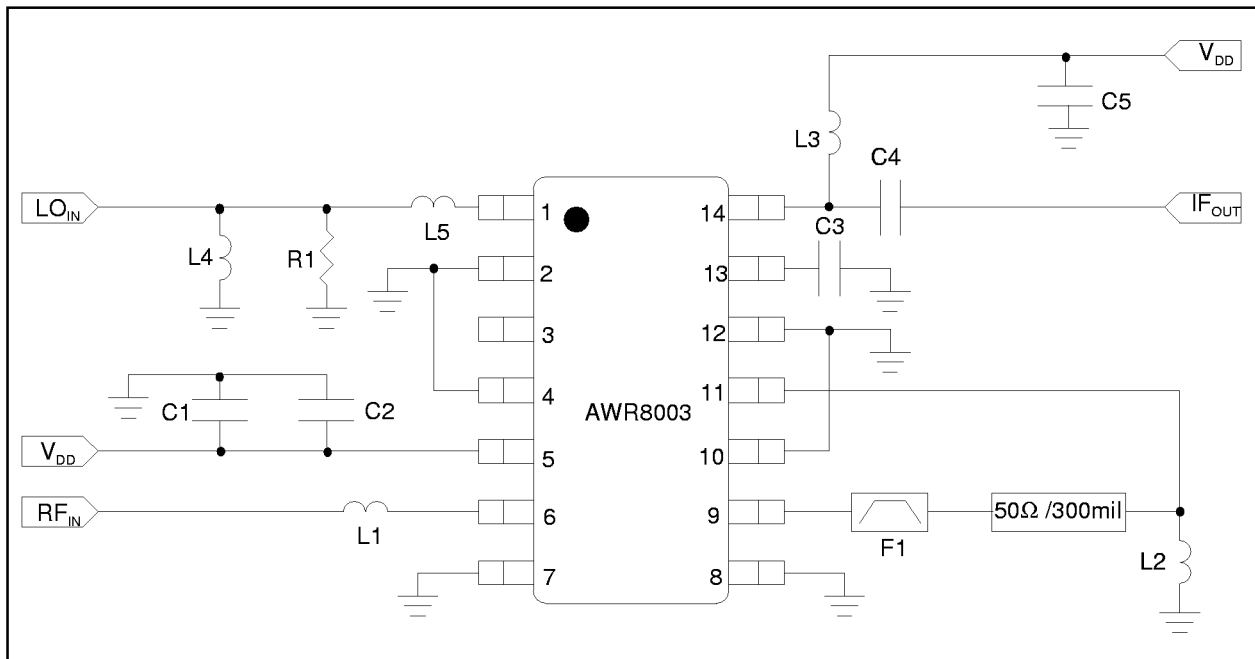

1. As measured in ANADIGICS test fixture with bandpass filter between LNA output and Mixer input. Filter loss $\approx 2\text{dB}$.

This data sheet contains technical information about product ANADIGICS is planning to introduce. The data and product specifications are subject to change prior to formal introduction. Please note the device are NOT to be used for device qualification or production.

PIN	SIGNAL
1	LO _{IN}
2	GND
3	N/C
4	GND
5	V _{DD}
6	RF _{IN}
7	GND
8	GND
9	LNA _{OUT}
10	GND
11	MXR _{IN}
12	GND
13	C _{IF}
14	IF _{OUT} , V _{DD}

PARTS LIST		
ITEM	VALUE	TYPE
C1	0.033 μ f	0402
C2	0.033 μ f	0402
C3	0.033 μ f	0402
C4	15 pf	0402
C5	33 pf	0402
R1	510 Ω	0603
L1	15 nH	0603
L2	15 nH	0603
L3	220 nH	C.C. 0805
L4	4.7 nH	0603
L5	8.2 nH	0603
F1	LFA30	869-894

This data sheet contains technical information about product ANADIGICS is planning to introduce. The data and product specifications are subject to change prior to formal introduction. Please note the device are NOT to be used for device qualification or production.