

# SN74ALS164A

## 8-BIT PARALLEL-OUT SERIAL SHIFT REGISTER

SDAS159D – APRIL 1982 – REVISED DECEMBER 1994

- AND-Gated (Enable/Disable) Serial Inputs
- Fully Buffered Clock and Serial Inputs
- Direct Clear
- Package Options Include Plastic Small-Outline (D) Packages and Standard Plastic (N) 300-mil DIPs

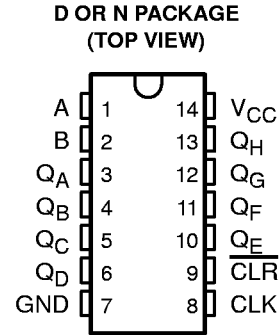

### description

This 8-bit parallel-out serial shift register features AND-gated serial (A and B) inputs and an asynchronous clear ( $\overline{\text{CLR}}$ ) input. The gated serial inputs permit control over incoming data because a low at either input inhibits entry of the new data and resets the first flip-flop to the low level at the next clock pulse. A high-level input enables the other input, which determines the state of the first flip-flop. Data at the serial inputs can be changed while the clock is high or low, provided that the minimum setup-time requirements are met. Clocking occurs on the low-to-high-level transition of the clock (CLK) input. All inputs are diode clamped to minimize transmission-line effects.

The SN74ALS164A is characterized for operation from 0°C to 70°C.

**FUNCTION TABLE**

INPUTS				OUTPUTS <sup>†</sup>		
$\overline{\text{CLR}}$	CLK	A	B	Q <sub>A</sub>	Q <sub>B</sub> . . .	Q <sub>H</sub>
L	X	X	X	L	L	L
H	L	X	X	Q <sub>A0</sub>	Q <sub>B0</sub>	Q <sub>H0</sub>
H	↑	H	H	H	Q <sub>An</sub>	Q <sub>Gn</sub>
H	↑	L	X	L	Q <sub>An</sub>	Q <sub>Gn</sub>
H	↑	X	L	L	Q <sub>An</sub>	Q <sub>Gn</sub>

<sup>†</sup> Q<sub>A0</sub>, Q<sub>B0</sub>, Q<sub>H0</sub> = the level of Q<sub>A</sub>, Q<sub>B</sub>, or Q<sub>H</sub>, respectively, before the indicated steady-state input conditions were established.

H = high level (steady state), L = low level (steady state)

X = irrelevant (any input, including transitions)

↑ = transition from low to high level

Q<sub>An</sub>, Q<sub>Gn</sub> = the level of Q<sub>A</sub> or Q<sub>G</sub> before the most recent

↑ transition of the clock; indicates a 1-bit shift.

# SN74ALS164A 8-BIT PARALLEL-OUT SERIAL SHIFT REGISTER

SDAS159D – APRIL 1982 – REVISED DECEMBER 1994

## logic symbol†

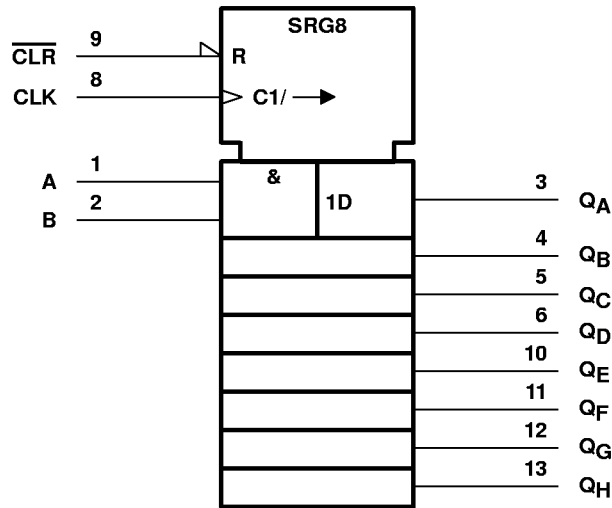

† This symbol is in accordance with ANSI/IEEE Std 91-1984 and IEC Publication 617-12.

## logic diagram (positive logic)

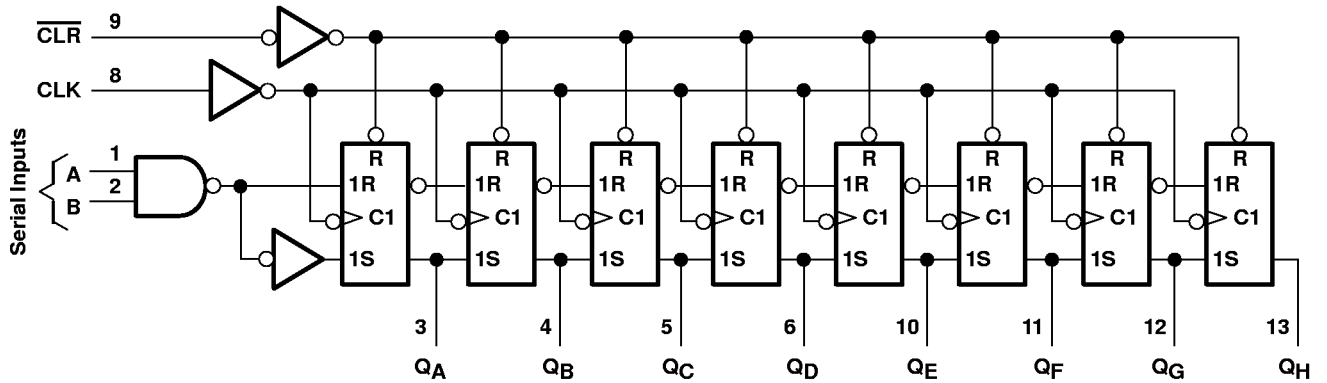

# SN74ALS164A 8-BIT PARALLEL-OUT SERIAL SHIFT REGISTER

SDAS159D – APRIL 1982 – REVISED DECEMBER 1994

## typical clear, shift, and clear sequences

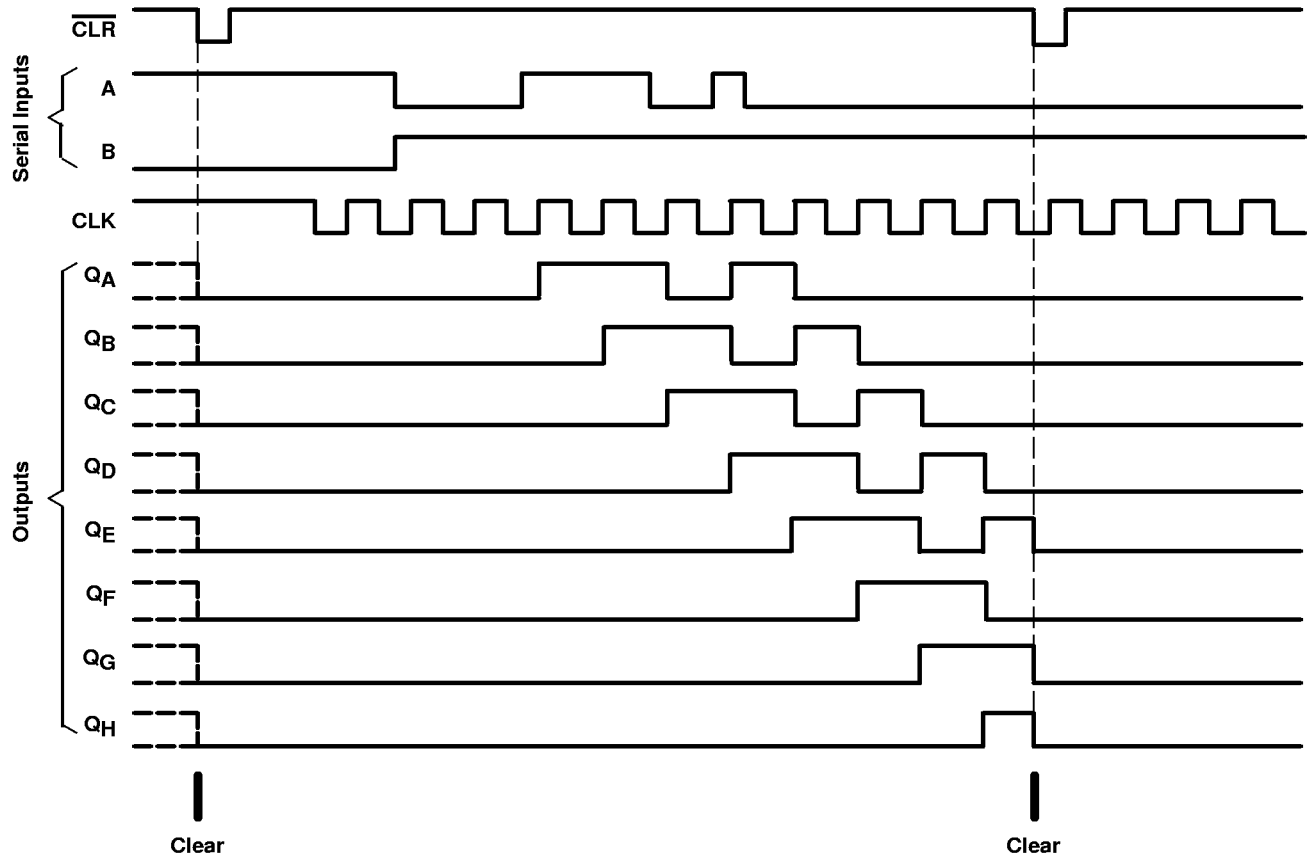

## absolute maximum ratings over operating free-air temperature range (unless otherwise noted)<sup>†</sup>

Supply voltage, $V_{CC}$ .....	7 V
Input voltage, $V_I$ .....	7 V
Operating free-air temperature range, $T_A$ .....	0°C to 70°C
Storage temperature range .....	-65°C to 150°C

<sup>†</sup> Stresses beyond those listed under "absolute maximum ratings" may cause permanent damage to the device. These are stress ratings only, and functional operation of the device at these or any other conditions beyond those indicated under "recommended operating conditions" is not implied. Exposure to absolute-maximum-rated conditions for extended periods may affect device reliability.

# SN74ALS164A

## 8-BIT PARALLEL-OUT SERIAL SHIFT REGISTER

SDAS159D – APRIL 1982 – REVISED DECEMBER 1994

### recommended operating conditions

		MIN	NOM	MAX	UNIT
V <sub>CC</sub>	Supply voltage	4.5	5	5.5	V
V <sub>IH</sub>	High-level input voltage	2			V
V <sub>IL</sub>	Low-level input voltage			0.8	V
I <sub>OH</sub>	High-level output current			-0.4	mA
I <sub>OL</sub>	Low-level output current			8	mA
f <sub>clock</sub>	Clock frequency			50	MHz
t <sub>w</sub>	Pulse duration	CLK	10		ns
		CLR low	16		
t <sub>su</sub>	Setup time before CLK↑	Data	6		ns
		CLR inactive	8		
t <sub>h</sub>	Hold time, data after CLK↑	2			ns
T <sub>A</sub>	Operating free-air temperature	0		70	°C

### electrical characteristics over recommended operating free-air temperature range (unless otherwise noted)

PARAMETER	TEST CONDITIONS		MIN	TYP†	MAX	UNIT
V <sub>IK</sub>	V <sub>CC</sub> = 4.5 V,	I <sub>I</sub> = -18 mA			-1.5	V
V <sub>OH</sub>	V <sub>CC</sub> = 4.5 V to 5.5 V,	I <sub>OH</sub> = -0.4 mA	V <sub>CC</sub> - 2			V
V <sub>OL</sub>	V <sub>CC</sub> = 4.5 V	I <sub>OL</sub> = 4 mA		0.25	0.4	V
		I <sub>OL</sub> = 8 mA		0.35	0.5	
I <sub>I</sub>	V <sub>CC</sub> = 5.5 V,	V <sub>I</sub> = 7 V			0.1	mA
I <sub>IH</sub>	V <sub>CC</sub> = 5.5 V,	V <sub>I</sub> = 2.7 V			20	μA
I <sub>IL</sub>	V <sub>CC</sub> = 5.5 V,	V <sub>I</sub> = 0.4 V			-0.1	mA
I <sub>O‡</sub>	V <sub>CC</sub> = 5.5 V,	V <sub>O</sub> = 2.25 V	-30		-112	mA
I <sub>CC</sub>	V <sub>CC</sub> = 5.5 V,	See Note 1		14	24	mA

† All typical values are at V<sub>CC</sub> = 5 V, T<sub>A</sub> = 25°C.

‡ The output conditions have been chosen to produce a current that closely approximates one half of the true short-circuit output current, I<sub>OS</sub>.

NOTE 1: With 4.5 V applied to the serial input and all other inputs, except the CLK, grounded, I<sub>CC</sub> is measured after a clock transition from 0 to 4.5 V.

### switching characteristics (see Figure 1)

PARAMETER	FROM (INPUT)	TO (OUTPUT)	V <sub>CC</sub> = 4.5 V to 5.5 V, C <sub>L</sub> = 50 pF, R <sub>L</sub> = 500 Ω, T <sub>A</sub> = MIN to MAX§			UNIT
			MIN	TYP¶	MAX	
f <sub>max</sub>			50	75		MHz
t <sub>PHL</sub>	CLR	Any Q	6	15	20	ns
t <sub>PLH</sub>	CLK	Any Q	4	9	16	ns
t <sub>PHL</sub>			5	11	17	

§ For conditions shown as MIN or MAX, use the appropriate value specified under recommended operating conditions.

¶ All typical values are at V<sub>CC</sub> = 5 V, T<sub>A</sub> = 25°C.



# SN74ALS164A 8-BIT PARALLEL-OUT SERIAL SHIFT REGISTER

SDAS159D – APRIL 1982 – REVISED DECEMBER 1994

## PARAMETER MEASUREMENT INFORMATION SERIES 54ALS/74ALS AND 54AS/74AS DEVICES

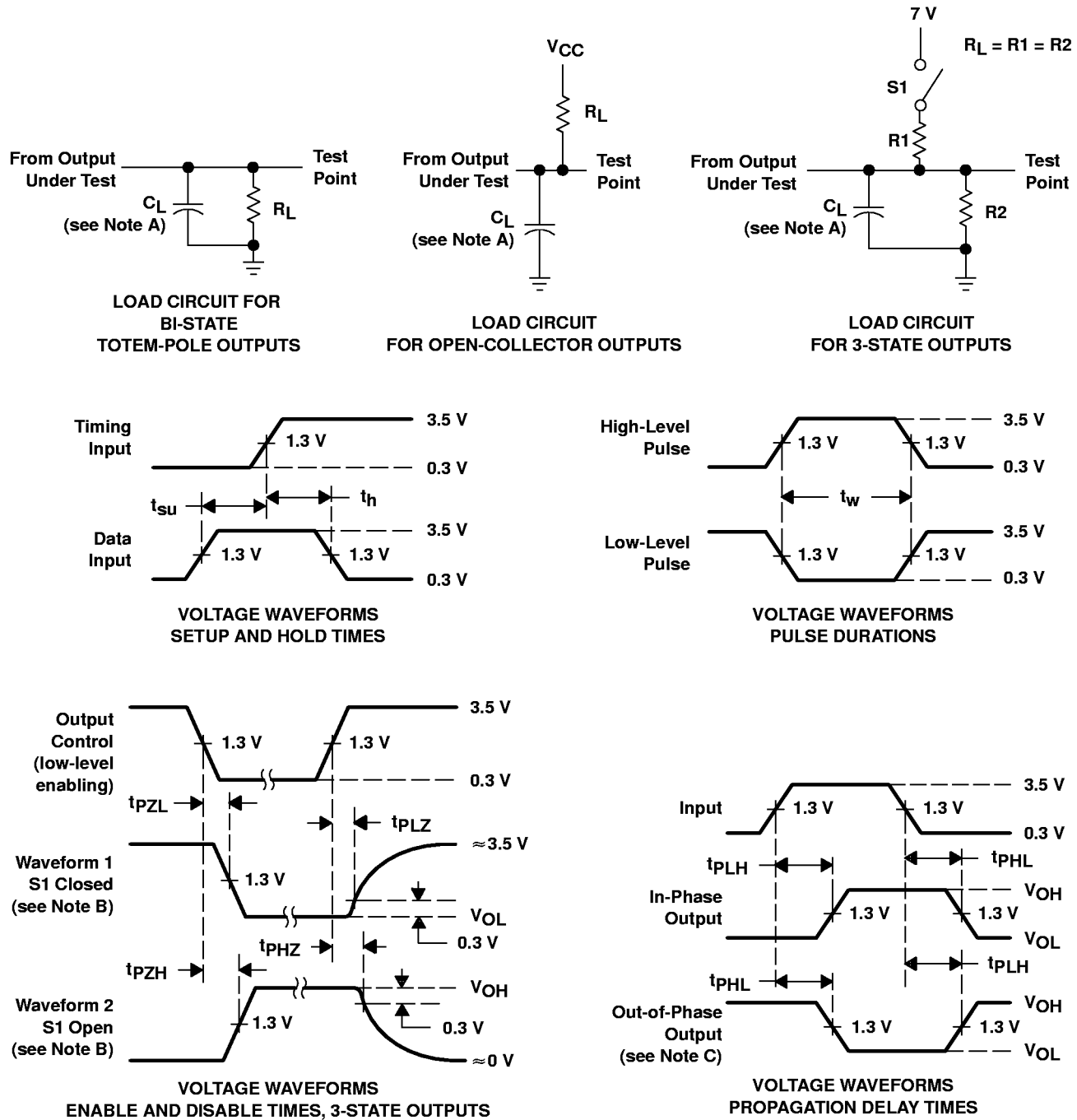

- NOTES: A.  $C_L$  includes probe and jig capacitance.  
 B. Waveform 1 is for an output with internal conditions such that the output is low except when disabled by the output control. Waveform 2 is for an output with internal conditions such that the output is high except when disabled by the output control.  
 C. When measuring propagation delay items of 3-state outputs, switch S1 is open.  
 D. All input pulses have the following characteristics:  $PRR \leq 1$  MHz,  $t_r = t_f = 2$  ns, duty cycle = 50%.  
 E. The outputs are measured one at a time with one transition per measurement.

**Figure 1. Load Circuits and Voltage Waveforms**

## **IMPORTANT NOTICE**

Texas Instruments (TI) reserves the right to make changes to its products or to discontinue any semiconductor product or service without notice, and advises its customers to obtain the latest version of relevant information to verify, before placing orders, that the information being relied on is current.

TI warrants performance of its semiconductor products and related software to the specifications applicable at the time of sale in accordance with TI's standard warranty. Testing and other quality control techniques are utilized to the extent TI deems necessary to support this warranty. Specific testing of all parameters of each device is not necessarily performed, except those mandated by government requirements.

Certain applications using semiconductor products may involve potential risks of death, personal injury, or severe property or environmental damage ("Critical Applications").

**TI SEMICONDUCTOR PRODUCTS ARE NOT DESIGNED, INTENDED, AUTHORIZED, OR WARRANTED TO BE SUITABLE FOR USE IN LIFE-SUPPORT APPLICATIONS, DEVICES OR SYSTEMS OR OTHER CRITICAL APPLICATIONS.**

Inclusion of TI products in such applications is understood to be fully at the risk of the customer. Use of TI products in such applications requires the written approval of an appropriate TI officer. Questions concerning potential risk applications should be directed to TI through a local SC sales office.

In order to minimize risks associated with the customer's applications, adequate design and operating safeguards should be provided by the customer to minimize inherent or procedural hazards.

TI assumes no liability for applications assistance, customer product design, software performance, or infringement of patents or services described herein. Nor does TI warrant or represent that any license, either express or implied, is granted under any patent right, copyright, mask work right, or other intellectual property right of TI covering or relating to any combination, machine, or process in which such semiconductor products or services might be or are used.