

The EF6854 ADLC performs the complex MPU/data communication link function for the "Advanced Data Communication Control Procedure" (ADCCP), High-Level Data-Link Control (HDLC) and Synchronous Data-Link Control (SDLC) standards. The ADLC provides key interface requirements with improved software efficiency. The ADLC is designed to provide the data communications interface for both primary and secondary stations in stand-alone, polling, and loop configurations.

- 6800 Compatible
- Protocol Features
 - Automatic Flag Detection and Synchronization
 - Zero Insertion and Deletion
 - Extendable Address, Control and Logical Control Fields (Optional)
 - Variable Word Length Information Field - 5-, 6-, 7-, or 8-Bits
 - Automatic Frame Check Sequence Generation and Check
 - Abort Detection and Transmission
 - Idle Detection and Transmission
- Loop Mode Operation
- Loop Back Self-Test Mode
- NRZ/NRZI Modes
- Quad Data Buffers for Each Rx and Tx
- Prioritized Status Register (Optional)
- MODEM/DMA/Loop Interface
- Three available versions : EF6854 (1.0 MHz)
EF68A54 (1.5 MHz)
EF68B54 (2.0 MHz)

MOS

(IN-CHANNEL, SILICON GATE)

ADVANCED DATA-LINK CONTROLLER

CASES

CB-132

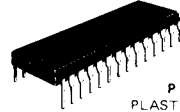

P SUFFIX
PLASTIC PACKAGE

ALSO AVAILABLE

J SUFFIX
CERDIP PACKAGE

C SUFFIX
CERAMIC PACKAGE

CB-520



FN SUFFIX
PLCC 28

CB-707



E SUFFIX
LCC 26

Hi-Rel versions available - See chapter 9

PIN ASSIGNMENT

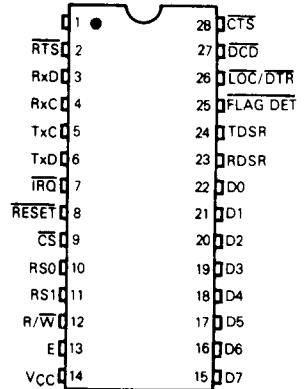

MAXIMUM RATINGS

Rating	Symbol	Value	Unit
Supply Voltage	V _{CC}	-0.3 to +7.0	V
Input Voltage	V _{in}	-0.3 to +7.0	V
Operating Temperature Range EF6854, EF68A54, EF68B54 EF6854, EF68A54, EF68B54 EF68B54 : V suffix EF6854, EF68A54 : M suffix	T _A	(T _L to T _H) 0 to 70 -40 to 85 -55 to +125	°C
Storage Temperature Range	T _{stg}	-55 to +150	°C

This device contains circuitry to protect the inputs against damage due to high static voltages or electric fields; however, it is advised that normal precautions be taken to avoid application of any voltage higher than maximum rated voltages to this high-impedance circuit. Reliability of operation is enhanced if unused inputs are tied to an appropriate logic voltage level (e.g., either V_{SS} or V_{CC}).

THERMAL CHARACTERISTICS

Characteristic	Symbol	Value	Unit
Thermal Resistance			
Plastic	θ _{JA}	115	°C/W
Ceramic		60	
Cerdip		65	
PLCC		100	

FIGURE 1 — ADC GENERAL BLOCK DIAGRAM

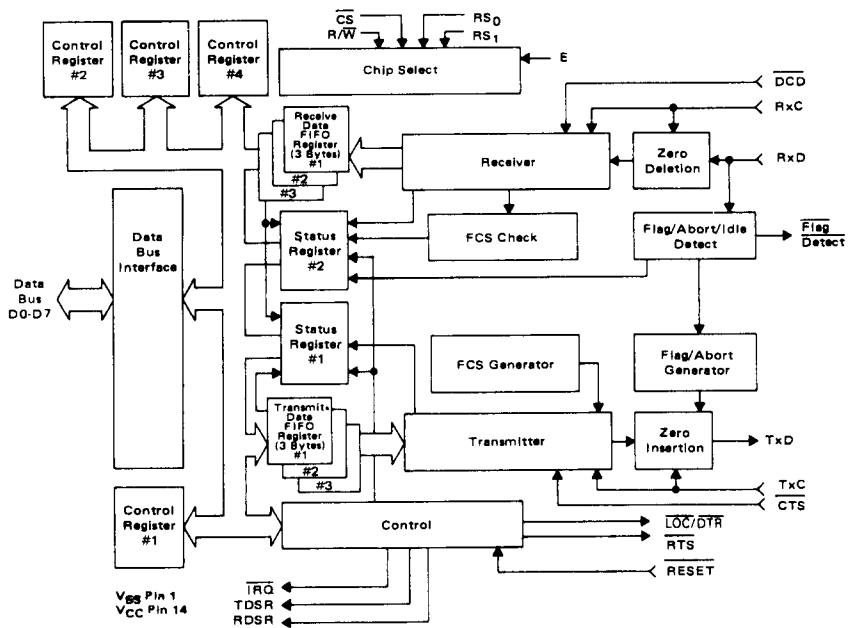

POWER CONSIDERATIONS

The average chip-junction temperature, T_J , in °C can be obtained from:

$$T_J = T_A + (P_D \cdot \theta_{JA}) \quad (1)$$

Where:

T_A = Ambient Temperature, °C

θ_{JA} = Package Thermal Resistance, Junction-to-Ambient, °C/W

P_D = $P_{INT} + P_{PORT}$

P_{INT} = $I_{CC} \times V_{CC}$, Watts – Chip Internal Power

P_{PORT} = Port Power Dissipation, Watts – User Determined

For most applications $P_{PORT} \ll P_{INT}$ and can be neglected. P_{PORT} may become significant if the device is configured to drive Darlington bases or sink LED loads.

An approximate relationship between P_D and T_J (if P_{PORT} is neglected) is:

$$P_D = K + (T_J + 273^\circ\text{C}) \quad (2)$$

Solving equations 1 and 2 for K gives:

$$K = P_D \cdot (T_A + 273^\circ\text{C}) + \theta_{JA} \cdot P_D^2 \quad (3)$$

Where K is a constant pertaining to the particular part. K can be determined from equation 3 by measuring P_D (at equilibrium) for a known T_A . Using this value of K the values of P_D and T_J can be obtained by solving equations (1) and (2) iteratively for any value of T_A .

DC ELECTRICAL CHARACTERISTICS ($V_{CC} = 5.0 \text{ Vdc} \pm 5\%$, $V_{SS} = 0$, $T_A = T_L$ to T_H unless otherwise noted)

Characteristic	Symbol	Min	Typ	Max	Unit
Input High Voltage	V_{IH}	$V_{SS} + 2.0$	–	–	V
Input Low Voltage	V_{IL}	–	–	$V_{SS} + 0.8$	V
Input Leakage Current ($V_{IN} = 0$ to 5.25 V)	I_{in}	–	1.0	2.5	μA
Hi-Z (Off-State) Input Current ($V_{IN} = 0.4$ to 2.4 V , $V_{CC} = 5.25 \text{ V}$)	I_{IZ}	–	2.0	10	μA
dc Output High Voltage ($I_{Load} = -205 \mu\text{A}$) ($V_{Load} = -100 \mu\text{A}$)	V_{OH}	$V_{SS} + 2.4$ $V_{SS} + 2.4$	–	–	V
dc Output Low Voltage ($I_{Load} = 1.6 \text{ mA}$)	V_{OL}	–	–	$V_{SS} + 0.4$	V
Output Leakage Current (Off State) ($V_{OH} = 2.4 \text{ V}$)	I_{OZ}	–	1.0	10	μA
Internal Power Dissipation (measured at $T_A = 0^\circ\text{C}$)	P_{INT}	–	–	850*	mW
Capacitance ($V_{IN} = 0$, $T_A = 25^\circ\text{C}$, $f = 1.0 \text{ MHz}$)	C_{in}	–	–	12.5 7.5	pF
	C_{out}	–	–	5.0 10	pF

*For temperatures below 0°C , P_{INT} will increase.

AC ELECTRICAL CHARACTERISTICS ($V_{CC} = 5.0 \text{ V} \pm 5\%$, $V_{SS} = 0$, $T_A = T_L$ to T_H unless otherwise noted)

Characteristic	Symbol	EF6854		EF68A54		EF68B54		Unit
		Min	Max	Min	Max	Min	Max	
Clock Pulse Width, Low (RxC, TxC)	PW_{CL}	700	–	450	–	280	–	ns
Clock Pulse Width, High (RxC, TxC)	PW_{CH}	700	–	450	–	280	–	ns
Serial Clock Frequency (RxC, TxC)	f_{SC}	–	0.66	–	1.0	–	1.5	MHz
Receive Data Setup Time	t_{RDSU}	150	–	100	–	50	–	ns
Receive Data Hold Time	t_{RDH}	60	–	60	–	60	–	ns
Request-to-Send Delay Time	t_{RTS}	–	680	–	460	–	340	ns
Clock-to-Data Delay for Transmitter	t_{TDD}	–	300	–	250	–	200	ns
Flag Detect Delay Time	t_{FD}	–	680	–	460	–	340	ns
DTR Delay Time	t_{DTR}	–	680	–	460	–	340	ns
Loop On-Line Control Delay Time	t_{LOC}	–	680	–	460	–	340	ns
RDSR Delay Time	t_{RDSR}	–	540	–	400	–	340	ns
TDSR Delay Time	t_{TDSR}	–	540	–	400	–	340	ns
Interrupt Request Release Time	t_{IR}	–	1.2	–	0.9	–	0.7	μs
RESET Pulse Width	t_{RESET}	1.0	–	0.65	–	0.40	–	μs
Input Rise and Fall Times (Except Enable) (0.8 V to 2.0 V)	t_r, t_f	–	1.0*	–	1.0*	–	1.0*	μs

*1.0 μs or 10% of the pulse width, whichever is smaller.

FIGURE 2 — BUS TIMING TEST LOADS

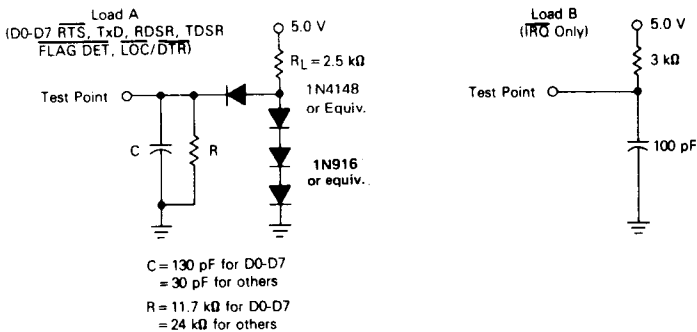

FIGURE 3 — RECEIVER DATA SETUP/HOLD, FLAG DETECT AND LOOP ON-LINE CONTROL DELAY TIMING

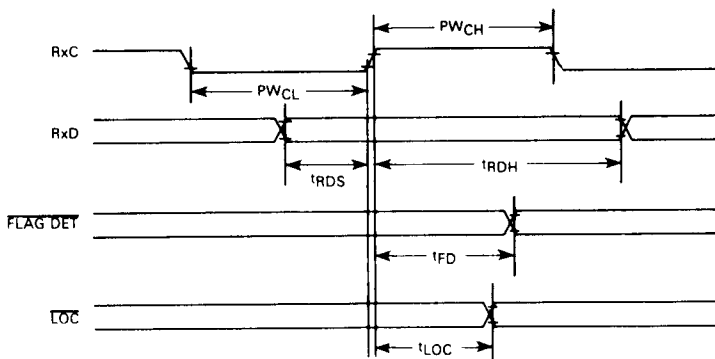
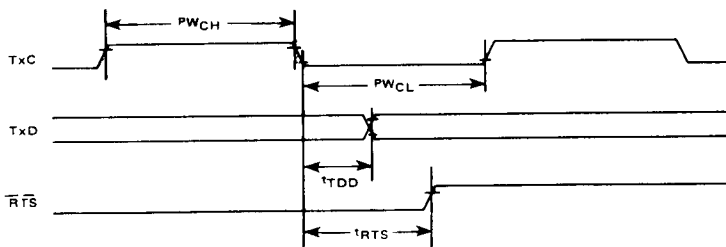
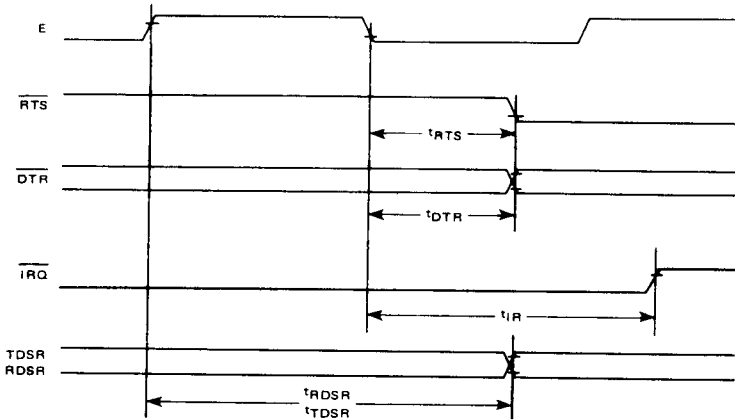

FIGURE 4 — TRANSMIT DATA OUTPUT DELAY AND REQUEST-TO-SEND DELAY TIMING



NOTE: Timing measurements are referenced to and from a low voltage of 0.8 volt and a high voltage of 2.0 volts, unless otherwise noted.

FIGURE 5 — TDSR/RDSR DELAYS, $\overline{\text{IRQ}}$ RELEASE DELAY, $\overline{\text{RTS}}$ AND $\overline{\text{DTR}}$ DELAY TIMING



NOTE: Timing measurements are referenced to and from a low voltage of 0.8 volt and a high voltage of 2.0 volts, unless otherwise noted.

BUS TIMING CHARACTERISTICS (See Notes 1 and 2)

Ident. Number	Characteristics	Symbol	EF6854		EF68A54		EF68B54		Unit
			Min	Max	Min	Max	Min	Max	
1	Cycle Time	t_{cyc}	1.0	10	0.67	10	0.5	10	μs
2	Pulse Width, E Low	PW _{EL}	430	9500	280	9500	210	9500	ns
3	Pulse Width, E High	PW _{EH}	450	9500	280	9500	220	9500	ns
4	Clock Rise and Fall Time	$t_{\text{r, f}}$	—	25	—	25	—	20	ns
9	Address Hold Time	t_{AH}	10	—	10	—	10	—	ns
13	Address Setup Time Before E	t_{AS}	80	—	60	—	40	—	ns
14	Chip Select Setup Time Before E	t_{CS}	80	—	60	—	40	—	ns
15	Chip Select Hold Time	t_{CH}	10	—	10	—	10	—	ns
18	Read Data Hold Time	t_{DHR}	10	50*	20	50*	20	50*	ns
21	Write Data Hold Time	t_{DHW}	10	—	10	—	10	—	ns
30	Output Data Delay Time	t_{DDR}	—	290	—	180	—	150	ns
31	Input Data Setup Time	t_{DSW}	165	—	80	—	60	—	ns

*The data bus output buffers are no longer sourcing or sinking current by t_{DHRmax} (High Impedance).

FIGURE 6 — BUS TIMING

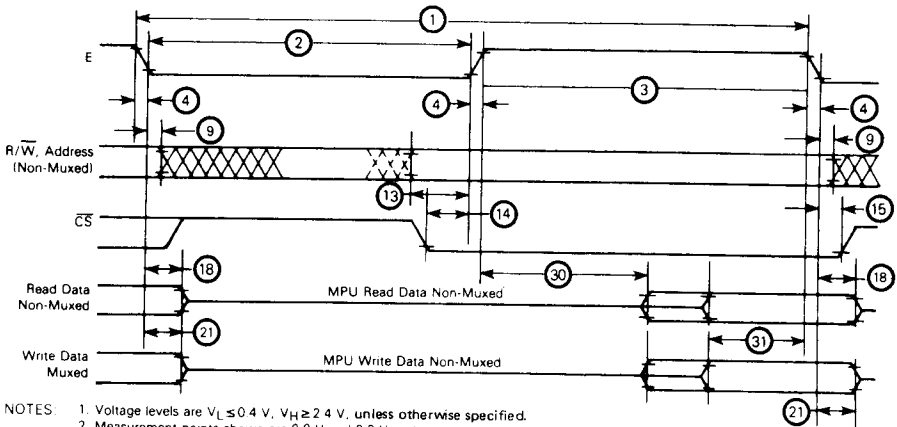

NOTES: 1. Voltage levels are $V_L \leq 0.4 \text{ V}$, $V_H \geq 2.4 \text{ V}$, unless otherwise specified.
2. Measurement points shown are 0.8 V and 2.0 V, unless otherwise specified.

FRAME FORMAT

The ADLC transmits and receives data (information or control) in a format called a frame. All frames start with an opening flag (F) and end with a closing flag (F). Between the

opening flag and closing flag, a frame contains an address field, control field, information field (optional) and frame check sequence field.

FIGURE 7 — DATA FORMAT OF A FRAME

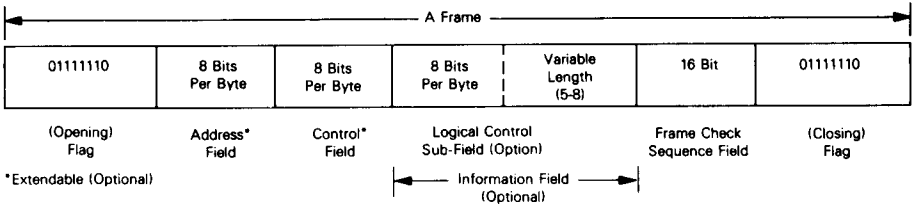

Flag (F) — The flag is the unique binary pattern (01111110). It provides the frame boundary and a reference for the position of each field of the frame.

The ADLC transmitter generates a flag pattern internally and the opening flag and closing flags are appended to a frame automatically. Two successive frames can share one flag for a closing flag of the first frame and for the opening flag of the next frame, if the "FF"/"F" control bit in the control register is reset.

The receiver searches for a flag on a bit-by-bit basis and recognizes a flag at any time. The receiver establishes the frame synchronization with every flag. The flags mark the frame boundary and reference for each field but they are not transferred to the Rx FIFO. The detection of a flag is indicated by the Flag Detect output and by a status bit in the status register.

Order of Bit Transmission — Address, control and information field bytes are transferred between the MPU and the ADLC in parallel by means of the data bus. The bit on D0 (data bus bit 0, pin 22) is serially transmitted first, and the first serially received bit is transferred to the MPU on D0. The FCS field is transmitted and received MSB first.

Address (A) Field — The 8 bits following the opening flag are the address (A) field. The A-field can be extendable if the Auto-Address Extend Mode is selected in control register #3. In the Address Extend Mode, the first bit (bit 0) in every address octet becomes the extend control bit. When the bit is "0", the ADLC assumes another address octet will follow, and when the bit is "1", the address extension is terminated. A "null" address (all "0's") does not extend. In the receiver, the Address Present status bit distinguishes the address field from other fields. When an address byte is available to be read in the receive FIFO register, the Address Present status bit is set and causes an interrupt (if enabled). The Address Present bit is set for every address octet when the Address Extend Mode is used.

Control (C) Field — The 8 bits following the address field is the control (link control) field. When the Extended Control Field bit in control register #3 is selected, the C-field is extended to 16 bits.

Information (I) Field — The I-field follows the C-field and precedes the FCS field. The I-field contains "data" to be transferred but is not always necessarily contained in every frame. The word length of the I-field can be selected from 5 to 8 bits per byte by control bits in control register #4. The I-field will continue until it is terminated by the FCS and closing flag. The receiver has the capability to handle a "partial" last byte. The last information byte can be any word length between 1 and 8 bits. If the last byte in the I-field is less than the selected word length, the receiver will right justify the received bits, fill the remaining bits of the receiver shift register with zeros, and transfer a full byte to the Rx FIFO. Regardless of selected byte length, the ADLC will transfer 8 bits of data to the data bus. Unused bits for word lengths of 5, 6, and 7 will be zeroed.

Logical Control (LC) Field — When the Logical Control Field Select bit, in control register #3, is selected the ADLC separates the I-field into two sub-fields. The first sub-field is the Logical Control field and the following sub-field is the "data" portion of the I-field. The logical control field is 8 bits and follows the C-field, which is extendable by octets, if it is selected. The last bit (bit 7) is the extend control bit, and if it is a "1", the LC-field is extended one octet.

NOTE

Hereafter the word "Information field" or "I-field" is used as the data portion of the information field, and excludes the logical control field. This is done in order to keep the consistency of the meaning of "Information field" as specified in SDLC, HDLC, and ADCCP standards.

Frame Check Sequence (FCS) Field — The 16 bits preceding the closing flag is the FCS field. The FCS is the "cyclic redundancy check character (CRCC)." The polynomial $x^{16} + x^{12} + x^5 + 1$ is used both for the transmitter and receiver. Both the transmitter and receiver polynomial registers are initialized to all "1's" prior to calculation of the FCS. The transmitter calculates the FCS on all bits of the address, control, logical control (if selected), and information fields, and transmits the complement of the resulting remainder as FCS. The receiver performs the similar computation on all bits of the address, control, logical control (if selected), information, and received FCS fields and compares the result to F0B8 (Hexadecimal). When the result matches F0B8, the Frame Valid status bit is set in the status register. If the result does not match, the Error status bit is set. The FCS generation, transmission, and checking are performed automatically by the ADLC transmitter and receiver. The FCS field is not transferred to the Rx FIFO.

Invalid Frame — Any valid frames should have at least the A-field, C-field, and FCS field between the opening flag and the closing flag. When invalid frames are received, the ADLC handles them as follows:

1. A short frame which has less than 25 bits between flags — the ADLC ignores the short frame and its reception is not reported to the MPU.
2. A frame less than 32 bits between the flags, or a frame 32 bits or more with an extended A-field or C-field that is not completed. — This frame is transferred into the Rx FIFO. The FCS/IF Error status bit indicates the reception of the invalid frame at the end of the frame.
3. Aborted Frame — The frame which is aborted by receiving an abort or DCD failure is also an invalid frame. Refer to "Abort" and "DCD status bit".

Zero Insertion and Zero Deletion — The Zero insertion and deletion, which allows the content of the frame to be transparent, are performed by the ADLC automatically. A binary 0 is inserted by the transmitter after any succession of five "1's" within a frame (A, C, L, I, and FCS field). The receiver deletes a binary 0 that follows successive five continuous "1's" within a frame.

Abort — The function of prematurely terminating a data link is called "abort." The transmitter aborts a frame by sending at least eight consecutive "1's" immediately after the Tx Abort control bit in control register #4 is set to a "1". (Tx FIFO is also cleared by the Tx Abort control bit at the same time.) The abort can be extended up to (at least) 16 consecutive "1's", if the Abort Extend control bit in the control register #4 is set when an abort is sent. This feature is useful to force mark idle transmission. Reception of seven or more consecutive "1's" is interpreted as an abort by the receiver. The receiver responds to a received abort as follows:

1. An abort in an "out of frame" condition — an abort during the idle or time fill has no meaning. The abort reception is indicated in the status register as long as the abort condition continues; but neither an interrupt nor a stored status occurs. The abort indication disappears after 15 or more consecutive "1's" are received (Received Idle status is set.)
2. An abort "in frame" after less than 26 bits are received after an opening flag — under this condition, any field

of the aborted frame has not transferred to the MPU yet. The ADLC clears the aborted frame data in the FIFO and clears flag synchronization. Neither an interrupt nor a stored status occurs. The status indication is the same as (1) above.

3. An abort "in frame" after 26 bits or more are received after an opening flag — under this condition, some fields of the aborted frame might have been transferred onto the data bus. The abort status is stored in the receiver status register and the data of the aborted frame in the ADLC is cleared. The synchronization is also cleared.

Idle and Time Fill — When the transmitter is in an "out of frame" condition (the transmitter is not transmitting a frame), it is in an idle state. (Either a series of contiguous flags (time fill) or a mark idle (consecutive "1's" on a bit-by-bit basis) is selected for the transmission in an idle state by the Flag/Mark Idle control bit. When the receiver receives 15 or more consecutive "1's", the Receive Idle status bit is set and causes an interrupt. The flags and mark idle are not transferred to the Rx FIFO.

OPERATION

INITIALIZATION

During a power-on sequence, the ADLC is reset via the RESET input and internally latched in a reset condition to prevent erroneous output transitions. The four control registers must be programmed prior to the release of the reset condition. The release of the reset condition is performed via software by writing a "0" into the Rx RS control bit (receiver) and/or Tx RS control bit (transmitter). The release of the reset condition must be done after the RESET input has gone high.

At any time during operation, writing a "1" into the Rx RS control bit or Tx RS control bit causes the reset condition of the receiver or the transmitter.

TRANSMITTER OPERATION

The Tx FIFO register cannot be pre-loaded when the transmitter is in a reset state. After the reset release, the Flag/Mark Idle control bit selects either the mark idle state (inactive idle) or the Flag "time fill" (active idle) state. This active or inactive mark idle state will continue until data is loaded into the Tx FIFO.

The availability of the Tx FIFO is indicated by the TDRA status bit under the control of the 2-Byte/1-Byte control bit. TDRA status is inhibited by the Tx RS bit or CTS input being high. When the 1-Byte mode is selected, one byte of the FIFO is available for data transfer when TDRA goes high. When the 2-Byte mode is selected, two successive bytes can be transferred when TDRA goes high.

The first byte (Address field) should be written into the Tx FIFO at the "Frame Continue" address. Then the transmission of a frame automatically starts. If the transmitter is in a mark idle state, the transfer of an address causes an opening flag within two or three transmitter clock cycles. If the transmitter has been in a time fill state, the current time fill flag being transmitted is assumed as an opening flag and the address field will follow it.

FIGURE 8a — ADLC TRANSMITTER STATE DIAGRAM
(C_ij refers to control register bit)

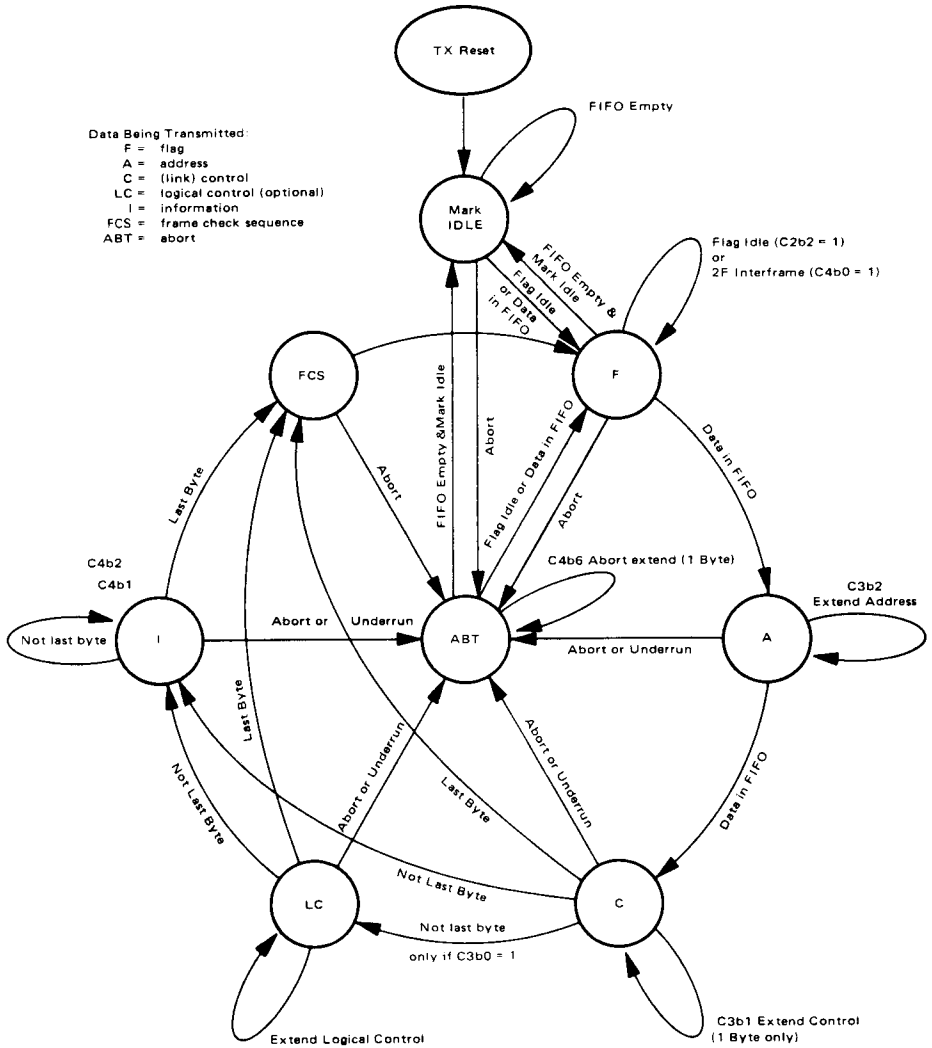

next to last bit of a word), an underrun will occur and the transmitter automatically terminates the frame by transmitting an abort. The underrun state is indicated by the Tx Underrun status bit.

Any time the Tx ABORT Control bit is set, the transmitter immediately aborts the frame (transmits at least 8 consecutive "1's") and clears the Tx FIFO. If the Abort Extend Control bit is set at the time, an idle (at least 16 consecutive "1's") is transmitted. An abort or idle in an "out of frame" condition can be useful to gain 8 or 16 bits of delay. (For an example, see "Programming Considerations.")

The CTS (Clear-to-Send) input and RTS (Request-to-Send) output are provided for a MODEM or other hardware interface.

The TDRA/FC status bit (when selected to be Frame Complete Status) can cause an interrupt upon frame completion (i.e., a flag or abort completion).

Details regarding the inputs and outputs, status bits, control bits, and FIFO operation are described in their respective sections.

RECEIVER OPERATION

Data and a pre-synchronized clock are provided to the ADLC receiver section by means of the Receive Data (RxD) and Receive Clock (RxC) inputs. The data is a continuous stream of binary bits with the characteristic that a maximum of five "1's" can occur in succession unless Abort, Flag, or Idling condition occurs. The receiver continuously (on a bit-by-bit basis) searches for Flags and Aborts.

When a flag is detected, the receiver establishes frame synchronization to the flag timing. If a series of flags is received, the receiver resynchronizes to each flag.

If the frame is terminated before the internal buffer time expires (the frame data is less than 25 bits after an opening flag), the frame is simply ignored. Noise on the data input (RxD) during time fill can cause this kind of invalid frame.

The received serial data enters a 32-bit shift register (clocked by RxC) before it is transferred into the Rx Data FIFO. Synchronization is established when a Flag is detected in the first eight locations of the shift register. Once synchronization has been achieved, data is clocked through to the last byte location of the shift register where it is transferred byte-by-byte into the Rx Data FIFO. The Rx Data FIFO is clocked by E to cause received data to move through the FIFO to the last empty register location. The Receiver Data Available status bit (RDA) indicates when data is present in the last register (Register #3) for the 1-Byte Transfer Mode. The 2-Byte Transfer Mode causes the RDA status bit to indicate data is available when the last two FIFO register locations (Registers #2 and #3) are full. If the data character present in the FIFO is an address octet, the status register will exhibit an Address Present status condition. Data being available in the Rx Data FIFO causes an interrupt to be initiated (assuming the receiver interrupt is enabled, RIE="1"). The MPU will read the ADLC Status Register as a result of the interrupt or in its turn in a polling sequence. RDA or Address Present will indicate that receiver data is available and the MPU should subsequently read the Rx Data FIFO register. The interrupt and status bit will then be reset automatically. If more than one character had been received and was resident in the Rx Data FIFO, subsequent E clocks will cause the FIFO to update and the RDA status bit and interrupt will again be SET. In the 2-Byte Transfer Mode both data bytes may be

read on consecutive E cycles. Address Present provides for 1 byte transfers only.

The sequence of each field in the received frame is automatically handled by the ADLC. The frame format is described in the "FRAME FORMAT" section.

When a closing flag is received, the frame is terminated. The 16 bits preceding the closing flag are regarded as the FCS and are not transferred to the MPU. Whatever data is present in the most-significant byte portion of the receiver buffer register it is right justified and transferred to the Rx FIFO. The frame boundary pointer, which is explained in the "Rx FIFO REGISTER" section, is set simultaneously in the Rx FIFO. The frame boundary pointer sets the Frame Valid status bit (when the frame was completed with no error) or the FCS/IF Error Status bit (when the frame was completed with error) when the last byte of the frame appears at the last location of the Rx FIFO. As long as the Frame Valid or FCS/IF Error status bit is set, the data transfer from the second location of the Rx FIFO to the last location of the Rx FIFO is inhibited.

Any time the Frame Discontinue control bit is set, the ADLC discards the current frame data in the ADLC without dropping flag synchronization. This feature can be used to ignore a frame which is addressed to another station.

The reception of an abort or idle is explained in the "FRAME FORMAT" section. The details regarding the inputs, outputs, status bits, control bits, and Rx FIFO operation are described in their respective sections.

LOOP MODE OPERATION

The ADLC in the loop mode, not only performs the transmission and receiving of data frames in the manner previously described, but also has additional features for gaining and relinquishing loop control. In Figure 9a, a configuration is shown which depicts loop mode operation. The system configuration shows a primary station and several secondary stations. The loop is always under control of the primary station. When the primary wants to receive data, it transmits a Poll sequence and allows frame transmission to secondary stations on the loop. Each secondary is in series and adds one bit of delay to the loop. Secondary A in the figure receives data from the primary via its Rx Data Input, delays the data 1 bit, and transmits it to secondary B via its Tx Data Output. Secondaries B, C, and D operate in a similar manner. Therefore, data passes through each secondary and is received back by the primary controller.

Certain protocol rules must be followed in the manner by which the secondary station places itself on-loop (connects its transmitter output to the loop), goes active on the loop (starts transmitting its own station's data on the loop), and goes off the loop (disconnects its transmitter output). Otherwise loop data to other stations down loop would be interfered. The data stream always flows the same way and the order in which secondary terminals are serviced is determined by the hardware configuration. The primary controller times the delay through the loop. Should it exceed $n + 1$ bit times, where n is the number of secondary terminals on the loop, it will indicate a loop failure. Control is transferred to a secondary by transmitting a "Go Ahead" signal following the closing Flag of a polling frame (request for a response from the secondary) from the primary station. The "Go Ahead" from the primary is a "0" and seven "1's" followed by mark

FIGURE 9a — TYPICAL LOOP CONFIGURATION

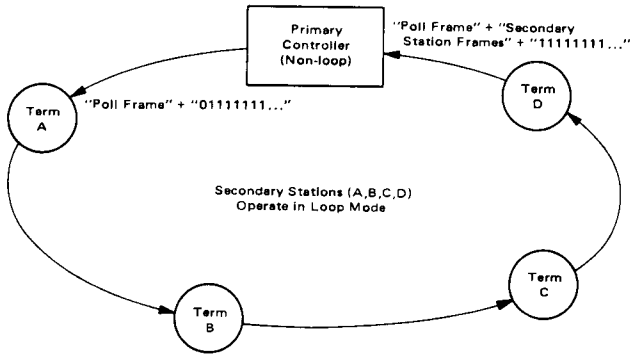
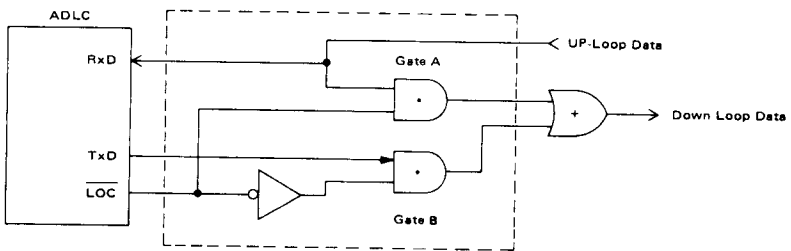

FIGURE 9b — EXAMPLE OF EXTERNAL LOOP LOGIC



idling. The primary can abort its response request by interrupting its idle with flags. The secondary should immediately stop transmission and return control back to the primary. When the secondary completes its frame, a closing flag is transmitted followed by all "1's". The primary detects the final 01111111... ("Go Ahead" to the primary) and control is given back to the primary. Note that, if a down-loop secondary (e.g., station D) needs to insert information following an up-loop station (e.g., station A), the go ahead to station D is the last "0" of the closing flag from station A followed by "1's".

The ADLC in the primary station should operate in a non-loop full-duplex mode. The ADLC in the secondaries should operate in a loop mode, monitoring up-loop data on its receiver data input. The ADLC can recognize the necessary sequences in the data stream to automatically go on/off the loop and to insert its own station data. The procedure is the following and is summarized in Table 1.

(1) **Go On-Loop** — When the ADLC powers up, the terminal station will be off line. The first task is to become an active terminal on the loop. The ADLC must be connected to a Loop Link via an external switch as shown in Figure 9a. After a hardware reset, the ADLC $\overline{\text{LOC}}/\text{DTR}$ Output will be in the high state and the up-loop receive data repeated

through gate A to the down Loop stations. Any Up-Loop transmission will be received by the ADLC. The Loop Mode/Non-Loop Mode Control bit (bit 5 in Control Register 3) must be set to place the ADLC in the Loop Mode. The ADLC now monitors its Rx Data input for a string of seven consecutive "1's" which will allow a station to go on line. The Loop operation may be monitored by use of the Loop Status bit in Status Register 1. After power up and reset, this bit is a zero. When seven consecutive "1's" are received by the ADLC the $\overline{\text{LOC}}/\text{DTR}$ output will go to a low level, disabling gate A (refer to Figure 9b), enabling gate B and connecting the ADLC Tx Data output to the down Loop stations. The up Loop data is now repeated to the down Loop stations via the ADLC. A 1-bit delay is inserted in the data (in NRZI mode, there will be a 2-bit delay) as it circulates through the ADLC. The ADLC is now on-line and the Loop Status bit in Status Register 1 will be at a one.

(2) **Go Active after Poll** — The receiver section will monitor the up-link data for a general or addressed poll command and the Tx FIFO should be loaded with data so that when the go ahead sequence of a zero followed by seven "1's" (01111111...) is detected, transmission can be initiated immediately. When the polling frame is detected, the Go-Active-On-Poll control bit must be set (bit 6 in Control

TABLE 1 -- SUMMARY OF LOOP MODE OPERATION

STATE	RX SECTION	TX SECTION	LOOP STATUS BIT
OFF-LOOP	Rx section receives data from loop and searches for 7 "1's" (when On-Loop Control bit set) to go ON-LOOP.	Inactive 1) NRZ MODE. Tx data output is maintained "high" (mark). 2) NRZI MODE. Tx data output reflects the Rx data input state delayed one bit time. (Not normally connected to loop.) The NRZI data is internally decoded to provide error-free transitions to On-Loop mode.	"0"
ON-LOOP	1) When Go-Active on poll bit is set, Rx section searches for 01111111 pattern (the EOP or "Go Ahead") to become the active terminal on the loop. 2) When On-Loop control bit is reset, Rx section searches for 8 "1's" to go OFF-Loop.	Inactive 1) NRZ MODE. Tx data output reflects Rx data input state delayed one bit time. 2) NRZI MODE. Tx data output reflects Rx data input state delayed 2 bit times.	"1"
ACTIVE	Rx section searches for flag (an interrupt from the loop controller) at Rx data input. Received flag causes FD output to go low. IRQ is generated if RIE and FDSE control bits are set.	Tx data originates within ADLC until Go Active on Poll bit is reset and a flag or Abort is completed. Then returns to ON-Loop state.	"0"

Register 3). A maximum of seven bit times are available to set this control bit after the closing flag of the poll. When the Go-Ahead is detected by the receiver, the ADLC will automatically change the seventh one to a zero so that the repeated sequence out gate B in Figure 9b is now an opening flag sequence (01111110). Transmission now continues from the Tx FIFO with data (address, control, etc.) as previously described. When the ADLC has gone active-on-poll, the Loop Status bit in Status Register 1 will go to a zero. The receiver searches for a flag, which indicates that the primary station is interrupting the current operation.

(3) Go Inactive when On-Loop — The Go-Active-On-Poll control bit may be RESET at any time during transmission. When the frame is complete (the closing Flag or abort is transmitted), the Loop is automatically released and the station reverts back to being just a 1-bit delay in the Loop, repeating up-link data. If the Go-Active-On-Poll control bit is not reset by software and the final frame is transmitted (Flag/Mark Idle bit=0), then the transmitter will mark idle and will not release the loop to up-loop data. A Tx Abort command would have to be used in this case in order to go inactive when on the loop. Also, if the Tx FIFO was not preloaded with data (address, control, etc.) prior to changing the "Go Ahead Character" to a Flag, the ADLC will either transmit flags (active idle character) until data is loaded (when Flag/Mark Idle Control bit is high) or will go into an underrun condition and transmit an Abort (when Flag/Mark Idle control bit is low). When an abort is transmitted, the Go-Active-on-Poll control bit is reset automatically and the ADLC reverts to its repeating mode, (TxD = delayed RxD). When the ADLC transmitter lets go of the loop, the Loop Status bit will return to a "1", indicating normal on-loop retransmission of up-loop data.

(4) Go Off-Loop — The ADLC can drop off the Loop (go off-line) similar to the way it went on-line. When the Loop On-Line control bit is reset the ADLC receiver section looks for eight successive "1's" before allowing the LOC/DTR output to return high (the inactive state). Gate A in Figure 9b will be enabled and gate B disabled allowing the loop to maintain continuity without disturbance. The Loop Status bit will show an off-line condition (logical zero).

SIGNAL DESCRIPTIONS

All inputs of ADLC are high-impedance and TTL-compatible level inputs. All outputs of the ADLC are compatible with standard TTL. Interrupt Request (IRQ), however, is an open-drain output (no internal pullup).

INTERFACE FOR MPU

Bidirectional Data Bus (D0-D7) — These data bus I/O ports allow the data transfer between ADLC and system bus. The data bus drivers are three-state devices that remain in the high-impedance (off) state except when the MPU performs an ADLC read operation.

Enable Clock (E) — E activates the address inputs (\overline{CS} , RS0, and RS1) and R/ \overline{W} input and enables the data transfer on the data bus. E also moves data through the Tx FIFO and Rx FIFO. E should be a free-running clock such as the E F6800 MPU system clock.

Chip Select (\overline{CS}) — An ADLC read or write operation is enabled only when the \overline{CS} input is low and the E clock input is high. (E • \overline{CS}).

PERIPHERAL/MODEM CONTROL

Register Selects (RS0, RS1) — When the Register Select inputs are enabled by (E+CS), they select internal registers in conjunction with the Read/Write input and Address Control bit (control register 1, bit 0). Register addressing is defined in Table 2.

Read/Write Control Line (R/W) — The R/W input controls the direction of data flow on the data bus when it is enabled by (E+CS). When R/W is high, the I/O Buffer acts as an output driver and as an input buffer when low. It also selects the Read Only and Write Only registers within the ADLC.

Reset Input (RESET) — The RESET input provides a means of resetting the ADLC from a hardware source. In the "low state," the RESET input causes the following:

- Rx Reset and Tx Reset are SET causing both the Receiver and Transmitter sections to be held in a reset condition.
- Resets the following control bits: Transmit Abort, RTS, Loop Mode, and Loop On-Line/DTR.
- Clears all stored status condition of the status registers.
- Outputs: RTS and LOC/DTR go high. TxD goes to the mark state ("1's" are transmitted).

When RESET returns "high" (the inactive state) the transmitter and receiver sections will remain in the reset state until Tx Reset and Rx Reset are cleared via the data bus under software control. The Control Register bits affected by RESET cannot be changed when RESET is "low."

Interrupt Request Output (IRQ) — IRQ will be low if an interrupt situation exists and the appropriate interrupt enable has been set. The interrupt remains as long as the cause for the interrupt is present and the enable is set. IRQ will be low as long as the IRQ status bit is set and is high if the IRQ status bit is not set.

CLOCK AND DATA OF TRANSMITTER AND RECEIVER

Transmitter Clock Input (TxC) — The transmitter shifts data on the negative transition of the TxC clock input. When the Loop Mode or Test Mode is selected, TxC should be the same frequency and phase as the RxC clock. The data rate of the transmitter should not exceed the E frequency.

Receiver Clock Input (RxC) — The receiver samples the data on the positive transition of the RxC clock. RxC should be synchronized with receive data externally.

Transmit Data Output (TxD) — The serial data from the transmitter is coded in NRZ or NRZI (Zero Complement) data format.

Receiver Data Input (RxD) — The serial data to be received by the ADLC can be coded in NRZ or NRZI (Zero Complement) data format. The data rate of the receiver should not exceed the E frequency. If a partial byte reception is possible at the end of a frame, the maximum data rate of the receiver is indicated by the following relationship:

$$f_{RxC} \leq \frac{1}{2t_E + 300 \text{ ns}}$$

where t_E is the period of E.

Request-to-Send Output (RTS) — The Request-to-Send output is controlled by the Request-to-Send control bit in conjunction with the state of the transmitter section. When the RTS bit goes high, the RTS output is forced low. When the RTS bit returns low, the RTS output remains low until the end of the frame and there is no further data in the Tx FIFO for a new frame. The positive transition of RTS occurs after the completion of a Flag, an Abort, or when the RTS control bit is reset during a mark idling state. When the RESET input is low, the RTS output goes high.

Clear-to-Send Input (CTS) — The CTS input provides a real-time inhibit to the TDRA status bit and its associated interrupt. The positive transition of CTS is stored within the ADLC to ensure its occurrence will be acknowledged by the system. The stored CTS information and its associated IRQ (if enabled) are cleared by writing a "1" in the Clear Tx Status bit or in the Transmitter Reset bit.

Data-Carrier-Detect Input (DCD) — The DCD input provides a real-time inhibit to the receiver section. A high level on the DCD input resets and inhibits the receiver register, but data in the Rx FIFO from a previous frame is not disturbed. The positive transition of DCD is stored within the ADLC to ensure that its occurrence will be acknowledged by the system. The stored DCD information and its associated IRQ (if enabled) are cleared by means of the Clear Rx Status Control bit or by the Rx Reset bit.

Loop On-Line Control/Data Terminal Ready Output (LOC/DTR) — The LOC/DTR output serves as a DTR output in the non-loop mode or as a Loop Control output in the loop mode. When LOC/DTR output performs the DTR function, it is turned on and off by means of the LOC/DTR control bit. When the LOC/DTR control bit is high the DTR output will be low. In the loop mode the LOC/DTR output provides the means of controlling the external loop interface hardware to go On-line or Off-line. When the LOC/DTR control bit is SET and the loop has "idled" for 7 bit times or more (RxD=0111111...), the LOC/DTR output will go low (on-line). The RESET input being low will cause the LOC/DTR output to be high.

Flag Detect Output (FD) — An output to indicate the reception of a flag and initiate an external time-out counter for the loop mode operation. The FD output goes low for 1 bit time beginning at the last bit of the flag character, as sampled by the receiver clock (RxC).

DMA INTERFACE

Receiver Data Service Request Output (RDSR) — The RDSR Output is provided primarily for use in DMA Mode operation and indicates (when high) that the Rx FIFO requests service (RDSR output reflects the RDA status bit regardless of the state of the RDSR mode control bit in CR1). If the prioritized Status Mode is selected, RDSR will be inhibited when any other receiver status conditions are present. RDSR goes low when the Rx FIFO is read.

Transmitter Data Service Request Output (TDSR) – The TDSR Output is provided for DMA mode operation and indicates (when high) that the Tx FIFO request service regardless of the state of the TDSR Mode Control bit in CR1. TDSR goes low when the Tx FIFO is loaded. TDSR is inhibited by: the Tx RS control bit being SET, RESET being low, or CTS being high. If the prioritized status mode is used, Tx Underrun also inhibits TDSR. TDSR reflects the TDRA status bit except in the FC mode. In the FC mode the TDSR line is inhibited.

ADLC REGISTERS

Eight registers in the ADLC can be accessed by means of the MPU data and address buses. The registers are defined as read-only or write-only according to the direction of information flow. The addresses of these registers are defined in Table 2. The transmitter FIFO register can be accessed by two different addresses, the "Frame Terminate" address and the "Frame Continue" address. (The function of these addresses are discussed in the FIFO section.)

TABLE 2 – REGISTER ADDRESSING

Register Selected	R/W	RS1	RS0	Address Control Bit (C1b0)
Write Control Register #1	0	0	0	X
Write Control Register #2	0	0	1	0
Write Control Register #3	0	0	1	1
Write Transmit FIFO (Frame Continue)	0	1	0	X
Write Transmit FIFO (Frame Terminate)	0	1	1	0
Write Control Register #4	0	1	1	1
Read Status Register #1	1	0	0	X
Read Status Register #2	1	0	1	X
Read Receiver FIFO	1	1	X	X

RECEIVER DATA FIRST-IN FIRST-OUT REGISTER

Rx FIFO – The Rx FIFO consists of three 8-bit registers which are used for the buffer storage of received data. Data bytes are always transferred from a full register to an adjacent empty register; and both phases of the E input clock are

used for the data transfer. Each register has pointer bits which point the frame boundary. When these pointers appear at the last FIFO location, they update the Address Present, Frame Valid, or FCS/IF Error status bits.

The RDA status bit indicates the state of the Rx FIFO. When RDA status bit is "1", the Rx FIFO is ready to be read. The RDA status is controlled by the 2-Byte/1-Byte control bit. When overrun occurs, the data in the first byte of the Rx FIFO are not longer valid.

Both the Rx Reset bit and RESET input clear the Rx FIFO Abort ("in Frame") and a high level on the DCD input also clears the Rx FIFO, but the last bytes of the previous frame, which are separated by the frame boundary pointer, are not disturbed.

TRANSMITTER DATA FIRST-IN FIRST-OUT REGISTER

Tx FIFO – The Tx FIFO consists of three 8-bit registers which are used for buffer storage of data to be transmitted. Data is always transferred from a full register to an empty adjacent register; the transfer occurs on both phases of the E input clock. The Tx FIFO can be addressed by two different register addresses, the "Frame Continue" address and the "Frame Terminate" address. Each register has pointer bits which point to the frame boundary. When a data byte is written at the "Frame Continue" address, the pointer of the first FIFO register is set. When a data byte is written at the "Frame Terminate" address, the pointer of the first FIFO register is reset. Rx RS control bit or Tx Abort control bit resets all pointers. The pointer will shift through the FIFO. When a positive transition is detected at the third location of FIFO, the transmitter initiates a frame with an open flag. When the negative transition is detected at the third location of FIFO, the transmitter closes a frame, appending the FCS and closing Flag to the last byte.

The Tx last control bit can be used instead of using the "Frame Terminate" address. When the Tx last control bit is set with a "1", the logic searches the last byte location in the FIFO and resets the pointer in the FIFO register.

The status of Tx FIFO is indicated by the TDRA status bit. When TDRA is "1", the Tx FIFO is available for loading data. The TDRA status is controlled by the 2-Byte/1-Byte control bit. The Tx FIFO is reset by both Tx Reset and RESET input. During this reset condition or when CTS input is high, the TDRA status bit is suppressed and data loading is inhibited.

ADLC INTERNAL REGISTER STRUCTURE

	Bit #	RS1 RS0 = 00	RS1 RS0 = 01	RS1 RS0 = 10	RS1 RS0 = 11
		Status Register #1	Status Register #2	Receiver Data Register	
Read Only Registers	0	RDA	Address Present	Bit 0	Same as RS1, RS0 = 10
	1	Status #2 Read Request	Frame Valid	Bit 1	
	2	Loop	Inactive Idle Received	Bit 2	
	3	Flag Detected (When Enabled)	Abort Received	Bit 3	
	4	CTS	FCS Error	Bit 4	
	5	Tx Underrun	DCD	Bit 5	
	6	TDRA/Frame Complete	Rx Overrun	Bit 6	
	7	IRQ Present	RDA (Receiver Data Available)	Bit 7	

	Bit #	Control Register #1	Control Register #2 (C ₁ b ₀ = 0)	Control Register #3 (C ₁ b ₀ = 1)	Transmitter Data (Continue Data)	Transmitter Data (Last Data) (C ₁ b ₀ = 0)	Control Register #4 (C ₁ b ₀ = 1)
		Write Only Registers	0	Address Control (AC)	Prioritized Status Enable	Logical Control Field Select	Bit 0
1	Receiver Interrupt Enable (RIE)		2 Byte/1 Byte Transfer	Extended Control Field Select	Bit 1	Bit 1	Word Length Select Transmit #1
2	Transmitter Interrupt Enable (TIE)		Flag/Mark Idle	Auto, Address Extension Mode	Bit 2	Bit 2	Word Length Select Transmit #2
3	RDSR Mode (DMA)		Frame Complete/ TDRA Select	01/11 Idle	Bit 3	Bit 3	Word Length Select Receive #1
4	TDSR Mode (DMA)		Transmit Last Data	Flag Detected Status Enable	Bit 4	Bit 4	Word Length Select Receive #2
5	Rx Frame Discontinue		CLR Rx Status	Loop/Non-Loop Mode	Bit 5	Bit 5	Transmit Abort
6	Rx RESET		CLR Tx Status	Go Active on Poll/Test	Bit 6	Bit 6	Abort Extend
7	Tx RESET		RTS Control	Loop On-Line Control DTR	Bit 7	Bit 7	NRZI/NRZ

CONTROL REGISTERS

CONTROL REGISTER 1 (CR1)

RS1	RS0	R/W	AC	7	6	5	4
0	0	0	X	TxRS	RxRS	Discontinue	TDSR Mode
							3
							RDSR Mode
							2
							TIE
							1
							RIE
							0
							AC

b0 — Address Control (AC) — AC provides another RS (Register Select) signal internally. The AC bit is used in conjunction with RS0, RS1, and R/W inputs to select particular registers, as shown in Table 2.

b1 — Receiver Interrupt Enable (RIE) — RIE enables/disables the interrupt request caused by the receiver section. 1...enable, 0...disable.

b2 — Transmitter Interrupt Enable (TIE) — TIE enables/disables the interrupt request caused by the transmitter. 1...enable, 0...disable.

b3 — Receiver Data Service Request Mode (RDSR MODE) — The RDSR MODE bit provides the capability of operation with a bus system in the DMA mode when used in conjunction with the prioritized status mode. When RDSR MODE is set, an interrupt request caused by RDA status is inhibited, and the ADLC does not request data transfer via the $\overline{\text{IRQ}}$ output.

b4 — Transmitter Data Service Request Mode (TDSR MODE) — The TDSR MODE bit provides the capability of operation with a bus system in the DMA mode when used in conjunction with the prioritized status mode. When TDSR MODE is set, an interrupt request caused by TDRA status is inhibited, and the ADLC does not request a data transfer via the $\overline{\text{IRQ}}$ output.

b5 — Rx Frame Discontinue (DISCONTINUE) — When the DISCONTINUE bit is set, the currently received frame is ignored and the ADLC discards the data of the current frame. The DISCONTINUE bit only discontinues the currently received frame and has no effect on subsequent frames, even if a following frame has entered the receiver section. The DISCONTINUE bit is automatically reset when the last byte of the frame is discarded. When the ignored frame is aborted by receiving an Abort or DCD failure, the DISCONTINUE bit is also reset.

b6 — Receiver Reset (Rx RS) — When the Rx RS bit is "1", the receiver section stays in the reset condition. All receiver sections, including the Rx FIFO register and the receiver status bits in both status registers, are reset. (During reset, the stored DCD status is reset but the DCD status bit follows the $\overline{\text{DCD}}$ input.) Rx RS is set by forcing a low level on the $\overline{\text{RESET}}$ input or by writing a "1" into the bit from the data bus. Rx RS must be reset by writing a "0" from the data bus after $\overline{\text{RESET}}$ has gone high.

b7 — Transmitter Reset (Tx RS) — When the Tx RS bit is "1", the transmitter section stays in the reset condition and transmits marks ("1"s"). All transmitter sections, including the Tx FIFO and the transmitter status bits, are reset (FIFO cannot be loaded). During reset, the stored CTS status is reset but the CTS status bit follows the $\overline{\text{CTS}}$ input. Tx RS is set by forcing a low level on the $\overline{\text{RESET}}$ input or by writing a "1" from the data bus. It must be reset by writing a "0" after $\overline{\text{RESET}}$ has gone high.

CONTROL REGISTER 2 (CR2)

	7	6	5	4	3	2	1	0
RS1	RTS	CLR	CLR	Tx	FC/TDRA	F/M	2/1	PSE
RS0		TxST	RxST	Last	Select	Idle	Byte	
R/W								
AC								
	0	1	0	0				

b0 — Prioritized Status Enable (PSE) — When the PSE bit is SET, the status bits in both status registers are prioritized as defined in the Status Register section. When PSE is low, the status bits indicate current status without bit suppression by other status bits. The exception to this rule is the \overline{CTS} status bit which always suppresses the TDRA status.

b1 — 2-Byte/1-Byte Transfer (2/1 Byte) — When the 2/1 Byte bit is RESET the TDRA and RDA status bits then will indicate the availability of their respective data FIFO registers for a single-byte data transfer. Similarly, if 2/1 Byte is set, the TDRA and RDA status bit indicate when two bytes of data can be moved without a second status read.

b2 — Flag/Mark Idle Select (F/M Idle) — The F/M Idle bit selects Flag characters or bit-by-bit Mark Idle for the time fill or the idle state of the transmitter. When Mark Idle is selected, Go-Ahead code can be generated for loop operation in conjunction with the 01/11 Idle control bit (C3b3). 1...Flag time fill, 0...Mark Idle.

b3 — Frame Complete/TDRA Select (FC/TDRA Select) — The FC/TDRA Select bit selects TDRA status or FC status for the TDRA/FC status bit indication. 1...FC status, 0...TDRA status.

b4 — Transmit Last Data (Tx Last) — Tx Last bit provides another method to terminate a frame. This bit should be set

after loading the last data byte and before the Tx FIFO empties. When the Tx Last bit is set, the ADLC assumes the byte is the last byte and terminates the frame by appending CRCC and a closing Flag. This control bit is useful for DMA operation. Tx Last bit automatically returns to the "0" state.

b5 — Clear Receiver Status (CLR Rx ST) — When a "1" is written into the CLR Rx ST bit, a reset signal is generated for the receiver status bits in status registers #1 and #2 (except AP and RDA bits). The reset signal is enabled only for the bits which have been present during the last "read status" operation. The CLR Rx ST bit automatically returns to the "0" state.

b6 — Clear Transmitter Status (CLR Tx ST) — When a "1" is written into CLR Tx ST bit, a reset signal is generated for the transmitter status bits in status register #1 (except TDRA). The reset signal is enabled for the bits which have been present during the last "read status" operation. The CLR Tx ST bit automatically returns to the "0" state.

b7 — Request-to-Send Control (RTS) — The RTS bit, when high, causes the \overline{RTS} output to be low (the active state). When the RTS bit returns low and data is being transmitted, the \overline{RTS} output remains low until the last character of the frame (the closing Flag or Abort) has been completed and the Tx FIFO is empty. If the transmitter is idling when the RTS bit returns low, the \overline{RTS} output will go high (the inactive state) within two bit times.

CONTROL REGISTER 3 (CR3)

RS1	RS0	R/W	AC	7	6	5	4	3	2	1	0
0	1	0	1	LOC/ DTR	GAP/ TST	Loop	FDSE	01/11 Idle	AEX	CEx	LCF

b0 — Logical Control Field Select (LCF) — The LCF select bit causes the first byte(s) of data belonging to the information field to remain 8-bit characters until the logical control field is complete. The logical control field (when selected) is an automatically extendable field which is extended when bit 7 of a logical control character is a "1." When the LCF Select bit is reset the ADLC assumes no logical control field is present for either the transmit or received data channels. When the logical control field is terminated, the word length of the information data is then defined by WLS₁ and WLS₂.

b1 — Extended Control Field Select (CEx) — When the CEx bit is a "1", the control field is extended and assumed to be 16 bits. When CEx is "0", the control field is assumed to be 8 bits.

b2 — Auto/Address Extend Mode (AEx) — The AEx bit when "low" allows full 8 bits of the address octet to be utilized for addressing because address extension is inhibited. When the AEx bit is "high," bit 0 of address octet equal to "0" causes the Address field to be extended by one octet. The exception to this automatic address field extension is when the first address octet is all "0's" (the Null Address).

b3 — 01/11 Idle (01/11 Idle) — The 01/11 Idle Control bit determines whether the inactive (Mark) idle condition begins with a "0" or not. If the 01/11 Idle Control is SET, the closing flag (or Abort) will be followed by a 011111... pattern. This is required of the controller for the "Go Ahead" character in the Loop Mode. When 01/11 is RESET, the idling condition will be all "1's".

b4 — Flag Detect Status Enable (FDSE) — The FDSE bit enables the FD status bit in Status Register #1 to indicate the occurrence of a received Flag character. The status indication will be accompanied by an interrupt if RIE is SET. Flag

detection will cause the Flag Detect output to go low for 1 bit time regardless of the state of FDSE.

b5 — LOOP/NON-LOOP Mode (LOOP) — When the LOOP bit is set, loop mode operation is selected and the GAP/TST control bit, LOC/DTR control bit and LOC/DTR output are selected to perform the loop control functions. When LOOP is reset, the ADLC operates in the point-to-point data communications mode.

b6 — Go Active On Poll/Test (GAP/TST) — *In the Loop Mode* — The GAP/TST bit is used to respond to the poll sequence and to begin transmission. When GAP/TST is set, the receiver searches for the "Go Ahead" (or End of Poll, EOP). The receiver "Go ahead" is converted to an opening flag and the ADLC starts its own transmission. When GAP/TST is reset during the transmission, the end of the frame (the completion of Flag or Abort) causes the termination of the "go-active-on-poll" operation and the Rx Data to Tx Data link is re-established. The ADLC then returns to the "loop-on-line" state.

In the Non-Loop Mode — The GAP/TST bit is used for self-test purposes. If GAP/TST bit is set, the TxD output is connected to the RxD input internally, and provides a "loop-back" feature. For normal operation, the GAP/TST bit should be reset.

b7 — Loop On-Line Control/DTR Control (LOC/DTR) — *In the Loop Mode* — The LOC/DTR bit is used to go on-line or to go off-line. When LOC/DTR is set, the ADLC goes to the on-line state after 7 consecutive "1's" occur at the RxD input. When LOC/DTR is reset, the ADLC goes to the "off-line" state after eight consecutive "1's" occur at the RxD input.

In the Non-Loop Mode — The LOC/DTR bit directly controls the Loop On-Line/DTR output state. 1...DTR output goes to low level, 0...DTR output goes to high level.

CONTROL REGISTER 4 (CR4)

				7	6	5	4	3	2	1	0
RS1	RS0	R/W	AC	NRZI/NRZ	ABT _{EX}	ABT	R _x		T _x		"FF"/F
1	1	0	1				WLS ₂	WLS ₁	WLS ₂	WLS ₁	

b0 — Double Flag/Single Flag Interframe Control ("FF"/"F") — The "FF"/"F" Control bit determines whether the transmitter will transmit separate closing and opening Flags when frames are transmitted successively. When the "FF"/"F" control bit is low, the closing flag of the first frame will serve as the opening flag of the second frame. When the bit is high, independent opening and closing flags will be transmitted.

b1, b2 — Transmitter Word Length Select (Tx WLS1 and WLS2) — Tx WLS1 and WLS2 are used to select the word length of the transmitter information field. The encoding format is shown in Table 3.

b3, b4 — Receiver Word Length Select (Rx WLS1 and WLS2) — Rx WLS1 and WLS2 are used to select the word length of the receiver information field. The encoding format is shown in Table 3.

TABLE 3 — I-FIELD CHARACTER LENGTH SELECT

WLS ₁	WLS ₂	I-Field Character Length
0	0	5 bits
1	0	6 bits
0	1	7 bits
1	1	8 bits

b5 — Transmit Abort (ABT) — The ABT bit causes an Abort (at least 8 bits of "1" in succession) to be transmitted. The Abort is initiated and the Tx FIFO is cleared when the control bit goes high. Once Abort begins, the Tx Abort control bit assumes the low state.

b6 — Abort Extend (ABT_{EX}) — If ABT_{EX} is set, the abort code initiated by ABT is extended up to at least 16 bits of consecutive "1's", the mark Idle State.

b7 — NRZI (Zero Complement)/NRZ Select (NRZI/NRZ) — NRZI/NRZ bit selects the transmit/receive data format to be NRZI or NRZ in both Loop Mode or Non-Loop mode operation. When the NRZI Mode is selected, a

1-bit delay is added to the transmitted data (TxD) to allow for NRZI encoding. 1...NRZI, 0...NRZ.

NOTE

NRZI coding — The serial data remains in the same state to send a binary "1" and switches to the opposite state to send a binary "0".

STATUS REGISTER

The Status Register #1 is the main status register. The IRQ bit indicates whether the ADLC requests service or not. The S2RQ bit indicates whether any bits in status register #2 request any service. TDRA and RDA, because they are most often used, are located in bit positions that are more convenient to test. RDA reflects the state of the RDA bit in status register #2.

The Status Register #2 provides the detailed status information contained in the S2RQ bit and these bits reflect receiver status. The FD bit is the only receiver status which is not indicated in status register #2.

The prioritized status mode provides maximum efficiency in searching the status bits and indicates only the most important action required to service the ADLC. The priority trees of both status registers are provided in Figure 10.

Reading the status register is a non-destructive process. The method of clearing status depends upon the bit's function and is discussed for each bit in the register.

FIGURE 10 — STATUS REGISTER PRIORITY TREE (PSE = 1)

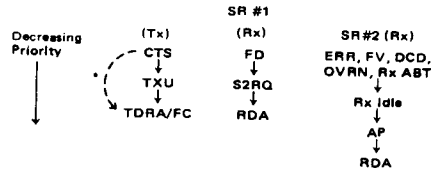

*Prioritized even when PSE = 0

NOTE: Status bit above will inhibit one below it.

STATUS REGISTER 1 (SR1)

RS1	RS0	R/W	AC	7	6	5	4	3	2	1	0
0	0	1	X	IRQ	TDRA/FC	TXU	CTS	FD	LOOP	S2RQ	RDA

b0 — Receiver Data Available (RDA) — The RDA status bit reflects the state of the RDA status bit in status register #2. It provides the means of achieving data transfers of received data in the full Duplex Mode without having to read both status registers.

b1 — Status Register #2 Read Request (S2RQ) — All the status bits (stored conditions) of status register #2, (except RDA bit) are logically ORed and indicated by the S2RQ status bit. Therefore, S2RQ indicates that status register #2 needs to be read. When S2RQ is "0", it is not necessary to read status register #2. The bit is cleared when the appropriate bits in status register #2 are cleared or when Rx Reset is used.

b2 — Loop Status (LOOP) — The LOOP status bit is used to monitor the loop operation of the ADLC. This bit does not cause an IRQ. When Non-Loop Mode is selected, LOOP bit stays "0". When Loop Mode is selected, the LOOP status bit goes to "1" during "On-Loop" condition. When ADLC is in an "Off-Loop" condition or "Go-Active-On-Poll" condition, the LOOP status bit is a "0".

b3 — Flag Detected (FD) — The FD Status bit indicates that a flag has been received if the Flag Detect Enable control bit has been set. The bit goes high at the last bit of the Flag Character received (when the Flag Detect Output goes low) and is stored until cleared by Clear Rx Status or Rx Reset.

b4 — Clear-to-Send (CTS) — The $\overline{\text{CTS}}$ input positive transition is stored in the status register and causes an IRQ (if Enabled). The stored CTS condition and its IRQ are cleared by Clear Tx Status control bit or Tx Reset bit. After the stored status is reset, the CTS status bit reflects the state of the $\overline{\text{CTS}}$ input.

b5 — Transmitter Underrun (TxU) — When the transmitter runs out of data during a frame transmission, an underrun occurs and the frame is automatically terminated by transmitting an Abort. The underrun condition is indicated by the TxU status bit. TxU can be cleared by means of the Clear Tx Status Control bit or by Tx Reset.

b6 — Transmitter Data Register Available/Frame Complete (TDRA/FC) — The TDRA Status bit serves two purposes depending upon the state of the Frame Complete/TDRA Select control bit. When this bit serves as a TDRA status bit, it indicates that data (to be transmitted) can be loaded into the Tx Data FIFO register. The first register (Register #1) of the Tx Data FIFO being empty (TDRA = "1") will be indicated by the TDRA Status bit in the "1-Byte Transfer Mode." The first two registers (Registers #1 and #2) must be empty for TDRA to be high when in the "2-Byte Transfer Mode." TDRA is inhibited by Tx Reset, or CTS being high.

When the Frame Complete Mode of operation is selected, the TDRA/FC status bit goes high when an abort is transmitted or when a flag is transmitted with no data in the Tx FIFO. The bit remains high until cleared by resetting the TDRA/FC control bit or setting the Tx Reset bit.

b7 — Interrupt Request (IRQ) — The Interrupt Request status bit indicates when the IRQ output is in the active state (IRQ Output = "0"). The IRQ status bit is subject to the same interrupt enables (RIE, TIE) as the $\overline{\text{IRQ}}$ output, i.e., with both transmitter and receiver interrupts enabled, the IRQ status bit is a logical ORed indication of Status Register 1 status bits. The IRQ bit only reflects the set status bits which have interrupts enabled. The IRQ status bit simplifies status inquiries for polling systems by providing single bit indication of service requests.

STATUS REGISTER 2 (SR2)

	7	6	5	4	3	2	1	0
RS1	RDA	OVRN	DCD	ERR	Rx	Rx	FV	AP
RS0					ABT	Idle		
R/W								
AC								
	0	1	1	X				

b0 — Address Present (AP) — The AP status bit provides the frame boundary and indicates an Address octet is available in the Rx Data FIFO register. In the Extended Addressing Mode, the AP bit continues to indicate addresses until the Address field is complete. The Address present status bit is cleared by reading data or by Rx Reset.

b1 — Frame Valid (FV) — The FV status bit provides the frame boundary indication to the MPU and also indicates that a frame is complete with no error. The FV status bit is set when the last data byte of a frame is transferred into the last location of the Rx FIFO (available to be read by MPU). Once FV status is set, the ADLC stops further data transfer into the last location of the Rx FIFO (in order to prevent the mixing of two frames) until the status bit is cleared by the Clear Rx Status bit or Rx Reset.

b2 — Inactive Idle Received (Rx Idle) — The Rx Idle status bit indicates that a minimum of 15 consecutive "1's" have been received. The event is stored within the status register and can cause an interrupt. The interrupt and stored condition are cleared by the Clear Rx Status Control bit. The Status bit is the Logical OR of the receiver idling detector (which continues to reflect idling until a "0" is received) and the stored inactive idle condition.

b3 — Abort Received (RxABT) — The RxABT status bit indicates that seven or more consecutive "1's" have been received. Abort has no meaning under out-of-frame conditions; therefore, no interrupt nor storing of the status will occur unless a Flag has been detected prior to the Abort. An Abort Received when "in frame" is stored in the status register and causes an IRQ. The status bit is the logical OR of the stored conditions and the Rx Abort detect logic, which is cleared after 15 consecutive "1's" have occurred. The stored

Abort condition is cleared by the Clear Rx Status Control bit or Rx Reset.

b4 — Frame Check Sequence/Invalid Frame Error (ERR) — When a frame is complete with a cyclic redundancy check (CRC) error or a short frame error (the frame does not have complete Address and Control fields), the ERR status bit is set instead of the Frame Valid status bit. Other functions, frame boundary indication and control function, are exactly the same as for the Frame Valid status bit. Refer to the FV status bit.

b5 — Data Carrier Detect (DCD) — A positive transition on the DCD input is stored in the status register and causes an IRQ (if enabled). The stored DCD condition and its IRQ are cleared by the Clear Rx Status Control bit or Rx Reset. After stored status is reset, the DCD status bit follows the state of the input. Both the stored DCD condition and the DCD input cause the reset of the receiver section when they are high.

b6 — Receiver Overrun (OVRN) — OVRN status indicates that receiver data has been transferred into the Rx FIFO when it is full, resulting in data loss. The OVRN status is cleared by the Clear Rx Status bit or Rx Reset. Continued overrunning only destroys data in the first FIFO Register.

b7 — Receiver Data Available (RDA) — The Receiver Data Available status bit indicates when receiver data can be read from the Rx Data FIFO. When the prioritized status mode is used, the RDA bit indicates that non-address and non-last data are available in the Rx FIFO. The receiver data being present in the last register of the FIFO causes RDA to be high for the "1-Byte Transfer Mode." The RDA bit being high indicates that the last two registers are full when in the "2-Byte Transfer Mode." The RDA status bit is reset automatically when data is not available.

PROGRAMMING CONSIDERATIONS

1. **Status Priority** — When the prioritized status mode is used, it is best to test for the lowest priority conditions first. The lowest priority conditions typically occur more frequently and are the most likely conditions to exist when the processor is interrupted.
2. **Stored vs Present Status** — Certain status bits (DCD, CTS, Rx Abort, and Rx Idle) indicate a status which is the logical OR of a stored and a present condition. It is the stored status that causes an interrupt and which is cleared by a Status Clear control bit. After being cleared, the status register will reflect the present condition of an input or a receiver input sequence.
3. **Clearing Status Registers** — In order to clear an interrupt with the two Status Clear control bits, a particular status condition must be read before it can be cleared. In the prioritized mode, clearing a higher priority condition might result in another IRQ caused by a lower priority condition whose status was suppressed when a status register was first read. This guarantees that a status condition is never inadvertently cleared.
4. **Clearing the Rx FIFO** — An Rx Reset will effectively clear the contents of all three Rx FIFO bytes. However, the FIFO may contain data from two different frames when abort or DCD failure occurs. When this happens, the data from a previously closed frame (a frame whose closing flag has been received) will not be destroyed.
5. **Servicing the Rx FIFO in a 2-Byte Mode** — The procedure for reading the last bytes of data is the same, regardless of whether the frame contains an even or an odd number of bytes. Continue to read 2 bytes until an interrupt occurs that is caused by an end-of-frame status (FV or ERR). When this occurs, indicating the last byte either has been read or is ready to be read, switch temporarily to the 1-byte mode with no prioritized status (control register 2).

Test RDA to indicate whether a 1-byte read should be performed. Then clear the frame end status.

6. **Frame Complete Status and RTS Release** — In many cases, a MODEM will require a delay for releasing RTS. An 8-bit or 16-bit delay can be added to the ADLC RTS output by using an Abort. At the end of a transmission, frame complete status will indicate the frame completion. After frame complete status goes high, write "1" into the Abt control bit (and Abt Extend bit if a 16-bit delay is required). After the Abt control bit is set, write "0" into the RTS control bit. The transmitter will transmit eight or sixteen "1's" and the RTS output will then go high (inactive).
7. **Note to users not using the EF6800** — (a) Carte should be taken when performing a write followed by a read on successive E pulses at a high frequency rate. Time must be allowed for status changes to occur. If this is done, the time that E is low between successive write/read E pulses should be at least 500 ns. (b) The ADLC is a completely static part. However, the E frequency should be high enough to move data through the FIFOs and to service the peripheral requirements. Also, the period between successive E pulses should be less than the period of Rx C or Tx C in order to maintain synchronization between the data bus and the peripherals.
8. **Clear-to-Send (CTS)** — The CTS input, when high, provides a real-time inhibit to the TDRA status bit and its associated interrupt. All other status bits will be operational. Since it inhibits TDRA, CTS also inhibits the TDSR DMA request. The CTS input being high does not affect any other part of the transmitter. Information in the Tx FIFO and Tx Shift Register will, therefore, continue to be transmitted as long as the Tx CLK is running.

ORDERING INFORMATION

<div style="display: flex; justify-content: space-around; align-items: center;"> EF68A54 C M B/B </div>												
Device					Screening level							
Package					Oper. temp.							
The table below horizontally shows all available suffix combinations for package, operating temperature and screening level. Other possibilities on request.												
DEVICE	PACKAGE					OPER. TEMP.			SCREENING LEVEL			
	C	J	P	E	FN	L*	V	M	Std	D	G/B	B/B
EF6854 (1.0 MHz)	●				●	●			●			
		●					●		●			
	●			●				●	●		●	●
		●						●	●		●	
EF68A54 (1.5 MHz)	●					●			●			
	●	●					●		●			
	●		●					●	●		●	●
		●						●	●		●	
EF68B54 (2.0 MHz)	●					●			●			
	●	●					●		●		●	
Examples : EF6854C, EF6854CV, EF6854CM, EF6854JM												
Package : C : Ceramic DIL, J : Cerdip DIL, P : Plastic DIL, E : LCCC, FN : PLCC. Oper. temp. : L* : 0°C to +70°C, V : -40°C to +85°C, M : -55°C to +125°C, * : may be omitted. Screening level : Std : (no-end suffix), D : NFC 96883 level D, G/B : NFC 96883 level G, B/B : NFC 96883 level B and MIL-STD-883C level B.												

PHYSICAL DIMENSIONS

CB-132

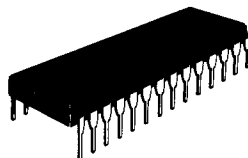

P SUFFIX
PLASTIC PACKAGE

ALSO AVAILABLE

J SUFFIX
CERDIP PACKAGE

C SUFFIX
CERAMIC PACKAGE

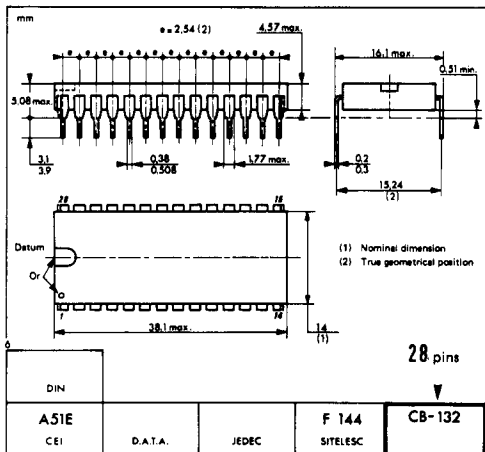

CB-520



**FN SUFFIX
PLCC 28**

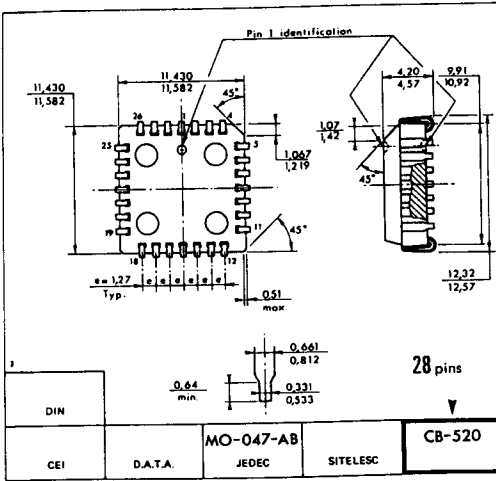

CB-707



**E SUFFIX
LCCC 28**

