

DESCRIPTION

These improved full adders perform the addition of two 4-bit binary numbers. The sum (Σ) outputs are provided for each bit, and the resultant carry (C4) is obtained from the fourth bit. These adders feature full internal look ahead across all four bits generating the carry term in ten nano-seconds typically. This provides the system designer with partial look-ahead performance at the economy and reduced package count of a ripple-carry implementation.

The adder logic, including the carry, is implemented in its true form meaning that the end-around carry can be accomplished without the need for logic or level inversion.

The LS83A and the LS283 are identical in performance; only the pin out is different. They are designed to replace the 5483A and the 54283 respectively. The LS283 is recommended for new designs. V_{CC} and ground on corner pins simplify board layout.

PIN-OUT DIAGRAMS

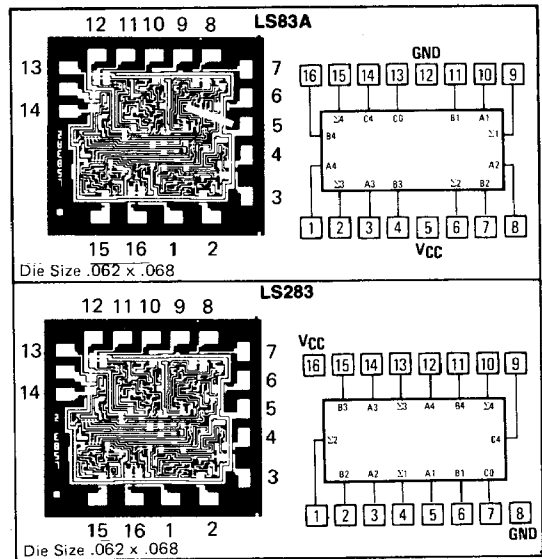

LOGIC DIAGRAM

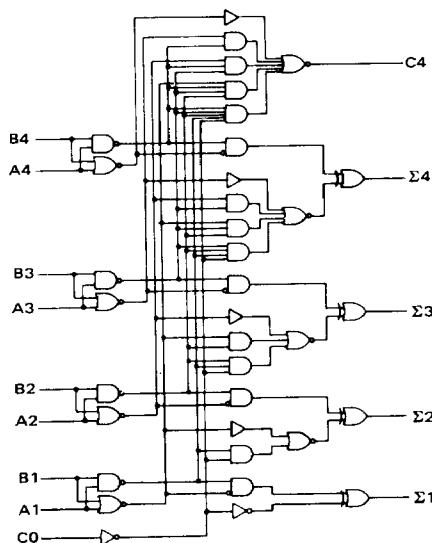

FUNCTION TABLE

INPUT		OUTPUT								
		WHEN C0 = L			WHEN C0 = H			WHEN C2 = H		
		WHEN C2 = L	WHEN C2 = L	WHEN C2 = H	WHEN C2 = L	WHEN C2 = L	WHEN C2 = H	WHEN C2 = L	WHEN C2 = L	WHEN C2 = H
A1	B1	A2	B2	$\Sigma 1$	$\Sigma 2$	C2	$\Sigma 1$	$\Sigma 2$	C2	
A3	B3	A4	B4	$\Sigma 3$	$\Sigma 4$	C4	$\Sigma 3$	$\Sigma 4$	C4	
L	L	L	L	L	L	L	H	L	L	
H	L	L	L	H	L	L	L	H	L	
L	H	L	L	H	L	L	L	H	L	
H	H	L	L	L	H	L	H	H	L	
L	L	H	L	L	H	L	H	H	L	
H	L	H	L	H	L	L	L	L	H	
L	H	H	L	H	L	L	L	L	H	
H	H	H	L	L	L	H	H	L	H	
L	L	L	H	L	H	L	L	H	L	
H	L	L	H	L	L	L	H	H	L	
L	L	H	H	L	L	H	L	L	H	
H	L	H	H	L	L	H	L	H	H	
L	H	H	H	L	L	H	L	H	H	
H	H	H	H	H	L	H	H	H	H	

H = high level, L = low level

NOTE:

Input conditions at A1, B1, A2, B2, and C0 are used to determine outputs $\Sigma 1$ and $\Sigma 2$ and the value of the internal carry C2. The values at C2, A3, B3, A4, and B4 are then used to determine outputs $\Sigma 3$, $\Sigma 4$, and C4.

Recommended Operating Conditions

	9LS/54LS			9LS/74LS			Unit
	Min	Nom	Max	Min	Nom	Max	
Supply voltage, V_{CC}	4.5	5	5.5	4.75	5	5.25	V
High-level output current, I_{OH}			-400			-400	μ A
Low-level output current, I_{OL}			4			8	mA
Operating free-air temperature, T_A	-55		125	0		70	$^{\circ}$ C

Electrical Characteristics Over Recommended Free-Air Temperature Range (Unless Otherwise Noted)

Parameter	Test Conditions*	9LS/54LS			9LS/74LS			Unit
		Min	Typ**	Max	Min	Typ**	Max	
V_{IH}		2			2			V
V_{IL}				0.7			0.8	V
V_i	$V_{CC} = \text{MIN}, I_i = -18\text{mA}$			-1.5			-1.5	V
V_{OH}	$V_{CC} = \text{MIN}, V_{IH} = 2\text{V}$ $V_{IL} = V_{IL\text{max}}, I_{OH} = -400\mu\text{A}$	2.5	3.4		2.7	3.4		V
V_{OL}	$V_{CC} = \text{MIN}, V_{IH} = 2\text{V},$ $V_{IL} = V_{IL\text{max}}$		0.25	0.4		0.25	0.4	V
I_i Any A or B C0	$V_{CC} = \text{MAX}, V_i = 7\text{V}$			0.2			0.2	mA
				0.1			0.1	
I_{IH} Any A or B C0	$V_{CC} = \text{MAX}, V_i = 2.7\text{V}$			40			40	μ A
				20			20	
I_{IL} Any A or B C0	$V_{CC} = \text{MAX}, V_i = 0.4\text{V}$			-0.8			-0.8	mA
				-0.4			-0.4	
$I_{os}\dagger$	$V_{CC} = \text{MAX}$	-15		-100	-15		-100	mA
I_{CC}	$V_{CC} = \text{MAX},$ Outputs open	All inputs grounded	22	39	22	39	mA	
		All B low, other inputs at 4.5V	19	34	19	34		
		All inputs at 4.5V	19	34	19	34		

*For conditions shown as MIN or MAX, use the appropriate value specified under recommended operating conditions for the applicable device type.

**All typical values are at $V_{CC} = 5\text{V}, T_A = 25^{\circ}\text{C}$.

†Not more than one output should be shorted at a time.

Switching Characteristics, $V_{CC} = 5\text{V}$ Over Recommended Free-Air Temperature Range

Parameter	From (input)	To (output)	-55°C			$+25^{\circ}\text{C}$			$+125^{\circ}\text{C}$			Unit
			Min	Typ	Max	Min	Typ	Max	Min	Typ	Max	
Test Conditions: $C_L = 15\text{pF}, R_L = 2\text{k}\Omega$ (See Fig. A, page 2-174)												
t_{PLH}	C0	Any Σ		15	20		14	19		15	21	ns
t_{PHL}				15	21		16	22		20	27	
t_{PLH}	A_i or B_i	Σ_i		20	30		18	24		21	27	ns
t_{PHL}				19	29		15	24		17	25	
t_{PLH}	C0	C4		9	14		7	12		11	18	ns
t_{PHL}				9	14		9	13		11	16	
t_{PLH}	A_i or B_i	C4		9	15		8	13		11	17	ns
t_{PHL}				10	14		9	14		11	16	
Test Conditions: $C_L = 50\text{pF}, R_L = 2\text{k}\Omega$ (See Fig. A, page 2-174)												
t_{PLH}	C0	Any Σ		16	21		15	20		17	22	ns
t_{PHL}				19	25		19	25		25	30	
t_{PLH}	A_i or B_i	Σ_i		25	32		18	26		25	32	ns
t_{PHL}				24	30		18	26		25	31	
t_{PLH}	C0	C4		11	16		10	15		12	19	ns
t_{PHL}				12	17		10	16		13	18	
t_{PLH}	A_i or B_i	C4		11	17		10	15		13	19	ns
t_{PHL}				13	18		12	16		14	20	

NOTE: AC specification shown under -55°C and $+125^{\circ}\text{C}$ are for 9LS devices only. All 50pF specifications are for 9LS only.