



Le79R70

Ringing Subscriber Line Interface Circuit VE580 Series

APPLICATIONS

- Integrated Access Devices (IADs)
- Network Interface Units (NIUs)
- Cable Modems
- DSL Modems
- Set Top / House Side Boxes
- Intelligent PBX
- Pain Gain
- FXS Cards
- Voice over ISDN or T1/E1
- Smart Residential Gateways
- WLL, APON, FITL, NGN, and all other short-loop CPE/Enterprise telephony applications

FEATURES

- Ideal for ISDN-TA and set top applications
- On-chip ringing with on-chip ring-trip detector
- Low Standby state power
- Battery operation:
 - VBAT1: -40 V to -67 V
 - VBAT2: -19 V to VBAT1
- On-chip battery switching and feed selection
- On-hook transmission
- Polarity reversal option
- Programmable constant-current feed
- Programmable open circuit voltage
- Programmable loop-detect threshold
- Current gain = 1000
- Two-wire impedance set by single component
- Ground-key detector
- Tip Open state for ground-start lines
- Internal VEE regulator (no external -5 V power supply required)
- Two on-chip relay drivers and snubber circuits
- Space-saving package options (8x8 QFN)

RELATED LITERATURE

- 080917 VE790 Series RSLIC Device Product Brief
- 080158 Le79R70/79/100/101 Ringing SLIC Devices Technical Overview
- 080255 Le71HE0040J Evaluation Board User's Guide
- 080753 Le58QL02/021/031 QL5LAC™ Data Sheet

ORDERING INFORMATION

Device ¹	Package Type ^{2, 3}	Packing ⁵
Le79R70JC	32-pin PLCC, No Pol. Rev.	Tube
Le79R70DJC	32-pin PLCC, No Pol. Rev. (Green package)	Tube
Le79R70-1JC	32-pin PLCC, Pol. Rev.	Tube
Le79R70-1DJC	32-pin PLCC, Pol. Rev. (Green package)	Tube
Le79R70QC	32-pin QFN, No Pol. Rev.	Tray
Le79R70-1QC	32-pin QFN, Pol. Rev.	Tray
Le79R70-1FQC	32-pin QFN, Pol. Rev. (Green package)	Tray

1. Legerity reserves the right to fulfill all orders for this device with parts marked with the "Am" part number prefix, until such time as all inventory bearing this mark has been depleted. It should be noted that parts marked with either the "Am" or the "Le" part number prefix are equivalent devices in terms of form, fit, and function. The only difference between the two is in the part number prefix appearing on the topside mark.
2. Green package meets RoHS Directive 2002/95/EC of the European Council to minimize the environmental impact of electrical equipment.
3. Due to size constraints, QFN devices are marked by omitting the "Le" prefix and the performance grade dash character. For example, Le79R70-1QC is marked 79R701QC.
4. Not available for new customers.
5. For delivery using a tape and reel packing system, add a "T" suffix to the OPN (Ordering Part Number) when placing an order.

DESCRIPTION

The Le79R70 Ringing Subscriber Line Interface Circuit (RSLIC) device is a bipolar monolithic SLIC that offers on-chip ringing. Designers can achieve significant cost reductions at the system level for short-loop applications by integrating the ringing function on chip. Examples of such applications would be ISDN Terminal Adaptors and set top boxes. Using a CMOS-compatible input waveform and wave shaping R-C network, the Le79R70 Ringing SLIC device can provide trapezoidal wave ringing to meet various design requirements.

See the [Le79R70 Block Diagram, on page 3](#).

TABLE OF CONTENTS

Applications1
Features1
Related literature1
Ordering Information1
Description1
Product Description3
Connection Diagram4
Pin Descriptions5
Absolute Maximum Ratings6
Operating Ranges7
Environmental Ranges7
Electrical Characteristics8
Relay Driver Schematic10
DC Feed Characteristics13
Ring-Trip Components14
Test Circuits15
Application Circuit18
Physical Dimensions19
32-Pin PLCC19
32-Pin QFN20
Revision History21
Revision A to B21
Revision B to C21
Revision C to D21
Revision D to E21
Revision E to F21
Revision F to G121
Revision G1 to H121
Revision H1 to I121

PRODUCT DESCRIPTION

The Legerity family of subscriber line interface circuit (SLIC) products provide the telephone interface functions required throughout the worldwide market. Legerity SLIC devices address all major telephony markets including central office (CO), private branch exchange (PBX), digital loop carrier (DLC), fiber-in-the-loop (FITL), radio-in-the-loop (RITL), hybrid fiber coax (HFC), and video telephony applications.

The Legerity SLIC devices offer support of BORSHT (battery feed, over voltage protection, ringing, supervision, hybrid, and test) functions with features including current limiting, on-hook transmission, polarity reversal, tip-open, and loop-current detection. These features allow reduction of line card cost by minimizing component count, conserving board space, and supporting automated manufacturing.

The Legerity SLIC devices provide the two- to four-wire hybrid function, DC loop feed, and two-wire supervision. Two-wire termination is programmed by a scaled impedance network. Transhybrid balance can be achieved with an external balance circuit or simply programmed using a companion Legerity codec device, the Le79C02/03/031 DSLAC™ device, the Le79Q02/021/031 Programmable Quad SLAC (QSLAC™) device, or the Le79Q5457/4457 Non-programmable QSLAC device.

The Le79R70 Ringing SLIC device is a bipolar monolithic SLIC that offers on-chip ringing. Now designers can achieve significant cost reductions at the system level for short-loop applications by integrating the ringing function on chip. Examples of such applications would be ISDN Terminal Adaptors and set top boxes. Using a CMOS-compatible input waveform and wave shaping R-C network, the Le79R70 Ringing SLIC can provide trapezoidal wave ringing to meet various design requirements.

In order to further enhance the suitability of this device in short-loop, distributed switching applications, Legerity has maximized power savings by incorporating battery switching on chip. The Le79R70 Ringing SLIC device switches between two battery supplies such that in the Off-hook (active) state, a low battery is used to save power. In order to meet the Open Circuit voltage requirements of fax machines and maintenance termination units (MTU), the SLIC automatically switches to a higher voltage in the On-hook (standby) state.

Like all of the Legerity SLIC devices, the Le79R70 Ringing SLIC device supports on-hook transmission, ring-trip detection and programmable loop-detect threshold. The Le79R70 Ringing SLIC device is a programmable constant-current feed device with two on-chip relay drivers to operate external relays. This unique device is available in the proven Legerity 75 V bipolar process.

Figure 1. Le79R70 Block Diagram

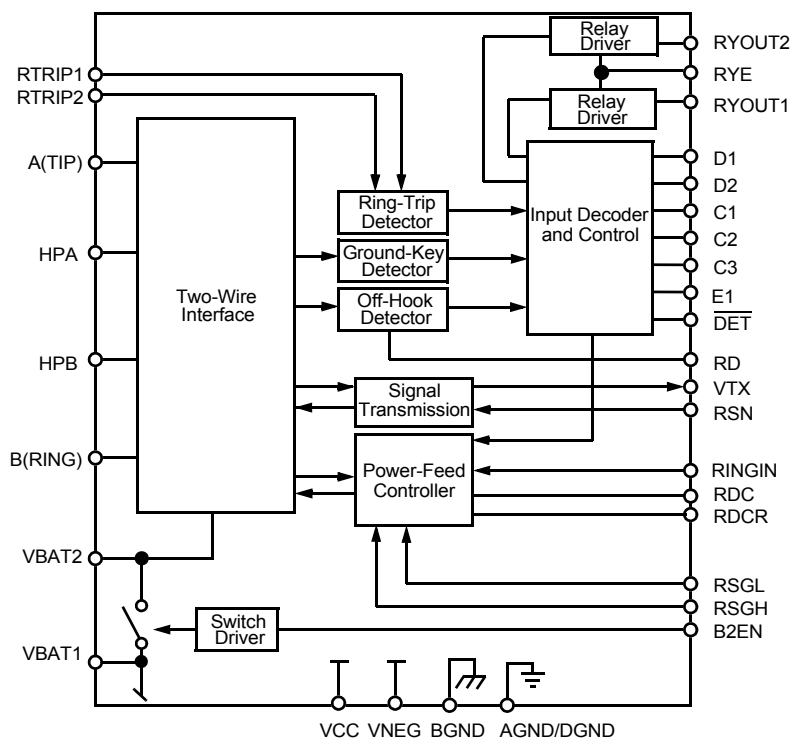

Pin Descriptions

Pin Names	Type	Description
AGND/DGND	Gnd	Analog and digital ground are connected internally to a single pin.
A(TIP)	Output	Output of A(TIP) power amplifier.
B2EN	Input	V _{BAT2} enable. Logic Low enables operation from V _{BAT2} . Logic High enables operation from V _{BAT1} . TTL compatible.
BGND	Gnd	Battery (power) ground
B(RING)	Output	Output of B(RING) power amplifier.
C3–C1	Input	Decoder. TTL compatible. C3 is MSB and C1 is LSB.
D1	Input	Relay1 control. TTL compatible. Logic Low activates the Relay1 relay driver.
D2	Input	(Option) Relay2 control. TTL compatible. Logic Low activates the Relay2 relay driver.
DET	Output	Detector. Logic Low indicates that the selected detector is tripped. Logic inputs C3–C1 and E1 select the detector. Open-collector with a built-in 15 k Ω pull-up resistor.
E1	Input	(Option) A logic High selects the off-hook detector. A logic Low selects the ground-key detector. TTL compatible.
HPA	Capacitor	High-pass filter capacitor. A(TIP) side of high-pass filter capacitor.
HPB	Capacitor	High-pass filter capacitor. B(RING) side of high-pass filter capacitor.
RD	Resistor	Detect resistor. Threshold modification and filter point for the off-hook detector.
RDC	Resistor	DC feed resistor. Connection point for the DC-feed current programming network, which also connects to the receiver summing node (RSN). V _{RDC} is negative for normal polarity and positive for reverse polarity.
RDCR	—	Connection point for feedback during ringing.
RINGIN	Input	Ring Signal Input. Pin for ring signal input. Square-wave shaped by external RC filter. Requires 50% duty cycle. CMOS-compatible input.
RSGH	Input	Saturation Guard High. Pin for resistor to adjust Open Circuit voltage when operating from V _{BAT1} .
RSGL	Input	Saturation Guard Low. Pin for resistor to adjust the anti-saturation cut-in voltage when operating from both V _{BAT1} and V _{BAT2} .
RSN	Input	The metallic current (AC and DC) between A(TIP) and B(RING) is equal to 1000 x the current into this pin. The networks that program receive gain, two-wire impedance, and feed resistance all connect to this node.
RTRIP1	Input	Ring-trip detector. Ring-trip detector threshold set and filter pin.
RTRIP2	Input	Ring-trip detector threshold offset (switch to V _{BAT1}). For power conservation in any non-ringing state, this switch is open.
RYE	Output	Common Emitter of RYOUT1/RYOUT2. Emitter output of RYOUT1 and RYOUT2. Normally connected to relay ground.
RYOUT1	Output	Relay/switch driver. Open-collector driver with emitter internally connected to RYE.
RYOUT2	Output	(Option) Relay/switch driver. Open-collector driver with emitter internally connected to RYE.
VBAT1	Battery	Battery supply and connection to substrate.
VBAT2	Battery	Power supply to output amplifiers. Connect to off-hook battery through a diode.
VCC	Power	Positive analog power supply.
VNEG	Power	Negative analog power supply. This pin is the return for the internal VEE regulator.
VTX	Output	Transmit Audio. This output is a 0.5066 gain version of the A(TIP) and B(RING) metallic AC voltage. VTX also sources the two-wire input impedance programming network.
Exposed Pad	Battery	This must be electrically tied to VBAT1.

ABSOLUTE MAXIMUM RATINGS

Stresses above those listed under *Absolute Maximum Ratings* can cause permanent device failure. Functionality at or above these limits is not implied. Exposure to absolute maximum ratings for extended periods may affect device reliability.

Storage temperature	-55 to +150°C
Ambient temperature under bias	0 to +70°C
V _{CC} with respect to AGND/DGND	0.4 to + 7 V
V _{NEG} with respect to AGND/DGND	0.4 V to V _{BAT2}
V _{BAT2}	V _{BAT2} to GND
V _{BAT1} with respect to AGND/DGND:	
Continuous	+0.4 to -80 V
10 ms	+0.4 to -85 V
BGND with respect to AGND/DGND	+3 to -3 V
A (TIP) or B (RING) to BGND:	
Continuous	V _{BAT1} - 5 V+ 1 V
10 ms (F = 0.1 Hz)	V _{BAT1} - 10 V+ 5 V
1 μs (F = 0.1 Hz)	V _{BAT1} - 15 V+ 8 V
250 ns (F = 0.1 Hz)	V _{BAT1} - 20 V+ 12 V
Current from A (TIP) or B (RING)	± 150 mA
RYOUT1, RYOUT2 current	75 mA
RYOUT1, RYOUT2 voltage	RYE to +7 V
RYOUT1, RYOUT2 transient	RYE to +10 V
RYE voltage	BGND to V _{BAT1}
C3-C1, D2-D1, E1, B2EN and RINGIN:	
Input voltage	-0.4 V to V _{CC} + 0.4 V
Maximum continuous power dissipation, T _A = 70° C ¹ :	
In 32-pin PLCC package	1.67 W
In 28-pin SOIC package	1.25 W
In 32-pin QFN package	3.00 W
Thermal Data:	θ _{JA}
In 32-pin PLCC package	45° C/W
In 28-pin SOIC package	60° C/W
In 32-pin QFN package ²	25° C/W
ESD Immunity (Human Body Model)	JESD22 Class 1C compliant

Note:

1. Thermal limiting circuitry on the chip will shut down the circuit at a junction temperature of about 165°C. Continuous operation above 145°C junction temperature may degrade device reliability.
2. The thermal performance of a thermally enhanced package is assured through optimized printed circuit board layout. Specified performance requires that the exposed thermal pad be soldered to an equally sized exposed copper surface, which, in turn, conducts heat through multiple vias to a large internal copper plane.

Package Assembly

The standard (non-green) package devices are assembled with industry-standard mold compounds, and the leads possess a tin/lead (Sn/Pb) plating. These packages are compatible with conventional SnPb eutectic solder board assembly processes. The peak soldering temperature should not exceed 225°C during printed circuit board assembly.

The green package devices are assembled with enhanced environmental compatible lead (Pb), halogen, and antimony-free materials. The leads possess a matte-tin plating which is compatible with conventional board assembly processes or newer lead-free board assembly processes. The peak soldering temperature should not exceed 245°C during printed circuit board assembly.

Refer to IPC/JEDEC J-Std-020B Table 5-2 for the recommended solder reflow temperature profile.

OPERATING RANGES

Environmental Ranges

Legerity guarantees the performance of this device over the commercial (0° C to 70° C) temperature range by conducting electrical characterization and by conducting a production test with single insertion coupled to periodic sampling. These characterization and test procedures comply with section 4.6.2 of Bellcore GR-357-CORE Component Reliability Assurance Requirements for Telecommunications Equipment.

Environmental Ranges

Ambient Temperature	0 to 70° C
---------------------	------------

Electrical Ranges

V _{CC}	4.75 V to 5.25 V
V _{NEG}	-4.75 V to V _{BAT2}
V _{BAT1}	-40 to -67 V
V _{BAT2}	-19 V to V _{BAT1}
AGND/DGND	0 V
BGND with respect to AGND/DGND	-100 mV to +100 mV
Load resistance on VTX to GND	20 kΩ min

Note:

The Operating Ranges define those limits between which the functionality of the device is guaranteed.

ELECTRICAL CHARACTERISTICS

Description	Test Conditions (See Note 1)	Min	Typ	Max	Unit	Note	
Transmission Performance							
2-wire return loss	200 Hz to 3.4 kHz (Test Circuit D)	26			dB	1, 4, 6	
Z_{VTX} , analog output impedance			3	20	Ω	4	
V_{VTX} , analog output offset voltage		-50		+50	mV		
Z_{RSN} , analog input impedance			1	20	Ω	4	
Overload level, 2-wire and 4-wire, off hook	Active state	2.5			Vpk	2a	
Overload level, 2-wire	On hook, $R_{LAC} = 600 \Omega$	0.88			Vrms	2b	
THD (Total Harmonic Distortion)	+3 dBm, BAT2 = -24 V		-64	-50	dB	5	
THD, on hook, OHT state	0 dBm, $R_{LAC} = 600 \Omega$, BAT1 = -67 V			-40			
Longitudinal Performance (See Test Circuit C)							
Longitudinal to metallic L-T, L-4 balance	200 Hz to 3.4 kHz	40			dB		
Longitudinal signal generation 4-L	200 Hz to 800 Hz, Normal polarity	40					
Longitudinal current per pin (A or B)	Active or OHT state	12	28		mArms	4	
Longitudinal impedance at A or B	0 to 100 Hz, $T_A = +25^\circ\text{C}$		25		Ω/pin		
Idle Channel Noise							
C-message weighted noise			+7	+14	dBrnC		
Psophometric weighted noise			-83	-76	dBmp	4	
Insertion Loss and Four- to Four-Wire Balance Return Signal (See Test Circuits A and B)							
Gain accuracy	4- to 2-wire	0 dBm, 1 kHz	-0.20	0	+0.20	dB	3
Gain accuracy	2- to 4-wire and 4- to 4-wire	0 dBm, 1 kHz	-6.22	-6.02	-5.82		
Gain accuracy	4- to 2-wire	OHT state, on hook	-0.35	0	+0.35		
Gain accuracy	2- to 4-wire and 4- to 4-wire	OHT state, on hook	-6.37	-6.02	-5.77		
Gain accuracy over frequency		300 to 3400 Hz relative to 1 kHz	-0.10		+0.10		
Gain tracking		+3 dBm to -55 dBm relative to 0 dBm	-0.10		+0.10		3, 4
Gain tracking OHT state, on hook		0 dBm to -37 dBm +3 dBm to 0 dBm	-0.10 -0.35		+0.10 +0.35		3, 4 3
Group delay		0 dBm, 1 kHz		3		μs	1, 4, 6

ELECTRICAL CHARACTERISTICS (CONTINUED)

Description	Test Conditions (See Note 1)	Min	Typ	Max	Unit	Note
Line Characteristics						
I_L , Loop-current accuracy	I_L in constant-current region, B2EN = 0	$0.9I_L$	I_L	$1.1I_L$	mA	
I_L , Long loops, Active state	$R_{LDC} = 600 \Omega$, RSGL = open $R_{LDC} = 750 \Omega$, RSGL = short	20 20	21.7			
I_L , Accuracy, Standby state	$I_L = \frac{ V_{BAT1} - 10 \text{ V}}{R_L + 400}$	$0.8I_L$	I_L	$1.2I_L$		
	I_L = constant-current region $T_A = 25^\circ\text{C}$	18	27	39		
$I_{L\text{LIM}}$	Active, A and B to ground OHT, A and B to ground		55 55	110		4
I_L , Loop current, Open Circuit state	$R_L = 0$			100	μA	
I_A , Pin A leakage, Tip Open state	$R_L = 0$			100		
I_B , Pin B current, Tip Open state	B to ground		34		mA	
V_A , Standby, ground-start signaling	A to $-48 \text{ V} = 7 \text{ k}\Omega$, B to ground = 100Ω	-7.5	-5			V
V_{AB} , Open Circuit voltage		42				
Power Supply Rejection Ratio ($V_{\text{RIPPLE}} = 100 \text{ mVrms}$), Active Normal State						
V_{CC}	50 Hz to 3400 Hz	33	50		dB	5
V_{NEG}	50 Hz to 3400 Hz	30	40			
V_{BAT1}	50 Hz to 3400 Hz	30	50			
V_{BAT2}	50 Hz to 3400 Hz	30	50			
Power Dissipation						
On hook, Open Circuit state	V_{BAT1}		48	100	mW	
On hook, Standby state	V_{BAT2}		55	80		9
On hook, OHT state	V_{BAT1}		200	300		
On hook, Active state	V_{BAT1}		220	350		
Off hook, Standby state	V_{BAT1} or V_{BAT2}	$R_L = 300 \Omega$	2000	2800		9
Off hook, OHT state	V_{BAT1}	$R_L = 300 \Omega$	2000	2200		
Off hook, Active state	V_{BAT2}	$R_L = 300 \Omega$	550	750		
Supply Currents						
I_{CC} , On-hook V_{CC} supply current	Open Circuit state		3.0	4.5	mA	
	Standby state		3.2	5.5		
	OHT state		6.2	8.0		
	Active state–normal		6.5	9.0		
I_{NEG} , On-hook V_{NEG} supply current	Open Circuit state		0.1	0.2	mA	
	Standby state		0.1	0.2		
	OHT state		0.7	1.1		
	Active state–normal		0.7	1.1		
I_{BAT} , On-hook V_{BAT} supply current	Open Circuit state		0.45	1.0	mA	
	Standby state		0.6	1.5		
	OHT state		2.0	4.0		
	Active state–normal		2.7	5.0		

ELECTRICAL CHARACTERISTICS (continued)

Description	Test Conditions (See Note 1)	Min	Typ	Max	Unit	Note
Logic Inputs (C3–C1, D2–D1, E1, and B2EN)						
V _{IH} , Input High voltage		2.0			V	
V _{IL} , Input Low voltage				0.8	V	
I _{IH} , Input High current		–75		40	μA	
I _{IL} , Input Low current		–400			μA	
Logic Output DET						
V _{OL} , Output Low voltage	I _{OUT} = 0.8 mA, 15 kΩ to V _{CC}			0.40	V	
V _{OH} , Output High voltage	I _{OUT} = –0.1 mA, 15 kΩ to V _{CC}	2.4			V	
Ring-Trip Detector Input						
Ring detect accuracy	$I_{RTD} = \left(\frac{ BAT1 - 1}{RRT1} + 24 \mu A \right) \cdot 335$	–10		+10	%	
Ring Signal						
V _{AB} , Ringing	Bat1 = –67 V, ringload = 1570 Ω	57	61		V _{pk}	
V _{AB} Ringing offset	V _{RINGIN} = 2.5 V		0		V	
ΔV _{AB} /ΔV _{RINGIN} (RINGIN gain)			180		—	
Ground-Key Detector Thresholds						
Ground-key resistive threshold	B to ground	2	5	10	kΩ	
Ground-key current threshold	B to ground		11		mA	
Loop Detector						
R _{LTH} , Loop-resistance detect threshold	Active, V _{BAT1} Active, V _{BAT2} Standby	–20 –20 –12		20 20 12	%	8
Relay Driver Output (RELAY1 and 2)						
V _{OL} , On voltage (each output)	I _{OL} = 30 mA		+0.25	+0.4	V	
V _{OL} , On voltage (each output)	I _{OL} = 40 mA		+0.30	+0.8	V	4
I _{OH} , Off leakage (each output)	V _{OH} = +5 V			100	μA	
Zener breakover (each output)	I _Z = 100 μA	6.6	7.9		V	
Zener on voltage (each output)	I _Z = 30 mA		11		V	

RELAY DRIVER SCHEMATIC

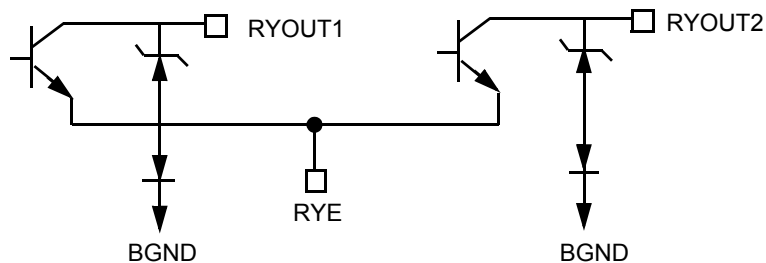

Notes:

- Unless otherwise noted, test conditions are $BAT1 = -67\text{ V}$, $BAT2 = -24\text{ V}$, $V_{CC} = +5\text{ V}$, $V_{NEG} = -5\text{ V}$, $R_L = 600\ \Omega$, $R_{DC1} = 80\text{ k}\Omega$, $R_{DC2} = 20\text{ k}\Omega$, $R_D = 75\text{ k}\Omega$, no fuse resistors, $C_{HP} = 0.018\ \mu\text{F}$, $C_{DC} = 1.2\ \mu\text{F}$, $D_1 = D_2 = 1\text{N}400\text{x}$, two-wire AC input impedance (ZSL) is a $600\ \Omega$ resistance synthesized by the programming network shown below. $R_{SGL} = \text{open}$, $R_{SGH} = \text{open}$, $R_{DCR} = 2\text{ k}\Omega$, $R_{RT1} = 430\text{ k}\Omega$, $R_{RT2} = 12\text{ k}\Omega$, $C_{RT} = 1.5\ \mu\text{F}$, $R_{SLEW} = 150\text{ k}\Omega$, $C_{SLEW} = 0.33\ \mu\text{F}$.

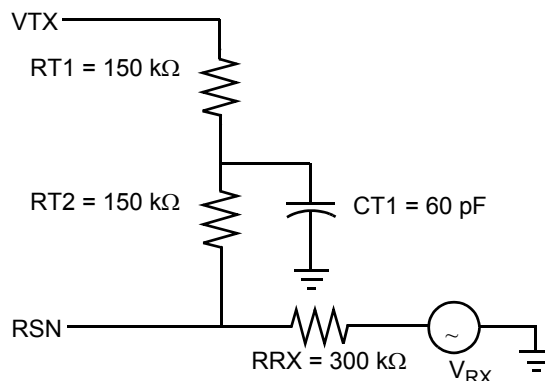

- Overload level is defined when $THD = 1\%$.
 - Overload level is defined when $THD = 1.5\%$.
- Balance return signal is the signal generated at V_{TX} by V_{RX} . This specification assumes that the two-wire AC load impedance matches the programmed impedance.
- Not tested in production. This parameter is guaranteed by characterization or correlation to other tests.
- This parameter is tested at 1 kHz in production. Performance at other frequencies is guaranteed by characterization.
- Group delay can be greatly reduced by using a Z_T network such as that shown in Note 1 above. The network reduces the group delay to less than $2\ \mu\text{s}$ and increases 2WRL . The effect of group delay on line card performance may also be compensated for by synthesizing complex impedance with the QSLAC or DSLAC device.
- Open Circuit V_{AB} can be modified using RSGH.
- R_D must be greater than $56\text{ k}\Omega$. Refer to [Table 2](#) for typical value of R_{LTH} .
- Lower power is achieved by switching into low-battery state in standby. Standby loop current is returned to V_{BAT1} regardless of the battery selected.

Table 1. SLIC Decoding

State	C3 C2 C1	2-Wire Status	(DET) Output		Battery Selection
			E1 = 1	E1 = 0	
0	0 0 0	Open Circuit	Ring trip	Ring trip	B2EN
1	0 0 1	Ringing	Ring trip	Ring trip	
2	0 1 0	Active	Loop detector	Ground key	
3	0 1 1	On-hook TX (OHT)	Loop detector	Ground key	
4	1 0 0	Tip Open	Loop detector	Ground key	B2EN = 1**
5	1 0 1	Standby	Loop detector	Ground key	V_{BAT1}
6*	1 1 0	Active Polarity Reversal	Loop detector	Ground key	B2EN
7*	1 1 1	OHT Polarity Reversal	Loop detector	Ground key	

Notes:

- * Only -1 performance grade devices support polarity reversal.
- ** For correct ground-start operation using Tip Open, V_{BAT1} on-hook battery must be used.

Table 2. User-Programmable Components

$Z_T = 500(Z_{2WIN} - 2R_F)$	<p>Z_T is connected between the VTX and RSN pins. The fuse resistors are R_F, and Z_{2WIN} is the desired 2-wire AC input impedance. When computing Z_T, the internal current amplifier pole and any external stray capacitance between VTX and RSN must be taken into account.</p>
$Z_{RX} = \frac{Z_L}{G_{42L}} \cdot \frac{1000 \cdot Z_T}{Z_T + 500(Z_L + 2R_F)}$	<p>Z_{RX} is connected from V_{RX} to R_{SN}. Z_T is defined above, and G_{42L} is the desired receive gain.</p>
$R_{DC1} + R_{DC2} = \frac{2500}{I_{LOOP}}$ $R_{DCR1} + R_{DCR2} = \frac{3000}{I_{ringlim}}$ $C_{DC} = 19 \text{ ms} \cdot \frac{R_{DC1} + R_{DC2}}{R_{DC1}R_{DC2}}$ $C_{DCR} = \frac{R_{DCR1} + R_{DCR2}}{R_{DCR1}R_{DCR2}} \cdot 150 \mu\text{s}$	<p>R_{DC1}, R_{DC2}, and C_{DC} form the network connected to the RDC pin. I_{LOOP} is the desired loop current in the constant-current region.</p> <p>R_{DCR1}, R_{DCR2}, and C_{DCR} form the network connected to the RDCR pin. See Applications Circuit for these components.</p> <p>C_{DCR} sets the ringing time constant, which can be between 15 μs and 150 μs.</p>
$R_D = R_{LTH} \cdot 12.67 \text{ for high battery state}$	<p>R_D is the resistor connected from the RD pin to GND and R_{LTH} is the loop-resistance threshold between on-hook and off-hook detection. R_D should be greater than 56 kΩ to guarantee detection will occur in the Standby state. Choose the value of R_D for high battery state; then use the equation for R_{LTH} to find where the threshold is for low battery.</p>
<p>Loop-Threshold Detect Equations</p>	
$R_{LTH} = \frac{R_D}{12.67} \text{ for high battery}$	<p>This is the same equation as for R_D in the preceding equation, except solved for R_{LTH}.</p>
$R_{LTH} = \frac{R_D}{11.37} \text{ for low battery}$	<p>For low battery, the detect threshold is slightly higher, which will avoid oscillating between states.</p>
$R_{LTH} = \frac{ V_{BAT1} - 10}{915} \cdot R_D - 400 - 2R_F$	<p>$R_{LTH} \text{ standby} < R_{LTH} \text{ active} < V_{BAT1} < R_{LTH} \text{ active} < V_{BAT2}$, which will guarantee no unstable states under all operating conditions. This equation will show at what resistance the standby threshold will be; it is actually a current threshold rather than a resistance threshold, which is shown by the Vbat dependency.</p>

DC FEED CHARACTERISTICS

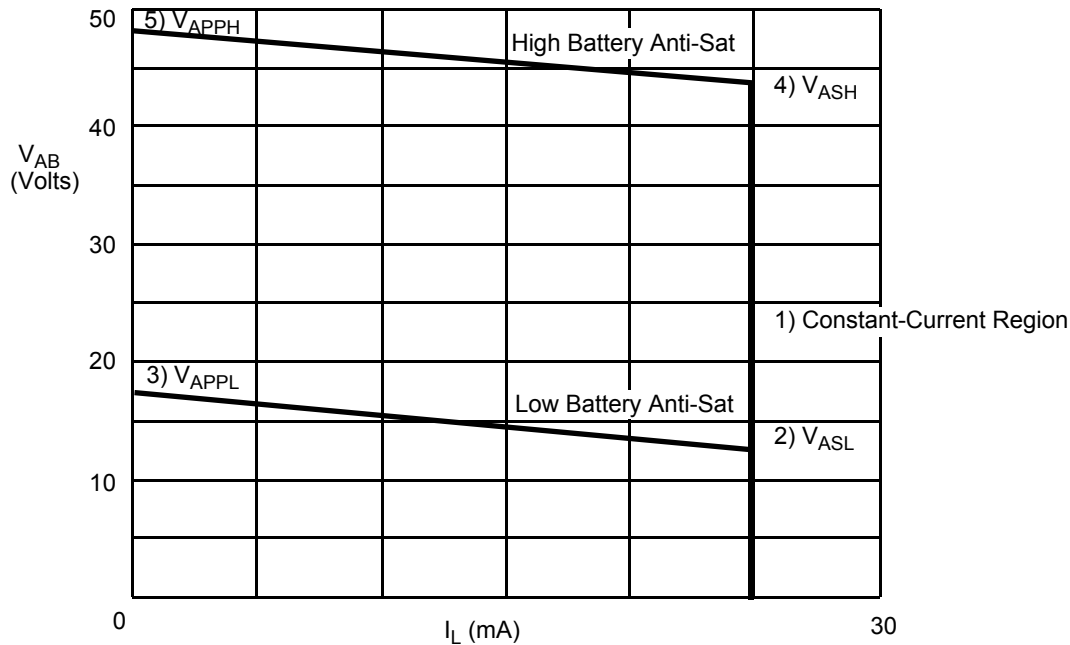

Figure 1. Typical V_{AB} vs. I_L DC Feed Characteristics

$$R_{DC} = R_{DC1} + R_{DC2} = 20 \text{ k}\Omega + 80 \text{ k}\Omega = 100 \text{ k}\Omega$$

$$(V_{BAT1} = -67 \text{ V}, V_{BAT2} = -24 \text{ V})$$

Notes:

1. Constant-current region: $V_{AB} = I_L R_L = \frac{2500}{R_{DC}} R_L$; where $R_L = R_L + 2R_F$

2. Low battery $V_{ASL} = \frac{1000 \cdot (104 \cdot 10^3 + R_{SGL})}{6720 \cdot 10^3 + (80 \cdot R_{SGL})}$; where R_{SGL} = resistor to GND, B2EN = logic Low.

Anti-sat region: $V_{ASL} = \frac{1000 \cdot (R_{SGL} - 56 \cdot 10^3)}{6720 \cdot 10^3 + (80 \cdot R_{SGL})}$; where R_{SGL} = resistor to V_{CC} , B2EN = logic Low.

R_{SGL} to V_{CC} must be greater than 100 k Ω .

3. $V_{APPL} = 4.17 + V_{ASL}$

$$I_{LOOP} = \frac{V_{APPL}}{\frac{(R_{DC1} + R_{DC2})}{600} + 2R_F + R_{LOOP}}$$

4. High battery $V_{ASH} = V_{ASHH} + V_{ASL}$

Anti-sat region: $V_{ASHH} = \frac{1000 \cdot (70 \cdot 10^3 + R_{SGH})}{1934 \cdot 10^3 + (31.75 \cdot R_{SGH})}$; where R_{SGH} = resistor to GND, B2EN = logic High.

$$V_{ASHH} = \frac{1000 \cdot (R_{SGH} + 2.75 \cdot 10^3)}{1934 \cdot 10^3 + (31.75 \cdot R_{SGH})}$$
; where R_{SGH} = resistor to V_{CC} , B2EN = logic High.

R_{SGH} to V_{CC} must be greater than 100 k Ω .

5. $V_{APPH} = 4.17 + V_{ASH}$

$$I_{LOOHP} = \frac{V_{APPH}}{\frac{(R_{DC1} + R_{DC2})}{600} + 2R_F + R_{LOOHP}}$$

RING-TRIP COMPONENTS

$$R_{RT2} = 12 \text{ k}\Omega$$

$$C_{RT} = 1.5 \text{ }\mu\text{F}$$

$$R_{RT1} = 320 \cdot CF \cdot \frac{V_{BAT1}}{V_{BAT1} - 5 - (24 \text{ }\mu\text{A} \cdot 320 \cdot CF \cdot (R_{LRT} + 150 + 2R_F))} \cdot (R_{LRT} + 150 + 2R_F)$$

where R_{LRT} = Loop-detection threshold resistance for ring trip and CF = Crest factor of ringing signal (≈ 1.25)

R_{SLEW} , C_{SLEW}

Ring waveform rise time $\approx 0.214 \cdot (R_{SLEW} \cdot C_{SLEW}) \approx tr$.

For a 1.25 crest factor @ 20 Hz, $tr \approx 10 \text{ mS}$.

$\therefore (R_{SLEW} = 150 \text{ k}\Omega, C_{SLEW} = 0.33 \text{ }\mu\text{F})$

C_{SLEW} should be changed if a different crest factor is desired.

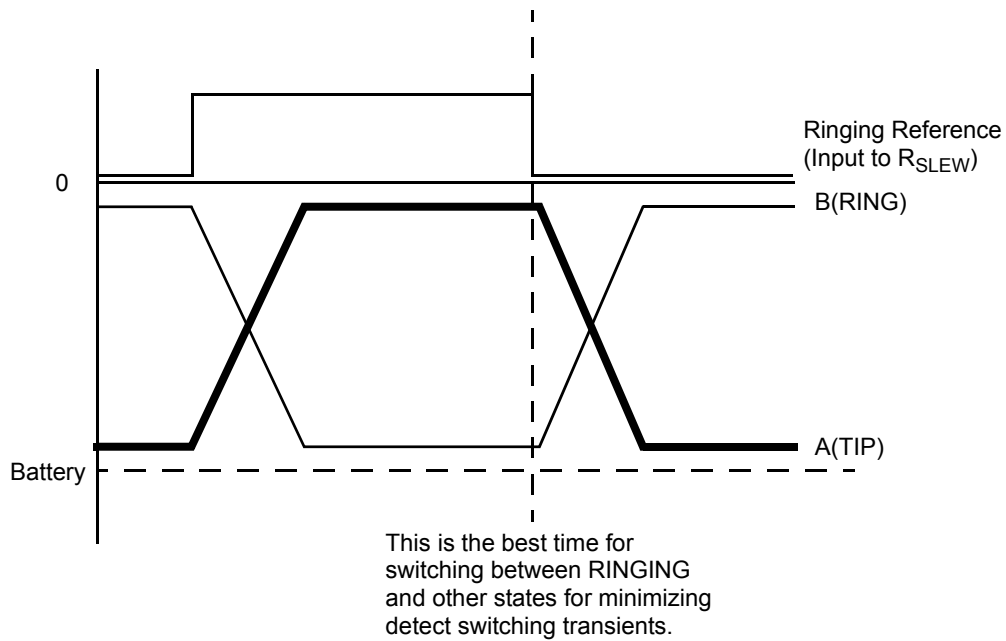
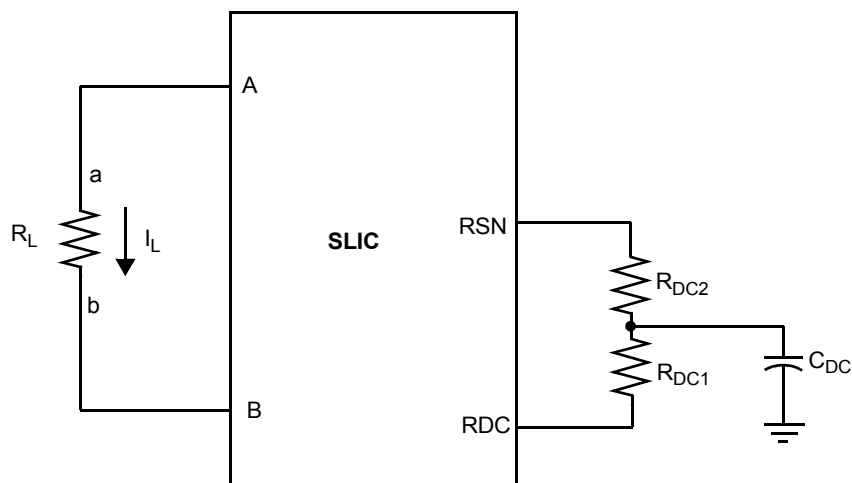

Figure 2. Ringing Waveforms



Feed current programmed by R_{DC1} and R_{DC2}

Figure 3. Feed Programming

TEST CIRCUITS

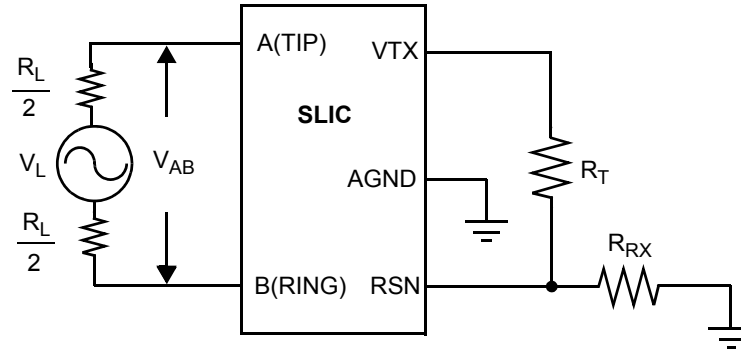

$$I_{L2-4} = 20 \log (V_{TX} / V_{AB})$$

A. Two- to Four-Wire Insertion Loss

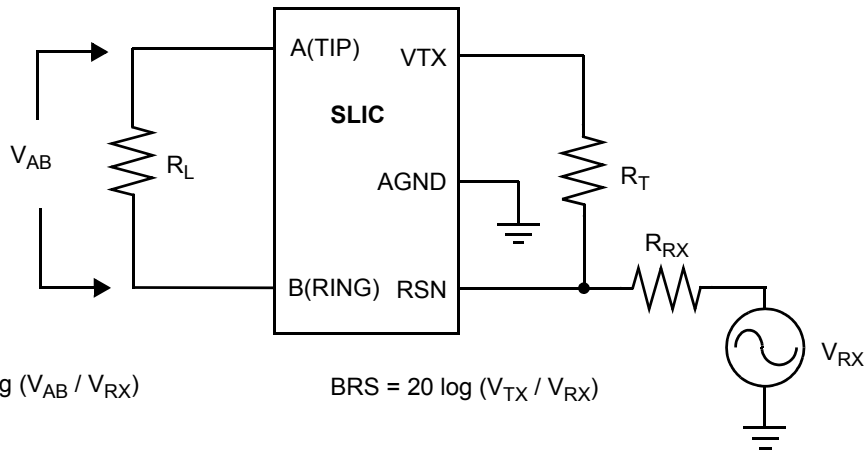

$$I_{L4-2} = 20 \log (V_{AB} / V_{RX})$$

$$BRS = 20 \log (V_{TX} / V_{RX})$$

B. Four- to Two-Wire Insertion Loss and Four- to Four-Wire Balance Return Signal

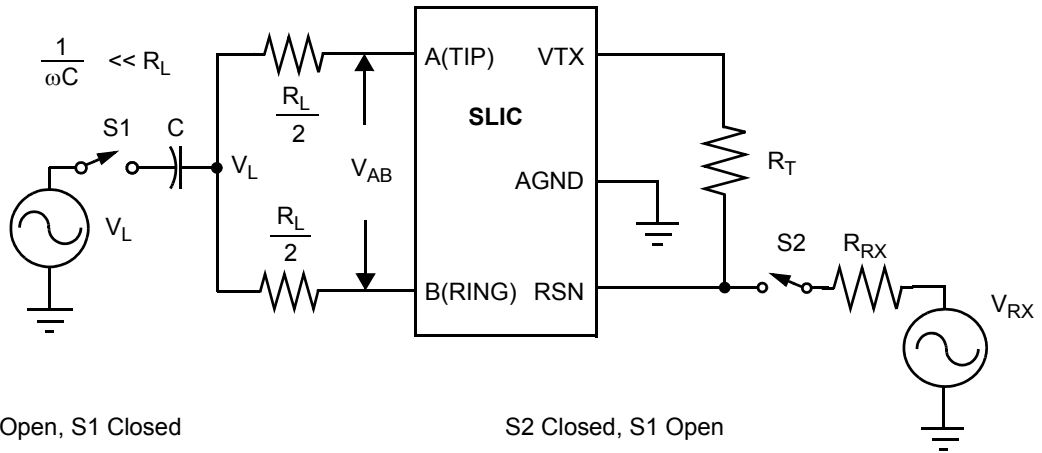

S2 Open, S1 Closed

$$L-T \text{ Long. Bal.} = 20 \log (V_{AB} / V_L)$$

$$L-4 \text{ Long. Bal.} = 20 \log (V_{TX} / V_L)$$

S2 Closed, S1 Open

$$4-L \text{ Long. Sig. Gen.} = 20 \log (V_L / V_{RX})$$

C. Longitudinal Balance

TEST CIRCUITS (continued)

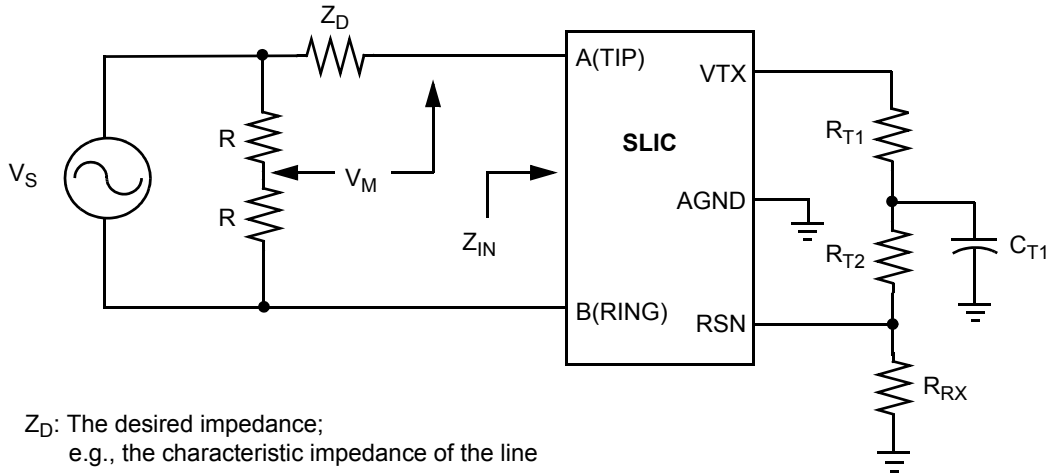

Z_D : The desired impedance;
e.g., the characteristic impedance of the line

$$\text{Return loss} = -20 \log (2 V_M / V_S)$$

D. Two-Wire Return Loss Test Circuit

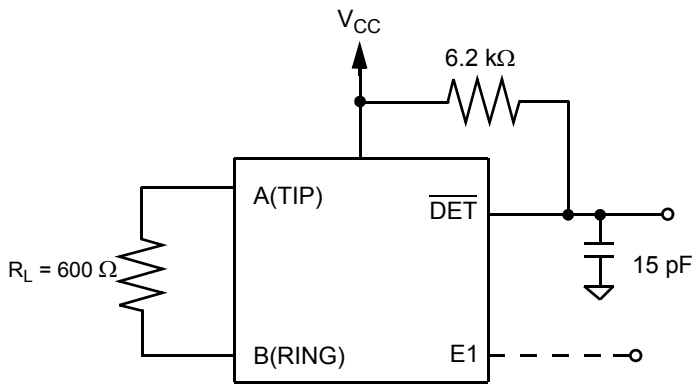

E. Loop-Detector Switching

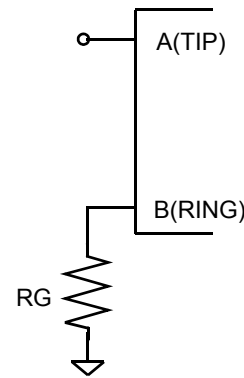

F. Ground-Key Switching

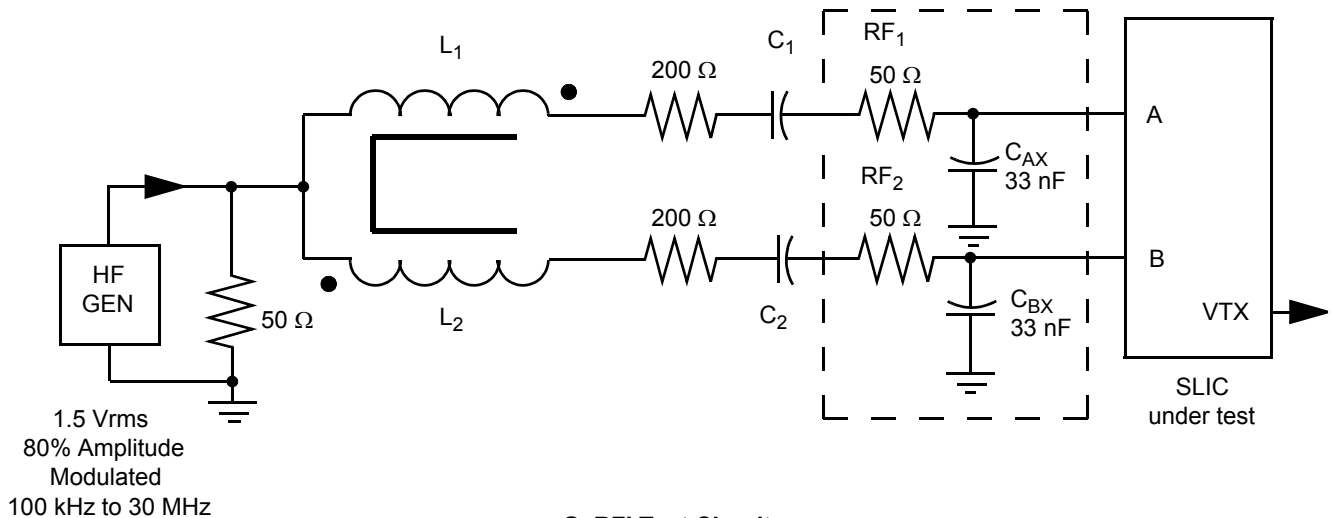

G. RFI Test Circuit

TEST CIRCUITS (continued)

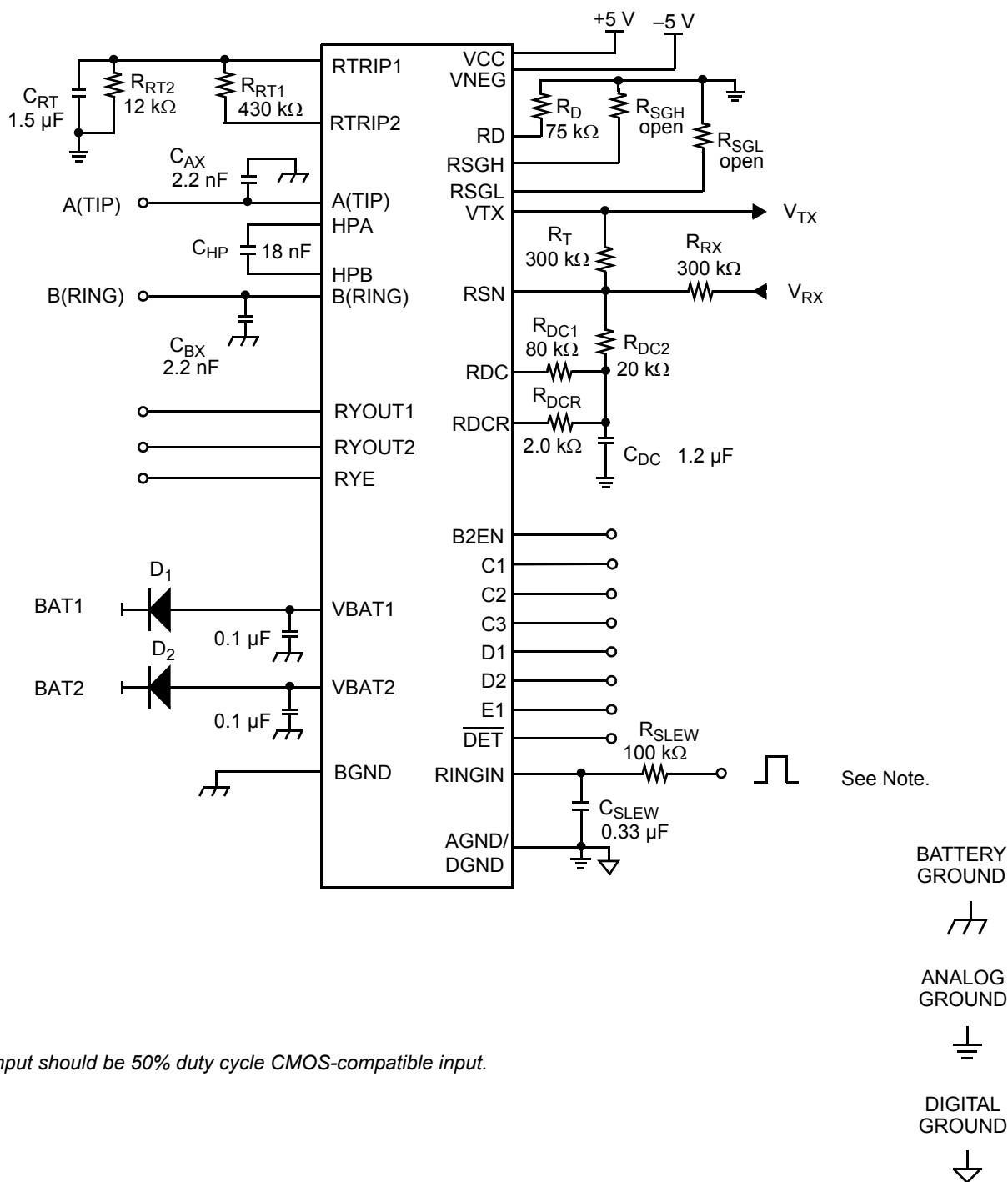

H. Le79R70 Test Circuit

APPLICATION CIRCUIT

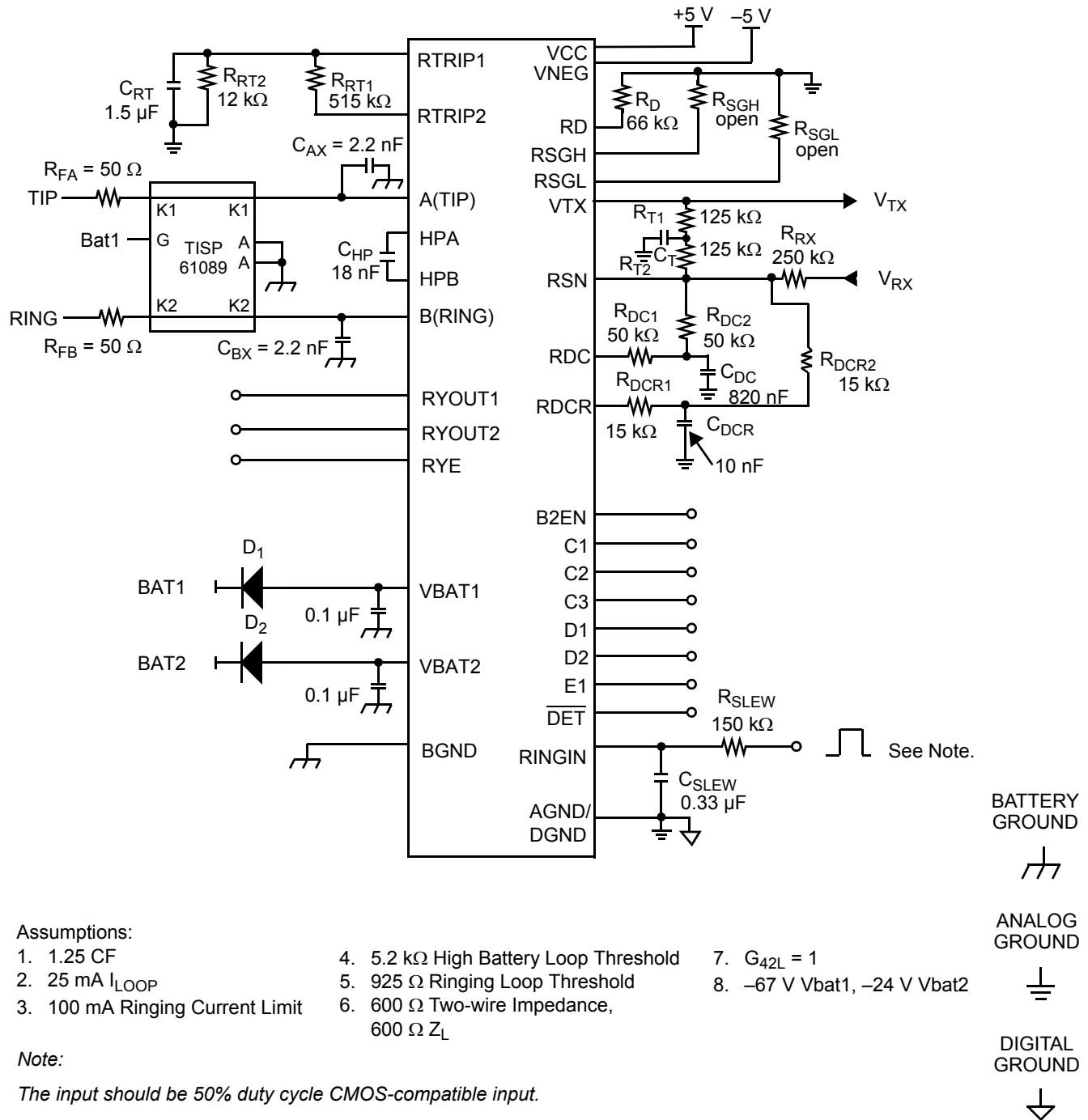

I. Application Circuit

PHYSICAL DIMENSIONS

32-Pin PLCC

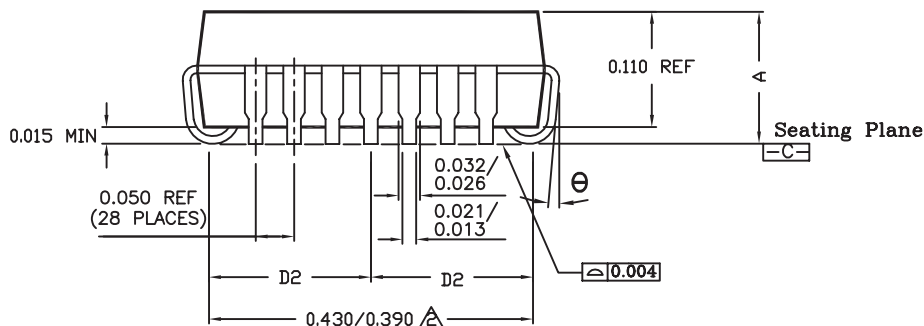
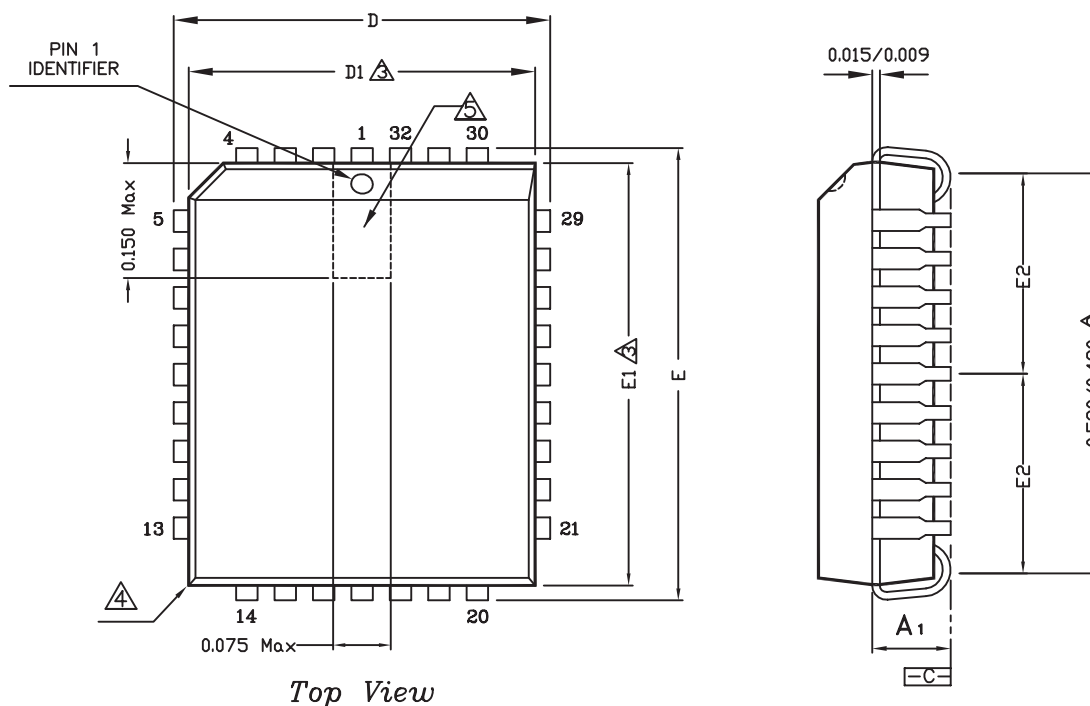

NOTE :

1. DIMENSIONING AND TOLERANCING CONFORM TO ASME Y14.5M-1994.
- △ TO BE MEASURED AT SEATING PLANE \square -C CONTACT POINT.
- △ DIMENSIONS D1 AND E1 DO NOT INCLUDE MOLD PROTRUSION. ALLOWABLE MOLD PROTURSION IS 0.010 IN PER SIDE. DIMENSIONS D, AND E, INCLUDE MOLD MISMATCH AND DETERMINED AT THE PARTING LINE; THAT IS D1 AND E1 ARE MEASURED AT THE EXTREME MATERIAL CONDITION AT THE UPPER OR LOWER PARTING LINE.
- △ EXACT SHAPE OF THIS FEATURE IS OPTIONAL.
- △ DETAILS OF PIN 1 IDENTIFIER ARE OPTIONAL BUT MUST BE LOCATED WITHIN THE ZONE INDICATED.
6. SUM OF DAM BAR PROTRUSIONS TO BE 0.007 MAX PER LEAD.
7. CONTROLLING DIMENSION : INCH.
8. REFERENCE DOCUMENT : JEDEC MS-016

Symbol	Dimension in inch		
	Min	Norm	Max
A	0.125	—	0.140
A1	0.075	0.090	0.095
D	0.485	0.490	0.495
D1	0.447	0.450	0.453
D2	0.205 REF		
E	0.585	0.590	0.595
E1	0.547	0.550	0.553
E2	0.255 REF		
θ	0°	—	10°

Note:

Packages may have mold tooling markings on the surface. These markings have no impact on the form, fit or function of the device. Markings will vary with the mold tool used in manufacturing.

32-Pin QFN

32 Lead QFN with Chamfer

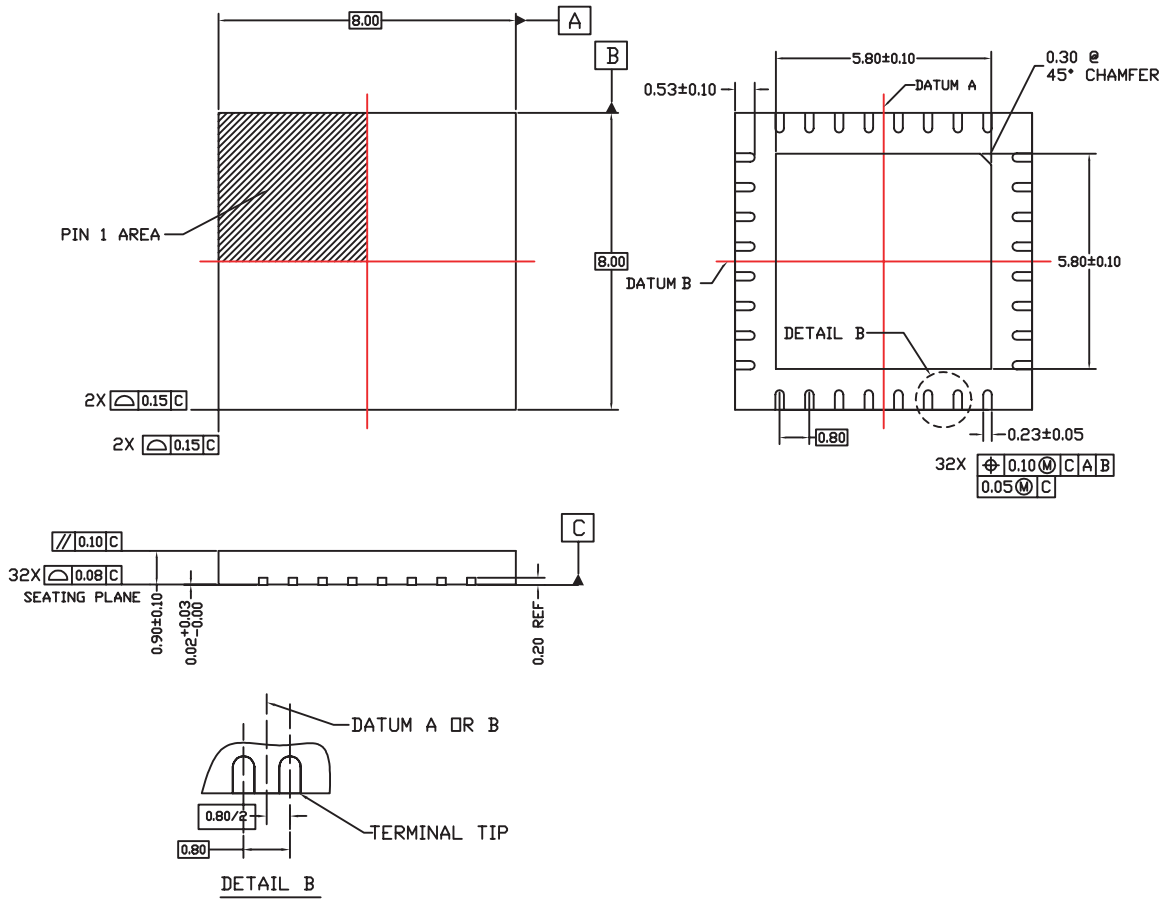

Symbol	32 LEAD QFN		
	Min	Nom	Max
A	0.80	0.90	1.00
A2	0.57 REF		
b	0.18	0.23	0.28
D	8.00 BSC		
D2	5.70	5.80	5.90
E	8.00 BSC		
E2	5.70	5.80	5.90
e	0.80 BSC		
L	0.43	0.53	0.63
N	32		
A1	0.00	0.02	0.05
A3	0.20 REF		
aaa	0.20		
bbb	0.10		
ccc	0.10		

NOTES:

1. Dimensioning and tolerancing conform to ASME Y14.5M-1994.
2. All dimensions are in millimeters. ϕ is in degrees.
3. N is the total number of terminals.
4. The Terminal #1 identifier and terminal numbering convention shall conform to JEP 95-1 and SSP-012. Details of the Terminal #1 identifier are optional, but must be located within the zone indicated. The Terminal #1 identifier may be either a mold or marked feature.
5. Coplanarity applies to the exposed pad as well as the terminals.
6. Reference Document: JEDEC MO-220.
7. Lead width deviates from the JEDEC MO-220 standard.

Note:

Packages may have mold tooling markings on the surface. These markings have no impact on the form, fit or function of the device. Markings will vary with the mold tool used in manufacturing.

REVISION HISTORY

Revision A to B

- Minor changes were made to the data sheet style and format to conform to Legerity standards.

Revision B to C

- The 28-pin SOIC information and package was added to the Ordering Information and the Connection Diagrams sections.
- The physical dimensions (PL032 and SOW28) were added to the Physical Dimensions section.
- Updated the Pin Description table to correct inconsistencies.

Revision C to D

- Changed Ring-Trip Components equation from:

$$R_{RT1} = 300 \cdot CF \cdot \frac{V_{BAT1}}{V_{bat} - 3.5 - (15 \mu A \cdot 300 \cdot CF \cdot (R_{LRT} + 150 + 2R_F))} \cdot (R_{LRT} + 150 + 2R_F)$$

To:

$$R_{RT1} = 320 \cdot CF \cdot \frac{V_{BAT1}}{V_{bat} - 5 - (24 \mu A \cdot 320 \cdot CF \cdot (R_{LRT} + 150 + 2R_F))} \cdot (R_{LRT} + 150 + 2R_F)$$

Revision D to E

- In “Ordering Information” section, added description for wafer foundry facility optional character.

Revision E to F

- Updated device name from “Am79R70” to “Le79R70” throughout document.
- Added QFN package to “Connection Diagram,” “Absolute Maximum Ratings,” and “Physical Dimensions.”
- Removed reference to PLCC package type in “General Description.”
- Ordering Information: Temperature statement updated to standard.
- Absolute Maximum Ratings: Notes updated to standard.
- Operating Ranges: Temperature statement updated to standard.

Revision F to G1

- Added green package OPNs to [Ordering Information, on page 1](#)
- Added [Package Assembly, on page 6](#)

Revision G1 to H1

- Added “Packing” column and Note 5 to [Ordering Information, on page 1](#)
- Updated 32QFN drawing in [Physical Dimensions, on page 19](#)

Revision H1 to I1

- Added green package OPNs and removed OPN for SOIC package in [Ordering Information, on page 1](#)
- Removed SOIC drawing in [Physical Dimensions, on page 19](#)
- Added note to [Physical Dimensions, on page 19](#)

The contents of this document are provided in connection with Legerity, Inc. products. Legerity makes no representations or warranties with respect to the accuracy or completeness of the contents of this publication and reserves the right to make changes to specifications and product descriptions at any time without notice. No license, whether express, implied, arising by estoppel or otherwise, to any intellectual property rights is granted by this publication. Except as set forth in Legerity's Standard Terms and Conditions of Sale, Legerity assumes no liability whatsoever, and disclaims any express or implied warranty, relating to its products including, but not limited to, the implied warranty of merchantability, fitness for a particular purpose, or infringement of any intellectual property right. Legerity's products are not designed, intended, authorized or warranted for use as components in systems intended for surgical implant into the body, or in other applications intended to support or sustain life, or in any other application in which the failure of Legerity's product could create a situation where personal injury, death, or severe property or environmental damage may occur. Legerity reserves the right to discontinue or make changes to its products at any time without notice.

© 2005 Legerity, Inc.
All rights reserved.

Trademarks

Legerity, the Legerity logo and combinations thereof, and VoiceEdge are trademarks of Legerity, Inc.
Other product names used in this publication are for identification purposes only and may be trademarks of their respective companies.



4509 Freidrich Lane
Austin, Texas 78744-1812

Telephone: (512) 228-5400
Fax: (512) 228-5508
North America Toll Free: (800) 432-4009

To find the Legerity Sales Office nearest you, visit our website at:

<http://www.legerity.com/sales>

or email:

sales@legerity.com

To download or order data sheets, application notes, or evaluation tools, go to:

www.legerity.com/support

For all other technical inquiries, please contact Legerity Tech Support at:

techsupport@legerity.com

or call +1 512.228.5400.