

Triple 3-Input Positive NAND Gate

The LS10 is a bipolar, NPN, sealed-junction, silicon integrated circuit. It is manufactured in low-power Schottky technology and is available in a wire-bonded, 14-pin plastic DIP or surface mount package.

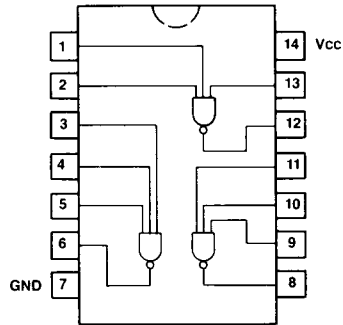

Electrical Characteristics

V_{CC} = 5.0 ±0.5 V, T_A = -55 to +125°C (WA-LS)
 V_{CC} = 5.0 ±0.25 V, T_A = 0 to 70°C (WP90222L6)
 V_{CC} = 5.0 ±0.5 V, T_A = -40 to +85°C (WA-LSD, WP91397L6)

Parameter	Symbol	WA-LS		WP, WA-LSD		Units
		Min	Max	Min	Max	
Output Voltage, V _{CC} = 4.5 V (WA-LS), 4.75 V (WP, WA-LSD)						
Low, I _{OL} = 4.0 mA	V _{OL}	—	0.4	—	0.4	V
I _{OL} = 8.0 mA	V _{OL}	—	0.5	—	0.5	V
High, I _{OH} = -0.4 mA	V _{OH}	2.5	—	2.7	—	V
Input Voltage, V _{CC} = 4.5 V (WA-LS), 4.75 V (WP, WA-LSD)						
Low	V _{IL}	—	0.7	—	0.8*	V
High	V _{IH}	2.0	7.5	2.0	5.5	V
Clamp, I _{IN} = -18.0 mA	V _{IK}	—	-1.5	—	-1.5	V
Input Current, V _{CC} = 5.5 V (WA-LS), 5.25 V (WP, WA-LSD)						
Low, V _{IL} = 0.4 V	I _{IL}	—	-0.4	—	-0.4	mA
High, V _{IH} = 2.7 V	I _{IH}	—	20.0	—	20.0	μA
@ V _I max, V _I = 7.0 V (WA-LS), 5.5 V (WP, WA-LSD)	I _I	—	0.1	—	0.1	mA
Output Current, V _{CC} = 5.5 V (WA-LS), 5.25 V (WP, WA-LSD)						
Short-Circuit	I _{OS}	-20.0	-100.0	-20.0	-100.0	mA
Supply Current, V _{CC} = 5.5 V (WA-LS), 5.25 V (WP, WA-LSD)						
Output Low	I _{CC} L	—	3.3	—	3.3	mA
Output High	I _{CC} H	—	1.2	—	1.2	mA

* WA-LSD, WP91397L6: V_{IL} = 0.7 V

