

**HiRel K-Band GaAs Super Low Noise HEMT**

- **HiRel Discrete and Microwave Semiconductor**
- Conventional AlGaAs/GaAs HEMT  
(For new design we recommend to use our pseudo-morphic HEMT CFY67)
- For professional super low-noise amplifiers
- For frequencies from 500 MHz to > 20 GHz
- Hermetically sealed microwave package
- Super low noise figure, high associated gain
-  **ESA Space Qualified**  
ESA/SCC Detail Spec. No.: 5613/002,  
Type Variant No.s 01 to 04

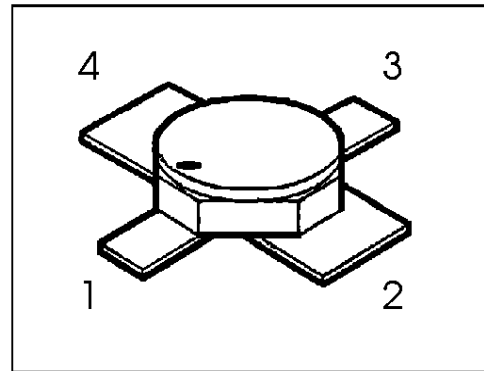

**ESD:** Electrostatic discharge sensitive device, observe handling precautions!

Type	Marking	Ordering Code	Pin Configuration				Package
			1	2	3	4	
CFY66-08 (ql)	-	see below	G	S	D	S	Micro-X
CFY66-08P (ql)							
CFY66-10 (ql)							
CFY66-10P (ql)							

CFY66-nnl: specifies gain and output power levels (see electrical characteristics)

(ql) Quality Level:	P: Professional Quality,	Ordering Code:	on request
	H: High Rel Quality,	Ordering Code:	on request
	S: Space Quality,	Ordering Code:	on request
	ES: ESA Space Quality,	Ordering Code:	on request

(see order instructions for ordering example)

## Maximum Ratings

Parameter	Symbol	Values	Unit
Drain-source voltage	$V_{DS}$	3.5	V
Drain-gate voltage	$V_{DG}$	4.5	V
Gate-source voltage (reverse / forward)	$V_{GS}$	- 3... + 0.5	V
Drain current	$I_D$	60	mA
Gate forward current	$I_G$	2	mA
RF Input Power, C- and X-Band <sup>1)</sup>	$P_{RF,in}$	+ 10	dBm
Junction temperature	$T_J$	150	°C
Storage temperature range	$T_{stg}$	- 65... + 150	°C
Total power dissipation <sup>2)</sup>	$P_{tot}$	200	mW
Soldering temperature <sup>3)</sup>	$T_{sol}$	230	°C

## Thermal Resistance

Junction-soldering point	$R_{thJS}$	≤ 515 (tbc.)	K/W
--------------------------	------------	--------------	-----

**Notes.:**

- 1) For  $V_{DS} \leq 2$  V. For  $V_{DS} > 2$  V, derating is required.
- 2) At  $T_s = + 47$  °C. For  $T_s > + 47$  °C derating is required.
- 3) During 15 sec. maximum. The same terminal shall not be resoldered until 3 minutes have elapsed.

**Electrical Characteristics** (at  $T_A=25\text{ }^\circ\text{C}$ ; unless otherwise specified)

Parameter	Symbol	Values			Unit
		min.	typ.	max.	
<b>DC Characteristics</b>					
Drain-source saturation current $V_{DS} = 2\text{ V}, V_{GS} = 0\text{ V}$	$I_{Dss}$	10	30	60	mA
Gate threshold voltage $V_{DS} = 2\text{ V}, I_D = 1\text{ mA}$	$-V_{Gth}$	0.2	0.7	2.0	V
Drain current at pinch-off $V_{DS} = 1.5\text{ V}, V_{GS} = -3\text{ V}$	$I_{Dp}$	-	< 50	-	$\mu\text{A}$
Gate leakage current at pinch-off $V_{DS} = 1.5\text{ V}, V_{GS} = -3\text{ V}$	$-I_{Gp}$	-	< 50	200	$\mu\text{A}$
Transconductance $V_{DS} = 2\text{ V}, I_D = 10\text{ mA}$	$g_{m10}$	40	55	-	mS
Gate leakage current at operation $V_{DS} = 2\text{ V}, I_D = 10\text{ mA}$	$-I_{G10}$	-	< 0.5	2	$\mu\text{A}$
Thermal resistance junction to soldering point	$R_{thJS}$	-	450	-	K/W

## Electrical Characteristics (continued)

Parameter	Symbol	Values			Unit
		min.	typ.	max.	
<b>AC Characteristics</b>					
Noise figure <sup>1)</sup> $V_{DS} = 2 \text{ V}, I_D = 10 \text{ mA}, f = 12 \text{ GHz}$ CFY66-08, -08P CFY66-10, 10P	NF	- -	0.7 0.9	0.8 1.0	dB
Associated gain. <sup>1)</sup> $V_{DS} = 2 \text{ V}, I_D = 10 \text{ mA}, f = 12 \text{ GHz}$ CFY66-08, -08P CFY66-10, 10P	$G_a$	10.0 9.5	11.0 10.5	- -	dB
Output power at 1 dB gain compression <sup>2)</sup> $V_{DS} = 2 \text{ V}, I_D = 20 \text{ mA}, f = 12 \text{ GHz}$ CFY66-06, -08, -10 CFY66-08P, -10P	$P_{1dB}$	- 10.0	11.0 11.0	- -	dBm

### Notes.:

1) Noise figure / associated gain characteristics given for minimum noise figure matching conditions (fixed generic matching, no fine-tuning).

2) Output power characteristics given for optimum output power matching conditions (fixed generic matching, no fine-tuning).

**Typical Common Source S-Parameters**

CFY66-08 $V_{GS} = 2\text{ V}$ , $I_D = 10\text{ mA}$ , $Z_0 = 50\ \Omega$											
f	S11	<S11	S21	<S21	S12	<S12	S22	<S22	k-Fact.	$S_{21}/S_{12}$	MAG
[GHz]	[magn]	[angle]	[magn]	[angle]	[magn]	[angle]	[magn]	[angle]	[magn]	[dB]	[dB]
1,0	0,990	-21	4,451	161	0,0260	70	0,649	-16	0,14	22,3	
2,0	0,960	-39	4,282	144	0,0460	61	0,623	-29	0,19	19,7	
3,0	0,920	-57	4,148	126	0,0650	49	0,589	-43	0,27	18,0	
4,0	0,880	-77	3,979	108	0,0830	37	0,560	-57	0,32	16,8	
5,0	0,830	-95	3,727	93	0,0940	25	0,532	-70	0,39	16,0	
6,0	0,790	-111	3,444	78	0,1000	14	0,506	-83	0,47	15,4	
7,0	0,749	-124	3,206	64	0,1060	6	0,490	-94	0,55	14,8	
8,0	0,720	-137	3,029	50	0,1110	-3	0,463	-103	0,63	14,4	
9,0	0,690	-150	2,907	38	0,1130	-11	0,440	-113	0,70	14,1	
10,0	0,670	-165	2,845	25	0,1190	-20	0,420	-121	0,74	13,8	
11,0	0,649	179	2,787	11	0,1210	-28	0,400	-130	0,79	13,6	
12,0	0,628	164	2,699	-3	0,1200	-37	0,385	-143	0,84	13,5	
13,0	0,610	151	2,614	-16	0,1200	-46	0,370	-153	0,91	13,4	
14,0	0,597	138	2,584	-28	0,1190	-55	0,355	-162	0,96	13,4	
15,0	0,584	121	2,550	-42	0,1180	-66	0,340	-172	1,01	13,3	12,8
16,0	0,580	104	2,484	-56	0,1170	-76	0,330	178	1,05	13,3	11,9
17,0	0,580	89	2,461	-71	0,1150	-87	0,325	169	1,08	13,3	11,5
18,0	0,580	74	2,456	-86	0,1160	-100	0,320	160	1,09	13,3	11,4

**Typical Common Source Noise-Parameters**

CFY66-08 $V_{GS} = 2\text{ V}$ , $I_D = 10\text{ mA}$ , $Z_0 = 50\ \Omega$				
f	NF <sub>min</sub>	$ \Gamma_{opt} $	< $\Gamma_{opt}$	$R_n$
[GHz]	[dB]	[magn]	[angle]	[ $\Omega$ ]
1	0,27	0,770	16	17,85
2	0,31	0,720	30	16,55
3	0,35	0,672	43	15,27
4	0,38	0,634	57	13,75
5	0,42	0,604	71	11,99
6	0,46	0,578	85	10,04
7	0,50	0,558	100	8,15
8	0,55	0,541	114	6,30
9	0,60	0,528	128	4,74
10	0,65	0,517	143	3,45
11	0,70	0,506	157	2,58
12	0,74	0,496	171	2,16
13	0,79	0,485	-175	2,27
14	0,85	0,472	-160	2,88
15	0,89	0,457	-146	3,99
16	0,95	0,437	-132	5,59
17	1,00	0,415	-118	7,63
18	1,06	0,389	-102	9,96

**Order Instructions:**

Full type variant including quality level must be specified by the orderer. For *HiRel* Discrete and Microwave Semiconductors the ordering code specifies device family and quality level only.

## Ordering Form:

Ordering Code: Q.....  
CFY66 -(nnl) (ql)  
          -(nnl)       Noise Figure/Gain and/or Power Level  
          (ql):       Quality Level

## Ordering Example:

Ordering Code: (on request)  
CFY66-08P ES  
  
For CFY66, Noise Figure/Gain/Power Level 08P:  
          NF < 0.8 dB,  $G_a > 10.0$  dB,  $P_{1dB} > 10$  dBm @ 12 GHz  
in ESA Space Quality Level

**Further Informations:**

See our WWW-Pages:

- Discrete and RF-Semiconductors (Small Signal Semiconductors)

[www.siemens.de/semiconductor/products/35/35.htm](http://www.siemens.de/semiconductor/products/35/35.htm)

- *HiRel* Discrete and Microwave Semiconductors

[www.siemens.de/semiconductor/products/35/353.htm](http://www.siemens.de/semiconductor/products/35/353.htm)

Please contact also our marketing division :

Tel.:       ++89 6362 4480  
Fax.:       ++89 6362 5568  
e-mail:     martin.wimmers@siemens-scg.com  
Address:    Siemens Semiconductors,  
            High Frequency Products Marketing,  
            P.O.Box 801709,  
            D-81617 Munich

