



Explanation of Part Number

WPSMLBLN **XXXX** **X**
 (1) (2) (3)

- (1) **Product Series** WPSMLBLN
- (2) **Product Type**
 001B: 50Ω with Frequency Range 2400-2500MHz
 002B: 100Ω with Frequency Range 2400-2500MHz
 003B: 200Ω with Frequency Range 2400-2500MHz
 004A: 50Ω with Frequency Range 5150-5875MHz
 005A: 100Ω with Frequency Range 5150-5875MHz
 006A: 200Ω with Frequency Range 5150-5875MHz
- (3) **Packaging Code**
 Blank: Bulk
 K: 7" Reel, 1000 pieces per reel

PRELIMINARY SPECIFICATION

Subject to change without notice

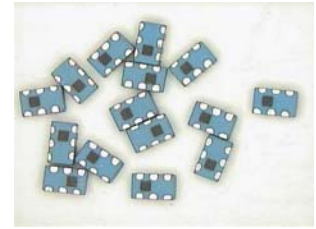

Quick Reference Data

Product Type	001B	002B	003B	004A	005A	006A
Balanced Impedance	50Ω	100Ω	200Ω	50Ω	100Ω	200Ω
Frequency Range	2400-2500MHz			5150-5875MHz		
Unbalanced Impedance	50Ω					
Insertion Loss	1dB (max)					
Phase Difference	180 ± 10 degrees					
Amplitude Difference	2dB (max)					
Operating Temperature	-40 ~ +85°C					
VSWR	2.0 max					
Dimension	2.0 x 1.25 x 0.85 mm					

Applications

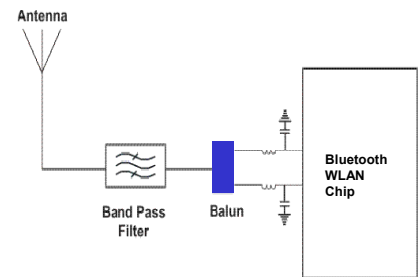

Dimensional Data

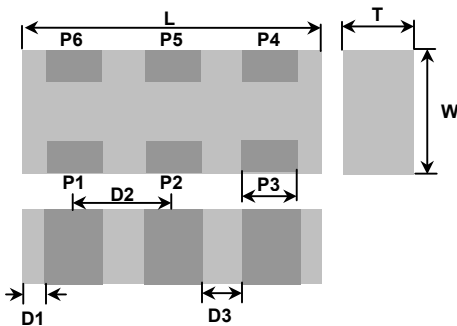



Dimension		Port
L	2.00 ± 0.10 mm	-
W	1.25 ± 0.10 mm	-
T	0.85 ± 0.10 mm	-
P1	0.30 ± 0.15 mm	Unbalanced Port
P2	0.30 ± 0.15 mm	Ground or DC
P3	0.30 ± 0.15 mm	Balanced Port
P4	0.30 ± 0.15 mm	Balanced Port
P5	0.30 ± 0.15 mm	Ground
P6	0.30 ± 0.15 mm	Not Connect
D1	0.20 ± 0.10 mm	-
D2	0.65 ± 0.15 mm	-
D3	0.35 ± 0.15 mm	-

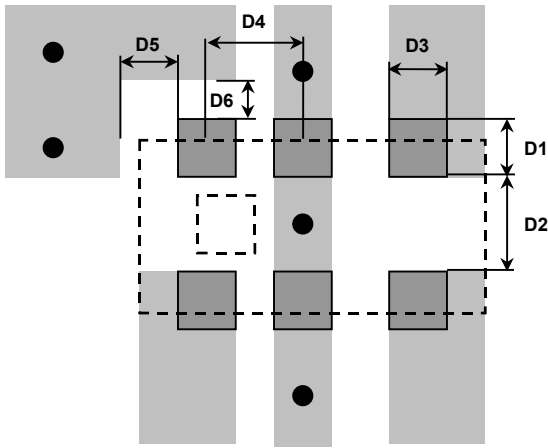

Recommended PCB Pattern



Dimension	Value	Port
D1	1.00 ± 0.10 mm	-
D2	0.80 ± 0.10 mm	-
D3	0.35 ± 0.10 mm	-
D4	0.65 ± 0.10 mm	-
D5	0.25 ± 0.10 mm	-
D6	0.25 ± 0.10 mm	-
	-	Land
	-	Through hole

Test Circuits

Phase Balance and Amplitude Balance

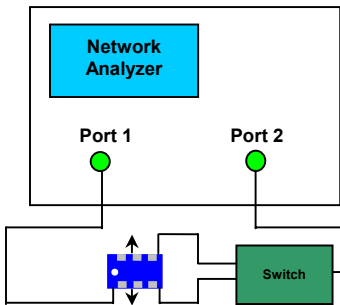

Return Loss (S11) and Insertion Loss (S21)

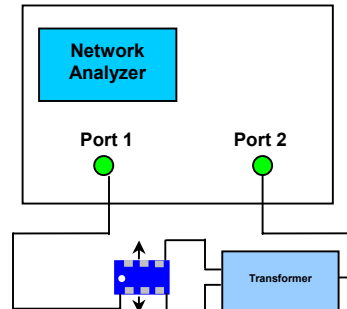

Frequency Characteristics

Below figures apply to 001B, 002B, 003B series.

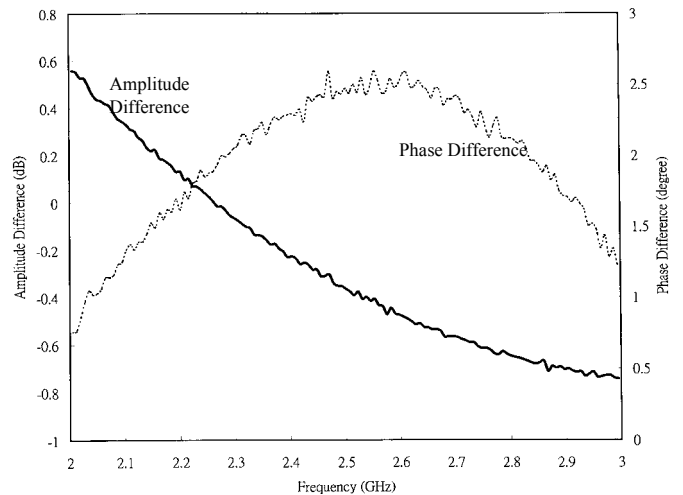
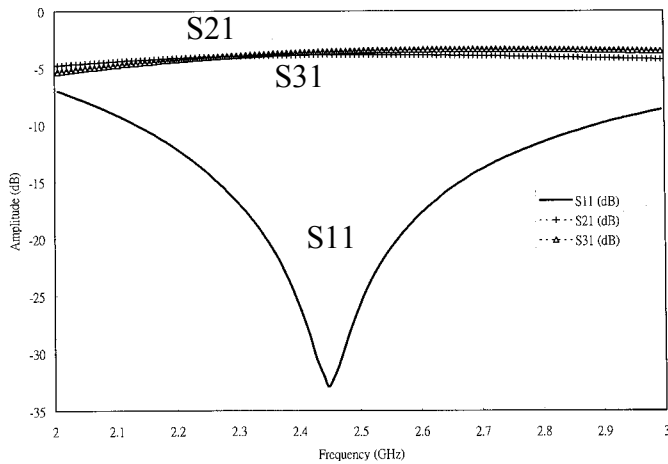



Reliability Data (Reference to IEC Specification)

IEC 384-10/ CECC 32 100 CLAUSE	IEC 60068-2 TEST METHOD	TEST	PROCEDURE	REQUIREMENTS
4.4		Mounting	The Balun can be mounted on printed-circuit boards or ceramic substrates by applying wave soldering, reflow soldering (including vapour phase soldering) or conductive adhesive.	No visible damage.
4.5		Visual inspection and dimension check	Any applicable method using x 10 magnification.	In accordance with specification (chip off 1mm).
4.6.1		Balun	VSWR < 2 at 20°C.	Standard test board.
4.8		Adhesion	A force of 3N applied for 10 sec. to the line joining the terminations and in a plane parallel to the substrate.	No visible damage.
4.9		Bond strength of plating on end face	Mounted in accordance with CECC 32 100, paragraph 4.4.	No visible damage.
			Conditions: bending 0.5mm at a rate of 1mm/sec., radius jig. 340mm, 2mm warp on FR4 board of 90mm length.	No visible damage.
4.10	20(Tb)	Resistance to soldering heat	260 ± 5°C for 10 ± 0.5 sec. in a static solder bath.	No visible damage and complies with electrical performance.
		Resistance to leaching	260 ± 5°C for 30 ± 1 sec. in a static solder bath.	Using visual enlargement of x 10, dissolution of the termination shall not exceed 10%.
4.11	20(Ta)	Solderability	Zero hour test, and test after storage (20 to 24 months) in original atmosphere; un-mounted chips completely immersed for 2 ± 0.5 sec. in 235 ± 5°C.	Termination must be at least 75% is well tinned at termination.
4.12	4(Na)	Rapid change of temperature	-40°C (30 minutes) to +85°C (30 minutes); 200 cycles.	No visible damage and complies with electrical performance.
4.14	3(Ca)	Damp heat	500 ± 12 hours at 60°C; 90 to 95% RH.	No visible damage and complies with electrical performance.
4.15		Endurance	500 ± 12 hours at 85°C.	No visible damage and complies with electrical performance.



Carrier Taping Specification

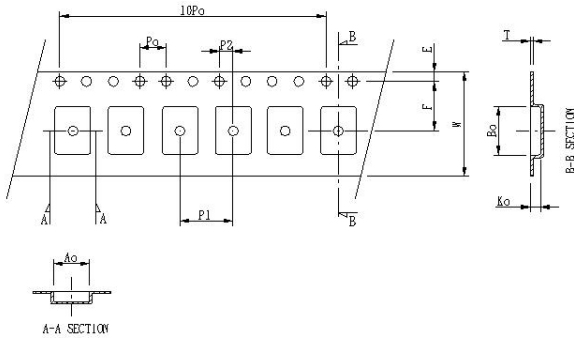

Dimension

Serial No.	Checking note	Index	Spec(mm)
1	Sprocket hole	Do	1.50 ± 0.10
2	Pocket hole	D1	1
3	Distance sprocket hole/sprocket hole	Po	4.00 ± 0.10
4	Distance pocket/pocket	P1	4.00 ± 0.10
5	Distance sprocket hole/pocket	P2	2.00 ± 0.10
6	Tape width	W	8.10 ± 0.20
7	Distance sprocket hole/outside	E	1.75 ± 0.10
8	Distance sprocket hole/pocket	F	3.5 ± 0.05
9	Pocket length nominal clearance	Ao	0.20
10	Pocket length nominal clearance	Bo	0.20
11	Pocket depth minimum clearance	Ko	0.05
12	Thickness of tape	T	0.22 ± 0.05
13	10x sprocket hole pitch	10Po	40.0 ± 0.20

7”(180mm) Reel Specifications

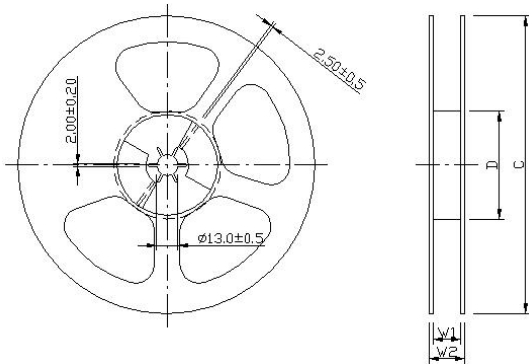

Product size code	Units per Reel	Tape Width (mm)	C (mm)	D (mm)	W ₁ (mm)	W ₂ (mm)
Balun	4000	8	180.0 ± 1.0	62 ± 1.5	8.4 + 0.15	14.4 max