

450-V, 30-A, 175-W Silicon N-P-N Switching Transistors

For Switching Applications in Industrial and Commercial Equipment

Features:

- High voltage ratings:
 $V_{CE0} = 450\text{ V (2N6251)}$
 375 V (2N6250)
 300 V (2N6249)
- High dissipation rating:
 $P_T = 175\text{ W}$
- Low saturation voltages
- Maximum safe-area-of-operation curves

The 2N6249, 2N6250 and 2N6251 are multiple epitaxial silicon n-p-n power transistors. Multiple-epitaxial construction maximizes the volt-ampere characteristic of the device and provides fast switching speeds.

These devices use the popular JEDEC TO-204AA package; they differ mainly in voltage ratings, leakage-current limits, and $V_{CE(sat)}$ ratings.

The exceptional second-breakdown capabilities and high voltage-breakdown ratings make these transistors especially suitable for offline inverters, switching regulators motor controls, and deflection circuit applications.

The high gain and high $E_{S,b}$ energy-handling capability of the 2N6249 make it an excellent choice for motor-control applications in which large winding inductances are encountered and high surge currents are required to start the motor.

The high breakdown voltages, low saturation voltages, and fast-switching capability of the 2N6250 and 2N6251 make them especially suitable for inverter circuits operating directly off the rectified 115-V power line or a bridge configuration operating from the rectified 220-V line.

TERMINAL DESIGNATIONS

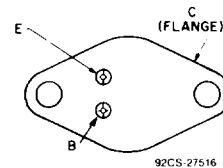

JEDEC TO-213AA

2
POWER TRANSISTORS

MAXIMUM RATINGS, Absolute-Maximum Values:

	2N6249	2N6250	2N6251	
* V_{CE0}	300	375	450	V
$V_{CE0(SUS)}$	200	275	350	V
* $V_{CEX(SUS)} (V_{BE} = 0\text{ V})$	225	300	375	V
$V_{CER(SUS)} (R_{BE}) \leq 50\ \Omega$	225	300	375	V
* V_{EBO}	6	6	6	V
* I_C	10	10	10	A
I_{CM}	30	30	30	A
* I_B	10	10	10	A
* P_T				W
At T_C up to 25°C and V_{CE} up to 30 V	175	175	175	
At T_C up to 25°C and V_{CE} above 30 V	Derate Linearly at 1 _____			°C/W
* T_J, T_{stg}	-65 to +200			°C
* T_L				°C
At distances $\geq 1/32$ in. (0.8 mm) from case for 10 s max.	230			

* 2N-Series types in accordance with JEDEC registration data format (JS-6, RDF-1).

2N6249, 2N6250, 2N6251

ELECTRICAL CHARACTERISTICS, At Case Temperature (T_C) = 25°C Unless Otherwise Specified

CHARACTERISTIC	TEST CONDITIONS						LIMITS						UNITS
	DC VOLTAGE (V)	DC CURRENT (A)		2N6249			2N6250			2N6251			
		I_C	I_B	MIN.	TYP.	MAX.	MIN.	TYP.	MAX.	MIN.	TYP.	MAX.	
				V_{CE}									
I_{CEO}	150 225 300		0 0 0	- - -	- - -	5 - -	- - -	- - -	5 - -	- - -	- - -	5 - -	mA
* I_{CEV} $V_{BE} = -1.5$	225 300 375			- - -	- - -	5 - -	- - -	- - -	5 - -	- - -	- - -	5 - -	
* I_{CEV} $V_{BE} = -1.5$ $T_C = 125^\circ C$	225 300 375			- - -	- - -	10 - -	- - -	- - -	10 - -	- - -	- - -	10 - -	
* I_{EBO} $V_{BE} = -6$				- - -	- - -	1 - -	- - -	- - -	1 - -	- - -	- - -	1 - -	mA
* $V_{CEO(sus)}$		0.2		200 ^b	- - -	- - -	275 ^b	- - -	- - -	350 ^b	- - -	- - -	V
* $V_{CER(sus)}$ $R_{BE} = 50 \Omega$		0.2		225 ^b	- - -	- - -	300 ^b	- - -	- - -	375 ^b	- - -	- - -	V
* V_{EBO} $I_E = 1 \text{ mA}$				6	- - -	- - -	6	- - -	- - -	6	- - -	- - -	V
* h_{FE}	3	10 ^a		10	- - -	- - -	50	- - -	- - -	- - -	- - -	- - -	
	3	10 ^a		-	- - -	- - -	8	- - -	- - -	50	- - -	- - -	
	3	10 ^a		-	- - -	- - -	-	- - -	- - -	6	- - -	50	
* $V_{BE(sat)}$		10 ^a	1	-	- - -	- - -	2.25	- - -	- - -	-	- - -	-	V
		10 ^a	1.25	-	- - -	- - -	-	- - -	- - -	2.25	- - -	-	
		10 ^a	1.67	-	- - -	- - -	-	- - -	- - -	-	- - -	2.25	
* $V_{CE(sat)}$		10 ^a	1	-	- - -	- - -	1.5	- - -	- - -	-	- - -	-	V
		10 ^a	1.25	-	- - -	- - -	-	- - -	- - -	1.5	- - -	-	
		10 ^a	1.67	-	- - -	- - -	-	- - -	- - -	-	- - -	1.5	
* $ h_{fe} $ $f = 1 \text{ MHz}$	10	1		2.5	8	-	2.5	8	-	2.5	8	-	
* I_S/b $t_p = 1 \text{ s nonrep.}$	30			5.8	-	-	5.8	-	-	5.8	-	-	A
* E_S/b $V_{BE} = -4$ $R_B = 50 \Omega$ $L = 50 \mu H$		10 ^c		2.5	-	-	2.5	-	-	2.5	-	-	mJ
* t_r $V_{CC} = 200 \text{ V}$ $I_{B1} = -I_{B2}$		10	1	-	0.8	2	-	-	-	-	-	-	
		10	1.25	-	-	-	-	0.8	2	-	-	-	
		10	1.67	-	-	-	-	-	-	-	0.8	2	
* t_s $V_{CC} = 200 \text{ V}$ $I_{B1} = -I_{B2}$		10	1	-	1.8	3.5	-	-	-	-	-	-	μs
		10	1.25	-	-	-	-	1.8	3.5	-	-	-	
		10	1.67	-	-	-	-	-	-	-	1.8	3.5	
* t_f $V_{CC} = 200 \text{ V}$ $I_{B1} = -I_{B2}$		10	1	-	0.5	1	-	-	-	-	-	-	
		10	1.25	-	-	-	-	0.5	1	-	-	-	
		10	1.67	-	-	-	-	-	-	-	0.5	1	
* $R_{\theta JC}$	10	5		-	-	1	-	-	1	-	-	1	°C/W

* 2N-Series types in accordance with JEDEC registration data format (JS-6 RDF-1).

a Pulsed; pulse duration $\leq 300 \mu s$, duty factor = 2%.

b CAUTION: The sustaining voltages $V_{CEO(sus)}$ and $V_{CER(sus)}$ MUST NOT be measured on a curve tracer.

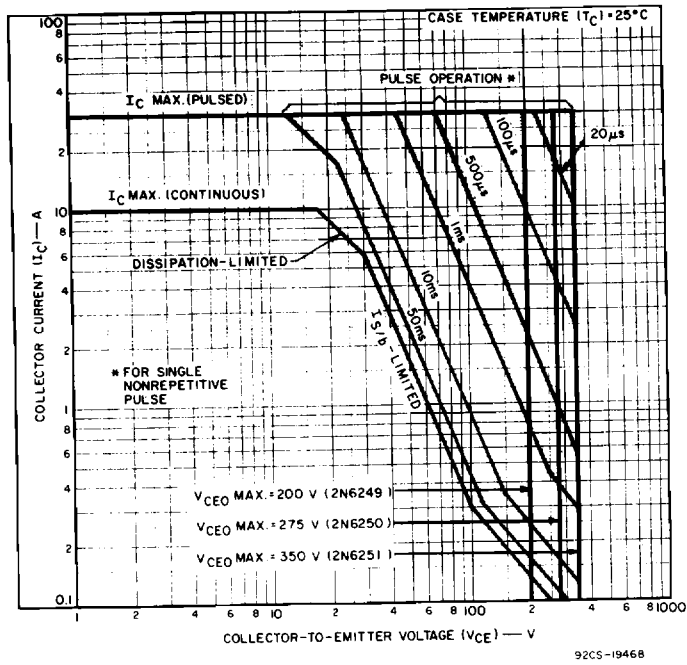

Fig. 1 - Maximum operating areas for all types at $T_c = 25^\circ\text{C}$.

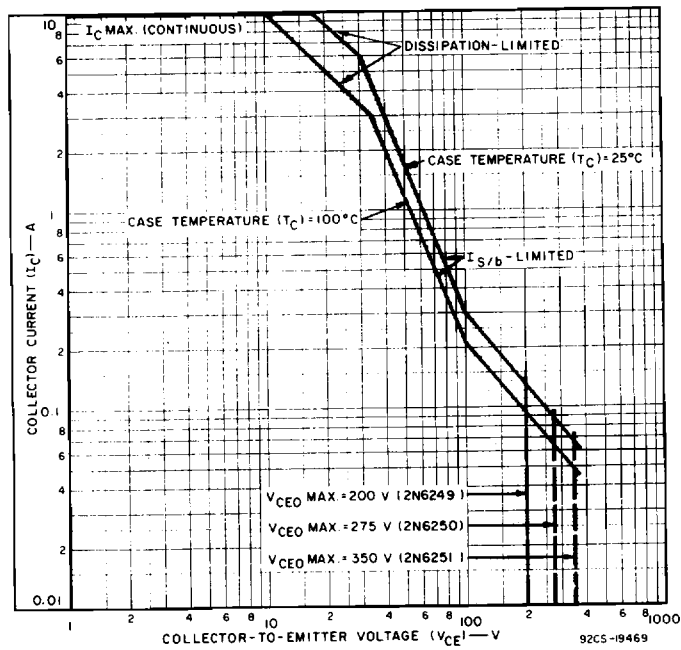

Fig. 2 - Maximum operating areas for all types at $T_c = 100^\circ\text{C}$.

2N6249, 2N6250, 2N6251

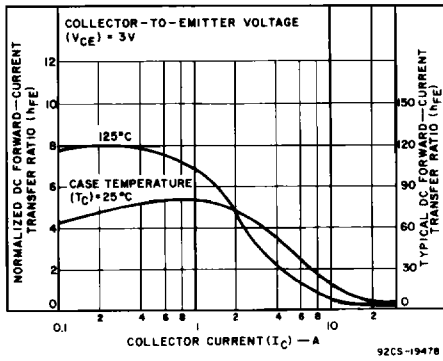

Fig. 3 - Typical normalized dc beta characteristics for all types.

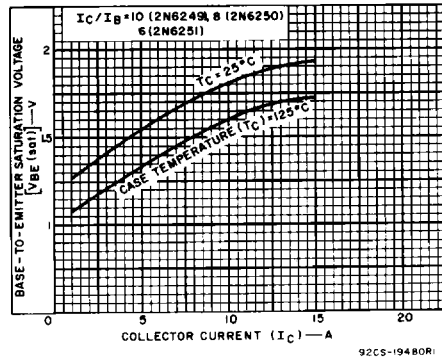

Fig. 4 - Typical base-to-emitter saturation voltage characteristics for all types.

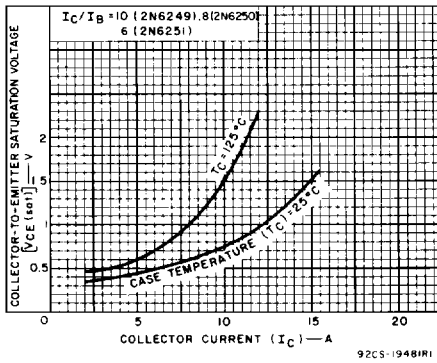

Fig. 5 - Typical collector-to-emitter saturation voltage characteristics for all types.

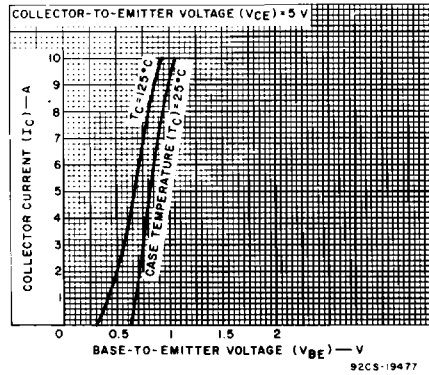

Fig. 6 - Typical transfer characteristics for all types.

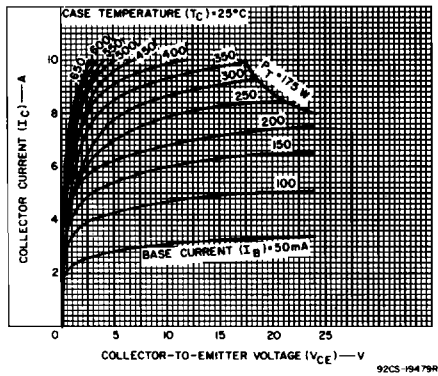

Fig. 7 - Typical output characteristics for all types.

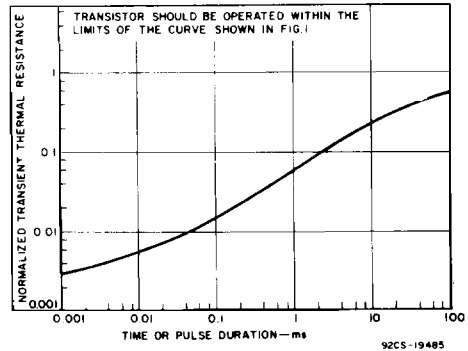

Fig. 8 - Typical thermal response characteristics for all types.

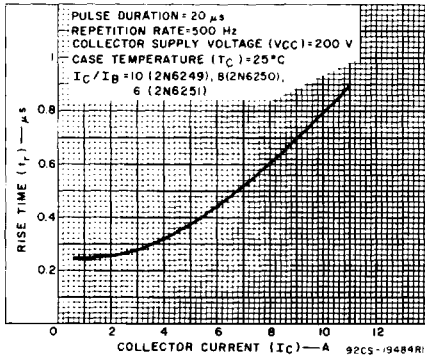

Fig. 9 - Typical rise-time characteristics for all types.

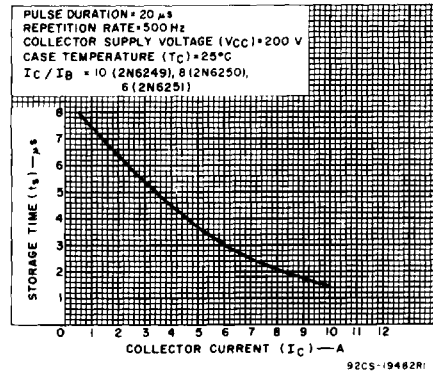

Fig. 10 - Typical storage-time characteristics for all types (with constant forced gain).

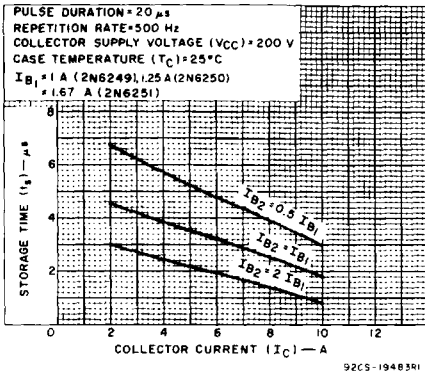

Fig. 11 - Typical storage-time characteristics for all types (with constant base drive).

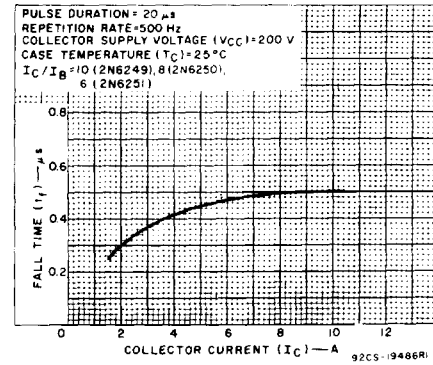

Fig. 12 - Typical fall-time characteristic for all types.

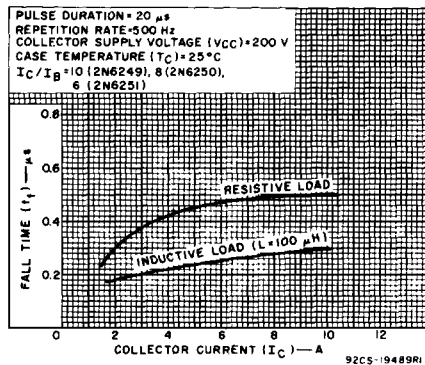

Fig. 13 - Typical inductive- and resistive-load fall-time characteristics for all types.

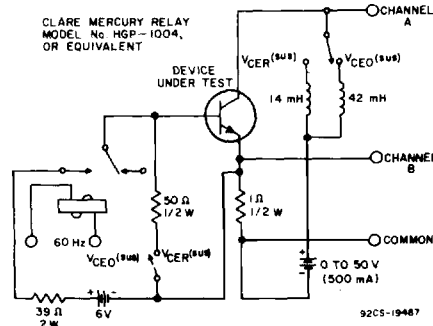
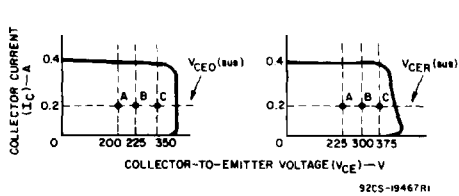

Fig. 14 - Circuit used to measure sustaining voltage $V_{CE0(sus)}$ and $V_{CEr(sus)}$ for all types.

2N6249, 2N6250, 2N6251



The sustaining voltages $V_{CEO(sus)}$ and $V_{CER(sus)}$ are acceptable when the traces fall to the right of point "A" for type 2N6249, point "B" for type 2N6250, and point "C" for type 2N6251 ($I_C = 0.2$ A).

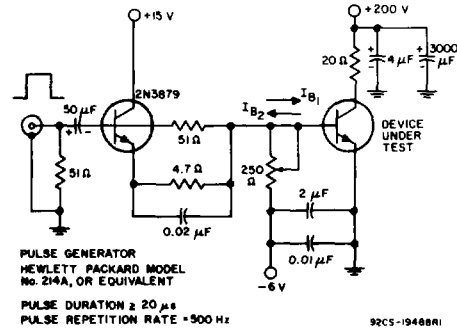

Fig. 15 - Oscilloscope display for measurement of sustaining voltages.

Fig. 16 - Circuit used to measure switching times for all types.

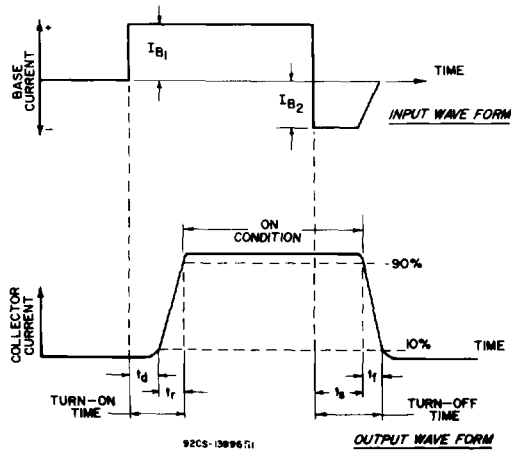

Fig. 17 - Phase relationship between input and output currents showing reference points for specifications of switching times.

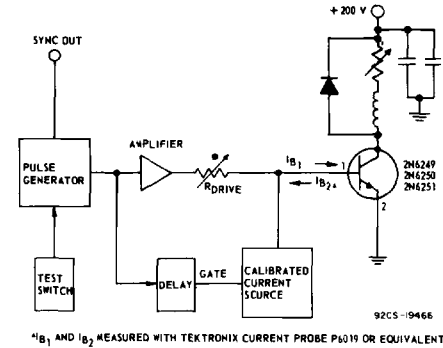

Fig. 18 - Circuit used to measure inductive-load switching times for all types.