

High-performance 5-channel video driver IC for DVD players BH7865FS

● Description

BH7865FS is a 5-channel video driver IC developed for DVD player/recorder. Special filters adjusted to each band of various video signals are incorporated into a single chip. High definition, size reduction and high cost performance can be achieved in DVD players.

● Dimension (Unit : mm)

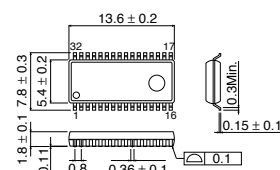

SSOP-A32

● Features

- 1) Each high-performance filter, 6dB amplifier, and 75Ω driver for DVD are incorporated into a single chip.
- 2) Drive 5ch (Y, C, MIX, Cb, Cr)
- 3) Group delay difference between chroma signal and luminance signal is a small number of nsec.
- 4) Drive 2 lines of each signal
- 5) Operating by 5V single power supply
- 6) Built-in mute circuit

● Applications

DVD players, DVD recorders

● Absolute Maximum Ratings (Ta=25°C)

Parameter	Symbol	Limits	Unit
Applied Voltage	Vcc max.	6.0	V
Power dissipation	Pd	0.95	W
Operating temperature range	Topr	-10 ~ +70	°C
Storage temperature range	Tstg	-55 ~ +150	°C

* Derating : -7.6mW/°C for operation above Ta=25°C

* PCB (70mmx70mm,t=1.6mm) glass epoxy mounting.

● Recommended Operating Conditions (Ta=25°C)

Parameter	Symbol	Min.	Typ.	Max.	Unit
Power supply voltage	Vcc	4.5	-	5.5	V

● Electrical characteristics (Unless otherwise noted; Ta=25°C, Vcc=5V)

Parameter	Symbol	Min.	Typ.	Max.	Unit	Conditions
Maximum output level	V _{OM}	2.6	3.0	–	V _{pp}	CIN:f=3.58MHz, YIN,CbIN,CrIN:f=1MHz*1
Frequency characteristic1(C)	G _{FC}	-2.0	0	2.0	dB	CIN:f=1.5/3.58MHz,6/3.58MHz,1Vpp
Frequency characteristic1(MIX1)	G _{FMIX1}					CIN:f=1.5/3.58MHz,6/3.58MHz,1Vpp
Frequency characteristic1(MIX2)	G _{FMIX2}					YIN:f=6/1MHz,1Vpp
Frequency characteristic1(Y)	G _{FY}					YIN:f=6/1MHz,1Vpp
Frequency characteristic1(Cb)	G _{FCb}					CbIN:f=3/1MHz,1Vpp
Frequency characteristic1(Cr)	G _{FCr}					CrIN:f=3/1MHz,1Vpp
Mute attenuation	M _T	–	-50	–	dB	CIN:f=3.58MHz, 1Vpp YIN,CbIN,CrIN:f=1MHz,1Vpp
Input impedance	Z _{IN}	16	20	24	kΩ	CIN,CbIN,CrIN input pin *2

● Electrical characteristics (Unless otherwise noted; Ta=25°C, Vcc=5V)

Parameter	Symbol	Min.	Typ.	Max.	Unit	Conditions
Voltage gain (C)	G _{VC}	5.0	6.0	7.0	dB	CIN:f=3.58MHz, 1Vpp
Voltage gain MIX (C)	G _{VMIXC}					CIN:f=3.58MHz, 1Vpp
Voltage gain MIX (Y)	G _{VMIXY}					YIN:f=1MHz,1Vpp
Voltage gain (Y)	G _{VY}					YIN:f=1MHz,1Vpp
Voltage gain (Cb)	G _{VCb}					CbIN:f=1MHz,1Vpp
Voltage gain (Cr)	G _{VCr}					CrIN:f=1MHz,1Vpp
Group delay characteristic Y ↔ C	ΔGD ₁					–
Group delay characteristic Y ↔ Cb (Cr)	ΔGD ₂	–	5.0	–	nsec	YIN:f=1MHz, Vin=1Vpp, CbIN(CrIN):f=1MHz Vin=1Vpp, difference between Y and Cb(Cr) of GD

*The input level is adjusted to make the output tertiary distortion -30dB by adding the sine-wave of f=1MHz to the input VIN.

At this input level, Maximum output level of output voltage is V_{OM} (Vpp).

*The input voltage VIN50(V) and the input open voltage VIN(V) is measured when current of 50 μA is inputted to each input CIN, CbIN and CrIN.

At this level, the input impedance ZIN is ZIN=VIN50-VIN/50 μA (kΩ).

● Application circuit

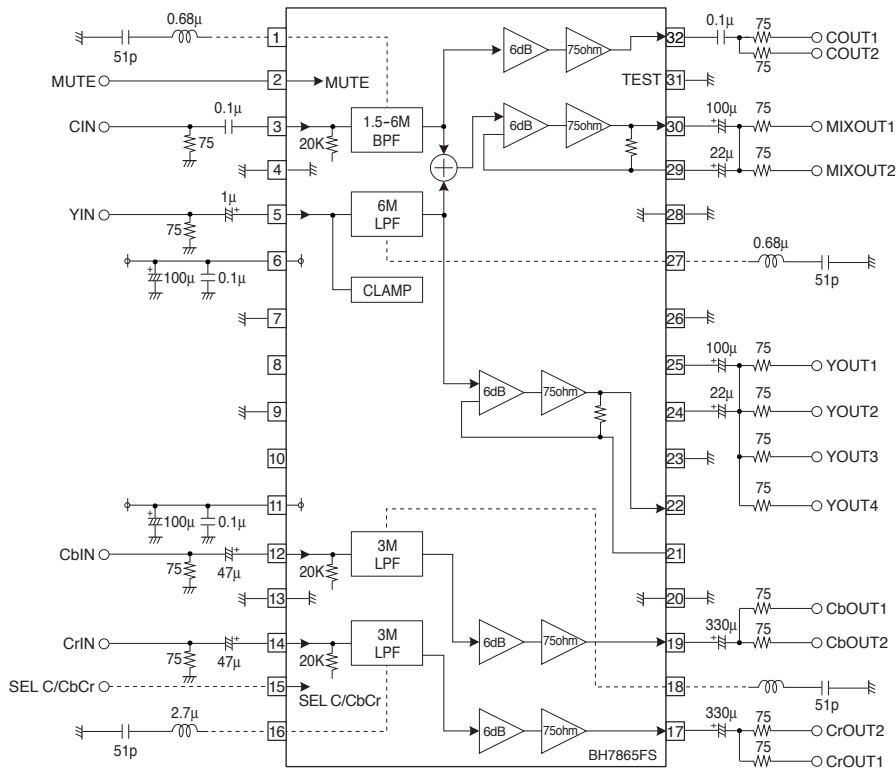

Notes

- No technical content pages of this document may be reproduced in any form or transmitted by any means without prior permission of ROHM CO.,LTD.
- The contents described herein are subject to change without notice. The specifications for the product described in this document are for reference only. Upon actual use, therefore, please request that specifications to be separately delivered.
- Application circuit diagrams and circuit constants contained herein are shown as examples of standard use and operation. Please pay careful attention to the peripheral conditions when designing circuits and deciding upon circuit constants in the set.
- Any data, including, but not limited to application circuit diagrams information, described herein are intended only as illustrations of such devices and not as the specifications for such devices. ROHM CO.,LTD. disclaims any warranty that any use of such devices shall be free from infringement of any third party's intellectual property rights or other proprietary rights, and further, assumes no liability of whatsoever nature in the event of any such infringement, or arising from or connected with or related to the use of such devices.
- Upon the sale of any such devices, other than for buyer's right to use such devices itself, resell or otherwise dispose of the same, no express or implied right or license to practice or commercially exploit any intellectual property rights or other proprietary rights owned or controlled by
- ROHM CO., LTD. is granted to any such buyer.
- Products listed in this document use silicon as a basic material.
Products listed in this document are no antiradiation design.

The products listed in this document are designed to be used with ordinary electronic equipment or devices (such as audio visual equipment, office-automation equipment, communications devices, electrical appliances and electronic toys).

Should you intend to use these products with equipment or devices which require an extremely high level of reliability and the malfunction of which would directly endanger human life (such as medical instruments, transportation equipment, aerospace machinery, nuclear-reactor controllers, fuel controllers and other safety devices), please be sure to consult with our sales representative in advance.

About Export Control Order in Japan

Products described herein are the objects of controlled goods in Annex 1 (Item 16) of Export Trade Control Order in Japan.

In case of export from Japan, please confirm if it applies to "objective" criteria or an "informed" (by MITI clause) on the basis of "catch all controls for Non-Proliferation of Weapons of Mass Destruction.