

Contents

TMP19A64F20AXBG

1. · Overview and Features
2. · Pin Layout and Pin Functions
3. · Flash Memory Operation
4. · Electrical Characteristics

32-bit RISC Microprocessor - TX19 Family

TMP19A64F20AXBG

1. Overview and Features

The TX19 family is a high-performance 32-bit RISC processor series that TOSHIBA originally developed by integrating the MIPS16™ASE (Application Specific Extension), which is an extended instruction set of high code efficiency.

TMP19A64 is a 32-bit RISC microprocessor with a TX19A processor core and various peripheral functions integrated into one package. It can operate at low voltage with low power consumption.

Features of TMP19A64 are as follows:

(1) TX19A processor core

1) Improved code efficiency and operating performance have been realized through the use of two ISA (Instruction Set Architecture) modes - 16- and 32-bit ISA modes.

- The 16-bit ISA mode instructions are compatible with the MIPS16™ASE instructions of superior code efficiency at the object level.
- The 32-bit ISA mode instructions are compatible with the TX39 instructions of superior operating performance at the object level.

2) Both high performance and low power consumption have been achieved.

● High performance

- Almost all instructions can be executed with one clock.
- High performance is possible via a three-operand operation instruction.
- 5-stage pipeline
- Built-in high-speed memory
- DSP function: A 32-bit multiplication and accumulation operation can be executed with one clock.

● Low power consumption

- Optimized design using a low power consumption library
- Standby function that stops the operation of the processor core

3) High-speed interrupt response suitable for real-time control

- Independency of the entry address
- Automatic generation of factor-specific vector addresses
- Automatic update of interrupt mask levels

● TOSHIBA is continually working to improve the quality and reliability of its products. Nevertheless, semiconductor devices in general can malfunction or fail due to their inherent electrical sensitivity and vulnerability to physical stress. It is the responsibility of the buyer, when utilizing TOSHIBA products, to comply with the standards of safety in making a safe design for the entire system, and to avoid situations in which a malfunction or failure of such TOSHIBA products could cause loss of human life, bodily injury or damage to property.

In developing your designs, please ensure that TOSHIBA products are used within specified operating ranges as set forth in the most recent TOSHIBA products specifications. Also, please keep in mind the precautions and conditions set forth in the "Handling Guide for Semiconductor Devices," or "TOSHIBA Semiconductor Reliability Handbook," etc.

- The products described in this document are subject to the foreign exchange and foreign trade laws.
- The information contained herein is presented only as a guide for the applications of our products. No responsibility is assumed by TOSHIBA for any infringements of patents or other rights of the third parties which may result from its use. No license is granted by implication or otherwise under any patent or patent rights of TOSHIBA or others.
- The information contained herein is subject to change without notice

(2) On Chip program memory and data memory

Product name	On chip ROM	On chip RAM
TMP19A64F20AXBG	2 Mbytes (Flash)	64 Kbytes
TMP19A64C1DXBG	1.5 Mbytes	56 Kbytes

- ROM correction function: 1 word \times 8 blocks, 8 words \times 4 blocks
- Backup RAM: 512 bytes

(3) External memory expansion

- 16-Mbyte off-chip address for code and data
- External data bus:
Separate bus/multiplexed bus : Dynamic bus sizing for 8- and 16-bit widths ports.
- Chip select/wait controller : 6 channels

(4) DMA controller : 8 channels

- Data to be transferred to internal memory, internal I/O, external memory, and external I/O

(5) 16-bit timer : 11 channels

- 16-bit interval timer mode
- 16-bit event counter mode
- 16-bit PPG output
- Event capture function
- 2-phase pulse input counter function (1 channel assigned to perform this function):
Multiplication-by-4 mode

(6) 32-bit timer

- 32-bit input capture register : 4 channels
- 32-bit compare register : 10 channels
- 32-bit time base timer : 1 channel

(7) Clock timer : 1 channel

(8) General-purpose serial interface: 7 channels

- Either UART mode or synchronous mode can be selected.

(9) Serial bus interface : 1 channel

- Either I²C bus mode or clock synchronous mode can be selected

(10) 10-bit A/D converter with (S/H) : 24 channels

- Conversion speed: 54 clocks (7.85 μ s@54 MHz)
- Start by an internal timer trigger
- Fixed channel/scan mode
- Single/repeat mode
- High-priority conversion mode
- Timer monitor function

(11) Watchdog timer : 1 channel

(12) Interrupt source

- CPU: 2 factors software interrupt instruction
- Internal: 50 factors..... The order of precedence can be set over 7 levels (except the watchdog timer interrupt).
- External: 20 factors..... The order of precedence can be set over 7 levels (except the NMI interrupt).
Because 8 factors are associated with KWUP, the number of interrupt factors is one.

(13) 209 pins Input/output ports

(14) Standby mode

- 4 standby modes (IDLE, SLEEP, STOP and BACKUP)

(15) Clock generator

- On-chip PLL (multiplication by 4)
- Clock gear function: The high-speed clock can be divided into 8/8, 7/8, 6/8, 5/8, 4/8, 2/8 or 1/8.
- Sub-clock: SLOW, SLEEP and BACKUP modes (32.768 kHz)

(16) Endian: Bi-endian (big-endian/little-endian)

(17) Maximum operating frequency

- 54 MHz (PLL multiplication)

(18) Operating voltage range

Core: 1.35 V to 1.65 V

I/O: 1.65 V to 3.3 V

ADC: 2.7 V to 3.3 V

Backup block : 2.3 V to 3.3 V (under normal operating conditions)
: 1.8 V to 3.3 V (in BACKUP mode)

(19) Package

- P-FBGA281 (13 mm × 13 mm, 0.65 mm pitch)

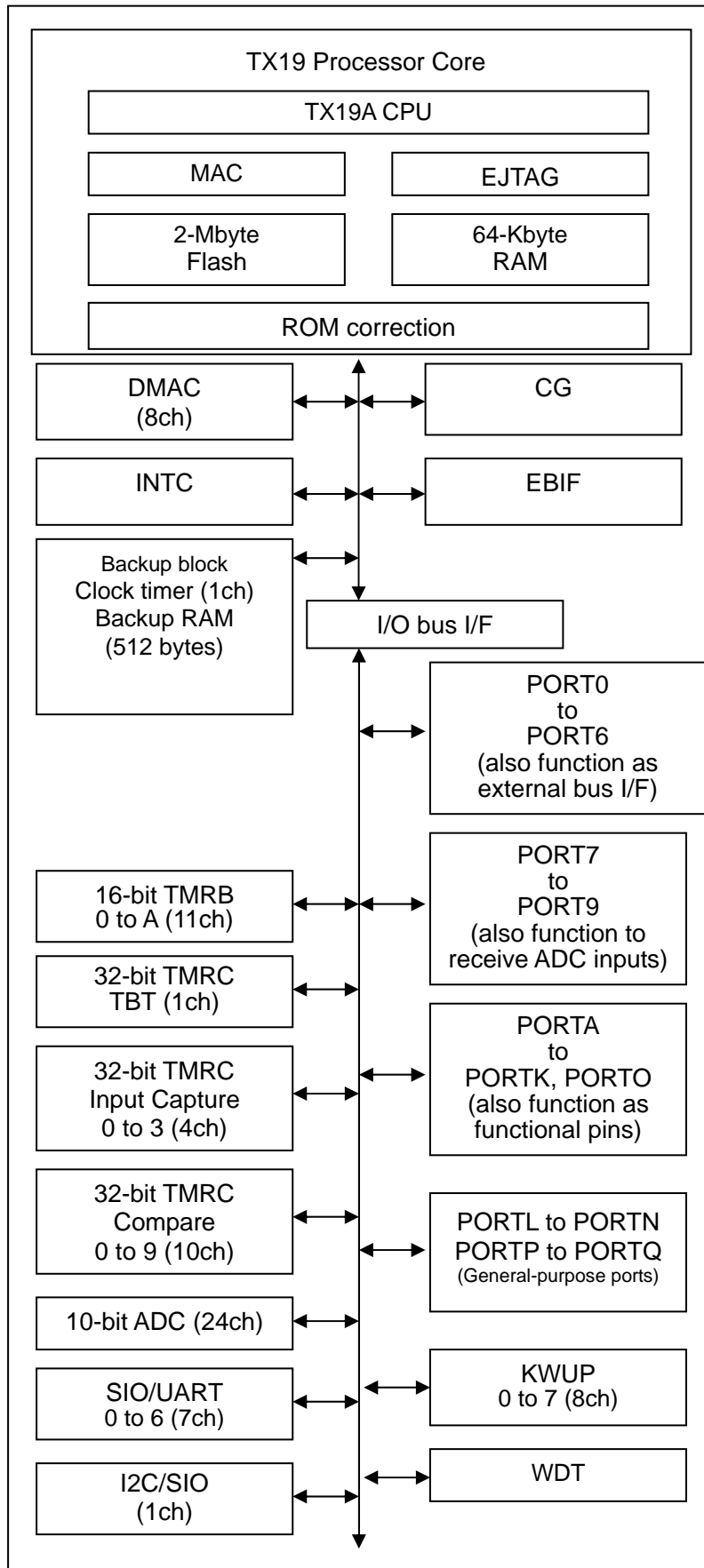

Fig. 1-1 TMP19A64F20AXBG Block Diagram

2. Pin Layout and Pin Functions

2.1 Pin Layout

Fig. 2.1.1 shows the pin layout of TMP19A64.

Fig. 2.1.1 Pin Layout Diagram (P-FBGA281)

A1	A2	A3	A4	A5	A6	A7	A8	A9	A10	A11	A12	A13	A14	A15	A16	A17	
B1	B2	B3	B4	B5	B6	B7	B8	B9	B10	B11	B12	B13	B14	B15	B16	B17	B18
C1	C2	C3	C4	C5	C6	C7	C8	C9	C10	C11	C12	C13	C14	C15	C16	C17	C18
D1	D2	D3	D4	D5	D6	D7	D8	D9	D10	D11	D12	D13	D14	D15	D16	D17	D18
E1	E2	E3	E4	E5	E6	E7	E8	E9	E10	E11	E12	E13	E14	E15	E16	E17	E18
F1	F2	F3	F4	F5		F7	F8	F9	F10	F11	F12		F14	F15	F16	F17	F18
G1	G2	G3	G4	G5	G6							G13	G14	G15	G16	G17	G18
H1	H2	H3	H4	H5	H6							H13	H14	H15	H16	H17	H18
J1	J2	J3	J4	J5	J6							J13	J14	J15	J16	J17	J18
K1	K2	K3	K4	K5	K6							K13	K14	K15	K16	K17	K18
L1	L2	L3	L4	L5	L6							L13	L14	L15	L16	L17	L18
M1	M2	M3	M4	M5	M6							M13	M14	M15	M16	M17	M18
N1	N2	N3	N4	N5		N7	N8	N9	N10	N11	N12		N14	N15	N16	N17	N18
P1	P2	P3	P4	P5	P6	P7	P8	P9	P10	P11	P12	P13	P14	P15	P16	P17	P18
R1	R2	R3	R4	R5	R6	R7	R8	R9	R10	R11	R12	R13	R14	R15	R16	R17	R18
T1	T2	T3	T4	T5	T6	T7	T8	T9	T10	T11	T12	T13	T14	T15	T16	T17	T18
U1	U2	U3	U4	U5	U6	U7	U8	U9	U10	U11	U12	U13	U14	U15	U16	U17	U18
	V2	V3	V4	V5	V6	V7	V8	V9	V10	V11	V12	V13	V14	V15	V16	V17	

Table 2.1.2 shows the pin numbers and names of TMP19A64.

Table 2.1.2 Pin Numbers and Names (1 of 2)

Pin No.	Pin name	Pin No.	Pin name	Pin No.	Pin name	Pin No.	Pin name	Pin No.	Pin name
A1	N.C.	A13	PN2	B8	P75/AN5	C2	PCST3 (EJTAG)	C14	PM7
A2	VREFL	A14	PN0	B9	PL0	C3	P92/AN18	C15	PM3
A3	P90/AN16	A15	PM5	B10	PL3	C4	P95/AN21	C16	PK3/KEY3
A4	P93/AN19	A16	PM1	B11	PO5/TXD6	C5	P82/AN10	C17	CVCC15
A5	P80/AN8	A17	X2	B12	PO1/INT1	C6	P85/AN13	C18	XT2
A6	P83/AN11	B1	AVCC31	B13	PN3	C7	P72/AN2	D1	TDO (EJTAG)
A7	P70/AN0	B2	VREFH	B14	PN1	C8	AVSS	D2	PCST2 (EJTAG)
A8	P74/AN4	B3	P91/AN17	B15	PM4	C9	PL1	D3	DINT (EJTAG)
A9	PO7/SCLK6/CTS6	B4	P94/AN20	B16	PM0	C10	PL4	D4	DVCC15
A10	PL2	B5	P81/AN9	B17	CVSS/BVSS	C11	PO4/INT4	D5	P96/AN22
A11	PO6/RXD6	B6	P84/AN12	B18	X1	C12	PN6	D6	P86/AN14
A12	PO0/INT0	B7	P71/AN1	C1	PCST0 (EJTAG)	C13	PN4	D7	P73/AN3

Table 2.1.1 Pin Numbers and Names (2 of 2)

Pin No.	Pin name	Pin No.	Pin name	Pin No.	Pin name	Pin No.	Pin name	Pin No.	Pin name
D8	DVCC15	F18	P46/SCOUT	K14	P11/INT1	N18	P14/D12/AD12/A12	T8	PD4/TXD4
D9	DVSS	G1	RESET	K15	P13/INT3	P1	PE4	T9	PC0/TXD0
D10	PL5	G2	TDI (EJTAG)	K16	P14/INT4	P2	PA2/TB0OUT	T10	PC3/TXD1
D11	PO3/INT3	G3	FVCC15	K17	DVCC30	P3	PA3/TB1IN0/INT7	T11	PH4/TCOUT8
D12	PN7	G4	DVSS	K18	P12/INT2	P4	PA4/TB1IN1/INT8	T12	PH6
D13	PN5	G5	TOVR/TSTA (EJTAG)	L1	FVCC3	P5	PA5/TB1OUT	T13	P53/A3
D14	PM2	G6	BW0	L2	PQ1/TPD1/TPC1 (EJTAG)	P6	PB6/TBAIN0	T14	P61/A9
D15	DVCC34	G13	PK7/KEY7	L3	PQ2/TPD2/TPC2 (EJTAG)	P7	PG2/TC2IN	T15	P21/A17/A1/A17
D16	PK2/KEY2	G14	BRESET	L4	PQ3/TPD3/TPC3 (EJTAG)	P8	PD6/SCLK4/CTS4	T16	P23/A19/A3/A19
D17	PK4/KEY4	G15	P41/CS1	L5	PE6/INTA	P9	PC2/SCLK0/CTS0	T17	P00/D0/AD0
D18	XT1	G16	P37/ALE	L6	PE7/INTB	P10	PC5/SCLK1/CTS1	T18	P01/D1/AD1
E1	DCLK (EJTAG)	G17	P35/BUSAK	L13	P13/D11/AD11/A11	P11	P52/A2	U1	PB4/TB8OUT
E2	PCST1 (EJTAG)	G18	FVCC15	L14	P17/D15/AD15/A15	P12	P62/A10	U2	PB3/TB7OUT
E3	TRST (EJTAG)	H1	NMI	L15	FVCC15	P13	P65/A13	U3	PB7/TBAIN1
E4	PCST4 (EJTAG)	H2	DVCC31	L16	PI0/INT0	P14	P26/A22/A6/A22	U4	PF1/SI/SCL
E5	ENDIAN	H3	PP7/TPD7 (EJTAG)	L17	P45/CS5	P15	P02/D2/AD2	U5	PF5/DREQ3
E6	P97/AN23	H4	BW1	L18	PJ3/DACK3	P16	P10/D8/AD8/A8	U6	PG1/TC1IN
E7	P87/AN15	H5	PLLOFF	M1	PQ0/TPD0/TPC0 (EJTAG)	P17	P12/D10/AD10/A10	U7	PD2/RXD3
E8	P76/AN6	H6	TCK (EJTAG)	M2	PQ7/TPD7/TPC7 (EJTAG)	P18	P11/D9/AD9/A9	U8	DVCC32
E9	P77/AN7	H13	TEST1	M3	PQ4/TPD4/TPC4 (EJTAG)	R1	PA0/TB0IN0/INT5	U9	PC7/RXD2
E10	PL6	H14	P31/WR	M4	PE3	R2	PA1/TB0IN1/INT6	U10	PH1/TCOUT5
E11	PL7	H15	P32/HWR	M5	PA7/TB3OUT	R3	PF3/DREQ2	U11	PH5/TCOUT9
E12	PM6	H16	P33/WAIT/RDY	M6	DVCC32	R4	PF4/DACK2	U12	P50/A0
E13	PK6/KEY6	H17	P30/RD	M13	P06/D6/AD6	R5	PF7/TBTIN	U13	P55/A5
E14	PK5/KEY5	H18	P40/CS0	M14	P07/D7/AD7	R6	PG7/TCOUT3	U14	DVCC33
E15	BVCC	J1	PP2/TPD2 (EJTAG)	M15	DVSS	R7	PG4/TCOUT0	U15	P64/A12
E16	PK1/KEY1	J2	PP3/TPD3 (EJTAG)	M16	PI0/DREQ2	R8	PD5/RXD4	U16	P20/A16/A0/A16
E17	PK0/KEY0	J3	PP4/TPD4 (EJTAG)	M17	PI2/DREQ3	R9	PC1/RXD0	U17	P24/A20/A4/A20
E18	DVCC15	J4	PP5/TPD5 (EJTAG)	M18	PI1/DACK2	R10	PC4/RXD1	U18	FVCC3
F1	DVSS	J5	PP6/TPD6 (EJTAG)	N1	PE5	R11	PH3/TCOUT7	V2	PB5/TB9OUT
F2	TMS (EJTAG)	J6	FVCC15	N2	PE0/TXD5	R12	P51/A1	V3	PG0/TC0IN
F3	EJE (EJTAG)	J13	DVSS	N3	PE2/SCLK5/CTS5	R13	P57/A7	V4	PF0/SO/SDA
F4	BUSMD	J14	P47	N4	PE1/RXD5	R14	P66/A14	V5	PG3/TC3IN
F5	BOOT	J15	N.C.	N5	PA6/TB2OUT	R15	P25/A21/A5/A21	V6	PG6/TCOUT2
F7	AVSS	J16	P44/CS4	N7	DVSS	R16	P03/D3/AD3	V7	PD1/TXD3
F8	AVSS	J17	P36/R/W	N8	PD7/INT9	R17	P04/D4/AD4	V8	PD0/SCLK2/CTS2
F9	AVCC32	J18	P34/BUSRQ	N9	DVCC15	R18	P05/D5/AD5	V9	PC6/TXD2
F10	DVCC34	K1	PP0/TPD0 (EJTAG)	N10	DVSS	T1	PB0/TB4OUT	V10	PH2/TCOUT6
F11	PO2/INT2	K2	PP1/TPD1 (EJTAG)	N11	P56/A6	T2	PB1/TB5OUT	V11	PH0/TCOUT4
F12	DVSS	K3	PQ5/TPD5/TPC5 (EJTAG)	N12	DVSS	T3	PB2/TB6OUT	V12	PH7
F14	BUPMD	K4	PQ6/TPD6/TPC6 (EJTAG)	N14	P27/A23/A7/A23	T4	PF2/SCK	V13	P54/A4
F15	P42/CS2	K5	DVSS	N15	P15/D13/AD13/A13	T5	PF6/DACK3	V14	P60/A8
F16	P43/CS3	K6	DVSS	N16	TEST3	T6	PG5/TCOUT1	V15	P63/A11
F17	DVCC33	K13	TEST2	N17	P16/D14/AD14/A14	T7	PD3/SCLK3/CTS3	V16	P67/A15
								V17	P22/A18/A2/A18

2.2 Pin Names and Functions

Table 2.2.1 shows the names and functions of input/output pins.

Table 2.2.1 Pin Names and Functions (1 of 6)

Pin name	Number of pins	Input or output	Function
P00-P07 D0-D7 AD0-AD7	8	Input/output Input/output Input/output	Port 0: Input/output port that allows input/output to be set in units of bits Data (lower): Data buses 0 to 7 (separate bus mode) Address data (lower): Address data buses 0 to 7 (multiplexed bus mode)
P10-P17 D8-D15 AD8-AD15 A8-A15	8	Input/output Input/output Input/output Output	Port 1: Input/output port that allows input/output to be set in units of bits Data (upper): Data buses 8 to 15 (separate bus mode) Address data (upper): Address data buses 8 to 15 (multiplexed bus mode) Address: Address buses 8 to 15 (multiplexed bus mode)
P20-P27 A16-A23 A0-A7 A16-A23	8	Input/output Output Output Output	Port 2: Input/output port that allows input/output to be set in units of bits Address: Address buses 16 to 23 (separate bus mode) Address: Address buses 0 to 7 (multiplexed bus mode) Address: Address buses 16 to 23 (multiplexed bus mode)
P30 RD	1	Output Output	Port 30: Port used exclusively for output Read: Strobe signal for reading external memory
P31 WR	1	Output Output	Port 31: Port used exclusively for output Write: Strobe signal for writing data of D0 to D7 pins
P32 HWR	1	Input/output Output	Port 32: Input/output port (with pull-up) Write upper-pin data: Strobe signal for writing data of D8 to D15 pins
P33 WAIT RDY	1	Input/output Input Input	Port 33: Input/output port (with pull-up) Wait: Pin for requesting CPU to put a bus in a wait state Ready: Pin for notifying CPU that a bus is ready
P34 BUSRQ	1	Input/output Input	Port 34: Input/output port (with pull-up) Bus request: Signal requesting CPU to allow an external master to take the bus control authority
P35 BUSAK	1	Input/output Output	Port 35: Input/output port (with pull-up) Bus acknowledge: Signal notifying that CPU has released the bus control authority in response to BUSRQ
P36 R/W	1	Input/output Output	Port 36: Input/output port (with pull-up) Read/write: "1" shows a read cycle or a dummy cycle. "0" shows a write cycle.
P37 ALE	1	Input/output Output	Port 37: Input/output port Address latch enable (address latch is enabled only if access to external memory is taking place)
P40 CS0	1	Input/output Output	Port 40: Input/output port (with pull-up) Chip select 0: "0" is output if the address is in a designated address area.
P41 CS1	1	Input/output Output	Port 41: Input/output port (with pull-up) Chip select 1: "0" is output if the address is in a designated address area.
P42 CS2	1	Input/output Output	Port 42: Input/output port (with pull-up) Chip select 2: "0" is output if the address is in a designated address area.
P43 CS3	1	Input/output Output	Port 43: Input/output port (with pull-up) Chip select 3: "0" is output if the address is in a designated address area.
P44 CS4	1	Input/output Output	Port 44: Input/output port (with pull-up) Chip select 4: "0" is output if the address is in a designated address area.
P45 CS5	1	Input/output Output	Port 45: Input/output port (with pull-up) Chip select 5: "0" is output if the address is in a designated address area.
P46 SCOUT	1	Input/output Output	Port 46: Input/output port System clock output: Selectable between high- and low-speed clock outputs, as in the case of CPU
P47	1	Input/output	Port 47: Input/output port
P50-P57 A0-A7	8	Input/output Output	Port 5: Input/output port that allows input/output to be set in units of bits Address: Address buses 0 to 7 (separate bus mode)
P60-P67 A8-A15	8	Input/output Output	Port 6: Input/output port that allows input/output to be set in units of bits Address: Address buses 8 to 15 (separate bus mode)

Table 2.2.1 Pin Names and Functions (2 of 6)

Pin name	Number of pins	Input or output	Function
P70-P77 AN0-AN7	8	Input Input	Port 7: Port used exclusively for input Analog input: Input from A/D converter
P80-P87 AN8-AN15	8	Input Input	Port 8: Port used exclusively for input Analog input: Input from A/D converter
P90-P97 AN16-AN23	8	Input Input	Port 9: Port used exclusively for input Analog input: Input from A/D converter
PA0 TB0IN0 INT5	1	Input/output Input Input	Port A0: Input/output port 16-bit timer 0 input 0: For inputting the count/capture trigger of a 16-bit timer 0 Interrupt request pin 5: Selectable between "H" level, "L" level, rising edge, and falling edge Input pin with Schmitt trigger
PA1 TB0IN1 INT6	1	Input/output Input Input	Port A1: Input/output port 16-bit timer 0 input 1: For inputting the count/capture trigger of a 16-bit timer 0 Interrupt request pin 6: Selectable "H" level, "L" level, rising edge and falling edge Input pin with Schmitt trigger
PA2 TB0OUT	1	Input/output Output	Port A2: Input/output port 16-bit timer 0 output: 16-bit timer 0 output pin
PA3 TB1IN0 INT7	1	Input/output Input Input	Port A3: Input/output port 16-bit timer 1 input 0: For inputting the count/capture trigger of a 16-bit timer 1 Interrupt request pin 7: Selectable between "H" level, "L" level, rising edge and falling edge Input pin with Schmitt trigger
PA4 TB1IN1 INT8	1	Input/output Input Input	Port A4: Input/output port 16-bit timer 1 input 1: For inputting the count/capture trigger of a 16-bit timer 1 Interrupt request pin 8: Selectable between "H" level, "L" level, rising edge and falling edge Input pin with Schmitt trigger
PA5 TB1OUT	1	Input/output Output	Port A5: Input/output port 16-bit timer 1 output: 16-bit timer 1 output pin
PA6 TB2OUT	1	Input/output Output	Port A6: Input/output port 16-bit timer 2 output: 16-bit timer 2 output pin
PA7 TB3OUT	1	Input/output Output	Port A7: Input/output port 16-bit timer 3 output: 16-bit timer 3 output pin
PB0 TB4OUT	1	Input/output Output	Port B0: Input/output port 16-bit timer 4 output: 16-bit timer 4 output pin
PB1 TB5OUT	1	Input/output Output	Port B1: Input/output port 16-bit timer 5 output: 16-bit timer 5 output pin
PB2 TB6OUT	1	Input/output Output	Port B2: Input/output port 16-bit timer 6 output: 16-bit timer 6 output pin
PB3 TB7OUT	1	Input/output Output	Port B3: Input/output port 16-bit timer 7 output: 16-bit timer 7 output pin
PB4 TB8OUT	1	Input/output Output	Port B4: Input/output port 16-bit timer 8 output: 16-bit timer 8 output pin
PB5 TB9OUT	1	Input/output Output	Port B5: Input/output port 16-bit timer 9 output: 16-bit timer 9 output pin
PB6 TBAIN0	1	Input/output Input	Port B6: Input/output port 16-bit timer A input 0: for inputting the count/capture trigger of a 16-bit timer A 2-phase pulse counter input 0
PB7 TBAIN1	1	Input/output Input	Port B7: Input/output port 16-bit timer A input 1: For inputting the count/capture trigger of a 16-bit timer A 2-phase pulse counter input 1

Table 2.2.1 Pin Names and Functions (3 of 6)

Pin name	Number of pins	Input or output	Function
PC0 TXD0	1	Input/output Output	Port C0: Input/output port Sending serial data 0: Open drain output pin depending on the program used
PC1 RXD0	1	Input/output Input	Port C1: Input/output port Receiving serial data 0
PC2 SCLK0 CTS0	1	Input/output Input/output Input	Port C2: Input/output port Serial clock input/output 0 Ready to send serial data 0 (Clear To Send): Open drain output pin depending on the program used
PC3 TXD1	1	Input/output Output	Port C3: Input/output port Sending serial data 1: Open drain output pin depending on the program used
PC4 RXD1	1	Input/output Input	Port C4: Input/output port Receiving serial data 1
PC5 SCLK1 CTS1	1	Input/output Input/output Input	Port C5: Input/output port Serial clock input/output 1 Ready to send serial data 1 (Clear To Send): Open drain output pin depending on the program used
PC6 TXD2	1	Input/output Output	Port C6: Input/output port Sending serial data 2: Open drain output pin depending on the program used
PC7 RXD2	1	Input/output Input	Port C7: Input/output port Receiving serial data 2
PD0 SCLK2 CTS2	1	Input/output Input/output Input	Port D0: Input/output port Serial clock input/output 2 Ready to send serial data 2 (Clear To Send): Open drain output pin depending on the program used
PD1 TXD3	1	Input/output Output	Port D1: Input/output port Sending serial data 3: Open drain output pin depending on the program used
PD2 RXD3	1	Input/output Input	Port D2: Input/output port Receiving serial data 3
PD3 SCLK3 CTS3	1	Input/output Input/output Input	Port D3: Input/output port Serial clock input/output 3 Ready to send serial data 3 (Clear To Send): Open drain output pin depending on the program used
PD4 TXD4	1	Input/output Output	Port D4: Input/output port Sending serial data 4: Open drain output pin depending on the program used
PD5 RXD4	1	Input/output Input	Port D5: Input/output port Receiving serial data 4
PD6 SCLK4 CTS4	1	Input/output Input/output Input	Port D6: Input/output port Serial clock input/output 4 Ready to send serial data 4 (Clear To Send): Open drain output pin depending on the program used
PD7 INT9	1	Input/output Input	Port D7: Input/output port Interrupt request pin 9: Selectable between "H" level, "L" level, rising edge and falling edge Input pin with Schmitt trigger

Table 2.2.1 Pin Names and Functions (4 of 6)

Pin name	Number of pins	Input or output	Function
PE0 TXD5	1	Input/output Output	Port E0: Input/output port Sending serial data 5: Open drain output pin depending on the program used
PE1 RXD5	1	Input/output Input	Port E1: Input/output port Receiving serial data 5
PE2 SCLK5 CTS5	1	Input/output Input/output Input	Port E2: Input/output port Serial clock input/output 5 Ready to send serial data 5 (Clear To Send): Open drain output pin depending on the program used
PE3-PE5	3	Input/output	Ports E3 to E5: Input/output ports that allow input/output to be set in units of bits
PE6 INTA	1	Input/output Input	Port E6: Input/output port Interrupt request pin A: Selectable between "H" level, "L" level, rising edge, and falling edge Input pin with Schmitt trigger
PE7 INTB	1	Input/output Input	Port E7: Input/output port Interrupt request pin B: Selectable between "H" level, "L" level, rising edge, and falling edge Input pin with Schmitt trigger
PF0 SO SDA	1	Input/output Output Input/output	Port F0: Input/output port Pin for sending data if the serial bus interface operates in the SIO mode Pin for sending and receiving data if the serial bus interface operates in the I ² C mode Open drain output pin depending on the program used. Input with Schmitt trigger
PF1 SI SCL	1	Input/output Input Input/output	Port F1: Input/output port Pin for receiving data if the serial bus interface operates in the SIO mode Pin for inputting and outputting a clock if the serial bus interface operates in the I ² C mode Open drain output pin depending on the program used Input with Schmitt trigger
PF2 SCK	1	Input/output Input/output	Port F2: Input/output port Pin for inputting and outputting a clock if the serial bus interface operates in the SIO mode
PF3 DREQ2	1	Input/output Input	Port F3: Input/output port DMA request signal 2: For inputting the request to transfer data by DMA from an external I/O device to DMAC2
PF4 DACK2	1	Input/output Output	Port F4: Input/output port DMA acknowledge signal 2: Signal showing that DREQ2 has acknowledged a DMA transfer request
PF5 DREQ3	1	Input/output Input	Port F5: Input/output port DMA request signal 3: For inputting the request to transfer data by DMA from an external I/O device to DMAC3
PF6 DACK3	1	Input/output Output	Port F6: Input/output port DMA acknowledge signal 3: Signal showing that DREQ3 has acknowledged a DMA transfer request
PF7 TBTIN	1	Input/output Input	Port F7: Input/output port 32-bit time base timer input: For inputting the count for 32-bit time base timer
PG0-PG3 TC0IN-TC3IN	4	Input/output Input	Ports G0 to G3: Input/output ports that allow input/output to be set in units of bits For inputting the capture trigger for 32-bit timer
PG4-PG7 TCOU0-TCOUT3	4	Input/output Output	Ports G4 to G7: Input/output ports that allow input/output to be set in units of bits Outputting 32-bit timer if the result of a comparison is a match
PH0-PH5 TCOU4-TCOUT9	6	Input/output Output	Ports H0 to H5: Input/output ports that allow input/output to be set in units of bits Outputting 32-bit timer if the result of a comparison is a match
PH6-PH7	2	Input/output	Ports H6 to H7: Input/output ports that allow input/output to be set in units of bits
PI0 INT0	1	Input/output Input	Port I0: Input/output port Interrupt request pin 0: Selectable between "H" level, "L" level, rising edge and falling edge Input pin with Schmitt trigger
PI1 INT1	1	Input/output Input	Port I1: Input/output port Interrupt request pin 1: Selectable between "H" level, "L" level, rising edge and falling edge Input pin with Schmitt trigger
PI2 INT2	1	Input/output Input	Port I2: Input/output port Interrupt request pin 2: Selectable between "H" level, "L" level, rising edge and falling edge Input pin with Schmitt trigger

Table 2.2.1 Pin Names and Functions (5 of 6)

Pin name	Number of pins	Input or output	Function
PI3 INT3	1	Input/output Input	Port I3: Input/output port Interrupt request pin 3: Selectable between "H" level, "L" level, rising edge and falling edge Input pin with Schmitt trigger
PI4 INT4	1	Input/output Input	Port I4: Input/output port Interrupt request pin 4: Selectable between "H" level, "L" level, rising edge and falling edge Input pin with Schmitt trigger
PJ0 DREQ2	1	Input/output Input	Port J0: Input/output port DMA request signal 2: For inputting the request to transfer data by DMA from an external I/O device to DMAC2
PJ1 DACK2	1	Input/output Output	Port J1: Input/output port DMA acknowledge signal 2: Signal showing that DREQ2 has acknowledged a DMA transfer request
PJ2 DREQ3	1	Input/output Input	Port J2: Input/output port DMA request signal 3: For inputting the request to transfer data by DMA from an external I/O device to DMAC3
PJ3 DACK3	1	Input/output Output	Port J3: Input/output port DMA acknowledge signal 3: Signal showing that DREQ3 has acknowledged a DMA transfer request
PK0-PK7 KEY0-KEY7	8	Input/output Input	Port K: Input/output port that allows input/output to be set in units of bits KEY on wake up input 0 to 7 (with pull-up) With Schmitt trigger
PL0-PL7	8	Input/output	Port L: Input/output port that allows input/output to be set in units of bits
PM0-PM7	8	Input/output	Port M: Input/output port that allows input/output to be set in units of bits
PN0-PN7	8	Input/output	Port N: Input/output port that allows input/output to be set in units of bits
PO0 INT0	1	Input/output Input	Port O0: Input/output port Interrupt request pin 0: Selectable between "H" level, "L" level, rising edge and falling edge Input pin with Schmitt trigger
PO1 INT1	1	Input/output Input	Port O1: Input/output port Interrupt request pin 1: Selectable between "H" level, "L" level, rising edge and falling edge Input pin with Schmitt trigger
PO2 INT2	1	Input/output Input	Port O2: Input/output port Interrupt request pin 2: Selectable between "H" level, "L" level, rising edge and falling edge Input pin with Schmitt trigger
PO3 INT3	1	Input/output Input	Port O3: Input/output port Interrupt request pin 3: Selectable between "H" level, "L" level, rising edge and falling edge Input pin with Schmitt trigger
PO4 INT4	1	Input/output Input	Port O4: Input/output port Interrupt request pin 4: Selectable between "H" level, "L" level, rising edge and falling edge Input pin with Schmitt trigger
PO5 TXD6	1	Input/output Output	Port O5: Input/output port Sending serial data 6: Open drain output pin depending on the program used
PO6 RXD6	1	Input/output Input	Port O6: Input/output port Receiving serial data 6
PO7 SCLK6 CTS6	1	Input/output Input/output Input	Port O7: Input/output port Serial clock input/output 6 Ready to send serial data 6 (Clear To Send): Open drain output pin depending on the program used
PP0-PP7 TPD0-TPD7	8	Input/output Output	Port P: Input/output port that allows input/output to be set in units of bits Outputting trace data from the data access address: Signal for DSU-ICE
PQ0-PQ7 TPC0-TPC7 TPD0-TPD7	8	Input/output Output Output	Port P: Input/output port that allows input/output to be set in units of bits Outputting trace data from the program counter: Signal for DSU-ICE Outputting trace data from the data access address: Signal for DSU-ICE

Table 2.2.1 Pin Names and Functions (6 of 6)

Pin name	Number of pins	Input or output	Function
DCLK	1	Output	Debug clock: Signal for DSU-ICE
EJE	1	Input	EJTAG enable: Signal for DSU-ICE (input with Schmitt trigger and built-in noise filter)
PCST4-0	5	Output	PC trace status: Signal for DSU-ICE
DINT	1	Input	Debug interrupt: Signal for DSU-ICE (input with Schmitt trigger, pull-up and built-in noise filter)
TOVR/TSTA	1	Output	Outputting the status of PD data overflow status: Signal for DSU-ICE
TCK	1	Input	Test clock input: Signal for testing JTAG (input with Schmitt trigger and pull-up)
TMS	1	Input	Test mode select input: Signal for testing JTAG (input with Schmitt trigger and pull-up)
TDI	1	Input	Test data input: Signal for testing JTAG (input with Schmitt trigger and pull-up)
TDO	1	Output	Test data output: Signal for testing JTAG
TRST	1	Input	Test reset input: Signal for testing JTAG (input with Schmitt trigger and pull-down)
NMI	1	Input	Nonmaskable interrupt request pin: Pin for requesting an interrupt at the falling edge Input with Schmitt trigger and built-in noise filter
PLLOFF	1	Input	Fix this pin to the "H (DVCC15) level."(Input with Schmitt trigger)
RESET	1	Input	Reset: Initializing LSI (with pull-up) Input with Schmitt trigger and built-in noise filter
X1/X2	2	Input/output	Pin for connecting to a high-speed oscillator
XT1/XT2	2	Input/output	Pin for connecting to a low-speed oscillator
BUPMD	1	Input	Backup mode trigger pin: This pin must be set to "L level" in backup mode.
BRESET	1	Input	Backup module reset: Initializing the backup module (with pull-up) Input with Schmitt trigger
BUSMD	1	Input	Pin for setting an external bus mode: This pin functions as a multiplexed bus by sampling the "H (DVCC15) level" upon the rising of a reset signal. It also functions as a separate bus by sampling "L" upon the rising of a reset signal. When performing a reset operation, pull it up or down according to a bus mode to be used.
ENDIAN	1	Input	Pin for setting endian: This pin is used to set a mode. It performs a big-endian operation by sampling the "H (DVCC15) level" upon the rising of a reset signal, and performs a little-endian operation by sampling "L" upon the rising of a reset signal. When performing a reset operation, pull it up or down according to the type of endian to be used.
BOOT	1	Input	Pin for setting a single boot mode: This pin goes into single boot mode by sampling "L" upon the rising of a reset signal. It is used to overwrite internal flash memory. By sampling "H (DVCC15) level" upon the rising of a reset signal, it performs a normal operation. This pin should be pulled up under normal operating conditions. Pull it up when resetting.
BW0-1	2	Input	Fix these pins to BW0="H (DVCC15)" and BW1="H (DVCC15)," respectively. (Input with Schmitt trigger)
VREFH	1	Input	Pin (H) for supplying the A/D converter with a reference power supply Connect this pin to AVCC31 if the A/D converter is not used.
VREFL	1	Input	Pin (L) for supplying the A/D converter with a reference power supply Connect this pin to AVSS if the A/D converter is not used.
AVCC31-32	2	–	Pin for supplying the A/D converter with a power supply. Connect it to a power supply even if the A/D converter is not used.
AVSS	3	–	A/D converter GND pin (0 V). Connect this pin to GND even if the A/D converter is not used.
TEST1-3	3	Input	TEST pin: To be fixed to GND.
CVCC15	1	–	Pin for supplying oscillators with power: 1.5 V power supply
CVSS/BVSS	1	–	GND pin (0 V) for oscillators and backup modules
DVCC15	4	–	Power supply pin: 1.5 V power supply
BVCC	1	–	Pin exclusively for supplying backup modules with power: 3 V power supply
DVCC30-34	8	–	Power supply pin: 3 V power supply
DVSS	11	–	GND pin (0 V)
FVCC15	4	–	Power supply pin: 1.5 V power supply
FVCC3	2	–	Power supply pin: 3 V power supply

Note 1: For $\overline{\text{BUSMD}}$, $\overline{\text{ENDIAN}}$ and $\overline{\text{BOOT}}$ pins, the state designated for each pin ("H" or "L" level) must be maintained during one system clock before and after the rising of a reset signal. The reset pin must always be in a stable state at both "L" and "H" levels.

Note 2: For $\overline{\text{DREQ2}}$, $\overline{\text{DACK2}}$, $\overline{\text{DREQ3}}$ and $\overline{\text{DACK3}}$, it is necessary to go to the port function register and to select one port from two groups of ports, PF3 to PF6 and PJ0 to PJ3. Two ports cannot be operated simultaneously to use the same function. Likewise, for pins INT0 through INT4, one port must be selected from ports PI0 to PI4 and ports PO0 to PO4.

Table 2.2.2 shows the pin names and power supply pins.

Table 2.2.2 Pin names and power supply pins

Pin name	Power supply pin	Pin name	Power supply pin
P0	DVCC33	PCST4 to 0	DVCC31
P1	DVCC33	DCLK	DVCC31
P2	DVCC33	$\overline{\text{EJE}}$	DVCC31
P3	DVCC33	$\overline{\text{TRST}}$	DVCC31
P4	DVCC33	TDI	DVCC31
P5	DVCC33	TDO	DVCC31
P6	DVCC33	TMS	DVCC31
P7	AVCC32	TCK	DVCC31
P8	AVCC32	$\overline{\text{DINT}}$	DVCC31
P9	AVCC31	TOV	DVCC31
PA	DVCC32	$\overline{\text{BUSMD}}$	DVCC15
PB	DVCC32	$\overline{\text{BOOT}}$	DVCC15
PC	DVCC32	$\overline{\text{ENDIAN}}$	DVCC15
PD	DVCC32	$\overline{\text{NMI}}$	DVCC15
PE	DVCC32	$\overline{\text{BRESET}}$	BVCC
PF	DVCC32	$\overline{\text{BUPMD}}$	BVCC
PG	DVCC32	X1, X2	CVCC15
PH	DVCC32	XT1, XT2	BVCC
PI	DVCC30	BW0 and 1	DVCC15
PJ	DVCC33	$\overline{\text{PLLOFF}}$	DVCC15
PK	DVCC34	$\overline{\text{RESET}}$	DVCC15
PL	DVCC34		
PM	DVCC34		
PN	DVCC34		
PO	DVCC34		
PP	DVCC31		
PQ	DVCC31		

- $2.7\text{ V} \leq \text{AVCC32} \leq \text{AVCC31}$

Table 2.2.3 shows the pin numbers and power supply pins.

Table 2.2.3 Pin numbers and power supply pins

Power supply pin	Pin number	Voltage range
DVCC15	D4, D8, E18, N9	1.35 V to 1.65 V
CVCC15	C17	1.35 V to 1.65 V
DVCC30	K17	1.65 V to 3.3 V
DVCC31	H2	1.65 V to 3.3 V
DVCC32	M6, U8	1.65 V to 3.3 V
DVCC33	F17, U14	1.65 V to 3.3 V
DVCC34	D15, F10	1.65 V to 3.3 V
AVCC31	B1	2.7 V to 3.6 V
AVCC32	F9	2.7 V to 3.6 V
FVCC15	G3, G18, J6, L15	1.35 V to 1.65 V
FVCC3	L1, U18	2.7 V to 3.6 V
BVCC	E15	<u>2.3 V to 3.3 V</u> (under normal operating conditions) 1.8 V to 3.3 V (in BACKUP mode)

3. Flash Memory Operation

This section describes the hardware configuration and operation of the flash memory. The feature of this device is that the internal ROM of TMP19A64C1DXBG is replaced by an internal flash memory. Other configurations and functions of the device remain the same as with TMP19A64C1DXBG. Please refer to the TMP19A64C1DXBG data sheet for functions not described in this section.

3.1 Flash Memory

3.1.1 Features

1) Memory capacity

The TMP19A64F20AXBG device contains two 8M bits (1MB) of flash memory capacity. The memory area consists of 4 independent memory blocks (128 kB × 16) to enable independent write access to each block. When the CPU is to access the internal flash memory, 32-bit data bus width is used.

2) Write/erase

Write unit: 1 page (128 words) × 4k
 Erase unit: Selectable from 128 KB, 512 KB, and 1 MB
 Protection unit: Selectable in 512 KB blocks
 Protection erasure unit: Selectable in 1 MB blocks

3) Write/erase time

Write time: 8 sec/2 chip (Typ) 2 msec/128 word (Typ.)
 Erase time: 1.6 sec /2 chip (Typ) 100 msec/128 Kbyte (Typ.)
 Protection bit erase time: 100 msec/2 bit (Typ)

(Note) The above values are theoretical values not including data transfer time.
 The write time per chip depends on the write method to be used by the user.

4) Programming method

Two modes are available, i.e., the onboard programming mode to allow programming on the user's board and the writer mode to program the device using an EPROM writer.

- Onboard programming mode
 - 1) User boot mode
The user's original rewriting method can be supported.
 - 2) Single boot mode
The rewriting method to use serial data transfer (Toshiba's unique method) can be supported.
- Writer mode
Use of a general purpose EPROM writer is supported.

5) Rewriting method

The flash memory included in this device is generally compliant with the applicable JEDEC standards except for some specific functions. Therefore, if the user is currently using an external flash memory device, it is easy to implement the functions into this device. Furthermore, the user is not required to build his/her own programs to realize complicated write and erase functions because such functions are automatically performed using the circuits already built-in the flash memory chip.

This device is also implemented with a read-security function to inhibit reading flash memory data from any external writer device. On the other hand, rewrite protection is available only through command-based software programming; any hardware setting method to apply +12VDC is not supported. The above described security function is automatically enabled when all the four area are configured for protection. When the user removes protection, the internal data is automatically erased before the protection is actually removed.

JEDEC compliant functions	Modified, added, or deleted functions
<ul style="list-style-type: none"> • Automatic programming • Automatic chip erase • Automatic block erase • Data polling/toggle bit 	<p><Modified> Block protect (only software protection is supported)</p> <p><Deleted> Erase resume - suspend function</p> <p>Automatic multiple block erase (supported to the chip level)</p>

3.1.2 Block Diagram

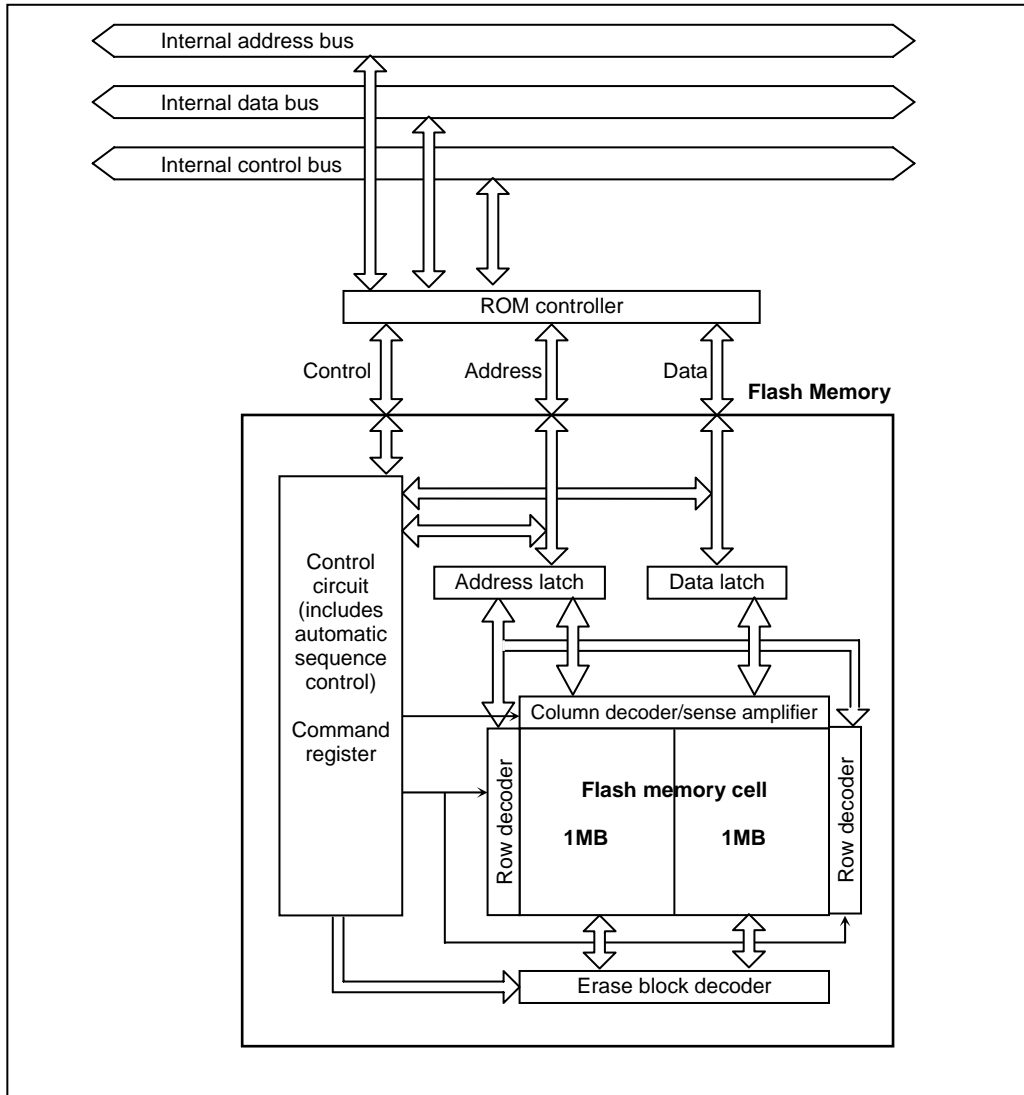

Fig. 3.1.2.1 Block Diagram of the Flash Memory Section

3.2 Operation Mode

This device has four operation modes including the mode not to use the internal flash memory.

Table 3.2.1.1 Operation Modes

Operation mode	Operation details
Single chip mode	After reset is cleared, it starts up from the internal flash memory.
Normal mode	<p>In this operation mode, two different modes, i.e., the mode to execute user application programs and the mode to rewrite the flash memory onboard the user's card, are defined. The former is referred to as "normal mode" and the latter "user boot mode."</p> <p>The user can uniquely configure the system to switch between these two modes. For example, the user can freely design the system such that the normal mode is selected when the port "00" is set to "1" and the user boot mode is selected when it is set to "0."</p> <p>The user should prepare a routine as part of the application program to make the decision on the selection of the modes.</p>
User boot mode	
Single boot mode	After reset is cleared, it starts up from the internal Boot ROM (Mask ROM). In the Boot ROM, an algorithm to enable flash memory rewriting on the user's set through the serial port of this device is programmed. By connecting to an external host computer through the serial port, the internal flash memory can be programmed by transferring data in accordance with predefined protocols.
Writer mode	This mode allows use of a general purpose EPROM writer to rewrite the internal flash memory. Please use a special program adaptor and an EPROM writer that are recommended for use.

Among the flash memory operation modes listed in the above table, the user boot mode, single boot mode, and writer mode are programmable modes. These two modes, the User Boot mode and the Single Boot mode, are referred to as "Onboard Programming" modes where onboard rewriting of internal flash memory can be made on the user's card.

Either the single chip, single boot, or writer operation mode can be selected by externally setting the levels of the BW0, BW1, and $\overline{\text{BOOT}}$ input pins while the device is in the reset state.

Except for the case of the writer mode, the CPU starts operation in the selected operation mode when the reset condition is removed after the pin levels are set. The writer mode is used with $\overline{\text{RESET}}$ set to "0". Be sure not to change the levels during operation once the mode is selected. The mode setting method and the mode transition diagram are shown below:

Table 3.2.1.2 Operation Mode Setting

	Operation mode	Input pin			
		$\overline{\text{RESET}}$	BW0	BW1	$\overline{\text{BOOT}}$
(1)	Single chip mode	0 → 1	1	1	1
(2)	Single boot mode	0 → 1	1	1	0
(3)	Writer mode	*1	*1	*1	*1

*1: Don't care (No explanation is given in this section regarding condition settings.)

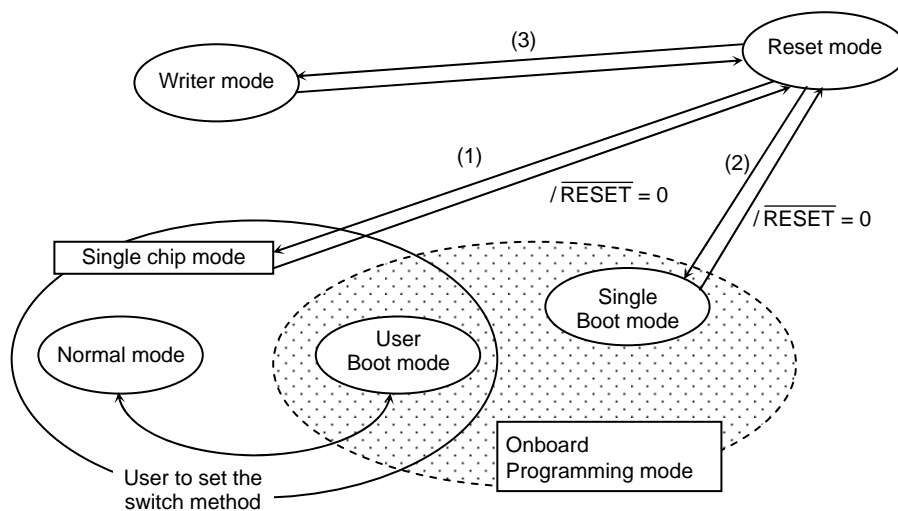

The number in the parentheses indicate the mode number in the above table to show the input pin setting to be made for the corresponding state transition.

Fig. 3.2.1.3 Mode Transition Diagram

3.2.1 Reset Operation

To reset the device, ensure that the power supply voltage is within the operating voltage range, that the internal oscillator has been stabilized, and that the $\overline{\text{RESET}}$ input is held at "0" for a minimum duration of 12 system clocks (1.8 μs with 54 MHz operation; the "1/8" clock gear mode is applied after reset).

- (Note 1) Regarding power-on reset of devices with internal flash memory;**
 For devices with internal flash memory, it is necessary to apply "0" to the $\overline{\text{RESET}}$ inputs upon power on for a minimum duration of 60 microseconds regardless of the operating frequency.
 During this period, each protection bit, to be described later, is locked in the state it is written regardless of the state it ought to be. The original values of protection bits can be checked by reading the register FLCS <BLPRO 3:0> after the power on reset operation is normally terminated.
- (Note 2) While flash programming is in progress, at least 0.5 microseconds of reset period is required regardless of the system clock frequency.**

3.2.2 DSU (EJTAG) - PROBE Interface

This interface is used when the DSU probe is used in debugging. This is the dedicated interface for connection to the DSU probe. Please refer to the operation manual for the DSU probe you are going to use for details of debugging procedures to use the DSU probe. Here, the function to enable/disable the DSU probe in the DSU (EJTAG) mode is described.

1) Security function

This device allows use of an on-board DSU probe for debugging. To facilitate this, the device is implemented with a security measure to prevent easy reading of the internal flash memory by a third party other than the authorized user. By enabling the security function, it becomes impossible to read the internal flash memory from a DSU probe. Use this function together with the security function of the internal flash memory itself as described later.

2) DSU probe enable/disable function

This device allows use of on-board DSU probes for debugging operations. To facilitate this, the device is implemented with the "DSU probe inhibit" function (hereafter referred to as the "**DSU inhibit function**") to prevent easy reading of the internal flash memory by a third party other than the authorized user. By enabling the DSU inhibit function, use of any DSU probe becomes impossible.

3) DSU enable (Enables use of DSU probes for debugging)

In order to prevent the DSU inhibit function from being accidentally removed by system runaway, etc., the method to cancel the inhibit function requires a double action operation so it is necessary to set DSU security mode register DSUSEC1<DSUOFF> to "0" and also write the security code "0x0000_00C5" to the DSU security control register DSUSEC2 to cancel the function. Then, debugging to use a DSU probe is allowed. While power to the device is still applied, setting DSUSEC1<DSUOFF> to "1" and writing "0x0000_00C5" to the DSUSEC2 register will enable the security function again.

Table 3.2.2.1 DSU Security Mode Register

DSUSEC1 (0xFFFF_E510)		7	6	5	4	3	2	1	0	
	Bit Symbol	/								DSUOFF
	Read/Write	R								R/W
	After power on reset	0								1
	Function	Always reads "0."								1: DSU disable 0: DSU available
		15	14	13	12	11	10	9	8	
Bit Symbol	/									
Read/Write	R									
After power on reset	0									
Function	Always reads "0."									
		23	22	21	20	19	18	17	16	
Bit Symbol	/									
Read/Write	R									
After power on reset	0									
Function	Always reads "0."									
		31	30	29	28	27	26	25	24	
Bit Symbol	/									
Read/Write	R									
After power on reset	0									
Function	Always reads "0."									

(Note) This register can be initialized only by a power on reset. Normal reset inputs cannot reset the register.

(Note) This register must be 32-bit accessed.

Table 3.2.2.2 DSU Security Control Register

DSUSEC2 (0xFFFF_E514)	Bit Symbol	DSECODE07	DSECODE06	DSECODE05	DSECODE04	DSECODE03	DSECODE02	DSECODE01	DSECODE00
	Read/Write	W							
	After reset	0							
	Function	Write "0x0000_00C5."							
		15	14	13	12	11	10	9	8
Bit Symbol	DSECODE15	DSECODE14	DSECODE13	DSECODE12	DSECODE11	DSECODE10	DSECODE09	DSECODE08	
Read/Write	W								
After reset	0								
Function	Write "0x0000_00C5."								
		23	22	21	20	19	18	17	16
Bit Symbol	DSECODE23	DSECODE22	DSECODE21	DSECODE20	DSECODE19	DSECODE18	DSECODE17	DSECODE16	
Read/Write	W								
After reset	0								
Function	Write "0x0000_00C5."								
		31	30	29	28	27	26	25	24
Bit Symbol	DSECODE31	DSECODE30	DSECODE29	DSECODE28	DSECODE27	DSECODE26	DSECODE25	DSECODE24	
Read/Write	W								
After reset	0								
Function	Write "0x0000_00C5."								

(Note) This register must be 32-bit accessed.

4) Example use by the user

An example to use a DSU probe together with this function is shown as follows:

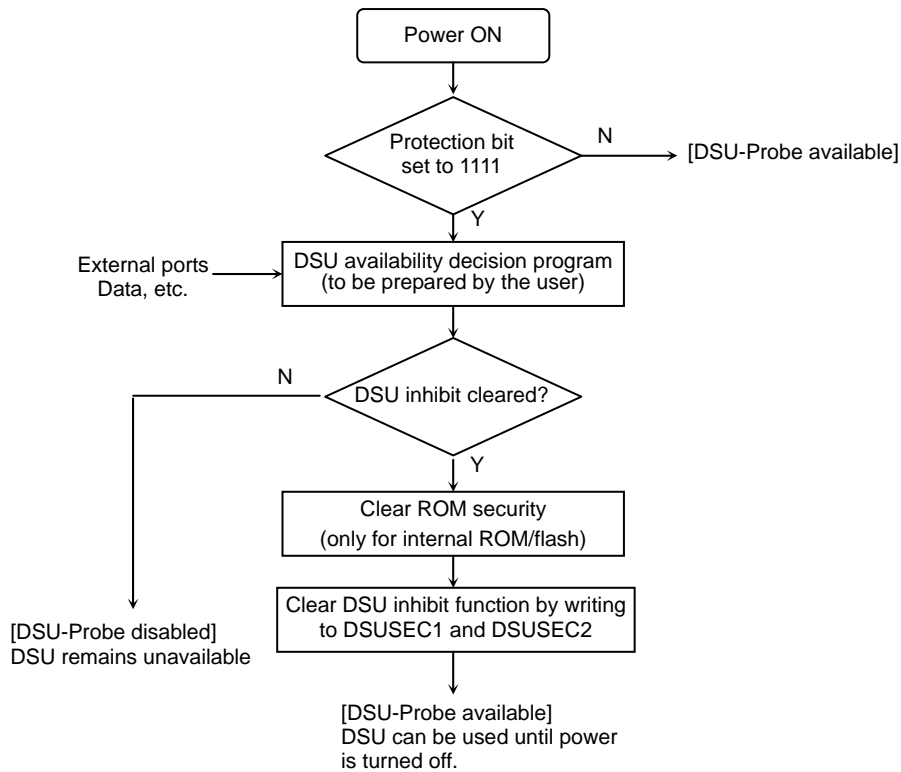

Fig. 3.2.2.3 Example Use of DSU Inhibit Function

3.3 On-board Programming of Flash Memory (Rewrite/Erase)

In on-board programming, the CPU is to execute software commands for rewriting or erasing the flash memory. The rewrite/erase control program should be prepared by the user beforehand. Because the flash memory content cannot be read while it is being written or erased, it is necessary to run the rewrite/erase program from the internal RAM or from an external memory device after shifting to the user boot mode. In this section, flash memory addresses are represented in virtual addresses unless otherwise noted.

3.4 Flash Memory

Except for some functions, writing and erasing flash memory data are in accordance with the standard JEDEC commands. In writing or erasing, use the SW command of the CPU to enter commands to the flash memory. Once the command is entered, the actual write or erase operation is automatically performed internally.

Table 3.4.1.1 Flash Memory Functions

Major functions	Description
Automatic page program	Writes data automatically (in 128 word blocks).
Automatic chip erase	Automatically erases the flash memory area one chip at a time (1 MB at a time).
Automatic block erase	Erases a selected block automatically (128 kB at a time).
Write protect	The write or erase function can be individually inhibited for each area (of 512 kB). When all areas are set for protection, the security function is automatically enabled.
Security function	A security function is implemented to inhibit reading from the flash memory when the device is in the writer mode. By setting protection to all the four areas, the security function is enabled. In order to disable the security function, it is necessary to cancel write protection when the entire flash memory is automatically erased.

Note that addressing of operation commands is different from the case of standard commands due to the specific interface arrangements with the CPU as detailed operation of the user boot mode and RAM transfer mode is described later. Also note that the flash memory is written in 32-bit blocks. So, 32-bit (word) data transfer commands must be used in writing the flash memory.

(1) Block configuration

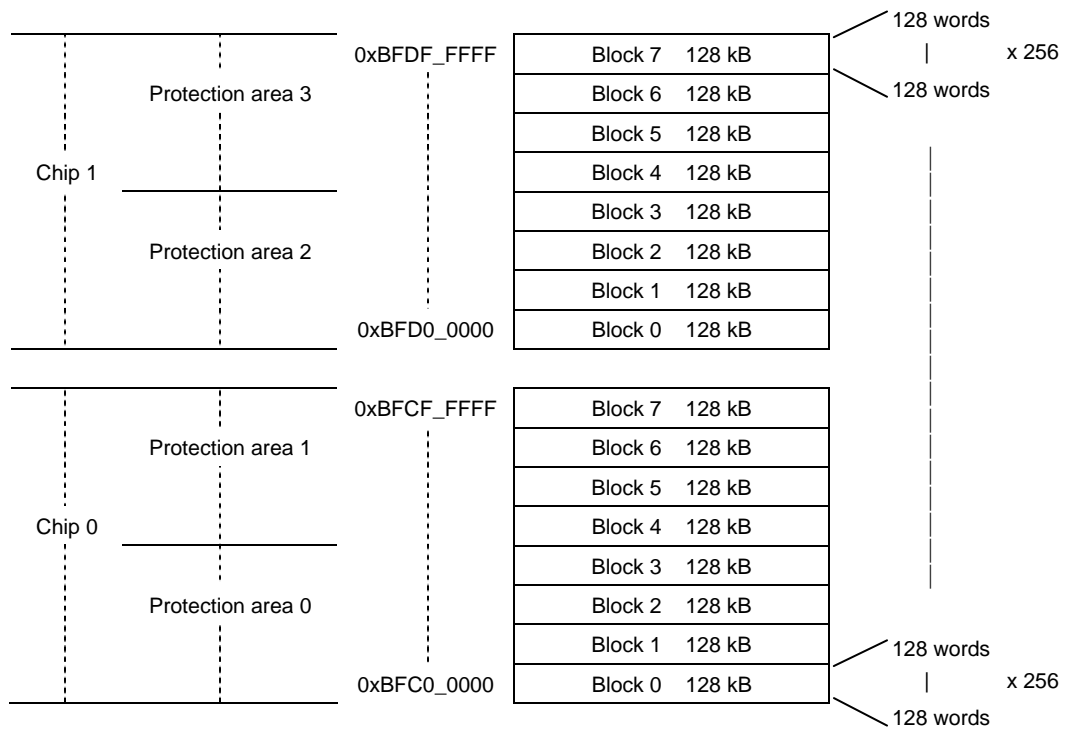

Fig. 3.4.1.2 Block Configuration of Flash Memory

(2) Basic operation

Generally speaking, this flash memory device has the following two operation modes:

- The mode to read memory data (Read mode)
- The mode to automatically erase or rewrite memory data (Automatic operation)

Transition to the automatic mode is made by executing a command sequence while it is in the memory read mode. In the automatic operation mode, flash memory data cannot be read and any commands stored in the flash memory cannot be executed. During automatic operation, be sure not to cause any exceptions other than debug exceptions and reset while a DSU probe is connected. Any interrupt or exception generation cannot set the device to the read mode except when a hardware reset is generated.

1) Read

When data is to be read, the flash memory must be set to the read mode. The flash memory will be set to the read mode immediately after power is applied, when CPU reset is removed, or when an automatic operation is normally terminated. In order to return to the read mode from other modes or after an automatic operation has been abnormally terminated, either the Read/reset command (a software command to be described later) or a hardware reset is used. The device must also be in the read mode when any command written on the flash memory is to be executed.

- Read/reset command and Read command (software reset)

When an automatic operation is abnormally terminated, the flash memory cannot return to the read mode by itself (When $FLCS<RDY/BSY> = 0$, data read from the flash memory is undefined.) In this case, the Read/reset command can be used to return the flash memory to the read mode. Also, when a command that has not been completely written has to be canceled, the Read/reset command must be used to return to the read mode. The Read command is used to return to the read mode after executing the SW command to write the data "0x0000_00F0" to two arbitrary addresses 0x001x_xxxx and 0x000x_xxxx of the flash memory.

- With the Read/reset command, the device is returned to the read mode after completing the third bus write cycle.

2) Command write

This flash memory uses the command control method. Commands are executed by executing a command sequence to the flash memory. The flash memory executes automatic operation commands according to the address and data combinations applied (refer to Command Sequence). If it is desired to cancel a command write operation already in progress or when any incorrect command sequence has been entered, the Read/reset command is to be executed. Then, the flash memory will terminate the command execution and return to the read mode.

Also, when issuing a command, the address [20:19] must be fixed to either "1" or "0" in order to enable a decision to select either chip 0 or 1.

While commands are generally comprised of several bus cycles, the operation to apply the SW command to the flash memory is called "bus write cycle." The bus write cycles are to be in a specific sequential order and the flash memory will perform an automatic operation when the sequence of the bus write cycle data and address of a command write operation is in accordance with a predefined specific sequence. If any bus write cycle does not follow a predefined command write sequence, the flash memory will terminate the command execution and return to the read mode. The address [31:21] in each bus write cycle should be the virtual address [31:21] of command execution. It will be explained later for the address bits [20:8].

- (Note 1) Command sequences are executed from outside the flash memory area.
- (Note 2) The interval between bus write cycles for this device must be 15 system clock cycles or longer. The command sequencer in the flash memory device requires a certain time period to recognize a bus write cycle. If more than one bus write cycles are executed within this time period, normal operation cannot be expected. For adjusting the applicable bus write cycle interval using a software timer to be operated at the operating frequency, use the section [10](#) "[ID-Read](#)" to check for the appropriateness.
- (Note 3) Between the bus write cycles, never use any load command (such as LW, LH, or LB) to the flash memory or perform a DMA transmission by specifying the flash area as the source address. Also, don't execute a Jump command to the flash memory. While a command sequence is being executed, don't generate any interrupt such as maskable interrupts (except debug exceptions when a DSU probe is connected).
- If such an operation is made, it can result in an unexpected read access to the flash memory and the command sequencer may not be able to correctly recognize the command. While it could cause an abnormal termination of the command sequence, it is also possible that the written command is incorrectly recognized.
- (Note 4) The SYNC command must be executed immediately after the SW command for each bus write cycle.
- (Note 5) For the command sequencer to recognize a command, the device must be in the read mode prior to executing the command. Be sure to check before the first bus write cycle that the FLCS[0] RDY/BSY bit is set to "1." It is recommended to subsequently execute a Read command.
- (Note 6) Upon issuing a command, if any address or data is incorrectly written, be sure to perform a system reset operation or issue a reset command (for Chip 0 and Chip 1) to return to the read mode again.

3) Reset

Hardware reset

The flash memory has a reset input as the memory block and it is connected to the CPU reset signal. Therefore, when the RESET input pin of this device is set to V_{IL} or when the CPU is reset due to any overflow of the watch dog timer, the flash memory will return to the read mode terminating any automatic operation that may be in progress. The CPU reset is also used in returning to the read mode when an automatic operation is abnormally terminated or when any mode set by a command is to be canceled. It should also be noted that applying a hardware reset during an automatic operation can result in incorrect rewriting of data. In such a case, be sure to perform the rewriting again.

Refer to Section 3.1 "Reset Operation" for CPU reset operations. After a given reset input, the CPU will read the reset vector data from the flash memory and starts operation after the reset is removed.

4) Automatic Page Programming

Writing to a flash memory device is to make "1" data cells to "0" data cells. Any "0" data cell cannot be changed to a "1" data cell. For making "0" data cells to "1" data cells, it is necessary to perform an erase operation.

The automatic page programming function of this device writes data in 128 word blocks. A 128 word block is defined by a same [31:9] address and it starts from the address [8:0] = 0 and ends at the address [8:0] = 0x1FF. This programming unit is hereafter referred to as a "page."

Writing to data cells is automatically performed by an internal sequencer and no external control by the CPU is required. The state of automatic page programming (whether it is in writing operation or not) can be checked by the FLCS <RDY/BSY> register.

Also, any new command sequence is not accepted while it is in the automatic page programming mode. If it is desired to interrupt the automatic page programming, use the hardware reset function. If the operation is stopped by a hardware reset operation, it is necessary to once erase the page and then perform the automatic page programming again because writing to the page has not been normally terminated.

The automatic page programming operation is allowed only once for a page already erased. No programming can be performed twice or more times irrespective of the data cell value whether it is "1" or "0." Note that rewriting to a page that has been once written requires execution of the automatic block erase or automatic chip erase command before executing the automatic page programming command again. Note that an attempt to rewrite a page two or more times without erasing the content can cause damages to the device.

No automatic verify operation is performed internally to the device. So, be sure to read the data programmed to confirm that it has been correctly written.

The automatic page programming operation starts when the fourth bus write cycle of the command cycle is completed. On and after the fifth bus write cycle, data will be written sequentially starting from the next address of the address specified in the fourth bus write cycle (in the fourth bus write cycle, the page top address will be command written) (32 bits of data is input at a time). Be sure to use the SW command in writing commands on and after the fourth bus cycle. In this, any SW command shall not be placed across word boundary. On and after the fifth bus write cycle, data is command written to the same page area. Even if it is desired to write the page only partially, it is required to perform the automatic page programming for the entire page. In this case, the address input for the fourth bus write cycle shall be set to the top address of the page. Be sure to perform command write operation with the input data set to "1" for the data cells not to be set to "0." For example, if the top address of a page is not to be written, set the input data of the fourth bus write cycle to 0xFFFFFFFF to command write the data.

Once the fourth bus cycle is executed, it is in the automatic programming operation. This condition can be checked by monitoring the register bit FLCS <RDY/BSY>. Any new command sequence is not accepted while it is in automatic page programming mode. If it is desired to stop operation, use the hardware reset function. Be careful in doing so because data cannot be written normally if the operation is interrupted. When a single page has been command written normally terminating the automatic page writing process, the FLCS <RDY/BSY> bit is set to "1" and it returns to the read mode.

When multiple pages are to be written, it is necessary to execute the page programming command for each page because the number of pages to be written by a single execution of the automatic page program command is limited to only one page. It is not allowed for automatic page programming to process input data across pages.

Data cannot be written to a protected block. When automatic programming is finished, it automatically returns to the read mode. This condition can be checked by monitoring FLCS <RDY/BSY>. If automatic programming has failed, the flash memory is locked in the mode and will not return to the read mode. For returning to the read mode, it is necessary to use the reset command or hardware reset to reset the flash memory or the device. In this case, while writing to the address has failed, it is recommended not to use the device or not to use the block that includes the failed address.

Note: Software reset becomes ineffective in bus write cycles on and after the fourth bus write cycle of the automatic page programming command.

5) Automatic chip erase (1MB at a time)

The automatic chip erase operation starts when the sixth bus write cycle of the command cycle is completed.

This condition can be checked by monitoring FLCS <RDY/BSY>. While no automatic verify operation is performed internally to the device, be sure to read the data to confirm that data has been correctly erased. Any new command sequence is not accepted while it is in an automatic chip erase operation. If it is desired to stop operation, use the hardware reset function. If the operation is forced to stop, it is necessary to perform the automatic chip erase operation again because the data erasing operation has not been normally terminated.

Also, any protected blocks cannot be erased. If all the blocks are protected, the automatic chip erase operation will not be performed and it returns to the read mode after completing the sixth bus read cycle of the command sequence. When an automatic chip erase operation is normally terminated, it automatically returns to the read mode. If an automatic chip erase operation has failed, the flash memory is locked in the mode and will not return to the read mode.

For returning to the read mode, it is necessary to use the reset command or hardware reset to reset the flash memory or the device. In this case, the failed block cannot be detected. It is recommended not to use the device anymore or to identify the failed block by using the block erase function for not to use the identified block anymore.

6) Automatic block erase (128 kB at a time)

The automatic block erase operation starts when the sixth bus write cycle of the command cycle is completed.

This status of the automatic block erase operation can be checked by monitoring FLCS <RDY/BSY>. While no automatic verify operation is performed internally to the device, be sure to read the data to confirm that data has been correctly erased. Any new command sequence is not accepted while it is in an automatic block erase operation. If it is desired to stop operation, use the hardware reset function. In this case, it is necessary to perform the automatic block erase operation again because the data erasing operation has not been normally terminated.

Note that any block in the protected area is not erased. It returns to the read mode upon completing the last bus cycle of the command sequence. If an automatic block erase operation has failed, the flash memory is locked in the mode and will not return to the read mode. In this case, use the reset command or hardware reset to reset the flash memory or the device.

Note: Commands can be accepted only by Chip 0. Even if automatic protection bit programming or erasure is commanded to Chip 1, it will not result in any setting or clearing of the protection.

7) Automatic programming of protection bits (for each 512 kB block)

This device is implemented with four protection bits. The protection bits can be individually set in the automatic programming. The applicable protection bit is specified in the seventh bus write cycle. By automatically programming the protection bits, write and/or erase functions can be inhibited individually for each protection area. The protection status of each area can be checked by FLCS <PROTECT3:0> to be described later. Any new command sequence is not accepted while automatic programming is in progress to program the protection bits. If it is desired to stop the programming operation, use the hardware reset function. In this case, it is necessary to perform the programming operation again because the protection bits may not have been correctly programmed. If all the protection bits have been programmed, the flash memory cannot be read

from any area outside the flash memory such as the internal RAM. In this condition, the FLCS <PROTECT3:0> register is set to "0xF" (secure state). After this, no command writing can be performed.

Note: Commands can be accepted only by Chip 0. Even if automatic protection bit programming or erasure is commanded to Chip 1, it will not result in any setting or clearing of the protection.

Note: Software reset is ineffective in the seventh bus write cycle of the automatic protection bit programming command. The FLCS <RDY/BSY> bit turns to "0" after entering the seventh bus write cycle.

8) Automatic erasing of protection bits

Different results will be obtained when the automatic protection bit erase command is executed depending on the status of the protection bits. It depends on the status of FLCS<PROTECT3:0> before the command execution whether it is set to "0 x F" or to any other values. Be sure to check the value of FLCS<PROTECT3:0> before executing the automatic protection bit erase command.

- When FLCS<PROTECT3:0> is set to "0 x F" (all the protection bits are programmed):

When the automatic protection bit erase command is command written, the flash memory is automatically initialized within the device. When the seventh bus write cycle is completed, the entire area of the flash memory data cells is erased and then all the protection bits are erased. This operation can be checked by monitoring FLCS <RDY/BSY>. If the automatic operation to erase protection bits is normally terminated, FLCS<PROTECT3:0> will be set to "0x0." While no automatic verify operation is performed internally to the device, be sure to read the data to confirm that it has been correctly erased. For returning to the read mode while the automatic operation after the seventh bus cycle is in progress, it is necessary to use the hardware reset to reset the flash memory or the device. If this is done, it is necessary to check the status of protection bits by FLCS<PROTECT3:0> after retuning to the read mode and perform either the automatic protection bit erase, automatic chip erase, or automatic block erase operation, as appropriate.

- When FLCS<PROTECT3:0> is other than "0 x F" (not all the protection bits are programmed):

The protection condition can be canceled by the automatic protection bit erase operation. With this device, protection bits can be erased handling two bits at a time. The target bits are specified in the seventh bus write cycle and when the command is completed, the device is in a condition the two bits are erased. The protection status of each block can be checked by FLCS<PROTECT3:0> to be described later. This status of the programming operation for automatic protection bits can be checked by monitoring FLCS <RDY/BSY>. When the automatic operation to erase protection bits is normally terminated, the two protection bits of FLCS<PROTECT3:0> selected for erasure are set to "0."

In any case, any new command sequence is not accepted while it is in an automatic operation to erase option bits. If it is desired to stop the operation, use the hardware reset function. When the automatic operation to erase option bits is normally terminated, it returns to the read mode.

9) Flash control/ status register

This register is used to monitor the status of the flash memory and to indicate the block protection status.

Table 3.4.1.3 Flash Control Register

FLCS (0xFFFF_E520)	Bit Symbol	PROTECT3	PROTECT2	PROTECT1	PROTECT0		ROMTYPE	PRGB	RDY/BSY
	Read/Write	R				R	R	R/W	R
	After power on reset	0	0	0	0	0	0	0	1
	Function	Protection area setting (for each 512 kB) 0000: No blocks are protected xxx1: Block 0 is protected xx1x: Block 1 is protected x1xx: Block 2 is protected 1xxx: Block 3 is protected					ROM ID bit 0:Flash 1:MROM	Programming bit 0: Already issued 1: Issue	Ready/Busy 0: In operation 1: Operation terminated
		7	6	5	4	3	2	1	0
Bit Symbol									
Read/Write	R								
After power on reset	0	0	0	0	0	0	0	0	
Function									
	15	14	13	12	11	10	9	8	
Bit Symbol									
Read/Write	R								
After power on reset	0	0	0	0	0	0	0	0	
Function									
	23	22	21	20	19	18	17	16	
Bit Symbol									
Read/Write	R								
After power on reset	0	0	0	0	0	0	0	0	
Function									
	31	30	29	28	27	26	25	24	
Bit Symbol									
Read/Write	R								
After power on reset	0	0	0	0	0	0	0	0	
Function									

Bit 0: Ready/Busy flag bit

The RDY/BSY output is provided as a means to monitor the status of automatic operation. This bit is a function bit for the CPU to monitor the function. When the flash memory is in automatic operation, it outputs "0" to indicate that it is busy. When the automatic operation is terminated, it returns to the ready state and outputs "1" to accept the next command. If the automatic operation has failed, this bit maintains the "0" output. Returns to "1" upon power on.

(Note) Be sure to confirm the ready status whenever a command is to be issued. Issuing a command while the device is busy may result in a situation where further command inputs are rejected in addition to the fact that the command cannot be transferred correctly. In such a case, restore the system by using system reset or a reset command.

Bit 1: Programming bit

This bit notifies the flash interface that a command is to be issued to the flash memory.

Be sure to set this bit to "1" whenever a command is to be issued to the internal flash memory. Also, when all commands have been issued, set this bit to "0" after confirming that the <RDY/BSY> bit is set to "1."

Bit 2: ROM type identification bit

This bit is read after reset to identify whether the ROM is a flash ROM or a mask ROM.

Flash ROM: "0"

Mask ROM: "1"

Bits [7:4]: Protection bits (x: can be set to any combination of areas)

Each of the protection bits (4 bits) represents the protection status of the corresponding area. When a bit is set to "1," it indicates that the area corresponding to the bit is protected. When the area is protected, data cannot be written into it.

10) ID-Read

Using the ID-Read command, you can obtain the type and other information on the flash memory contained in the device. The data to be loaded will be different depending on the write address to the flash [15:14] of the fourth and subsequent bus write cycles (any input data other than 0xF0 can be used). On and after the fourth bus write cycle, when an LW command (to read an arbitrary flash memory area) is executed after an SW command, the ID value will be loaded (execute a SYNC command immediately after the LW command). Once the fourth bus write cycle of an ID-Read command has passed, the device will not automatically return to the read mode. In this condition, the set of the fourth bus write cycle and LW/SYNC commands can be repetitively executed. For returning to the read mode, reset the system or use the Read or Read/reset command.

The ID-Read command can be used when it is necessary for an application to identify whether the device in the product has an internal flash memory or an internal ROM. This is effective because a mask ROM doesn't have a command sequencer so it interprets any ID-Read command written as simply a pair of SW and LW commands applied to the mask ROM. If an ID-Read command is to be executed on a device with an internal mask ROM, it is necessary to select an address at which the return value to a normal LW command is different from the ID-Read execution result (ID) from a device with an internal flash memory, also taking into account any applicable security conditions.

Note: Setting is required when a command is to be issued to Chip 0 or Chip 1. Refer to (4) List of Command Sequences.

(4) List of Command Sequences

This product is implemented with two 1 MB flash ROM chips (1 MB x 2). It is necessary to identify the target chip (0 or 1) before executing a command. This identification is made by the address bit [20].

Table 3.4.1.2 Flash Memory Access from the Internal CPU

Flash Chip 0 Command Sequence: Addr. [20] = 0

Command sequence	First bus cycle	Second bus cycle	Third bus cycle	Fourth bus cycle	Fifth bus cycle	Sixth bus cycle	Seventh bus cycle
	Addr.	Addr.	Addr.	Addr.	Addr.	Addr.	Addr.
	Data	Data	Data	Data	Data	Data	Data
Read	0xXX	RA					
	0xF0	RD					
Read/reset	0x55XX	0xAAXX	0x55XX	RA			
	0xAA	0x55	0xF0	RD			
ID-Read	0x55XX	0xAAXX	0x55XX	IA	0xXX	-	
	0xAA	0x55	0x90	0x00	ID	-	
Automatic page programming (note)	0x55XX	0xAAXX	0x55XX	PA	PA	PA	PA
	0xAA	0x55	0xA0	PD0	PD1	PD2	PD3
Automatic chip erase	0x55XX	0xAAXX	0x55XX	0x55XX	0xAAXX	0x55XX	-
	0xAA	0x55	0x80	0xAA	0x55	0x10	-
Auto Block erase (note)	0x55XX	0xAAXX	0x55XX	0x55XX	0xAAXX	BA	-
	0xAA	0x55	0x80	0xAA	0x55	0x30	-
Protection bit programming	0x55XX	0xAAXX	0x55XX	0x55XX	0xAAXX	0x55XX	PBA
	0xAA	0x55	0x9A	0xAA	0x55	0x9A	0x9A
Protection bit erase	0x55XX	0xAAXX	0x55XX	0x55XX	0xAAXX	0x55XX	PBA
	0xAA	0x55	0x6A	0xAA	0x55	0x6A	0x6A

Flash Chip 1 Command Sequence: Addr. [20] = 1

Command sequence	First bus cycle	Second bus cycle	Third bus cycle	Fourth bus cycle	Fifth bus cycle	Sixth bus cycle	Seventh bus cycle
	Addr.	Addr.	Addr.	Addr.	Addr.	Addr.	Addr.
	Data	Data	Data	Data	Data	Data	Data
Read	0xXX	RA					
	0xF0	RD					
Read/reset	0x55XX	0xAAXX	0x55XX	RA			
	0xAA	0x55	0xF0	RD			
ID-Read	0x55XX	0xAAXX	0x55XX	IA	0xXX	-	
	0xAA	0x55	0x90	0x00	ID	-	
Automatic page programming (note)	0x55XX	0xAAXX	0x55XX	PA	PA	PA	PA
	0xAA	0x55	0xA0	PD0	PD1	PD2	PD3
Automatic chip erase	0x55XX	0xAAXX	0x55XX	0x55XX	0xAAXX	0x55XX	-
	0xAA	0x55	0x80	0xAA	0x55	0x10	-
Auto Block erase (note)	0x55XX	0xAAXX	0x55XX	0x55XX	0xAAXX	BA	-
	0xAA	0x55	0x80	0xAA	0x55	0x30	-

- RA: Read address **RD: Read data**
- IA: ID address **ID: ID data**
- PA: Program page address (specified in Addr.[20:9])
- PD: Program data (32-bit data)

After the fourth bus cycle, enter data in the order of the address for a page.

- BA: Block address PBA: Protection bit address

- (Note) To select the target memory access area (block), set either "0" or "1" to the address bits [20:19] in the first bus cycle.
- (Note 1) Always set "0" to the address bits [1:0] in the entire bus cycle. (Setting values to bits [7:2] are undefined.)
- (Note 2) Bus cycles are "bus write cycles" except for the second bus cycle of the Read command, the fourth bus cycle of the Read/reset command, and the fifth bus cycle of the ID-Read command. Bus write cycles are executed by SW commands. Use "Data" in the table for the rt register [7:0] of SW commands. The address [31:16] in each bus write cycle should be the target flash memory address [31:16] of the command sequence. Use "Addr." in the table for the address [15:0].
- (Note 3) In executing the bus write cycles, the interval between each bus write cycle shall be 15 system clocks or more.
- (Note 4) The "Sync command" must be executed immediately after completing each bus write cycle.
- (Note 5) Execute the "Sync command" immediately following the "LW command" after the fourth bus write cycle of the ID-Read command.

(5) Address bit configuration for bus write cycles

Table 3.4.1.3 Address Bit Configuration for Bus Write Cycles

Address	Addr [31:21]	Addr [20]	Addr [19]	Addr [18:17]	Addr [16]	Addr [15]	Addr [14]	Addr [13]	Addr [12:9]	Addr [8]	Addr [7:0]
Normal commands	Normal bus write cycle address configuration										
	Flash area	Chip selection	Area selection	"0" is recommended			Command			Addr [1:0]=0 (fixed), Others: 0 (recommended)	
Block erase	BA: Block address (Set the sixth bus write cycle address for block erase operation)										
	Flash area	Chip selection	Area selection	Block selection	Addr[1:0]=0 (fixed), Others: 0 (recommended)						
Auto page programming	PA: Program page address (Set the fourth bus write cycle address for page programming operation)										
	Flash area	Chip selection	Area selection	Block selection	Page selection				Addr[1:0]=0 (fixed), Others: 0 (recommended)		
ID-READ	IA: ID address (Set the fourth bus write cycle address for ID-Read operation)										
	Flash area	Chip selection	"0" is recommended			ID address		Addr[1:0]=0 (fixed), Others: 0 (recommended)			
Protection bit programming	PBA: Protection bit address (Set the seventh bus write cycle address for protection bit programming)										
	Flash area	Fixed to "0"	"0" is recommended			Protection bit write 00: Area 0 01: Area 1 10: Area 2 11: Area 3		Addr[1:0]=0 (fixed), Others: 0 (recommended)			
Protection bit erase	PBA: Protection bit address (Set the seventh bus write cycle address for protection bit erasure)										
	Flash area	Fixed to "0"	"0" is recommended			Erase protection for 0: Area 0, 1 1: Area 2, 3		Addr[1:0]=0 (fixed), Others: 0 (recommended)			

- (Note) Table 3.4.1.2 "Flash Memory Access from the Internal CPU" can also be used.
- (Note) Address setting can be performed according to the "Normal bus write cycle address configuration" from the first bus cycle.
- (Note) "'0" is recommended" can be changed as necessary.

Table 3.4.1.4 Block Erase Address Table

Select Area			Set Address[20:17]				Address Area		Size
Chip	Area	BA	[20]	[19]	[18]	[17]	Flash Memory Address	When applied to the projected area	
Chip 1	Area 3	Block 7	1	1	1	1	0xBFDE_0000-0xBFDF_FFFF	0x001E_0000-0x001F_FFFF	128 KB
		Block 6	1	1	1	0	0xBFDC_0000-0xBFDD_FFFF	0x001C_0000-0x001D_FFFF	128 KB
		Block 5	1	1	0	1	0xBFDA_0000-0xBFDB_FFFF	0x001A_0000-0x001B_FFFF	128 KB
	Area 2	Block 4	1	1	0	0	0xBF8_0000-0xBF9_FFFF	0x0018_0000-0x0019_FFFF	128 KB
		Block 3	1	0	1	1	0xBF6_0000-0xBF7_FFFF	0x0016_0000-0x0017_FFFF	128 KB
		Block 2	1	0	1	0	0xBF4_0000-0xBF5_FFFF	0x0014_0000-0x0015_FFFF	128 KB
		Block 1	1	0	0	1	0xBF2_0000-0xBF3_FFFF	0x0012_0000-0x0013_FFFF	128 KB
Block 0	1	0	0	0	0xBF0_0000-0xBF1_FFFF	0x0010_0000-0x0011_FFFF	128 KB		
Chip 0	Area 1	Block 7	0	1	1	1	0xBFCE_0000-0xBFCE_FFFF	0x000E_0000-0x000F_FFFF	128 KB
		Block 6	0	1	1	0	0xBFCC_0000-0xBFCD_FFFF	0x000C_0000-0x000D_FFFF	128 KB
		Block 5	0	1	0	1	0xBFCA_0000-0xBFCE_FFFF	0x000A_0000-0x000B_FFFF	128 KB
	Area 0	Block 4	0	1	0	0	0xBF8_0000-0xBF9_FFFF	0x0008_0000-0x0009_FFFF	128 KB
		Block 3	0	0	1	1	0xBF6_0000-0xBF7_FFFF	0x0006_0000-0x0007_FFFF	128 KB
		Block 2	0	0	1	0	0xBF4_0000-0xBF5_FFFF	0x0004_0000-0x0005_FFFF	128 KB
		Block 1	0	0	0	1	0xBF2_0000-0xBF3_FFFF	0x0002_0000-0x0003_FFFF	128 KB
Block 0	0	0	0	0	0xBF0_0000-0xBF1_FFFF	0x0000_0000-0x0001_FFFF	128 KB		

Table 3.4.1.5 Protection Bit Programming Address Table

PBA	The seventh bus write cycle address [15:14]	
	Address [15]	Address [14]
Area 0	0	0
Area 1	0	1
Area 2	1	0
Area 3	1	1

Table 3.4.1.6 Protection Bit Erase Address Table

PBA	The seventh bus write cycle address [15:14]	
	Address [15]	Address [14]
Area 0	0	X
Area 1	0	X
Area 2	1	X
Area 3	1	X

The protection bit erase command will erase bits 0 and 1 together.

The bits 2 and 3 are also erased together.

Table 3.4.1.7 The ID-Read command's fourth bus write cycle ID address (IA) and the data to be read by the following LW command (ID)

IA [15:14]	ID [7: 0]	Code
00b	0x98	Manufacturer code
01b	0x5A	Device code
11b	0x06	Macro code
10b	Reserved	---

4. Electrical Characteristics

The letter x in equations presented in this chapter represents the cycle period of the fsys clock selected through the programming of the SYSCR1.SYSCK bit. The fsys clock may be derived from either the high-speed or low-speed crystal oscillator. The programming of the clock gear function also affects the fsys frequency. All relevant values in this chapter are calculated with the high-speed (fc) system clock (SYSCR1.SYSCK = 0) and a clock gear factor of 1/fc (SYSCR1.GEAR[2:0] = 000).

4.1 Maximum Ratings

Parameter		Symbol	Rating	Unit
Supply voltage		V _{CC2} (Core)	- 0.3 to 3.0	V
		V _{CC3} (I/O)	- 0.3 to 3.9	
		AV _{CC} (A/D)	- 0.3 to 3.9	
		BV _{CC}	- 0.3 to 3.9	
Supply voltage		V _{IN}	- 0.3 to V _{CC} +0.3	V
Low-level output current	Per pin	I _{OL}	5	mA
	Total	ΣI _{OL}	50	
High-level output current	Per pin	I _{OH}	-5	
	Total	ΣI _{OH}	50	
Power dissipation (Ta = 85°C)		PD	600	mW
Soldering temperature (10 s)		T _{SOLDER}	260	°C
Storage temperature		T _{STG}	-40 to 125	°C
Operating temperature	Except during flash W/E	T _{OPR}	-20 to 85	°C
	During flash W/E		0 to 70	
Write/erase cycles		N _{EW}	100	cycle

V_{CC15}=DV_{CC15}=CV_{CC15}=FV_{CC15}、V_{CC3}=DV_{CC3n} (n=0 to 4)、AV_{CC}=AV_{CC3m} (m=1 to 2) V_{SS}=DV_{SS} * =AV_{SS} * =CV_{SS}=FV_{SS}

Note: Maximum ratings are limiting values of operating and environmental conditions which should not be exceeded under the worst possible conditions. The equipment manufacturer should design so that no maximum rating value is exceeded with respect to current, voltage, power dissipation, temperature, etc. Exposure to conditions beyond those listed above may cause permanent damage to the device or affect device reliability, which could increase potential risks of personal injury due to IC blowup and/or burning.

4.2 DC Electrical Characteristics (1/3)

Ta = -20 to 85°C

Parameter		Symbol	Conditions	Min	Typ (Note 1)	Max	Unit
Supply voltage CVCC15=DVCC15 CVSS=DVSS=0V		DVCC15	fosc = 8 to 13.5MHz fs = 30kHz to 34kHz fsys = 30kHz to 54MHz PLLOFF="1"	1.35		1.65	V
		BVCC	fsys = 16kHz to 54MHz	1.8		3.3	
		DVCC3n (n=0 to 4)	fsys = 4 to 54MHz	1.65		3.3	
Low-level input voltage	P7 to P9 (Used as a port)	V _{IL1}	2.7V ≤ AVCC32 ≤ AVCC31 ≤ 3.3V	-0.3		0.3AVCC31 0.3AVCC32	V
	Normal port	V _{IL2}	1.65V ≤ DVCC3n ≤ 3.3V (n=0 to 4)			0.3DVCC3n 0.3BVCC	
			1.8V ≤ BVCC ≤ 3.3V				
	Schmitt-Triggered port	V _{IL3}	1.65V ≤ DVCC3n ≤ 3.3V (n=0 to 4) 1.8V ≤ BVCC ≤ 3.3V			0.2DVCC3n 0.2BVCC	
			1.35V ≤ DVCC15 ≤ 1.65V			0.1DVCC15	
	X1	V _{IL4}	1.35V ≤ CVCC15 ≤ 1.65V			0.1CVCC	
XT1	V _{IL5}	1.8V ≤ BVCC ≤ 3.3V	0.1CVCC				

Note1: BVCC : Normal mode 2.3V to 3.3V, BACKUP mode 1.8V to 3.3V

Ta = -20 to 85°C

Parameter		Symbol	Conditions	Min.	Typ (Note 1)	Max.	Unit
High-level input voltage	P7 to P9 (Used as a port)	V_{IH1}	$2.7V \leq AVCC32 \leq AVCC31 \leq 3.3V$	$0.7AVCC31$ $0.7AVCC32$		$DVCC3n+0.3$ $BVCC+0.3$ $DVCC15+0.2$ $CVCC+0.2$	V
	Normal port	V_{IH2}	$1.65V \leq DVCC3n \leq 3.3V$ (n=0 to 4)	$0.7DVCC3n$ $0.7BVCC$			
			$1.8V \leq BVCC \leq 3.3V$				
	Schmitt-Triggered port	V_{IH3}	$1.65V \leq DVCC3n \leq 3.3V$ (n=0 to 4)	$0.8DVCC3n$ $0.8BVCC$			
			$1.8V \leq BVCC \leq 3.3V$				
	X1	V_{IH4}	$1.35V \leq DVCC15 \leq 1.65V$	$0.9DVCC15$			
XT2	V_{IH4}	$1.35V \leq CVCC \leq 1.65V$	$0.9CVCC$				
Low-level output voltage		V_{OL}	$I_{OL} = 2mA$ $DVCC3n \geq 2.7V$ $I_{OL} = 500\mu A$ $DVCC3n < 2.7V$			0.4 $0.2DVCC3n \leq 0.4$	V
High-level output voltage		V_{OH}	$I_{OH} = -2mA$ $DVCC3n \geq 2.7V$ $I_{OH} = -500\mu A$ $DVCC3n < 2.7V$	2.4 $0.8DVCC3n$			

Note 1: Ta = 25°C, DVCC15=1.5V, DVCC3n =3.0V, BVCC=3.0V, AVCC3m=3.3V, unless otherwise noted

4.3 DC Electrical Characteristics (2/3)

Ta = -20 to 85°C

Parameter	Symbol	Conditions	Min.	Typ (Note 1)	Max.	Unit
Input leakage current	I_{LI}	$0.0 \leq V_{IN} \leq DVCC15$ $0.0 \leq V_{IN} \leq BVCC$ $0.0 \leq V_{IN} \leq DVCC3n$ (n=0 to 4) $0.0 \leq V_{IN} \leq AVCC31$ $0.0 \leq V_{IN} \leq AVCC32$		0.02	±5	μA
Output leakage current	I_{LO}	$0.2 \leq V_{IN} \leq DVCC15-0.2$ $0.2 \leq V_{IN} \leq BVCC-0.2$ $0.2 \leq V_{IN} \leq DVCC3n-0.2$ (n=0 to 4) $0.2 \leq V_{IN} \leq AVCC31-0.2$ $0.2 \leq V_{IN} \leq AVCC32-0.2$		0.05	±10	
Power-down voltage (STOP mode RAM backup)	V_{STOP} (DVCC15)		1.35		1.65	V
	V_{STOP1} (BVCC)		1.8		3.3	
	V_{STOP2} (AVCC3)	$V_{IL1} = 0.3AVCC31, 32$ $V_{IH1} = 0.7AVCC31, 32$	2.7		3.6	
	V_{STOP3} (DVCC3)	$V_{IL2} = 0.3DVCC3n, V_{IL3} = 0.1DVCC3n$ $V_{IH2} = 0.7DVCC3n, V_{IH3} = 0.9DVCC3n$ (n=0 to 4)	1.65		3.3	
Pull-up resistor at Reset	RRST	$DVCC15 = 1.5V \pm 0.15V$	20	50	150	kΩ
Schmitt-Triggered port	VTH	$1.65V \leq DVCC3n \leq 3.3V$ (n=0 to 4) $1.8V \leq BVCC \leq 3.3V$ $1.35V \leq DVCC15 \leq 1.65V$	0.3	0.6		V
Programmable pull-up/ pull-down resistor	PKH	$DVCC3n = 1.65V$ to $3.3V$ (n=0 to 4) $DVCC15 = 1.35V$ to $1.65V$ $BVCC = 1.8V$ to $3.3V$	20	50	150	kΩ
Pin capacitance (Except power supply pins)	C_{I0}	$F_c = 1MHz$			10	pF

Note 1: Ta = 25°C, DVCC15=1.5V, DVCC3n =3.0V, BVCC=3.0V, AVCC3m=3.3V, unless otherwise noted

4.4 DC Electrical Characteristics (3/3)

DVCC15=CVCC15=VCC15=1.35V to 1.65V, DVCC3n=VCC3=2.7V to 3.3V,
AVCC3m=2.7V to 3.3V, BVCC=1.8V to 3.3V

Ta = -20 to 85°C (n=0 to 4, m=1,2)

Parameter	Symbol	Conditions	Min.	Typ. (Note 1)	Max.	Unit	
NORMAL(Note 2): Gear = 1/1	ICC	F _{sys} = 54 MHz (f _{osc} = 13.5 MHz, PLLOFF="DVCC15")		50	60	mA	
IDLE (Doze)				18	28		
IDLE (HaIt)				14	23		
SLOW			F _{sys} = 32.768kHz (f _s = 32.768kHz)		300	970	μA
SLEEP			F _{sys} = 32.768kHz (f _s = 32.768kHz)		100	950	μA
STOP			DVCC15 = CVCC15 = 1.35 to 1.65V BVCC = 1.8 to 3.3V DVCC3n = 1.65 to 3.3V AVCC3m = 2.7 to 3.3V		90	900	μA
BACKUP			BVCC = 1.8 to 3.3V		3	5	μA

Note 1: Ta = 25°C, DVCC15=1.5V, DVCC3n=3.0V, BVCC=3.0V, AVCC3m=3.3V, unless otherwise noted

Note 2: Measured with the CPU dhrystone operating, all I/O peripherals channel on, and 16-bit external bus operated with 4 system clocks.

Note 3: The supply current flowing through the DVCC15, BVCC, DVCC3n, CVCC15 and AVCC3m pins is included in the digital supply current parameter (ICC).

4.5 10-bit ADC Electrical Characteristics

DVCC15=CVCC15=1.35V to 1.65V, AVCC3m=2.7V to 3.3V,
AVSS=DVSS, Ta= -20 to 85°C

Parameter	Symbol	Conditions	Min	Typ	Max	Unit
Analog reference voltage (+)	VREFH		2.7		3.3	V
			AVCC3m-0.3	AVCC	AVCC3m+0.3	
Analog reference voltage (-)	VREFL		AVSS	AVSS	AVSS+0.2	V
Analog input voltage	VAIN		VREFL		VREFH	V
Analog supply current	IREF	AVCC3m = VREFH = 3.0V ± 0.3V DVSS = AVSS = VREFL		1.15	1.8	mA
				AVCC3m = VREFH = 2.7 to 3.3V DVSS = AVSS = VREFL	0.1	10.0
Analog input capacitance	—			1.0	2.0	pF
Analog input impedance	—			2.0	3.5	kΩ
INL error	—	AVCC3m = VREFH = 3.0V ± 0.3V DVSS = AVSS = VREFL		±2	3	LSB
DNL error	—	AIN resistance < 1.3kΩ AIN load capacitance < 20 pF		±1	3	LSB
Offset error	—	AVCCm load capacitance ≥ 10 μF VREFH load capacitance ≥ 10 μF		±2	3	LSB
Gain error	—	Conversion time ≥ 7.85 μs		±2	4	LSB

Note 1: 1LSB = (VREFH - VREFL)/1024[V]

Note 2: The supply current flowing through the AVCC3m pin is included in the digital supply current parameter (ICC).

4.6 AC Electrical Characteristics

[1] Separate Bus mode

(1)DVCC15=CVCC15=VCC15=1.35V to 1.65V, DVCC3n=VCC3=2.3V to 3.3V

SYSCR3<ALESEL> = "0", 2 programmed wait state

No.	Parameter	Symbol	Equation		54 MHz (fsys)		Unit
			Min	Max	Min	Max	
1	System clock period (x)	t _{sys}	18.5				ns
2	A0-A23 valid to \overline{RD} , \overline{WR} or \overline{HWR} asserted	t _{AC}	(1+ALE) x-20		17		ns
3	A0-A23 hold after \overline{RD} , \overline{WR} or \overline{HWR} negated	t _{CAR}	x-14		4.5		ns
4	A0-A23 valid to D0-D15 Data in	t _{AD}		x (2+TW+ALE) -42		50.5	ns
5	\overline{RD} asserted to D0-D15 data in	t _{RD}		x (1+TW) -28		27.5	ns
6	\overline{RD} width low	t _{RR}	x (1+TW) -10		45.5		ns
7	D0-D15 hold after \overline{RD} negated	t _{HR}	0		0		ns
8	\overline{RD} negated to next A0-A23 output	t _{RAE}	x-15		3.5		ns
9	\overline{WR} / \overline{HWR} width low	t _{WW}	x (1+TW) -10		45.5		ns
10	\overline{WR} or \overline{HWR} asserted to D0-D15 valid	t _{DO}		12.3		12.3	ns
11	D0-D15 hold after \overline{WR} or \overline{HWR} negated	t _{DW}	x (1+TW) -18		37.5		ns
12	D0-D15 hold after \overline{WR} or \overline{HWR} negated	t _{WD}	x-15		3.5		ns
13	A0-A23 valid to \overline{WAIT} input	t _{AW}		x+ (ALE) x+ (TW-1) x -30		25.5	ns
14	\overline{WAIT} hold after \overline{RD} , \overline{WR} or \overline{HWR} asserted	t _{CW}	x (TW-3) +7	x (TW-1) -17	25.5	38.5	ns

Note 1: No. 1 to 13:

Internal 2 wait insertion , ALE "1" Clock, @54MHz

TW = (Auto wait insertion + 2N)

No. 14 :

Conditions (Auto wait insertion + 2N)

TW = 2 + 2*1 = 4

AC measurement conditions:

Output levels: High = 0.8DVCC33 V/Low 0.2DVCC33 V, CL = 30 pF

Input levels: High = 0.7DVCC33 V/Low 0.3DVCC33 V

(2) DVCC15=CVCC15=VCC15=1.35V to 1.65V, DVCC3n=VCC3=1.65V to 1.95V

SYSCR3<ALESEL> = "0", 2programmed wait state

No.	Parameter	Symbol	Equation		54 MHz (f _{sys})		Unit
			Min	Max	Min	Max	
1	System clock period (x)	t _{SYS}	18.5				ns
2	A0-A23 valid to \overline{RD} , \overline{WR} or \overline{HWR} asserted	t _{AC}	(1+ALE)x-20		17		ns
3	A0-A23 hold after \overline{RD} , \overline{WR} or \overline{HWR} negated	t _{CAR}	x-7		11.5		ns
4	A0-A23 valid to D0-D15 Data in	t _{AD}		x(2+TW+ALE)-42		50.5	ns
5	\overline{RD} asserted to D0-D15 data in	t _{RD}		x(1+TW)-28		27.5	ns
6	\overline{RD} width low	t _{RR}	x(1+TW)-10		45.5		ns
7	D0-D15 hold after \overline{RD} negated	t _{HR}	0		0		ns
8	\overline{RD} negated to next A0-A23 output	t _{RAE}	x-15		3.5		ns
9	\overline{WR} / \overline{HWR} width low	t _{WW}	x(1+TW)-10		45.5		ns
10	\overline{WR} or \overline{HWR} asserted to D0-D15 valid	t _{DO}		12.3		12.3	ns
11	D0-D15 hold after \overline{WR} or \overline{HWR} negated	t _{DW}	x(1+TW)-18		37.5		ns
12	D0-D15 hold after \overline{WR} or \overline{HWR} negated	t _{WD}	x-15		3.5		ns
13	A0-A23 valid to \overline{WAIT} input	t _{AW}		x+(ALE)x+(TW-1) x-30		25.5	ns
14	\overline{WAIT} hold after \overline{RD} , \overline{WR} or \overline{HWR} asserted	t _{CW}	x(TW-3)+7	x(TW-1)-17	25.5	38.5	ns

Note 1: No. 1 to 13:

Internal 2 wait insertion, ALE "1" Clock, @54MHz

TW = (Auto wait + 2N)

No. 14 :

Conditions (Auto wait insertion + 2N)

TW = 2 + 2*1 = 4

AC measurement conditions:

Output levels: High = 0.8DVCC33 V/Low 0.2DVCC33 V, CL = 30 pF

Input levels: High = 0.7DVCC33 V/Low 0.3DVCC33 V

(1) Read cycle timing (SYSCR3<ALESEL> = 0, 1 programmed wait state)

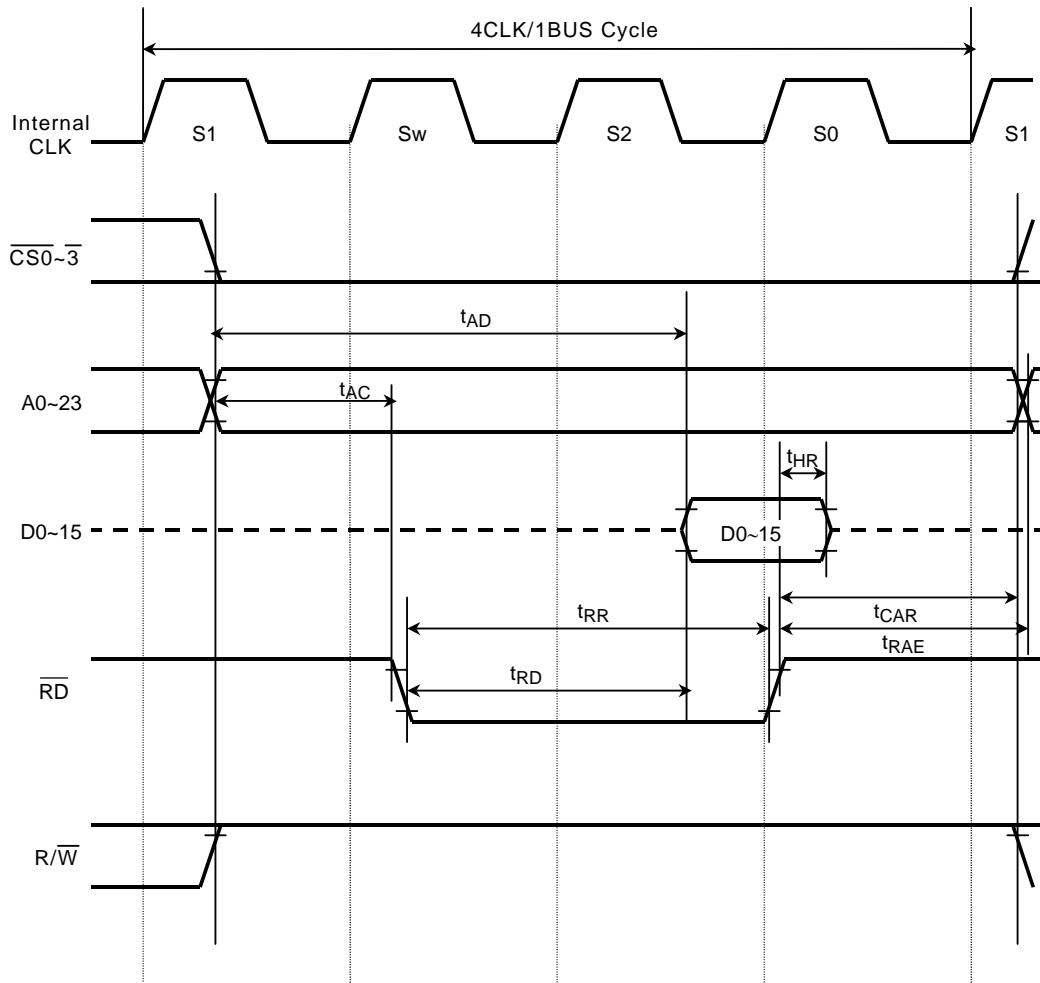

(2) Read cycle timing (SYSCR3<ALESEL> = 1, 1 programmed wait state)

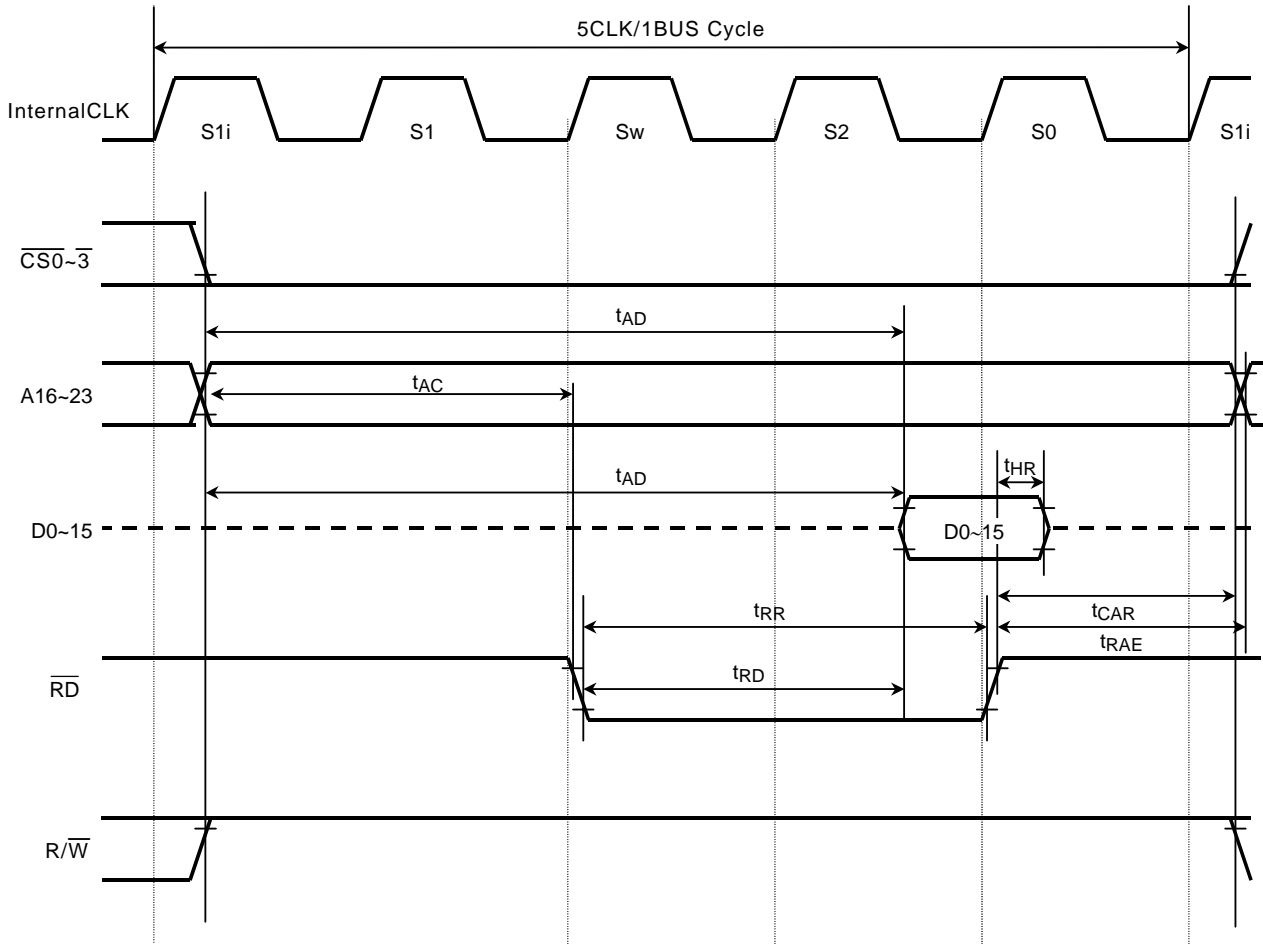

(2) Read cycle timing SYSCR3<ALESEL> = 1, 4 externally generated wait states with N = 1)

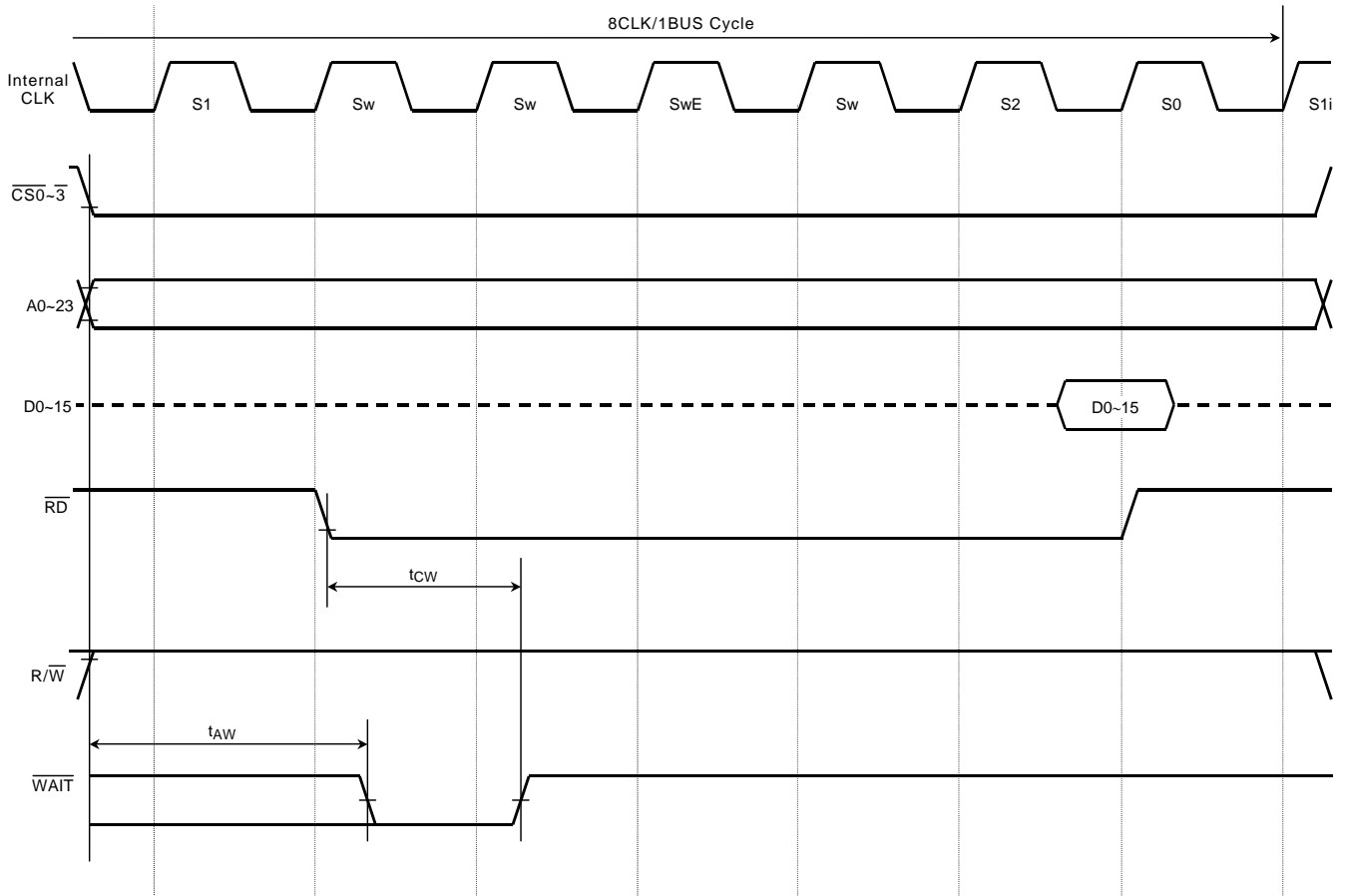

(4) Write cycle timing (SYSCR3<ALESEL> = 1, zero wait state)

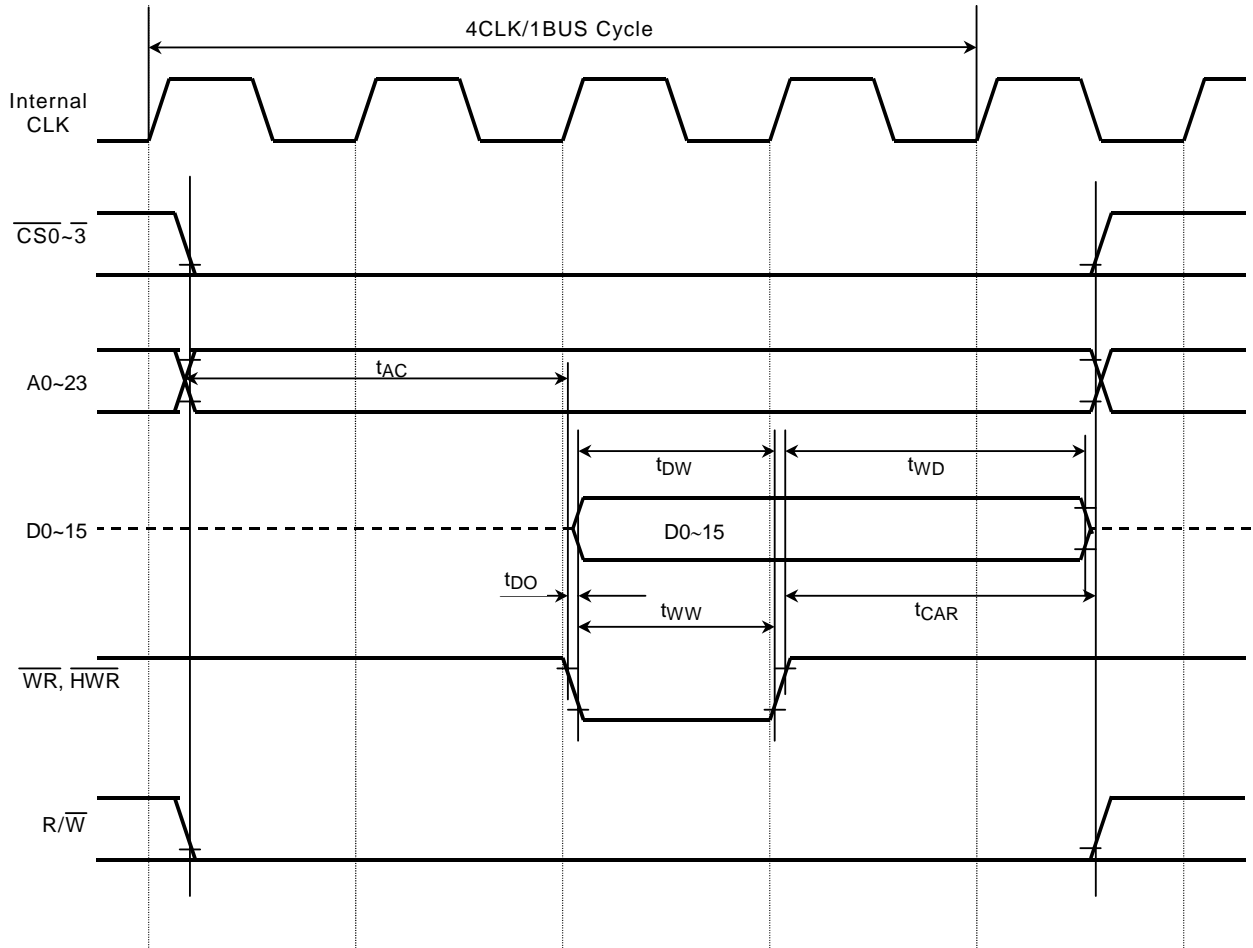

[2] Multiplex Bus mode

(1) DVCC15=CVCC15=VCC15=1.35V to 1.65V, DVCC3n=VCC3=2.3V to 3.3V

1. ALE width = 1 clock cycle, 2 programmed wait state

No.	Parameter	Symbol	Equation		54 MHz (f _{sys})		Unit
			Min	Max	Min	Max	
1	System clock period (x)	t _{SYS}	18.5				ns
2	A0-A15 valid to ALE low	t _{AL}	(ALE) x-12		6.5		ns
3	A0-A15 hold after ALE low	t _{LA}	x-8		10.5		ns
4	ALE pulse width high	t _{LL}	(ALE) x-6		12.5		ns
5	ALE low to \overline{RD} , \overline{WR} or \overline{HWR} asserted	t _{LC}	x-8		10.5		ns
6	\overline{RD} , \overline{WR} or \overline{HWR} negated to ALE high	t _{CL}	x-15		3.5		ns
7	A0-A15 valid to \overline{RD} , \overline{WR} or \overline{HWR} asserted	t _{ACL}	2x-20		17.0		ns
8	A16-A23 valid to \overline{RD} , \overline{WR} or \overline{HWR} asserted	t _{ACH}	2x-20		17.0		ns
9	A16-A23 hold after \overline{RD} , \overline{WR} or \overline{HWR} negated	t _{CAR}	x-14		4.5		ns
10	A0-A15 valid to D0-D15 Data in	t _{ADL}		x (2+TW+ALE) -42		50.5	ns
11	A16-A23 valid to D0-D15 Data in	t _{ADH}		x (2+TW+ALE) -42		50.5	ns
12	\overline{RD} asserted to D0-D15 data in	t _{RD}		x (1+TW) -28		27.5	ns
13	\overline{RD} width low	t _{RR}	x (1+TW) -10		45.5		ns
14	D0-D15 hold after \overline{RD} negated	t _{HR}	0		0		ns
15	\overline{RD} negated to next A0-A15 output	t _{RAE}	x-15		3.5		ns
16	$\overline{WR}/\overline{HWR}$ width low	t _{WW}	x (1+TW) -10		45.5		ns
17	D0-D15 valid to \overline{WR} or \overline{HWR} negated	t _{DW}	x (1+TW) -18		37.5		ns
18	D0-D15 hold after \overline{WR} or \overline{HWR} negated	t _{WD}	x-15		3.5		ns
19	A16-A23 valid to \overline{WAIT} input	t _{AWH}		x+ (ALE) x+ (TW-1) x-3 0		25.5	ns
20	A0-A15 valid to \overline{WAIT} input	t _{AWL}		x+ (ALE) x+ (TW-1) x-3 0		25.5	ns
21	\overline{WAIT} hold after \overline{RD} , \overline{WR} or \overline{HWR} asserted	t _{CW}	x (TW-3) +7	x (TW-1) -17	25.5	38.5	ns

Note 1: No. 1 to 20:

Internal 2 wait insertion , ALE “1” Clock, @54MHz

TW = (Auto wait insertion + 2N)

No. 21 :

Conditions (Auto wait + 2N)

TW = 2 + 2*1 = 4

AC measurement conditions:

Output levels: High = 0.8DVCC33 V/Low 0.2DVCC33 V, CL = 30 pF

Input levels: High = 0.7DVCC33 V/Low 0.3DVCC33 V

(2) DVCC15=CVCC15=VCC15=1.35V to 1.65V, DVCC3n=VCC3=1.65V to 1.95V

ALE width = 1 clock cycles, 2 programmed wait state

No.	Parameter	Symbol	Equation		54 MHz (f _{sys})		Unit
			Min	Max	Min	Max	
1	System clock period (x)	t _{sys}	18.5				ns
2	A0-A15 valid to ALE low	t _{AL}	(ALE)x-12		6.5		ns
3	A0-A15 hold after ALE low	t _{LA}	x-8		10.5		ns
4	ALE pulse width high	t _{LL}	(ALE)x-6		12.5		ns
5	ALE low to \overline{RD} , \overline{WR} or \overline{HWR} asserted	t _{LC}	x-8		10.5		ns
6	\overline{RD} , \overline{WR} or \overline{HWR} negated to ALE high	t _{CL}	x-15		3.5		ns
7	A0-A15 valid to \overline{RD} , \overline{WR} or \overline{HWR} asserted	t _{ACL}	2x-20		17.0		ns
8	A16-A23 valid to \overline{RD} , \overline{WR} or \overline{HWR} asserted	t _{ACH}	2x-20		17.0		ns
9	A16-A23 hold after \overline{RD} , \overline{WR} or \overline{HWR} negated	t _{CAR}	x-7		11.5		ns
10	A0-A15 valid to D0-D15 Data in	t _{ADL}		x(2+TW+ALE)-42		50.5	ns
11	A16-A23 valid to D0-D15 Data in	t _{ADH}		x(2+TW+ALE)-42		50.5	ns
12	\overline{RD} asserted to D0-D15 data in	t _{RD}		x(1+TW)-28		27.5	ns
13	\overline{RD} width low	t _{RR}	x(1+TW)-10		45.5		ns
14	D0-D15 hold after \overline{RD} negated	t _{HR}	0		0		ns
15	\overline{RD} negated to next A0-A15 output	t _{RAE}	x-15		3.5		ns
16	$\overline{WR}/\overline{HWR}$ width low	t _{WW}	x(1+TW)-10		45.5		ns
17	D0-D15 valid to \overline{WR} or \overline{HWR} negated	t _{DW}	x(1+TW)-18		37.5		ns
18	D0-D15 hold after \overline{WR} or \overline{HWR} negated	t _{WD}	x-15		3.5		ns
19	A16-A23 valid to \overline{WAIT} input	t _{AWH}		x+(ALE)x+(TW-1)x-3 0		25.5	ns
20	A0-A15 valid to \overline{WAIT} input	t _{AWL}		x+(ALE)x+(TW-1)x-3 0		25.5	ns
21	\overline{WAIT} hold after \overline{RD} , \overline{WR} or \overline{HWR} asserted	t _{CW}	x(TW-3)+7	x(TW-1)-17	25.5	38.5	ns

Note 1: No. 1 to 20:

Internal 2 wait insertion, ALE "1" Clock, @54MHz

TW = (Auto insert wait + 2N)

No. 21 :

Conditions (Auto 2 waits insertion + 2N)

TW = 2 + 2*1 = 4

AC measurement conditions:

Output levels: High = 0.8DVCC33 V/Low 0.2DVCC33 V, CL = 30 pF

Input levels: High = 0.7DVCC33 V/Low 0.3DVCC33 V

(1) Read cycle timing, ALE width = 1 clock cycle, 1 programmed wait state

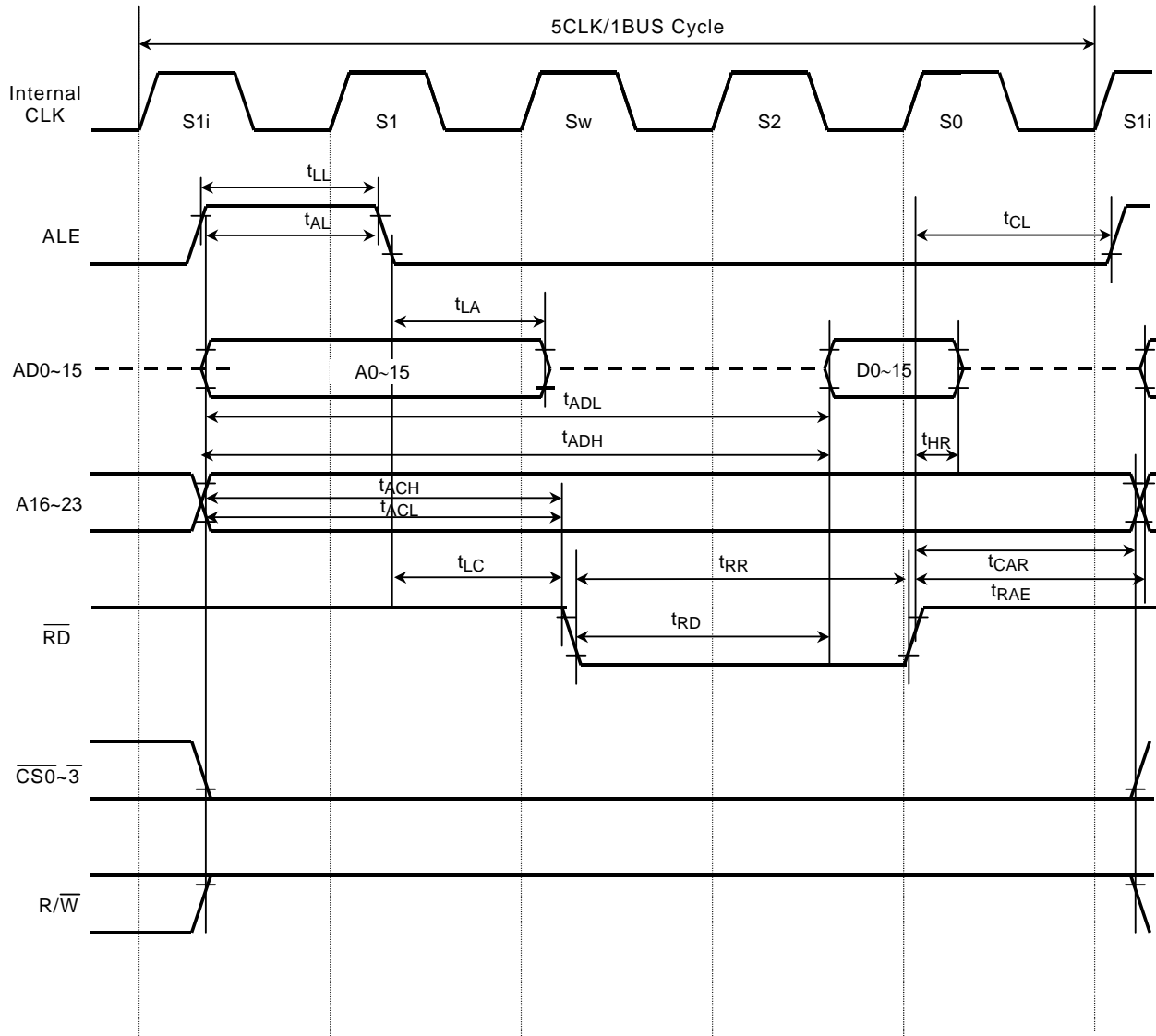

(2) Read cycle timing, ALE width = 1 clock cycle, 2 programmed wait state

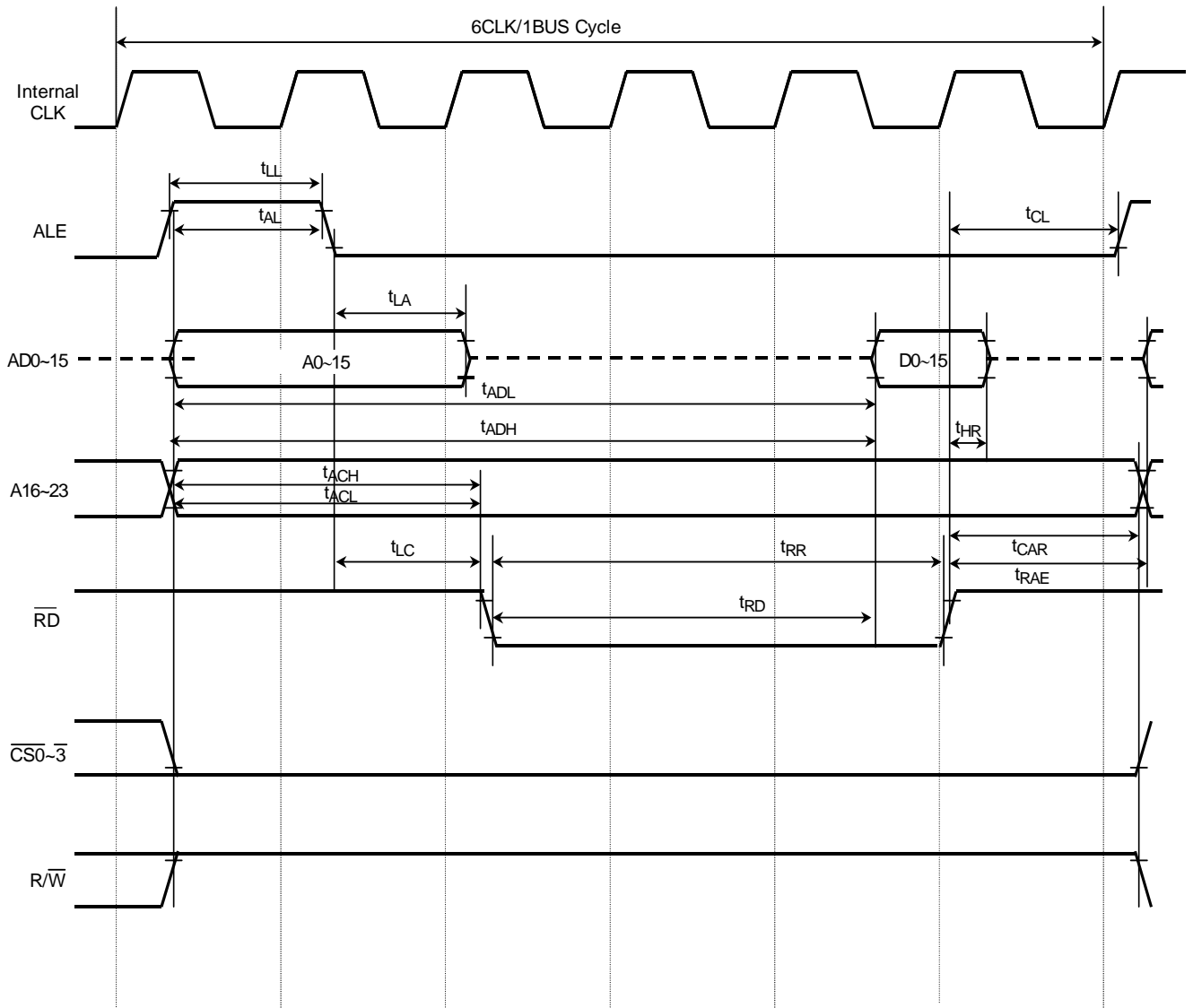

(3) Read cycle timing, ALE width = 1 clock cycle, 4 programmed wait state

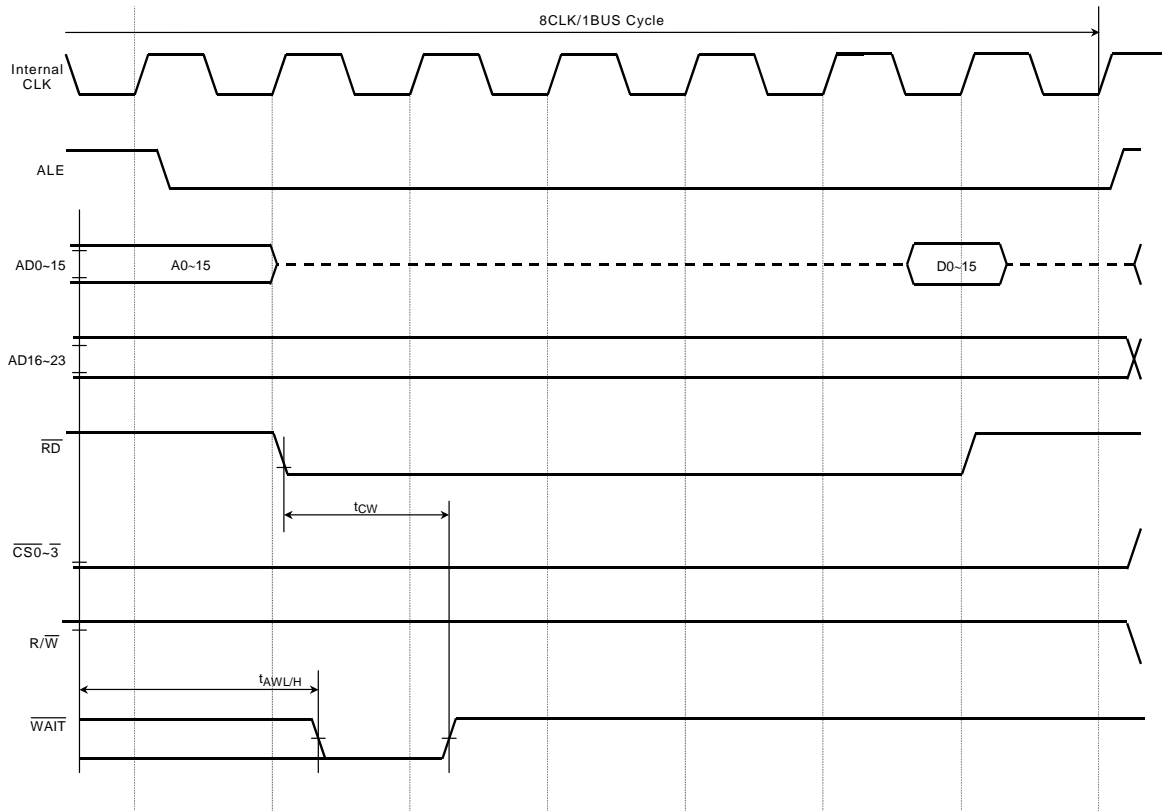

(4) Read cycle timing, ALE width = 2 clock cycle, 1 programmed wait state

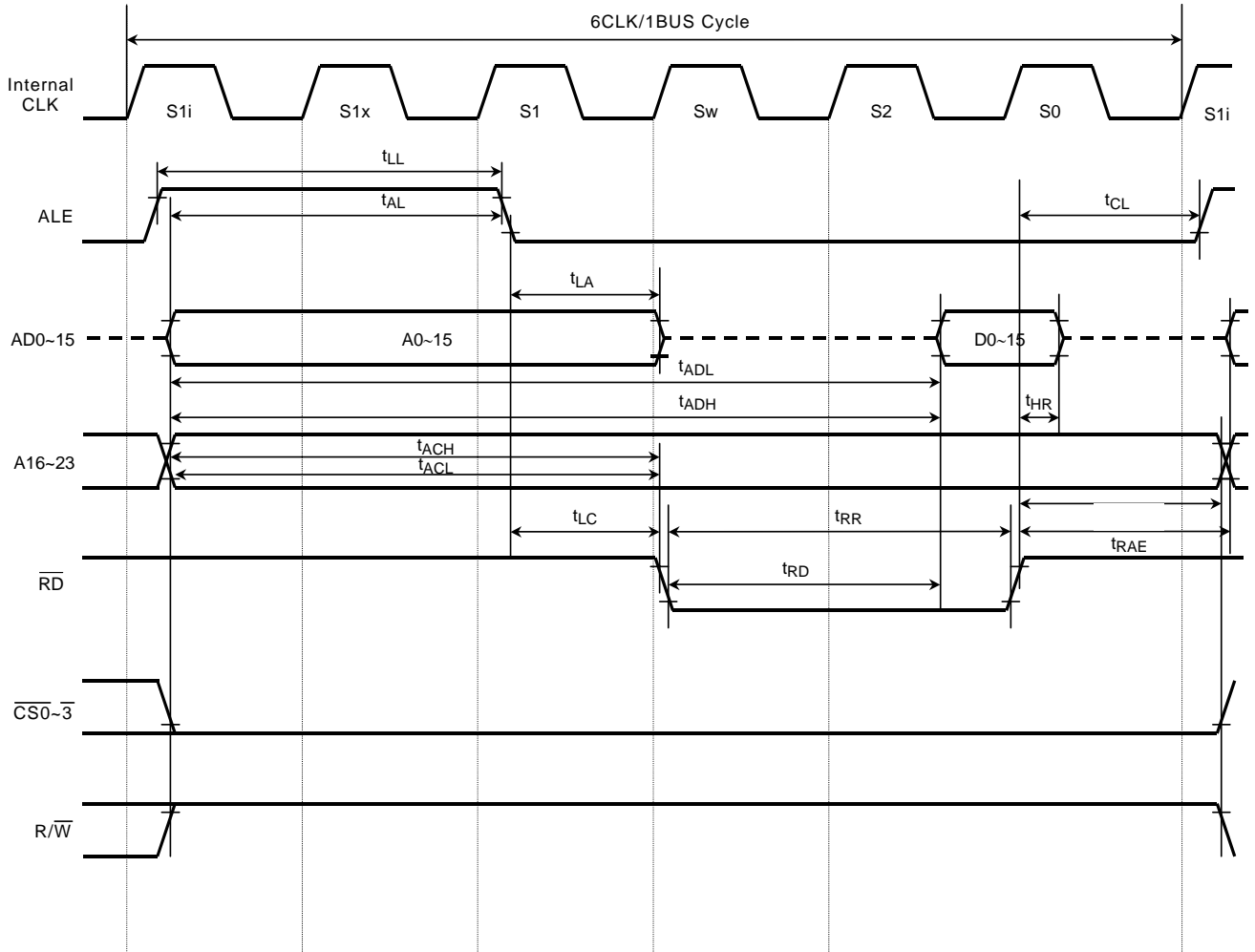

(5) Read cycle timing, ALE width = 2 clock cycle, 4 programmed wait state

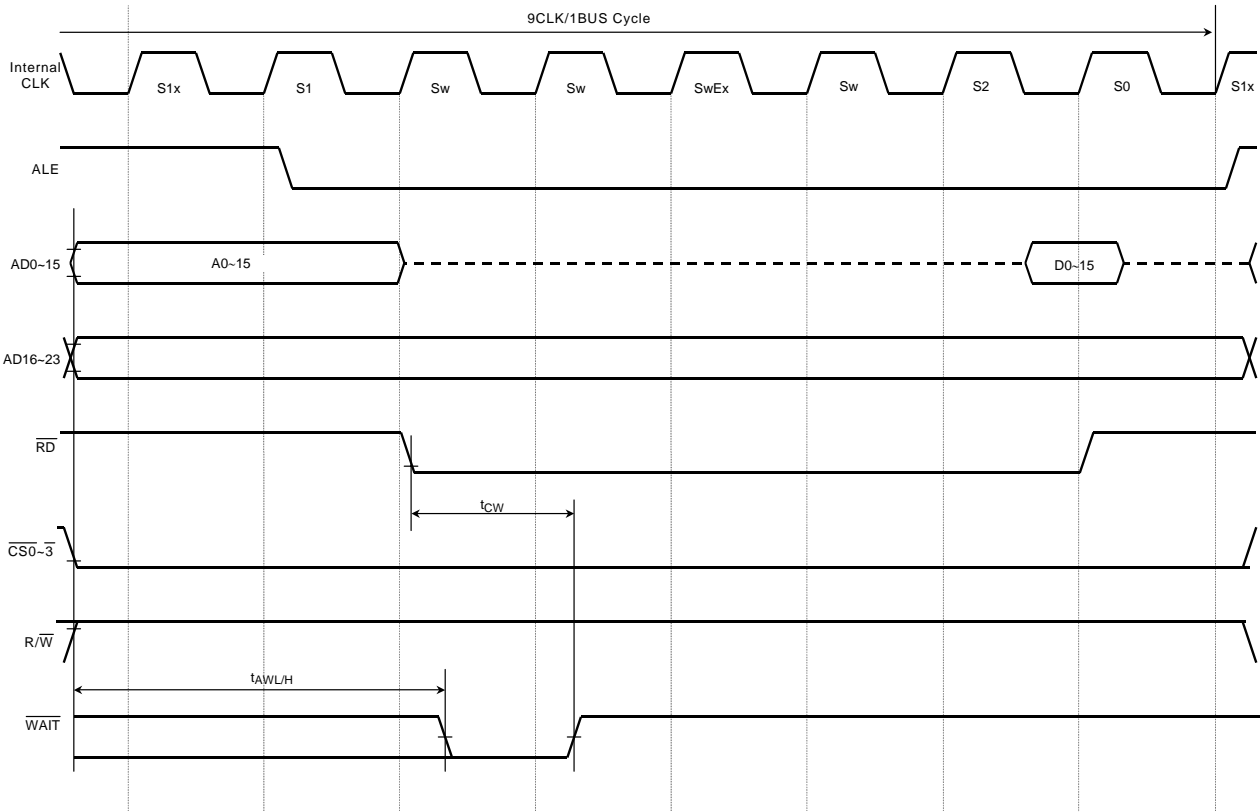

(6) Write cycle timing, ALE width = 2 clock cycles, zero wait state

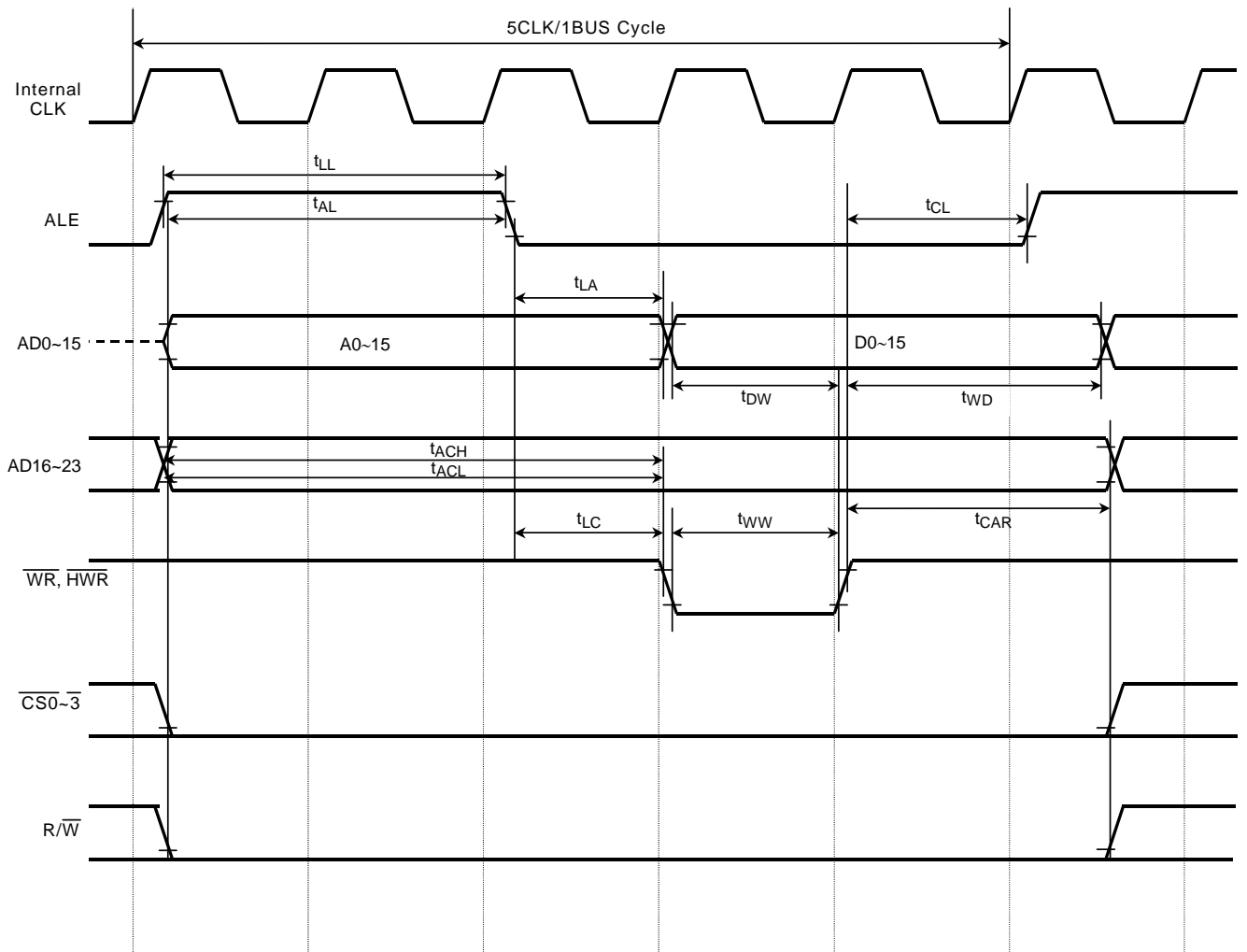

(7) Write cycle timing, ALE width = 1 clock cycles, 2 wait state

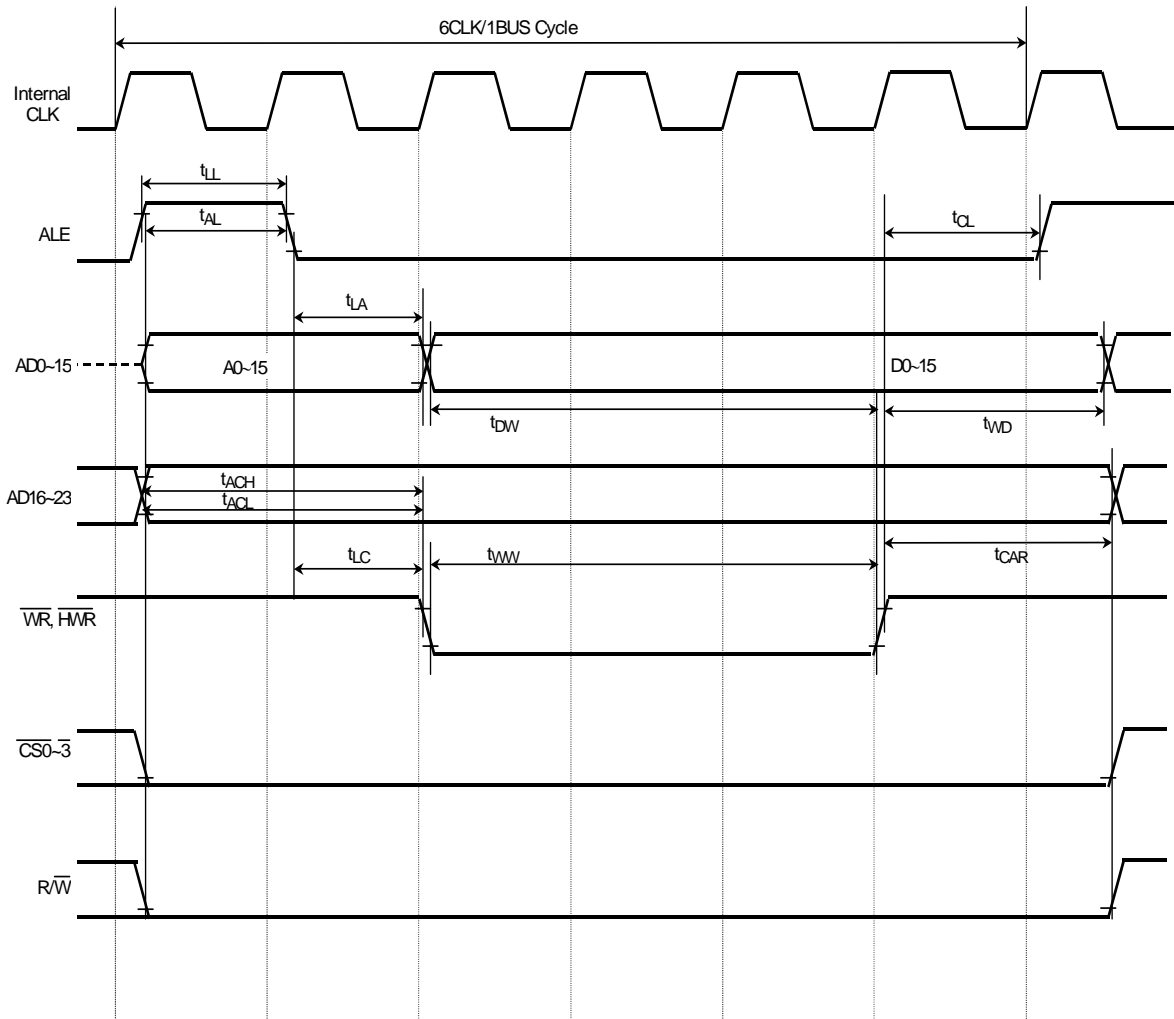

(8) Write cycle timing, ALE width = 2 clock cycles, 4 wait state

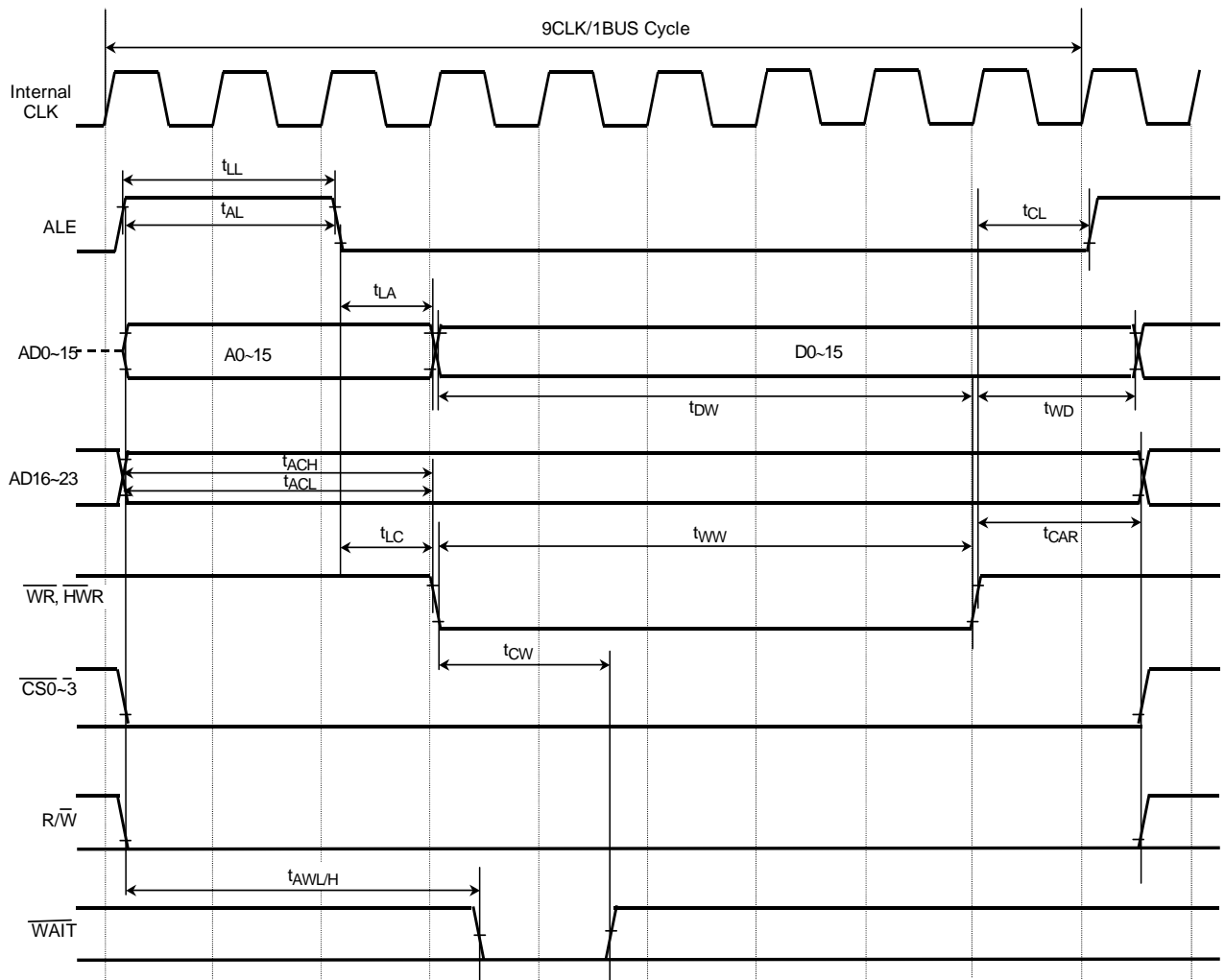

4.7 Transfer with DMA Request

The following shows an example of a transfer between the on-chip RAM and an external device in multiplex bus mode.

- 16-bit data bus width, non-recovery time
- Level data transfer mode
- Transfer size of 16 bits, device port size (DPS) of 16 bits
- Source/destination: on-chip RAM/external device

The following shows transfer operation timing of the on-chip RAM to an external bus during write operation (memory-to-memory transfer).

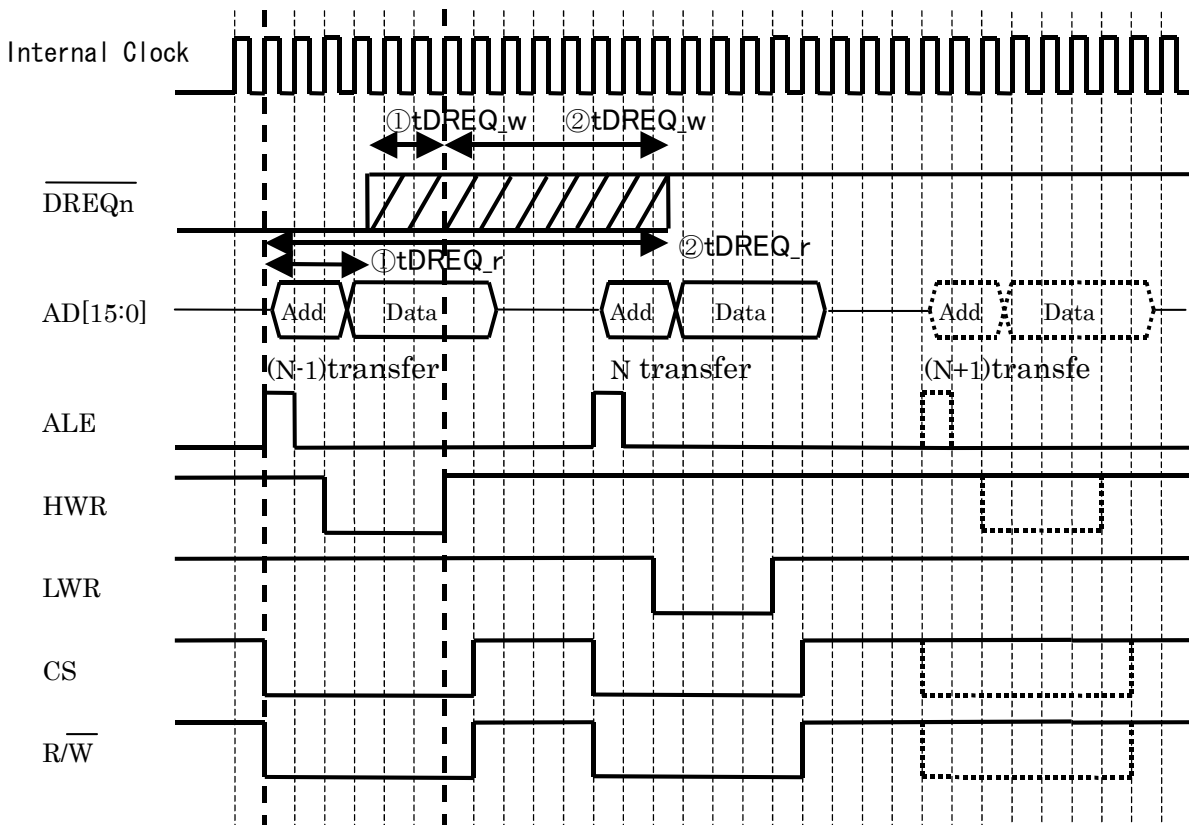

- (1) Indicates the condition under which Nth transfer is performed successfully.
- (2) Indicates the condition under which (N + 1)th transfer is not performed.

- (1) DVCC15=CVCC15=VCC15= 1.35V to 1.65V, AVCC3m=VCC3=2.7V to 3.3V
DVCC33=2.3V to 3.3V, DVCC30/31/32/34=1.65V to 3.3V, Ta= -20 to 85°C (m=1 to 2)

No.	Parameter	Symbol	Equation		54 MHz (f _{sys})		Unit
			(1)Min	(2)Max	Min	Max	
2	\overline{RD} asserted to \overline{DREQn} negated (external device to on-chip RAM transfer)	tDREQ_r	(W+1)x	(2W+ALE+8)x -51	37	152.5	ns
3	$\overline{WR}/\overline{HWR}$ rising to \overline{DREQn} negated (on-chip RAM to external device transfer)	tDREQ_w	-(W+2)x	(5+WAIT)x-51.8	-55.5	59.2	ns

- (2) DVCC15=CVCC15=VCC15=1.35V to 1.65V, AVCC3m =VCC3=2.7V to 3.3V
DVCC33=1.65V to 1.95V, DVCC30/31/32/34=1.65V to 3.3V, Ta= -20 to 85°C (m=1 to 2)

No.	Parameter	Symbol	Equation		54 MHz (f _{sys})		Unit
			(1)Min	(2)Max	Min	Max	
2	\overline{RD} asserted to \overline{DREQn} negated (external device to on-chip RAM transfer)	tDREQ_r	(W+1) x	(2W+ALE+8) x-56	37	147.5	ns
3	$\overline{WR}/\overline{HWR}$ rising to \overline{DREQn} negated (on-chip RAM to external device transfer)	tDREQ_w	-(W+2)x	(5+WAIT)x-56.8	-55.5	54.2	ns

W: Number of wait-state cycles inserted. In the case of (2 + N) externally generated wait states with N = 1, W becomes 4

ALE: Apply ALE = ALE 1 clock, ALE = 1 for ALE 2 clock. The values in the above table are obtained with W = 1, ALE = 1.

4.8 Serial Channel Timing

(1) I/O Interface mode (DVCC3n = 1.65V to 3.3V)

In the table below, the letter x represents the fsys cycle period, which varies depending on the programming of the clock gear function.

(1) SCLK input mode (SIO0 to SIO6)

Parameter	Symbol	Equation		54 MHz		Unit
		Min	Max	Min	Max	
SCLK period	t_{SCY}	12x		222		ns
SCLK Clock High width(input)	T_{scH}	6x		111		ns
SCLK Clock Low width (input)	T_{scL}	6x		111		ns
TxD data to SCLK rise or fall*	t_{OSS}	2x-30		6		ns
TxD data hold after SCLK rise or fall*	t_{OHS}	8x-15		129		ns
RxD data valid to SCLK rise or fall*	t_{SRD}	30		30		ns
RxD data hold after SCLK rise or fall*	t_{HSR}	2x+30		66		ns

* SCLK rise or fall: Measured relative to the programmed active edge of SCLK.

2. SCLK output mode (SIO0 to SIO6)

Parameter	Symbol	Equation		54 MHz		Unit
		Min	Max	Min	Max	
SCLK period	t_{SCY}	8x		222		ns
TxD data to SCLK rise or fall*	t_{OSS}	4x-10		62		ns
TxD data hold after SCLK rise or fall*	t_{OHS}	4x-10		62		ns
RxD data valid to SCLK rise or fall*	t_{SRD}	45		45		ns
RxD data hold after SCLK rise or fall*	t_{HSR}	0		0		ns

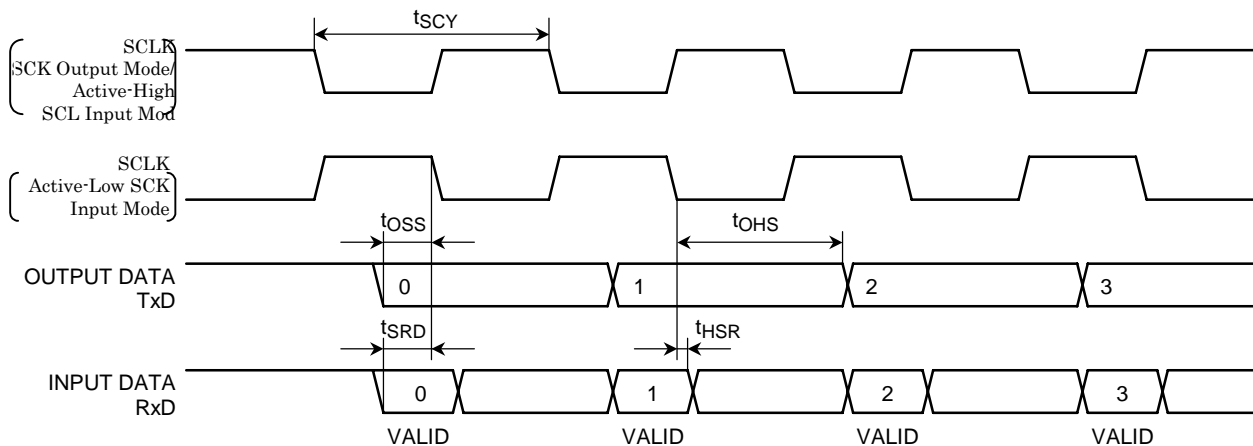

4.9 SBI Timing

(1) I2C mode

In the table below, the letters x represent the fsys periods, respectively.

n denotes the value of n programmed into the SCK (SCL output frequency select) field in the SBI0CR1.

Parameter	Symbol	Equation		Standard mode		Fast mode		Unit
		Min	Max	Min	Max	Min	Max	
SCL clock frequency	t _{SCL}	0		0	100	0	400	kHz
Hold time for START condition	t _{HD:STA}			4.0		0.6		μs
SCL clock low width (Input) (Note 1)	t _{LOW}			4.7		1.3		μs
SCL clock high width (Output) (Note 2)	t _{HIGH}			4.0		0.6		μs
Setup time for a repeated START condition	t _{SU:STA}	(Note 5)		4.7		0.6		μs
Data hold time (Input) (Note 3, 4)	t _{HD:DAT}			0.0		0.0		μs
Data setup time	t _{SU:DAT}			250		100		ns
Setup time for STOP condition	t _{SU:STO}			4.0		0.6		μs
Bus free time between STOP and START conditions	t _{BUF}	(Note 5)		4.7		1.3		μs

Note 1: SCL clock low width (output) is calculated with: $(2^{n-1} + 58)/(f_{sys}/2)$

Note 2: SCL clock high width (output) is calculated with $(2^{n-1} + 12)/(f_{sys}/2)$

Notice: On I²C-bus specification, Maximum Speed of Standard mode is 100KHz ,Fast mode is 400Khz. Internal SCL clock Frequency setting should be shown above Note1 & Note2.

Note 3: The output data hold time is equal to 12x

Note 4: The Philips I²C-bus specification states that a device must internally provide a hold time of at least 300 ns for the SDA signal to bridge the undefined region of the fall edge of SCL. However, the 19A64 SBI does not satisfy this requirement. Also, the output buffer for SCL does not incorporate slope control of the falling edges; therefore, the equipment manufacturer should design so that the input data hold time shown in the table is satisfied, including tr/tf of the SCL and SDA lines.

Note 5: Software-dependent

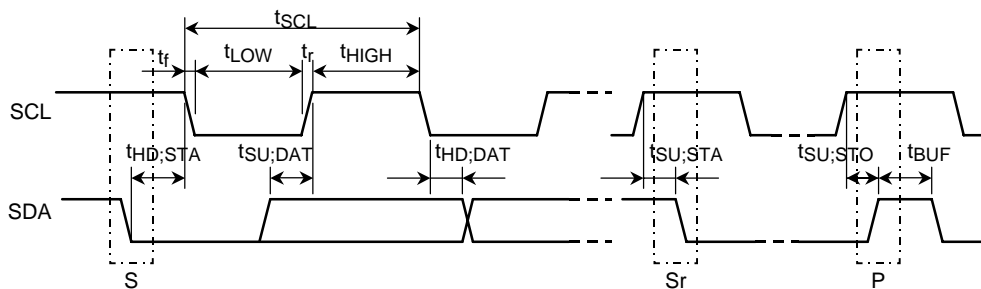

S: START condition
 Sr: Repeated START condition
 P: STOP condition

(2) Clock-Synchronous 8-Bit SIO mode

In the tables below, the letters x represent the fsys cycle periods, respectively. The letter n denotes the value of n programmed into the SCK (SCL output frequency select) field in the SBI0CR1.

The electrical specifications below are for an SCK signal with a 50% duty cycle.

③ SCK Input mode

Parameter	Symbol	Equation		54 MHz		Unit
		Min	Max	Min	Max	
SCK period	t_{SCY}	16x		296		ns
SO data to SCK rise	t_{OSS}	$(t_{SCY}/2) - (6x + 30)$		7		ns
SO data hold after SCK rise	t_{OHS}	$(t_{SCY}/2) + 4x$		222		ns
SI data valid to SCK rise	t_{SRD}	0		0		ns
SI data hold after SCK rise	t_{HSR}	4x + 10		84		ns

④ SCK Output mode

Parameter	Symbol	Equation		54 MHz		Unit
		Min	Max	Min	Max	
SCK period (programmable)	t_{SCY}	16x		296		ns
SO data to SCK rise	t_{OSS}	$(t_{SCY}/2) - 20$		128		ns
SO data hold after SCK rise	t_{OHS}	$(t_{SCY}/2) - 20$		128		ns
SI data valid to SCK rise	t_{SRD}	2x + 30		67		ns
SI data hold after SCK rise	t_{HSR}	0		0		ns

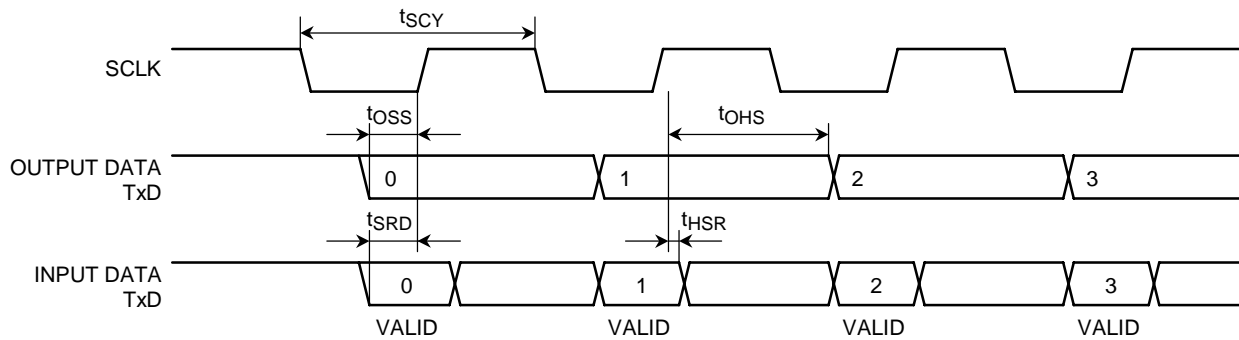

4.10 Event Counter

In the table below, the letter x represents the fsys cycle period.

Parameter	Symbol	Equation		54 MHz		Unit
		Min	Max	Min	Max	
Clock low pulse width	t_{VCKL}	$2X + 100$		137		ns
Clock high pulse width	t_{VCKH}	$2X + 100$		137		ns

4.11 Timer Capture

In the table below, the letter x represents the fsys cycle period.

Parameter	Symbol	Equation		54 MHz		Unit
		Min	Max	Min	Max	
Low pulse width	t_{CPL}	$2X + 100$		137		ns
High pulse width	t_{CPH}	$2X + 100$		137		ns

4.12 General Interrupts

In the table below, the letter x represents the fsys cycle period.

Parameter	Symbol	Equation		54 MHz		Unit
		Min	Max	Min	Max	
Low pulse width for INTO-INTA	t_{INTAL}	$X + 100$		118.5		ns
High pulse width for INTO-INTA	t_{INTAH}	$X + 100$		118.5		ns

4.13 \overline{NMI} and STOP /SLEEP Wake-up Interrupts

Parameter	Symbol	Equation		54 MHz		Unit
		Min	Max	Min	Max	
Low pulse width for \overline{NMI} and INTO-INT4	t_{INTBL}	100		100		ns
High pulse width for INTO-INT4	t_{INTBH}	100		100		ns

4.14 SCOUT Pin

Parameter	Symbol	Equation		54 MHz		Unit
		Min	Max	Min	Max	
Clock high pulse width	t_{SCH}	$0.5T - 5$		4.25		ns
Clock low pulse width	t_{SCL}	$0.5T - 5$		4.25		ns

Note: In the above table, the letter T represents the cycle period of the SCOUT output clock.

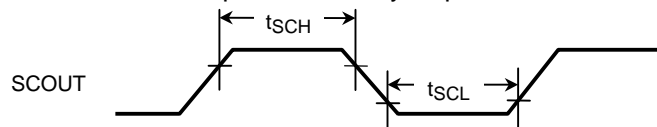

4.15 Bus Request and Bus Acknowledge Signals

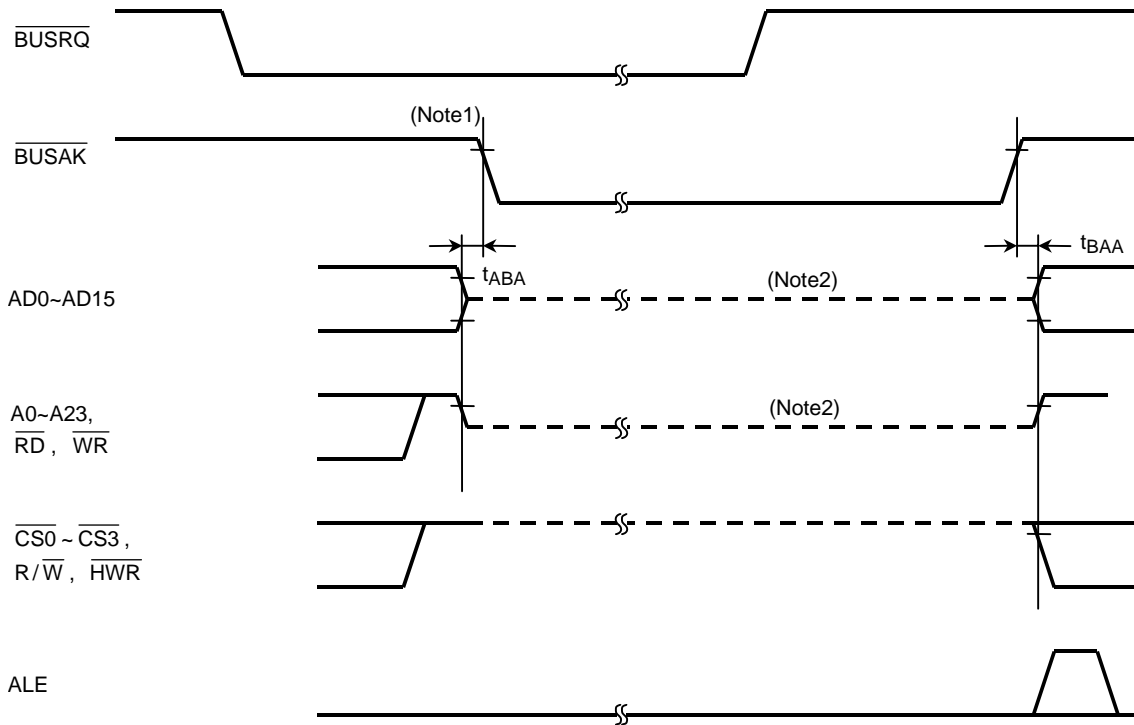

Parameter	Symbol	Equation		54 MHz		Unit
		Min	Max	Min	Max	
Bus float to $\overline{\text{BUSAK}}$ asserted	t_{ABA}	0	80	0	80	ns
Bus float after $\overline{\text{BUSAK}}$ negated	t_{BAA}	0	80	0	80	ns

Note 1: If the current bus cycle has not terminated due to wait-state insertion, the TMP19A64F20AXBG does not respond to $\overline{\text{BUSRQ}}$ until the wait state ends.

Note 2: This broken line indicates that output buffers are disabled, not that the signals are at indeterminate states. The pin holds the last logic value present at that pin before the bus is relinquished. This is dynamically accomplished through external load capacitances. The equipment manufacturer may maintain the bus at a predefined state by means of off-chip restores, but he or she should design, considering the time (determined by the CR constant) it takes for a signal to reach a desired state. The on-chip, integrated programmable pullup/pulldown resistors remain active, depending on internal signal states.

4.16 KWUP Input

Pull-up Register Active

Parameter	Symbol	Equation		54 MHz		Unit
		Min	Max	Min	Max	
Low pulse width for KEY0-D	$t_{ky_{TBL}}$	$X+100$		118		ns
High pulse width for KEY0-D	$t_{ky_{TBH}}$	$X+100$		118		ns

4.17 Dual Pulse Input

Parameter	Symbol	Equation		54 MHz		Unit
		Min	Max	Min	Max	
Dual input pulse period	T_{dcyc}	$8Y$		296		ns
Dual input pulse setup	T_{abs}	$Y+20$		57		ns
Dual input pulse hold	T_{abh}	$Y+20$		57		ns

Y: Sampling clock ($f_{sys}/2$)

