

**DESCRIPTION**

The LX5512B is a power amplifier optimized for WLAN applications in the 2.4-2.5 GHz frequency range. The PA is implemented as a three-stage monolithic microwave integrated circuit (MMIC) with active bias and input/output pre-matching. The device is manufactured with an InGaP/GaAs Heterojunction Bipolar Transistor (HBT) IC process (MOCVD). It operates at a single low voltage supply of 3.3V with 32 dB power gain between 2.4-2.5GHz, at a low quiescent current of 65mA.

For 19dBm OFDM output power (64QAM, 54Mbps), the PA provides a low EVM (Error-Vector Magnitude) of 3%, and consumes 140mA total DC current.

The LX5512B is available in a 16-pin 3mmx3mm micro-lead package (MLP). The compact footprint, low profile, and excellent thermal capability of LX5512B meets the requirements of high-gain power amplifiers for IEEE 802.11b/g applications.

**KEY FEATURES**

- Advanced InGaP HBT
- 2.4-2.5GHz Operation
- Single-Polarity 3.3V Supply
- Low Quiescent Current  $I_{CQ}$  ~65mA
- Power Gain ~ 32 dB at 2.45GHz &  $P_{out}$ =19dBm
- Total Current ~140mA for  $P_{out}$ =19dBm at 2.45 GHz OFDM
- EVM ~3 % for 64QAM/ 54Mbps &  $P_{out}$ =19dBm
- Small Footprint: 3x3mm<sup>2</sup>
- Low Profile: 0.9mm

**IMPORTANT:** For the most current data, consult MICROSEMI's website: <http://www.microsemi.com>

**APPLICATIONS**

- IEEE 802.11b/g

**PRODUCT HIGHLIGHT**

**PACKAGE ORDER INFO**
**LQ**
**Plastic MLPQ  
16 pin**

RoHS Compliant / Pb-free

**LX5512BLQ**

Note: Available in Tape & Reel. Append the letters "TR" to the part number.  
(i.e. LX5512BLQ-TR)

This device is classified as ESD Level 0 in accordance with JESD22-A114-B, (HBM) testing. Appropriate ESD procedures should be observed when handling this device.

**ABSOLUTE MAXIMUM RATINGS**

DC Supply Voltage, RF off.....	7V
Collector Current.....	500mA
Total Power Dissipation.....	2W
RF Input Power.....	5dBm
Operation Ambient Temperature.....	-40 to +85°C
Storage Temperature.....	-65 to +150°C
Package Peak Temp for Solder Reflow (40 Seconds Maximum Exposure).....	260°C(+0, -5)

Note: Exceeding these ratings could cause damage to the device. All voltages are with respect to Ground. Currents are positive into, negative out of specified terminal.

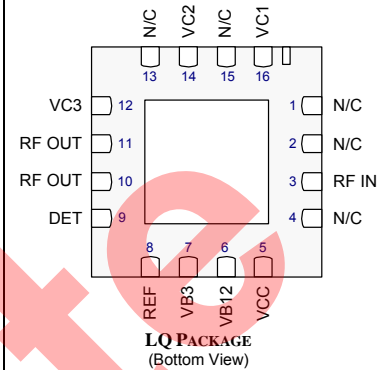
**PACKAGE PIN OUT**

RoHS / Pb-free 100% Matte Tin Lead Finish

**THERMAL DATA**
**LQ Plastic MLPQ 16-Pin**

THERMAL RESISTANCE-JUNCTION TO CASE, $\theta_{JC}$	<b>10°C/W</b>
THERMAL RESISTANCE-JUNCTION TO AMBIENT, $\theta_{JA}$	<b>50°C/W</b>

Junction Temperature Calculation:  $T_J = T_A + (P_D \times \theta_{JA})$ .

The  $\theta_{JA}$  numbers are guidelines for the thermal performance of the device/pc-board system. All of the above assume no ambient airflow.

**FUNCTIONAL PIN DESCRIPTION**

Name	Description
RF IN	RF input for the power amplifier. This pin is directly connected to base, a 10pF decoupling capacitor may be needed.
VB12	Bias current control voltage for the first and second stage.
VB3	Bias current control voltage for the third stage. The VB3 pin can be connected with the first and second stage control voltage (VB12) into a single reference voltage (referred to as $V_{REF}$ ) through an external resistor bridge.
VCC	Supply voltage for the bias reference and control circuits. The VCC feed line should be terminated with a 10nF bypass capacitor close to connector pin. This pin can be combined with VC1, VC2 and VC3 pins, resulting in a single supply voltage (referred to as $V_C$ ).
RF OUT	RF output for the power amplifier. This pin is DC-decoupled from the transistor collector of the third stage.
VC1	Power supply for first stage amplifier. The VC1 feed line should be terminated with a 10pF bypass capacitor, followed by a 36 Ohm resistor. This pin can be combined with VC2, VC3 and VCC pins, resulting in a single supply voltage (referred to as $V_C$ ).
VC2	Power supply for second stage amplifier. The VC2 feed line should be terminated with a 18pF bypass capacitor. This pin can be combined with VC1, VC3 and VCC pins, resulting in a single supply voltage (referred to as $V_C$ ).
VC3	Power supply for the third stage amplifier. The VC3 feed line should be terminated with 27 pF and 10 nF bypass capacitors. This pin can be combined with VC1, VC2 and VCC pins, resulting in a single supply voltage (referred to as $V_C$ ).
REF	Power detector reference output pin should be terminated with a 100K $\Omega$ loading resistor
DET	Power detector output pin should be terminated with a 100K $\Omega$ loading resistor
GND	The center metal base of the MLP package provides both DC and RF ground as well as heat sink for the power amplifier.

**ELECTRICAL CHARACTERISTICS**

 Test conditions:  $V_C = 3.3V$ ,  $V_{REF} = 2.95V$ ,  $I_{CQ} = 65mA$ ,  $T_A = 25^\circ C$ 

Parameter	Symbol	Test Conditions	LX5512B			Units
			Min	Typ	Max	
Frequency Range	f		2.4		2.5	GHz
Power Gain @ $P_{OUT} = 19dBm$	Gp			32		dB
EVM @ $P_{OUT} = 19dBm$		64QAM / 54Mbps		3.0		%
Total Current @ $P_{OUT} = 19dBm$	$I_{C\_TOTAL}$			140		mA
Quiescent Current	$I_{CQ}$			65		mA
Bias Control Reference Current	$I_{REF}$	For $I_{CQ} = 65mA$		1.8		mA
Small-Signal Gain	S21			32		dB
Gain Flatness	$\Delta S21$	Over 100MHz		$\pm 0.25$		dB
Gain Variation Over Temperature	$\Delta S21$	0 to $+85^\circ C$		$\pm 0.25$		dB
Input Return Loss	S11			10		dB
Output Return Loss	S22			10		dB
Reverse Isolation	S12			45		dB
Second Harmonic		$P_{OUT} = 19dBm$		-40		dBc
Third Harmonic		$P_{OUT} = 19dBm$		-40		dBc
Total Current @ $P_{OUT} = 23dBm$		11Mbps CCK		215		mA
2 <sup>nd</sup> Side Lobe @ 23dBm		11Mbps CCK		-55		dBc
Ramp-On Time	$t_{ON}$	10 ~ 90%			100	ns
Differential Detector Response		19dBm OFDM		1.4		V

Note: All measured data was obtained on a 10mil GETEK evaluation board without heat sink.

Obsoleto

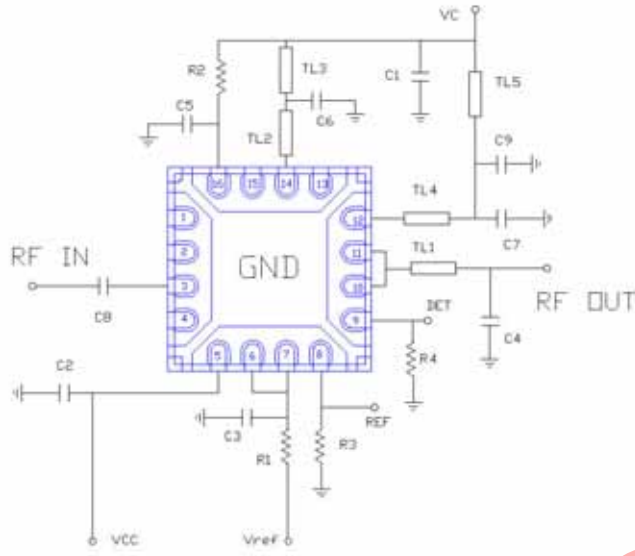
**APPLICATION SCHEMATIC & BILL OF MATERIALS**

Recommended BOM

Location	Value
C1	1 $\mu$ F (0603)
C2,C3,C9	10nF(0402)
C4	2pF (0402)
C5,C8	10pF (0402)
C6	18pF (0402)
C7	27pF (0402)
R1	75 $\Omega$ (0402)
R2	36 $\Omega$ (0402)
R3,R4	100 k $\Omega$ (0402)
TL1	120/10 mil (L/W)
TL2	100/8 mil (L/W)
TL3	~350/8 mil (L/W)
TL4	40/8 mil (L/W)
TL5	~500/8 mil (L/W)
Substrate	10 mil GETEK
	$\epsilon_r = 3.9, \tan \delta = 0.01$
	50 $\Omega$ Microstrip width: 20 mil

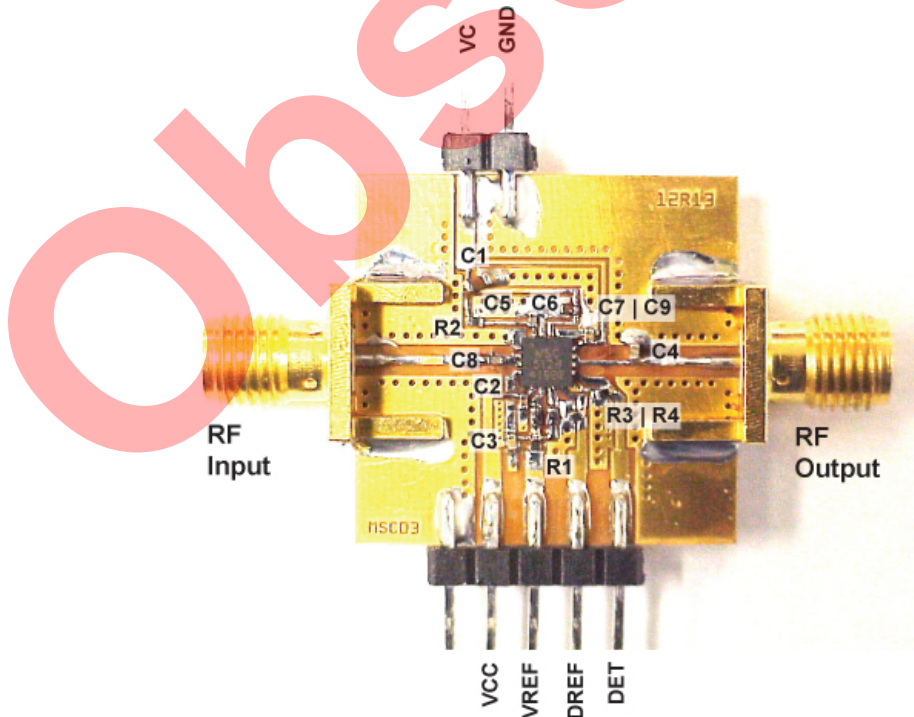
**EVALUATION BOARD**

(10 mil GETEK PCB, 0.9"x0.9", No Heat Sink)

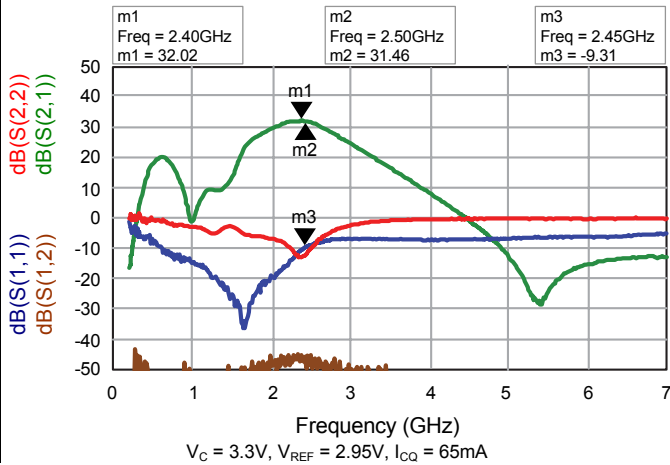
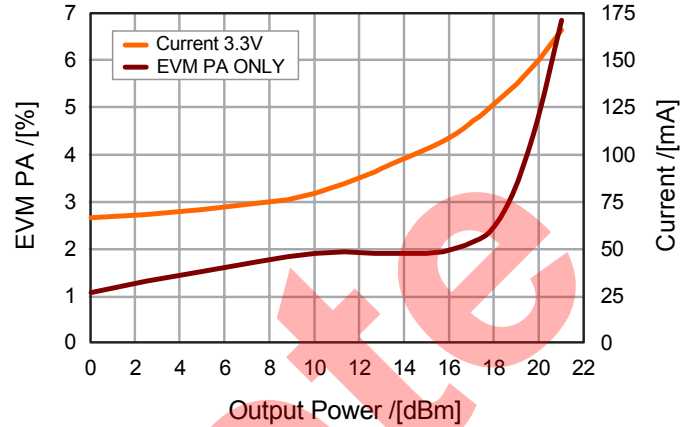
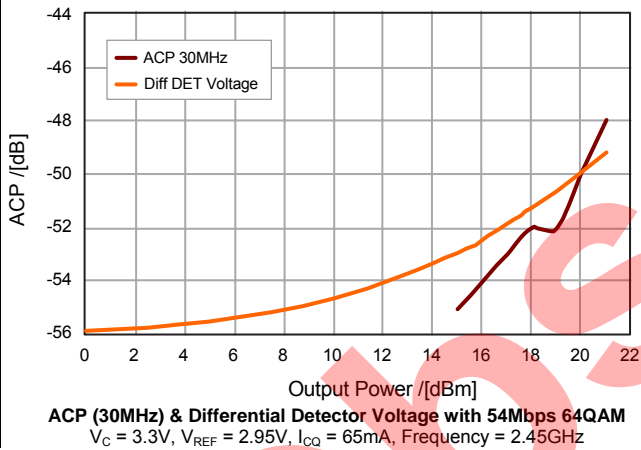
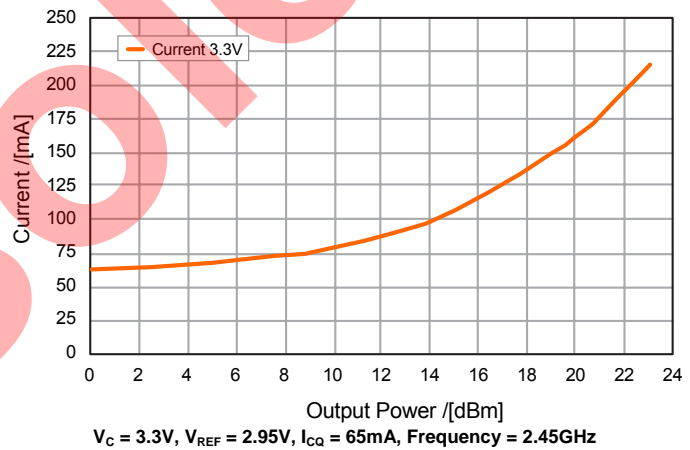
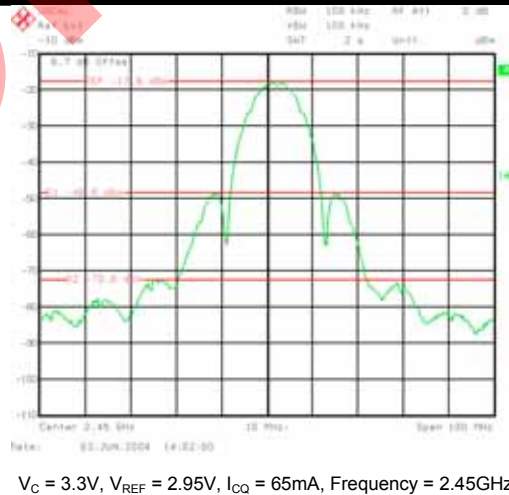
**S-PARAMETER DATA**

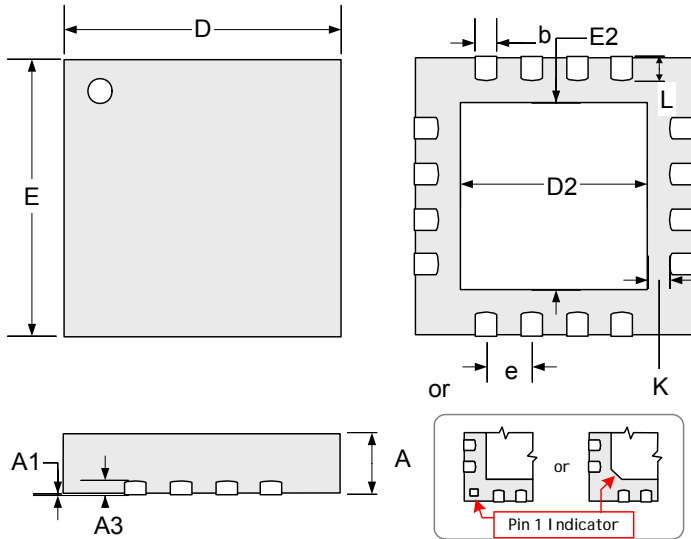
**EVM & SUPPLY CURRENT**

**ACP & DIFF DETECTOR VOLTAGE**

**CURRENT @ 11MBPS CCK**

**23DBM OUTPUT @ 11MBPS CCK**

**PACKAGE DIMENSIONS**
**LQ 16-Pin MLPQ 3x3**

Dim	MILLIMETERS		INCHES	
	MIN	MAX	MIN	MAX
A	0.80	1.00	0.031	0.039
A1	0	0.05	0	0.002
A3	0.20 REF		0.008 REF	
b	0.18	0.30	0.007	0.012
D	3.00 BSC		0.118 BSC	
E	3.00 BSC		0.118 BSC	
e	0.50 BSC		0.020 BSC	
D2	1.30	1.55	0.051	0.061
E2	1.30	1.55	0.051	0.061
K	0.2	-	0.008	-
L	0.35	0.50	0.012	0.020
L1	-	0.15	-	0.006

**Note:**

1. Dimensions do not include mold flash or protrusions; these shall not exceed 0.155mm(.006") on any side. Lead dimension shall not include solder coverage.
2. Due to multiple qualified assembly sub-contractors either package (with different pin one indicators) may be shipped. Package type will be consistent within the smallest individual container.



## TAPE AND REEL

### Tape And Reel Specification

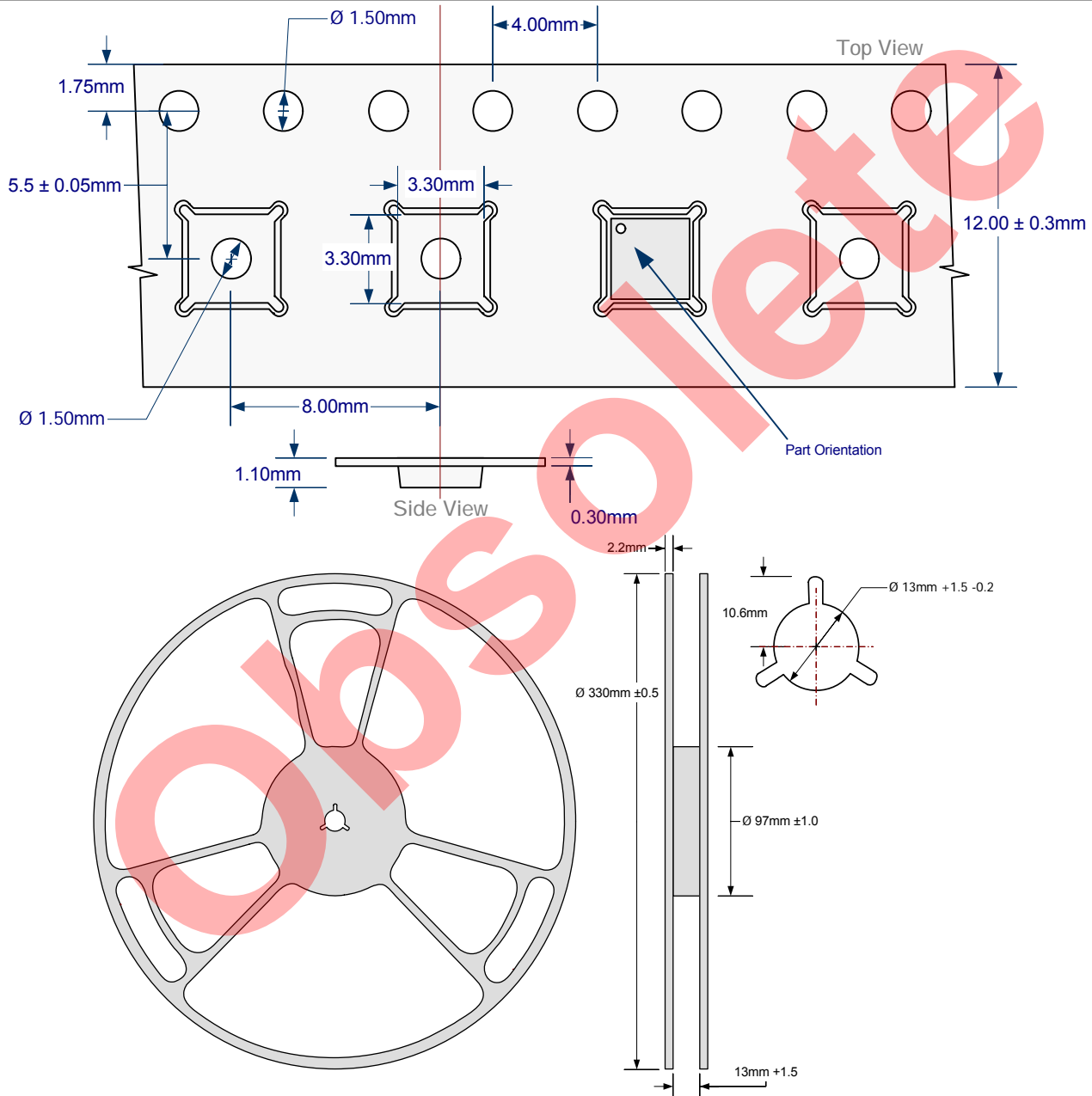



LX5512B

InGaP HBT 2.4 – 2.5 GHz Power Amplifier

PRODUCTION DATA SHEET

NOTES

Obsolete

PRODUCTION DATA – Information contained in this document is proprietary to Microsemi and is current as of publication date. This document may not be modified in any way without the express written consent of Microsemi. Product processing does not necessarily include testing of all parameters. Microsemi reserves the right to change the configuration and performance of the product and to discontinue product at any time.