

DUAL TANDEM ELECTRONIC POTENTIOMETER CIRCUIT

GENERAL DESCRIPTION

The TDA1074A is a monolithic integrated circuit designed for use as volume and tone control circuit in stereo amplifiers. This dual tandem potentiometer IC consists of two ganged pairs of electronic potentiometers with the eight inputs connected via impedance converters, and the four outputs driving individual operational amplifiers. The setting of each electronic potentiometer pair is controlled by an individual d.c. control voltage. The potentiometers operate by current division between the arms of cross-coupled long-tailed pairs. The current division factor is determined by the level and polarity of the d.c. control voltage with respect to an externally available reference level of half the supply voltage. Since the electronic potentiometers are adjusted by a d.c. control voltage, each pair can be controlled by single linear potentiometers which can be located in any position dictated by the equipment styling. Since the input and feedback impedances around the operational amplifier gain blocks are external, the TDA1074A can perform bass/treble and volume/loudness control. It also can be used as a low-level fader to control the sound distribution between the front and rear loudspeakers in car radio installations.

Features

- High impedance inputs to both 'ends' of each electronic potentiometer
- Ganged potentiometers track within 0,5 dB
- Electronic rejection of supply ripple
- Internally generated reference level available externally so that the control voltage can be made to swing positively and negatively around a well-defined 0 V level
- The operational amplifiers have push-pull outputs for wide voltage swing and low current consumption
- The operational amplifier outputs are current limited to provide output short-circuit protection
- Although designed to operate from a 20 V supply (giving a maximum input and output signal level of 6 V), the TDA1074A can work from a supply as low as 7,5 V with reduced input and output signal levels

QUICK REFERENCE DATA

Supply voltage (pin 11)	V_P	typ.	20 V
Supply current (pin 11)	I_P	typ.	22 mA
Input signal voltage (r.m.s. value)	$V_{i(rms)}$	max.	6 V
Output signal voltage (r.m.s. value)	$V_{o(rms)}$	max.	6 V
Total harmonic distortion	THD	typ.	0,05 %
Output noise voltage (r.m.s. value)	$V_{no(rms)}$	typ.	50 μ V
Control range	$\Delta\alpha$	typ.	110 dB
Cross-talk attenuation (L/R)	α_{ct}	typ.	80 dB
Ripple rejection (100 Hz)	α_{100}	typ.	46 dB
Tracking of ganged potentiometers	ΔG_V	typ.	0,5 dB
<hr/>			
Supply voltage range	V_P		7,5 to 23 V
Operating ambient temperature range	T_{amb}		-30 to + 80 $^{\circ}$ C

PACKAGE OUTLINE

18-lead DIL; plastic (SOT102).

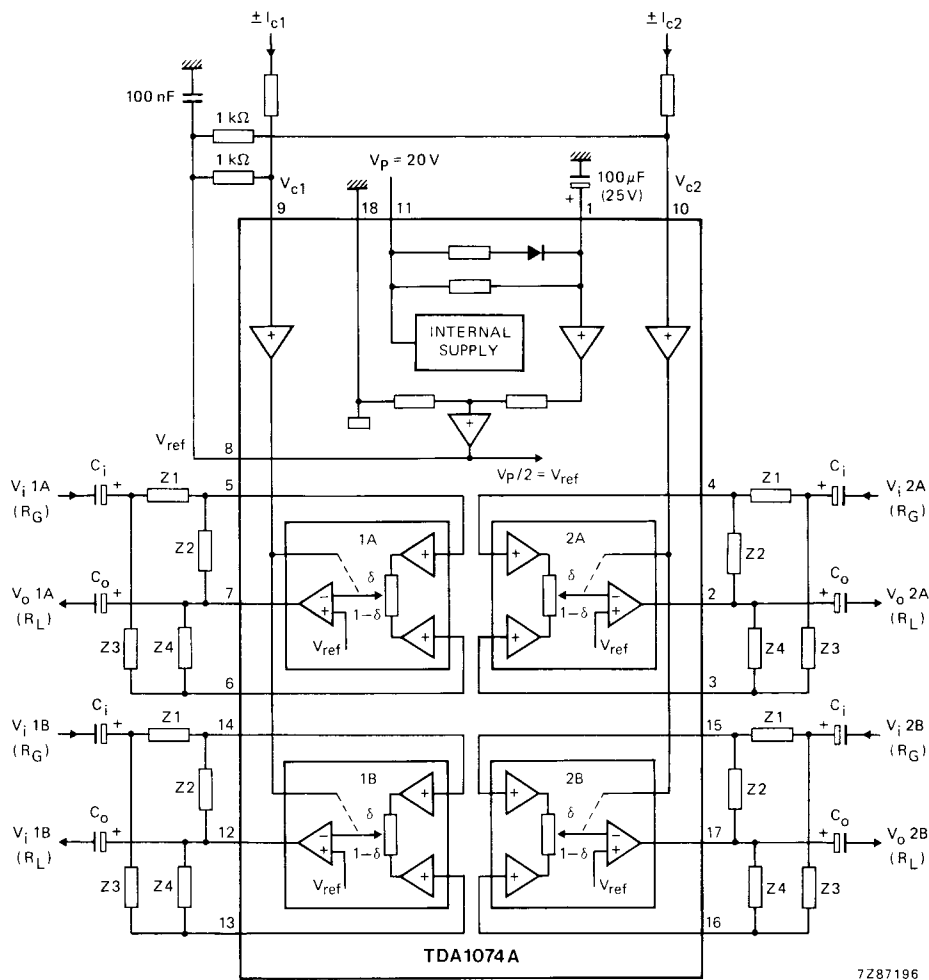

7Z87196

Fig. 1 Block diagram and basic external components; I_{c1} (at pin 9) and I_{c2} (at pin 10) are control input currents; V_{c1} (at pin 9) and V_{c2} (at pin 10) are control input voltages with respect to $V_{ref} = V_p/2$ at pin 8; $Z_1 = Z_2 = Z_3 = Z_4 = 22\text{ k}\Omega$; the input generator resistance $R_G = 60\ \Omega$; the output load resistance $R_L = 4,7\text{ k}\Omega$; the coupling capacitors at the inputs and outputs are $C_i = 2,2\ \mu\text{F}$ and $C_o = 10\ \mu\text{F}$ respectively.

RATINGS

Limiting values in accordance with the Absolute Maximum System (IEC 134)

Supply voltage (pin 11)	V_P	max.	23 V
Control voltages (pins 9 and 10)	$\pm V_{C1}; \pm V_{C2}$	max.	1 V
Input voltage ranges (with respect to pin 18) at pins 3, 4, 5, 6, 13, 14, 15, 16	V_i		0 to V_P V
Total power dissipation	P_{tot}	max.	800 mW
Storage temperature range	T_{stg}		-55 to +150 °C
Operating ambient temperature range	T_{amb}		-30 to +80 °C

THERMAL RESISTANCE

From crystal to ambient	$R_{th\ cr-a}$	=	80 K/W
-------------------------	----------------	---	--------

REMARK

The difference between the TDA1074 and its successor the TDA1074A is shown in Fig. 2 as the different component configuration at pin 8.

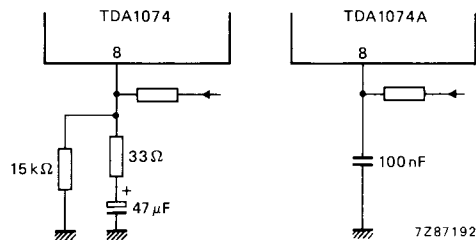

Fig. 2 Component configuration at pin 8 showing the difference between the TDA1074 and the TDA1074A.

APPLICATION INFORMATION

Treble and bass control circuit

$V_P = 20\text{ V}$; $T_{\text{amb}} = 25\text{ }^\circ\text{C}$; measured in Fig. 3; $R_G = 60\text{ }\Omega$; $R_L > 4,7\text{ k}\Omega$; $C_L < 30\text{ pF}$; $f = 1\text{ kHz}$; with a linear frequency response ($V_{C1} = V_{C2} = 0\text{ V}$); unless otherwise specified

parameter	symbol	min.	typ.	max.	unit
Supply current (without load)	I_p	14	22	30	mA
Frequency response (-1 dB) $V_{C1} = V_{C2} = 0\text{ V}$	f	10	—	20 000	Hz
Voltage gain at linear frequency response ($V_{C1} = V_{C2} = 0\text{ V}$)	G_V^*	—	0	—	dB
Gain variation at $f = 1\text{ kHz}$ at maximum bass/treble boost or cut at $\pm V_{C1} = \pm V_{C2} = 120\text{ mV}$	ΔG_V^*	—	± 1	—	dB
Bass boost at 40 Hz (ref. 1 kHz) $V_{C2} = 120\text{ mV}$		—	17,5	—	dB
Bass cut at 40 Hz (ref. 1 kHz) $-V_{C2} = 120\text{ mV}$		—	17,5	—	dB
Treble boost at 16 kHz (ref. 1 kHz) $V_{C1} = 120\text{ mV}$		—	16	—	dB
Treble cut at 16 kHz (ref. 1 kHz) $-V_{C1} = 120\text{ mV}$		—	16	—	dB
Total harmonic distortion at $V_{O(\text{rms})} = 300\text{ mV}$ $f = 1\text{ kHz}$ (measured selectively).	THD	—	0,002	—	%
$f = 20\text{ Hz}$ to 20 kHz	THD	—	0,005	—	%
at $V_{O(\text{rms})} = 5\text{ V}$ $f = 1\text{ kHz}$	THD	—	0,015	0,1	%
$f = 20\text{ Hz}$ to 20 kHz	THD	—	0,05	0,1	%
Signal level at THD = 0,7% (input and output)	$V_{i; o(\text{rms})}$	5,5	6,2	—	V
Power bandwidth at reference level $V_{O(\text{rms})} = 5\text{ V}$ (-3 dB); THD = 0,1%	B	—	40	—	kHz
Output noise voltages signal plus noise (r.m.s. value); $f = 20\text{ Hz}$ to 20 kHz	$V_{\text{no}(\text{rms})}$	—	75	—	μV
noise (peak value); weighted to DIN 45 405; CCITT filter	$V_{\text{no}(\text{m})}$	—	160	230	μV

* $G_V = V_O/V_i$.

Treble and bass control circuit

parameter	symbol	min.	typ.	max.	unit
Cross-talk attenuation (stereo)					
f = 1 kHz	α_{ct}	—	86	—	dB
f = 20 Hz to 20 kHz	α_{ct}	—	80	—	dB
Control voltage cross-talk to the outputs at f = 1 kHz;					
$V_{c1}(rms) = V_{c2}(rms) = 1$ mV	$-\alpha_{ct}$	—	20	—	dB
Ripple rejection at f = 100 Hz;					
$V_P(rms) < 200$ mV	α_{100}	—	46	—	dB

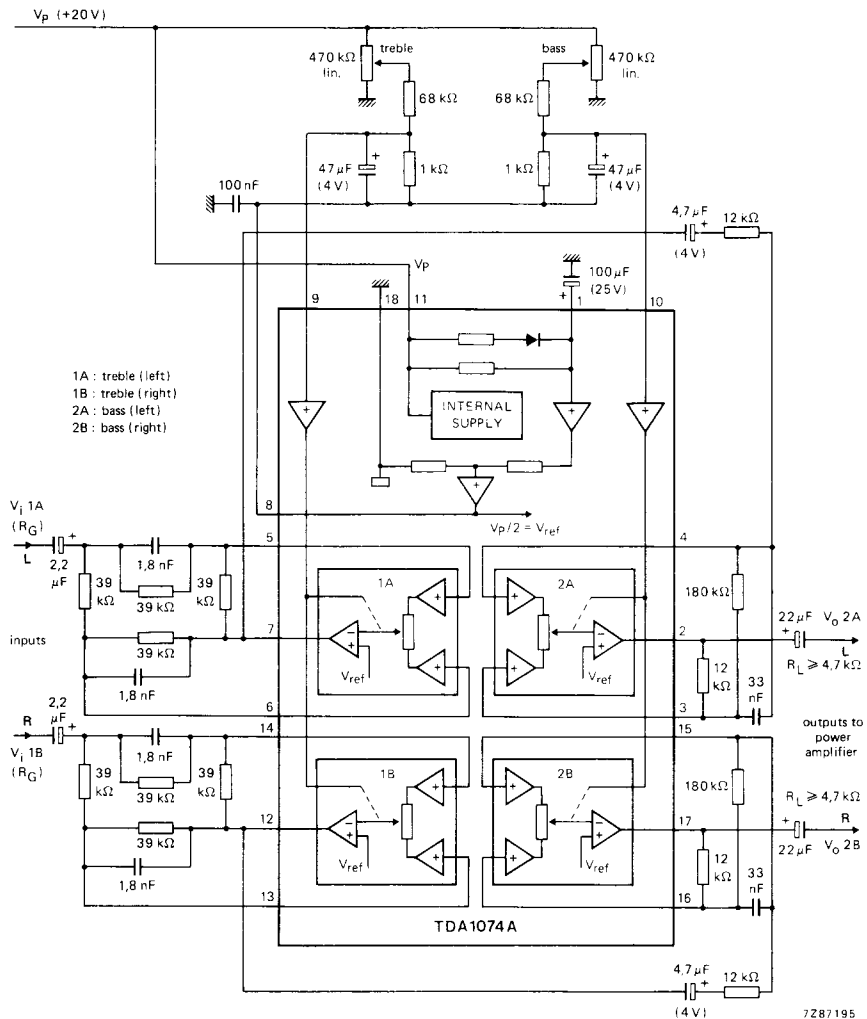

Fig. 3 Application diagram for treble and bass control.

APPLICATION INFORMATION (continued)

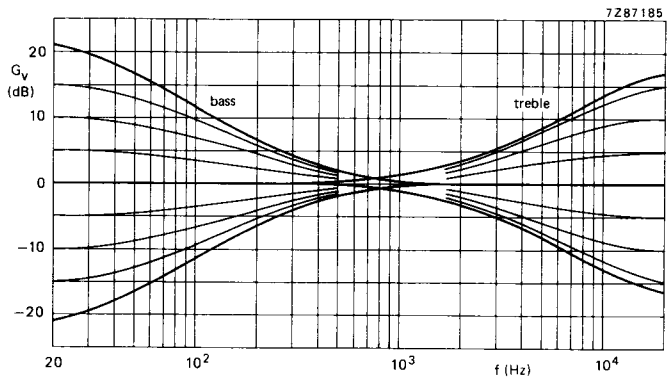

Fig. 4 Frequency response curves; voltage gain (treble and bass) as a function of frequency.

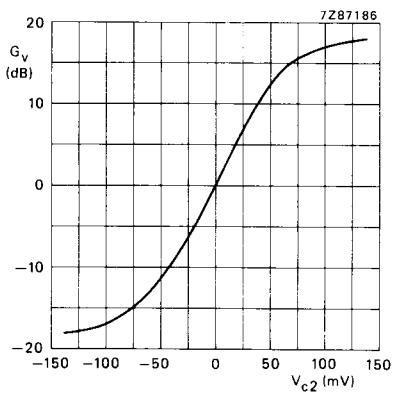

Fig. 5 Control curve; voltage gain (bass) as a function of the control voltage (V_{C2}); $f = 40$ Hz.

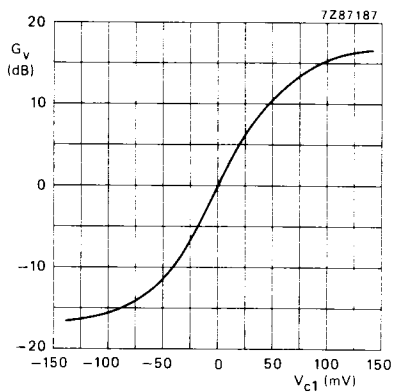
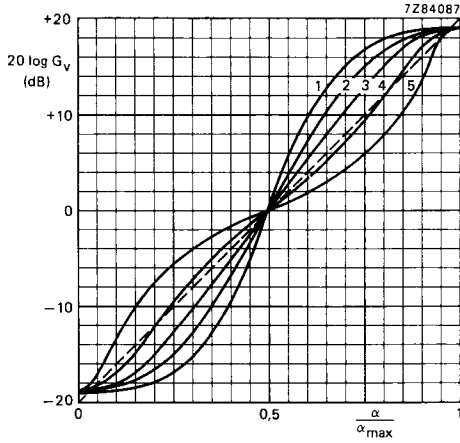

Fig. 6 Control curve; voltage gain (treble) as a function of the control voltage (V_{C1}); $f = 16$ kHz.



curve no.	value of R
1	10 kΩ
2	100 kΩ
3	220 kΩ
4	470 kΩ
5	1 MΩ

Fig. 7 Voltage gain ($G_V = V_O/V_i$) control curves as a function of the angle of rotation (α) of a linear potentiometer (R); for curve numbers see table above; $f = 40$ Hz to 16 kHz.

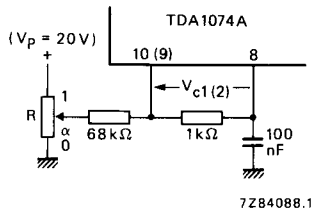

Fig. 8 Circuit diagram for measuring curves in Fig. 7.

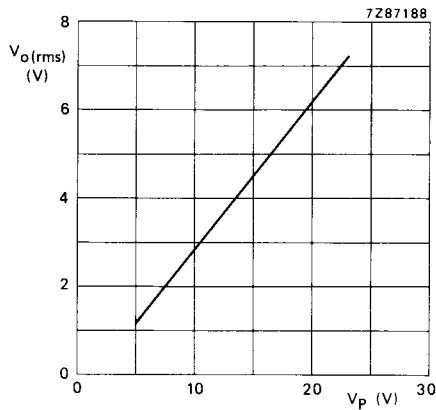

Fig. 9 Output signal level as a function of V_p ; THD = 0,7%; $f = 1$ kHz; $V_{c1} = V_{c2} = 0$ V.

APPLICATION INFORMATION (continued)

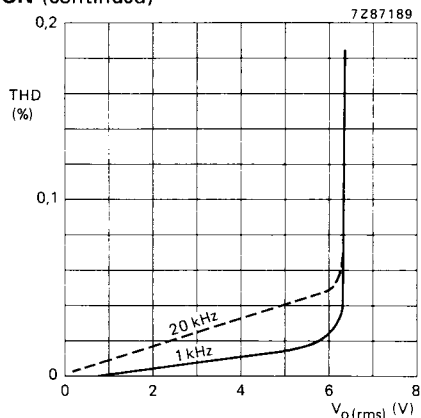

Fig. 10 Total harmonic distortion as a function of the output level; $V_P = 20$ V; $R_L = 4,7$ k Ω ; $V_{c1} = V_{c2} = 0$ V (linear, $G_{V\ tot} = 1$). — $f = 1$ kHz; - - - $f = 20$ kHz.

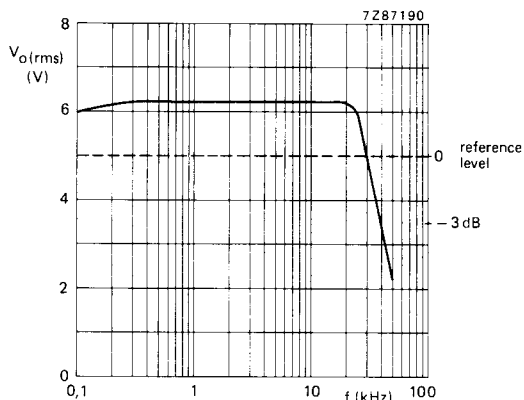

Fig. 11 Power bandwidth at THD = 0,1%; reference level is 5 V (r.m.s.).

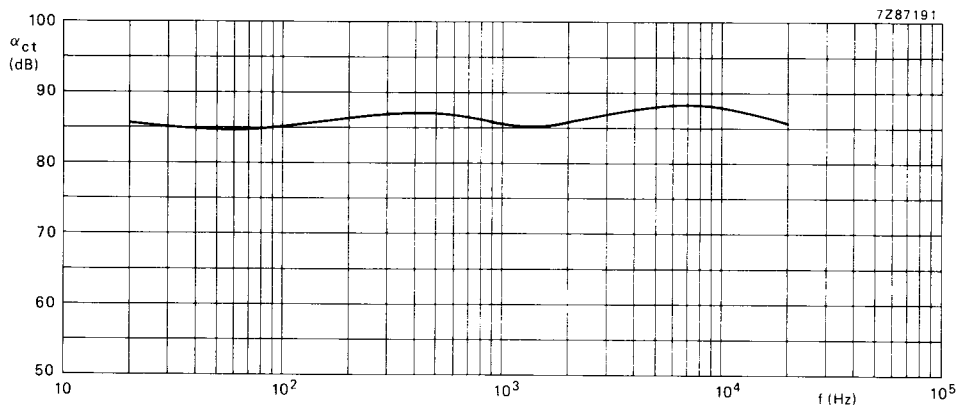
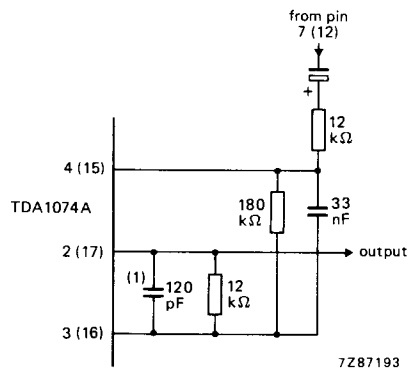

Fig. 12 Cross-talk as a function of frequency; linear treble/bass setting ($V_{c1} = V_{c2} = 0$ V); $V_i = 5$ V; $R_G = 60$ Ω ; $R_L = 4,7$ k Ω .

Application recommendations

1. If one or more electronic potentiometers in an IC are not used, the following is recommended:
 - a. Unused signal inputs of an electronic potentiometer should be connected to the associated output, e.g. pins 3 and 4 to pin 2.
 - b. Unused control voltage inputs should be connected directly to pin 8 (V_{ref}).
2. Where more than one TDA1074A IC are used in an application, pins 1 can be connected together; however, pins 8 (V_{ref}) may not be connected together directly.
3. Additional circuitry for limiting the frequency response in the ultrasonic range.



(1) $f_{-3\text{dB}} = 110\text{ kHz}$ at linear setting

Fig. 13 Circuit diagram for frequency response limiting.

4. Alternative circuitry for limiting the gain of the treble control circuit in the ultrasonic range.

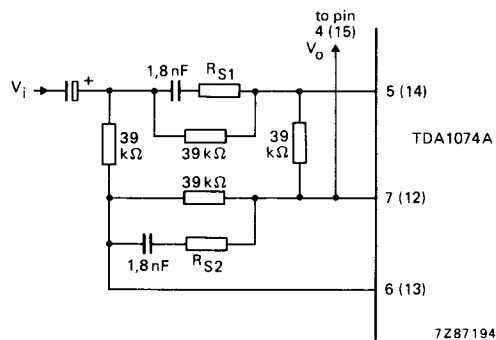

For $R_{S1} = R_{S2} = 3,3\text{ k}\Omega$; $f_{-3\text{dB}} \cong 1\text{ MHz}$ at linear setting

For $R_{S1} = R_{S2} = 0\ \Omega$; $f_{-3\text{dB}} \cong 100\text{ kHz}$ at linear setting

Fig. 14 Circuit diagram for limiting gain of treble control circuit.