

**QUAD OP AMP AND VOLTAGE REFERENCE****AP4302****General Description**

The AP4302 is a monolithic IC specifically designed to regulate the output current and voltage levels of switching battery chargers and power supplies.

The device contains quad Op Amps and a 2.5V externally adjusted voltage reference in a 16-pin package. The four Op Amps feature accurate voltage and current control. Combining a stable voltage reference with the four Op Amps makes AP4302 ideal for use in multi-function charger, power supply voltage monitor, signal processing and control system.

The IC offers the power converter designer a control solution that features increased precision with a corresponding reduction in system complexity and cost.

The AP4302 is available in standard packages of DIP-16 and SOIC-16.

Features**Op Amp**

- Input Offset Voltage: 0.5mV
- Supply Current: 250 μ A per Op Amp at 5.0V Supply Voltage
- Unity Gain Bandwidth: 1MHz
- Output Voltage Swing: 0 to ($V_{CC}-1.5$)V
- Power Supply Range: 3 to 18V

Voltage Reference

- Reference Voltage Tolerance: 0.5%, 1%
- Sink Current Capability from 0.1 to 80mA
- Output Dynamic Impedance: 0.2 Ω
- Externally Adjusted Voltage Reference: 2.5V

Applications

- Battery Charger
- Switching Power Supply
- Mother Board

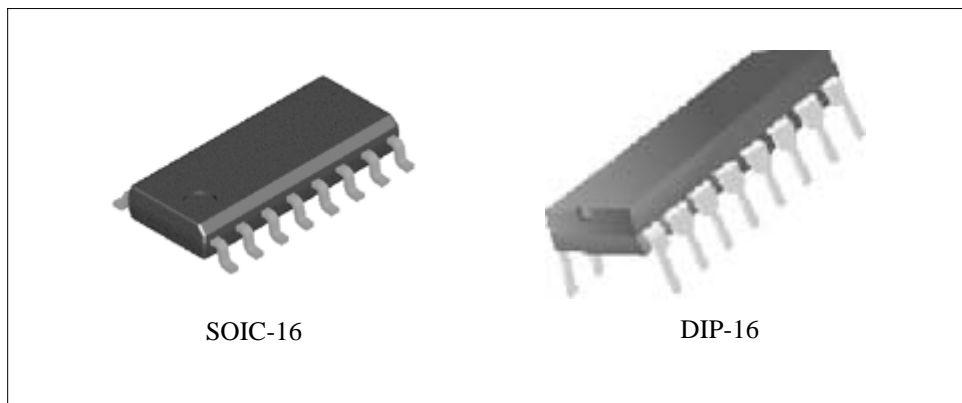

Figure 1. Package Types of AP4302



QUAD OP AMP AND VOLTAGE REFERENCE

AP4302

Pin Configuration

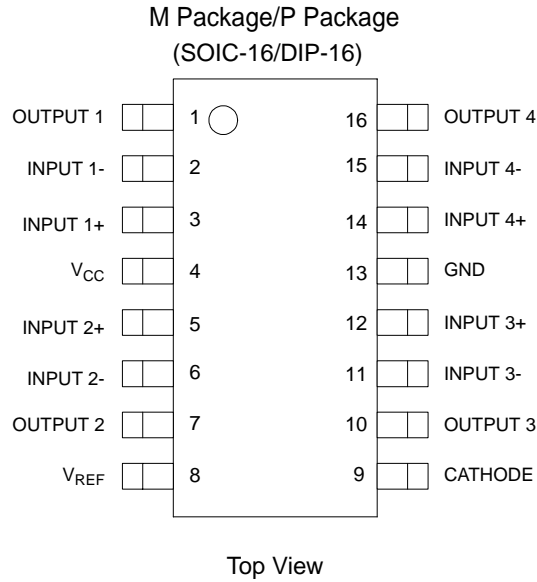

Figure 2. Pin configuration of AP4302

Functional Block Diagram

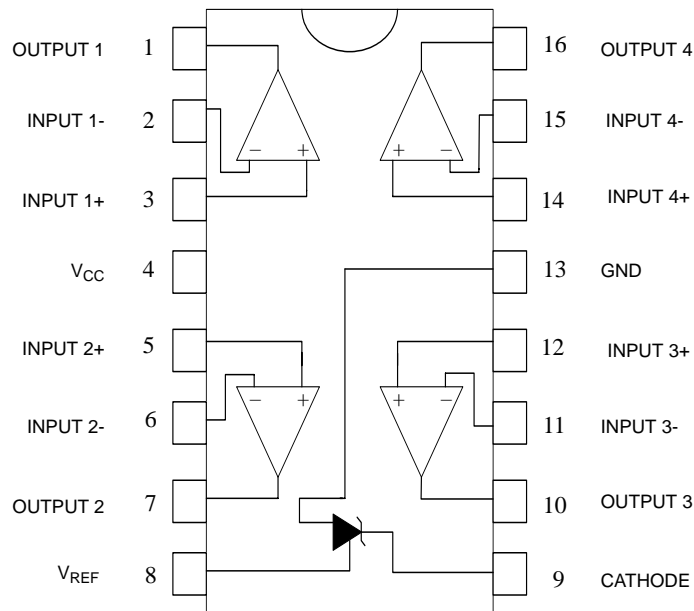

Figure 3. Functional Block Diagram of AP4302



QUAD OP AMP AND VOLTAGE REFERENCE

AP4302

Functional Block Diagram (Continued)

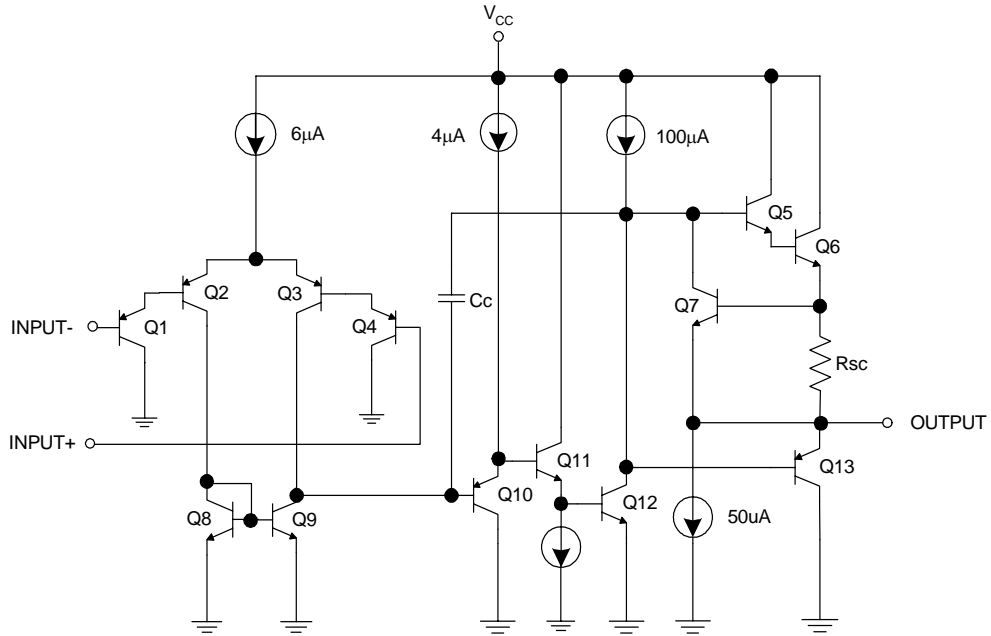

Figure 4. Op Amp Functional Block Diagram
(Each Amplifier)

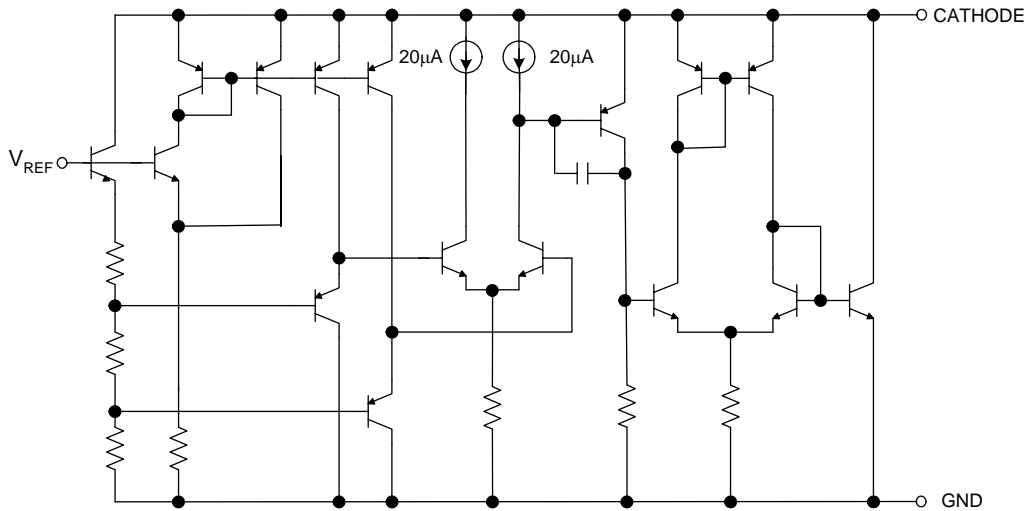
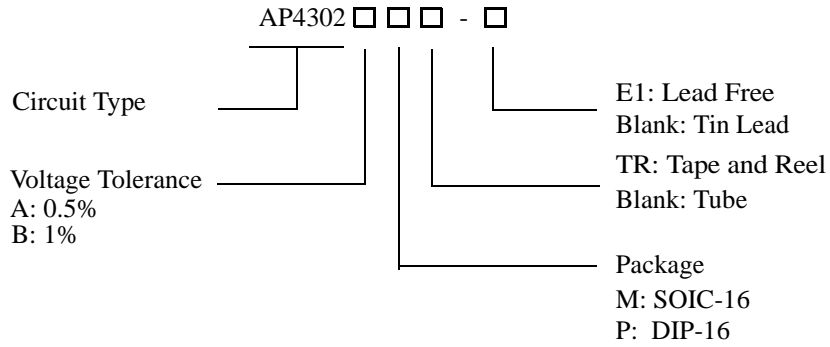

Figure 5. Voltage Reference Functional Block Diagram



QUAD OP AMP AND VOLTAGE REFERENCE AP4302

Ordering Information



Package	Voltage Tol-erance	Tempera-ture Range	Part Number		Marking ID		Packing Type
			Tin Lead	Lead Free	Tin Lead	Lead Free	
DIP-16	0.5%	-40 to 85°C	AP4302AP	AP4302AP-E1	AP4302AP	AP4302AP-E1	Tube
	1%		AP4302BP	AP4302BP-E1	AP4302BP	AP4302BP-E1	
SOIC-16	0.5%	-40 to 85°C	AP4302AM	AP4302AM-E1	AP4302AM	AP4302AM-E1	Tube
			AP4302AMTR	AP4302AMTR-E1	AP4302AM	AP4302AM-E1	Tape & Reel
	1%		AP4302BM	AP4302BM-E1	AP4302BM	AP4302BM-E1	Tube
			AP4302BMTR	AP4302BMTR-E1	AP4302BM	AP4302BM-E1	Tape & Reel

BCD Semiconductor's Pb-free products, as designated with "E1" suffix in the part number, are RoHS compliant.

**QUAD OP AMP AND VOLTAGE REFERENCE****AP4302****Absolute Maximum Ratings (Note 1)**

Parameter	Symbol	Value	Unit	
Power Supply Voltage (V_{CC} to GND)	V_{CC}	20	V	
Input Voltage Range	V_{IN}	-0.3 to $V_{CC}+0.3$	V	
Op Amp Input Differential Voltage	V_{ID}	20	V	
Voltage Reference Cathode Current	I_K	100	mA	
Power Dissipation ($T_A=25^\circ\text{C}$)	P_D	DIP-16	1000	mW
		SOIC-16	850	
Operating Junction Temperature	T_J	150	$^\circ\text{C}$	
Storage Temperature Range	T_{STG}	-65 to 150	$^\circ\text{C}$	
Lead Temperature (Soldering 10s)	T_L	260	$^\circ\text{C}$	

Note 1: Stresses greater than those listed under "Absolute Maximum Ratings" may cause permanent damage to the device. These are stress ratings only, and functional operation of the device at these or any other conditions beyond those indicated under "Recommended Operating Conditions" is not implied. Exposure to "Absolute Maximum Ratings" for extended periods may affect device reliability.

Recommended Operating Conditions

Parameter	Min	Max	Unit
Supply Voltage	3	18	V
Ambient Temperature	-40	85	$^\circ\text{C}$



QUAD OP AMP AND VOLTAGE REFERENCE

AP4302

Electrical Characteristics

Operating Conditions: $V_{CC}=+5V$, $T_A=25^{\circ}C$ unless otherwise specified.

Parameter	Conditions	Min	Typ	Max	Unit	
Total Supply Current, Excluding Current in Voltage Reference	$V_{CC}=5V$, no load, $-40^{\circ}C \leq T_A \leq 85^{\circ}C$		1.0	1.6	mA	
	$V_{CC}=18V$, no load, $-40^{\circ}C \leq T_A \leq 85^{\circ}C$		1.2	2.4		
Voltage Reference Section						
Reference Voltage	$I_{KA}=10mA$ $T_A=25^{\circ}C$	0.5% tolerance	2.487	2.500	2.513	V
		1% tolerance	2.475			
Reference Voltage Deviation over Full Temperature Range	$I_{KA}=10mA$, $T_A=-40$ to $85^{\circ}C$		5	24	mV	
Minimum Cathode Current for Regulation			0.1	0.2	mA	
Ratio of Change in V_{REF} to that of Cathode Voltage	$I_{KA}=10mA$	V_{REF} to 10V		1.0	2.7	mV/V
		10V to 18V		0.5	2.0	
Reference Current	$I_{KA}=10mA$, $R1=10K$, $R2=\infty$		0.7	4	μA	
The Deviation of Reference Current over Temperature	$V_{KA}=V_{REF}$, $I_{KA}=10mA$, $T_A=-40$ to $85^{\circ}C$		0.4	1.2	μA	
Off-State Cathode Current	$V_{REF}=0$, $V_{KA}=18V$		0.05	1.0	μA	
Dynamic Impedance	$I_{KA}=1.0$ to $80mA$, $f < 1kHz$		0.2	0.5	Ω	



QUAD OP AMP AND VOLTAGE REFERENCE

AP4302

Electrical Characteristics (Continued)

Operating Conditions: $V_{CC}=+5V$, $T_A=25^{\circ}C$ unless otherwise specified.

Parameter	Conditions	Min	Typ	Max	Unit
Op Amp Section (per Op Amp) ($V_{CC}=5V$, $V_O=1.4V$, $T_A=25^{\circ}C$, unless otherwise noted)					
Input Offset Voltage	$T_A=25^{\circ}C$		0.5	3	mV
	$T_A=-40$ to $85^{\circ}C$			5	
Input Offset Voltage Temperature Drift	$T_A=-40$ to $85^{\circ}C$		7		$\mu V/^{\circ}C$
Input Offset Current	$T_A=25^{\circ}C$		2	30	nA
Input Bias Current	$T_A=25^{\circ}C$		20	150	nA
Input Voltage Range	$V_{CC}=0$ to $18V$	0		$V_{CC}-1.5$	V
Common Mode Rejection Ratio	$T_A=25^{\circ}C$, $V_{CM}=0$ to $3.5V$	70	85		dB
Large Signal Voltage Gain	$V_{CC}=15V$, $R_L=2k\Omega$, $V_O=1.4$ to $11.4V$	85	100		dB
Power Supply Rejection Ratio	$V_{CC}=5$ to $18V$	70	90		dB
Output Current	Source	$V_{CC}=15V$, $V_{ID}=1V$, $V_O=2V$	20	40	mA
	Sink	$V_{CC}=15V$, $V_{ID}=-1V$, $V_O=2V$	10	20	mA
Output Voltage Swing (High)	$V_{CC}=18V$, $R_L=10k\Omega$, $V_{ID}=1V$	16	16.5		V
Output Voltage Swing (Low)	$V_{CC}=18V$, $R_L=10k\Omega$, $V_{ID}=-1V$		17	100	mV
Slew Rate	$V_{CC}=18V$, $R_L=2k\Omega$, $A_V=1$, $V_{IN}=0.5$ to $2V$, $C_L=100pF$	0.3	0.5		$V/\mu s$
Gain Bandwidth Product	$V_{CC}=18V$, $R_L=2k\Omega$, $C_L=100pF$, $V_{IN}=10mV$, $f=100kHz$	0.7	1		MHz



QUAD OP AMP AND VOLTAGE REFERENCE

AP4302

Typical Performance Characteristics

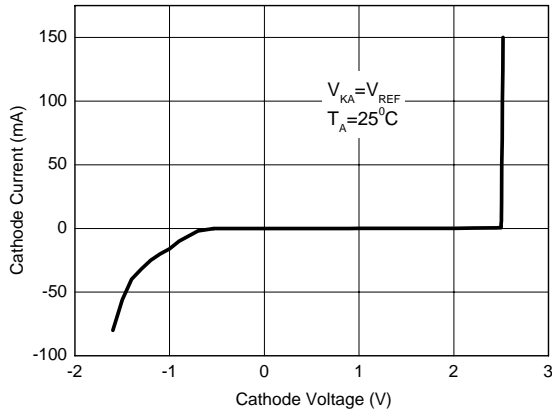

Figure 6. Cathode Current vs. Cathode Voltage

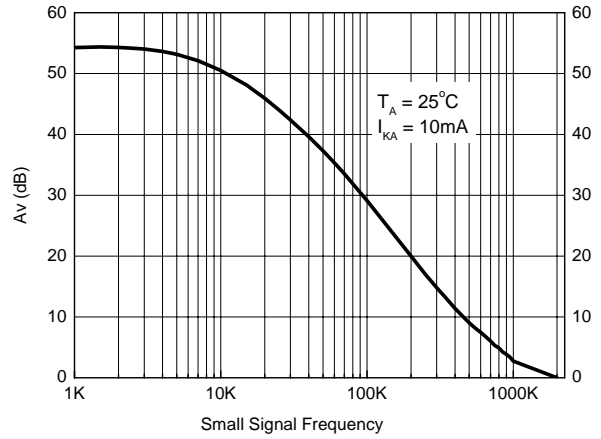

Figure 7. Voltage Reference Small Signal vs. Frequency

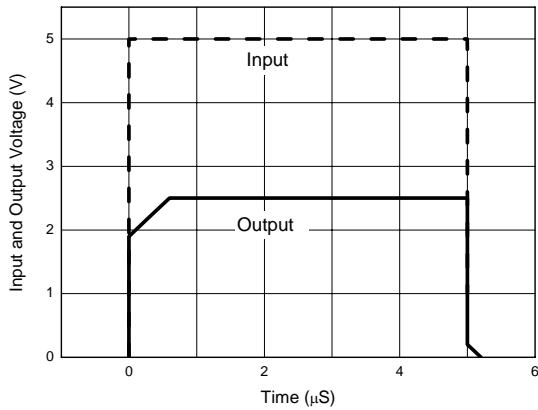

Figure 8. Pulse Response of Input and Output Voltage

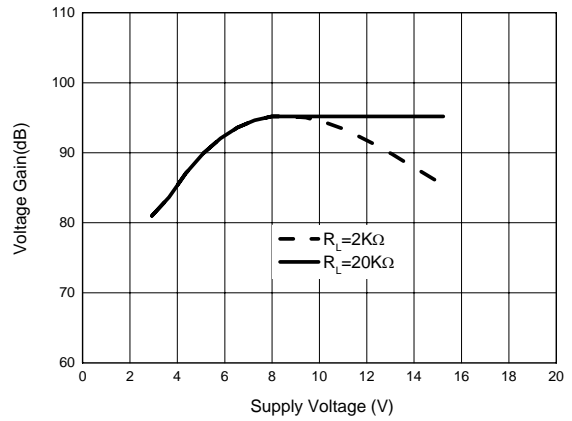

Figure 9. Op Amp Voltage Gain



QUAD OP AMP AND VOLTAGE REFERENCE

AP4302

Typical Performance Characteristics (Continued)

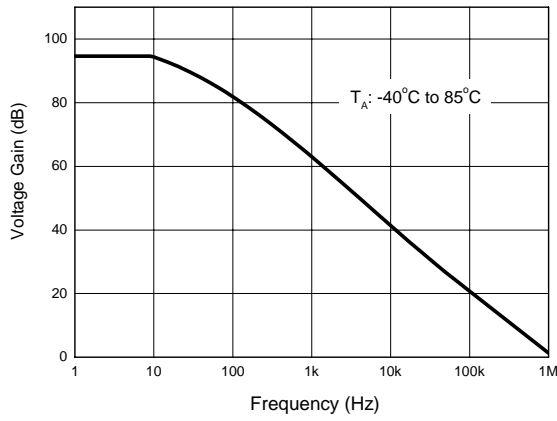

Figure 10. Op Amp Open Loop Frequency Response

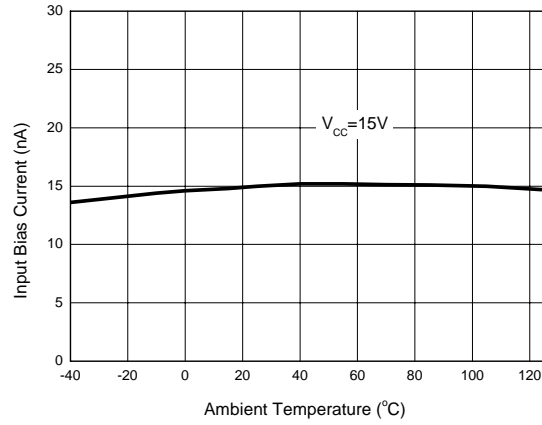

Figure 11. Op Amp Input Current

Typical Application

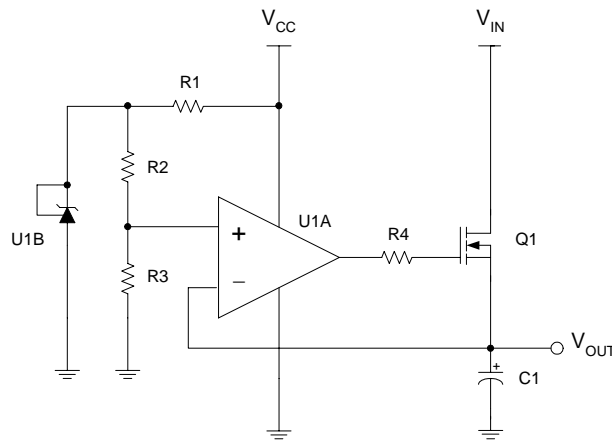

Figure 12. Use AP4302 Internal Parts to Build a Linear Regulator



QUAD OP AMP AND VOLTAGE REFERENCE

AP4302

Mechanical Dimensions

DIP-16

Unit: mm(inch)

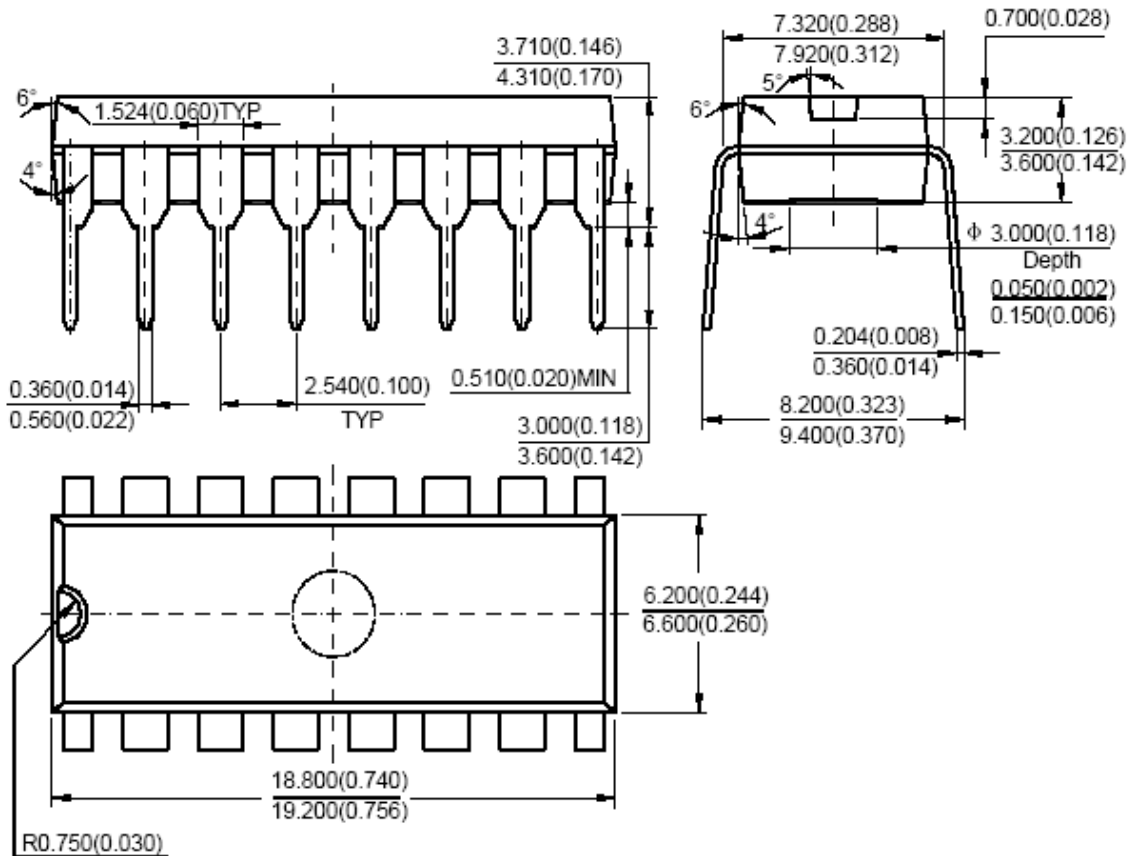



QUAD OP AMP AND VOLTAGE REFERENCE

AP4302

Mechanical Dimensions (Continued)

SOIC-16

Unit: mm(inch)

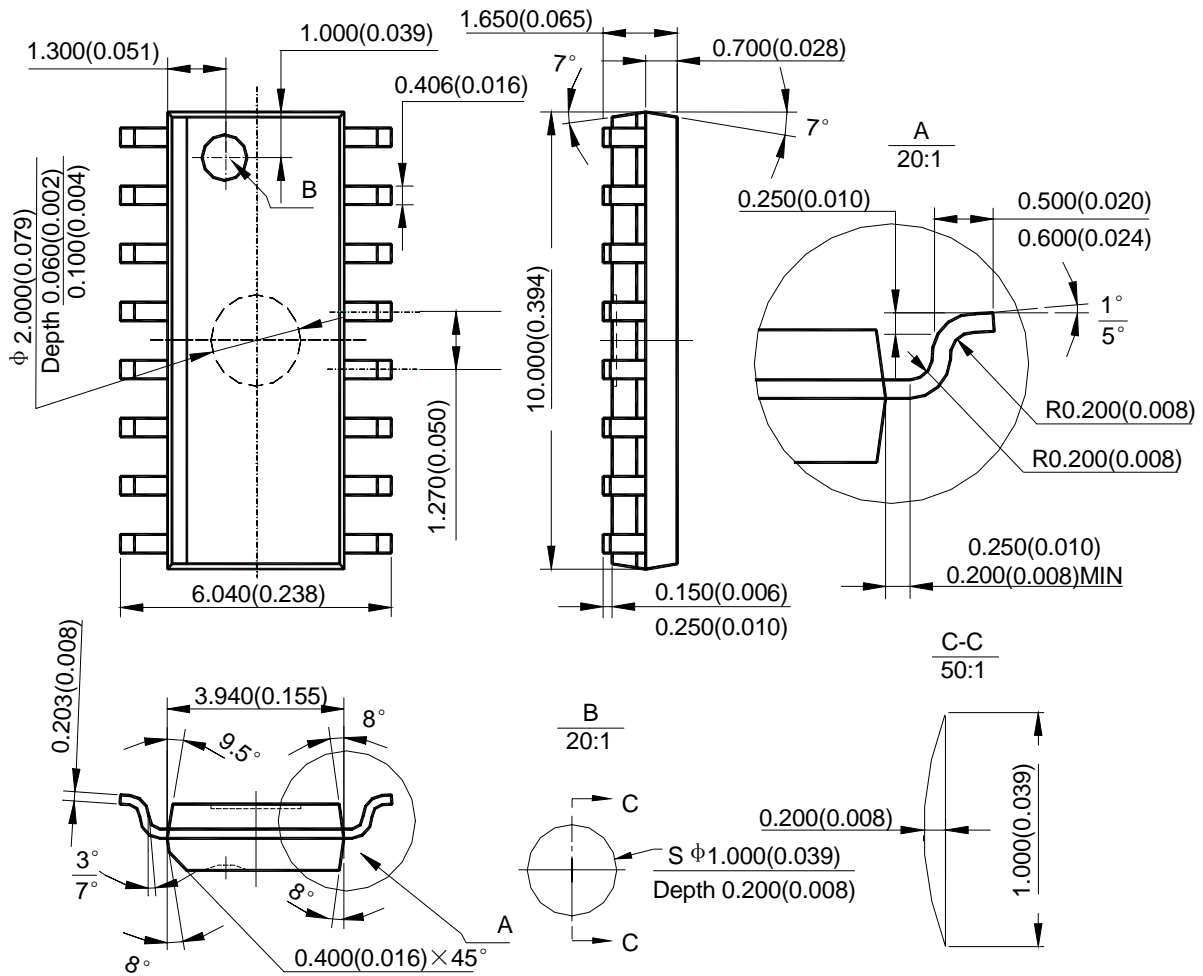



BCD Semiconductor Manufacturing Limited

<http://www.bcdsemi.com>

IMPORTANT NOTICE

BCD Semiconductor Manufacturing Limited reserves the right to make changes without further notice to any products or specifications herein. BCD Semiconductor Manufacturing Limited does not assume any responsibility for use of any its products for any particular purpose, nor does BCD Semiconductor Manufacturing Limited assume any liability arising out of the application or use of any its products or circuits. BCD Semiconductor Manufacturing Limited does not convey any license under its patent rights or other rights nor the rights of others.

MAIN SITE

BCD Semiconductor Manufacturing Limited
- Wafer Fab
Shanghai SIM-BCD Semiconductor Manufacturing Limited
800, Yi Shan Road, Shanghai 200233, China
Tel: +86-21-6485 1491, Fax: +86-21-5450 0008

BCD Semiconductor Manufacturing Limited
- IC Design Group
Advanced Analog Circuits (Shanghai) Corporation
8F, Zone B, 900, Yi Shan Road, Shanghai 200233, China
Tel: +86-21-6495 9539, Fax: +86-21-6485 9673

REGIONAL SALES OFFICE

Shenzhen Office
Shanghai SIM-BCD Semiconductor Manufacturing Co., Ltd. Shenzhen Office
Advanced Analog Circuits (Shanghai) Corporation Shenzhen Office
Room E, 5F, Noble Center, No.1006, 3rd Fuzhong Road, Futian District, Shenzhen 518026, China
Tel: +86-755-8826 7951
Fax: +86-755-8826 7865

Taiwan Office
BCD Semiconductor (Taiwan) Company Limited
4F, 298-1, Rui Guang Road, Nei-Hu District, Taipei, Taiwan
Tel: +886-2-2656 2808
Fax: +886-2-2656 2806

USA Office
BCD Semiconductor Corporation
30920 Huntwood Ave. Hayward, CA 94544, U.S.A
Tel : +1-510-324-2988
Fax: +1-510-324-2788