

To our customers,

---

## Old Company Name in Catalogs and Other Documents

---

On April 1<sup>st</sup>, 2010, NEC Electronics Corporation merged with Renesas Technology Corporation, and Renesas Electronics Corporation took over all the business of both companies. Therefore, although the old company name remains in this document, it is a valid Renesas Electronics document. We appreciate your understanding.

Renesas Electronics website: <http://www.renesas.com>

April 1<sup>st</sup>, 2010  
Renesas Electronics Corporation

Issued by: Renesas Electronics Corporation (<http://www.renesas.com>)

Send any inquiries to <http://www.renesas.com/inquiry>.

## Notice

1. All information included in this document is current as of the date this document is issued. Such information, however, is subject to change without any prior notice. Before purchasing or using any Renesas Electronics products listed herein, please confirm the latest product information with a Renesas Electronics sales office. Also, please pay regular and careful attention to additional and different information to be disclosed by Renesas Electronics such as that disclosed through our website.
2. Renesas Electronics does not assume any liability for infringement of patents, copyrights, or other intellectual property rights of third parties by or arising from the use of Renesas Electronics products or technical information described in this document. No license, express, implied or otherwise, is granted hereby under any patents, copyrights or other intellectual property rights of Renesas Electronics or others.
3. You should not alter, modify, copy, or otherwise misappropriate any Renesas Electronics product, whether in whole or in part.
4. Descriptions of circuits, software and other related information in this document are provided only to illustrate the operation of semiconductor products and application examples. You are fully responsible for the incorporation of these circuits, software, and information in the design of your equipment. Renesas Electronics assumes no responsibility for any losses incurred by you or third parties arising from the use of these circuits, software, or information.
5. When exporting the products or technology described in this document, you should comply with the applicable export control laws and regulations and follow the procedures required by such laws and regulations. You should not use Renesas Electronics products or the technology described in this document for any purpose relating to military applications or use by the military, including but not limited to the development of weapons of mass destruction. Renesas Electronics products and technology may not be used for or incorporated into any products or systems whose manufacture, use, or sale is prohibited under any applicable domestic or foreign laws or regulations.
6. Renesas Electronics has used reasonable care in preparing the information included in this document, but Renesas Electronics does not warrant that such information is error free. Renesas Electronics assumes no liability whatsoever for any damages incurred by you resulting from errors in or omissions from the information included herein.
7. Renesas Electronics products are classified according to the following three quality grades: “Standard”, “High Quality”, and “Specific”. The recommended applications for each Renesas Electronics product depends on the product’s quality grade, as indicated below. You must check the quality grade of each Renesas Electronics product before using it in a particular application. You may not use any Renesas Electronics product for any application categorized as “Specific” without the prior written consent of Renesas Electronics. Further, you may not use any Renesas Electronics product for any application for which it is not intended without the prior written consent of Renesas Electronics. Renesas Electronics shall not be in any way liable for any damages or losses incurred by you or third parties arising from the use of any Renesas Electronics product for an application categorized as “Specific” or for which the product is not intended where you have failed to obtain the prior written consent of Renesas Electronics. The quality grade of each Renesas Electronics product is “Standard” unless otherwise expressly specified in a Renesas Electronics data sheets or data books, etc.
  - “Standard”: Computers; office equipment; communications equipment; test and measurement equipment; audio and visual equipment; home electronic appliances; machine tools; personal electronic equipment; and industrial robots.
  - “High Quality”: Transportation equipment (automobiles, trains, ships, etc.); traffic control systems; anti-disaster systems; anti-crime systems; safety equipment; and medical equipment not specifically designed for life support.
  - “Specific”: Aircraft; aerospace equipment; submersible repeaters; nuclear reactor control systems; medical equipment or systems for life support (e.g. artificial life support devices or systems), surgical implantations, or healthcare intervention (e.g. excision, etc.), and any other applications or purposes that pose a direct threat to human life.
8. You should use the Renesas Electronics products described in this document within the range specified by Renesas Electronics, especially with respect to the maximum rating, operating supply voltage range, movement power voltage range, heat radiation characteristics, installation and other product characteristics. Renesas Electronics shall have no liability for malfunctions or damages arising out of the use of Renesas Electronics products beyond such specified ranges.
9. Although Renesas Electronics endeavors to improve the quality and reliability of its products, semiconductor products have specific characteristics such as the occurrence of failure at a certain rate and malfunctions under certain use conditions. Further, Renesas Electronics products are not subject to radiation resistance design. Please be sure to implement safety measures to guard them against the possibility of physical injury, and injury or damage caused by fire in the event of the failure of a Renesas Electronics product, such as safety design for hardware and software including but not limited to redundancy, fire control and malfunction prevention, appropriate treatment for aging degradation or any other appropriate measures. Because the evaluation of microcomputer software alone is very difficult, please evaluate the safety of the final products or system manufactured by you.
10. Please contact a Renesas Electronics sales office for details as to environmental matters such as the environmental compatibility of each Renesas Electronics product. Please use Renesas Electronics products in compliance with all applicable laws and regulations that regulate the inclusion or use of controlled substances, including without limitation, the EU RoHS Directive. Renesas Electronics assumes no liability for damages or losses occurring as a result of your noncompliance with applicable laws and regulations.
11. This document may not be reproduced or duplicated, in any form, in whole or in part, without prior written consent of Renesas Electronics.
12. Please contact a Renesas Electronics sales office if you have any questions regarding the information contained in this document or Renesas Electronics products, or if you have any other inquiries.

(Note 1) “Renesas Electronics” as used in this document means Renesas Electronics Corporation and also includes its majority-owned subsidiaries.

(Note 2) “Renesas Electronics product(s)” means any product developed or manufactured by or for Renesas Electronics.

## MICROSTEP DRIVER FOR DRIVING CAMERA LENS

### DESCRIPTION

The μPD168110 is a monolithic 2-channel H bridge driver that consists of a CMOS controller and a MOS output stage. It can reduce the current consumption and the voltage loss at the output stage compared with a conventional driver using bipolar transistors, thanks to employment of a MOS process. This product employs a P-channel MOSFET on the high side of the output stage, eliminating a charge pump. As a result, the circuit current consumption can be substantially reduced during operation.

This product is ideal for driving the motor of a digital still camera as it can switch over between two-phase excitation driving and microstep driving, using a stepper motor.

### FEATURES

- Two H bridge circuits employing power MOSFET
- Current feedback 64-step microstep driving and two-phase excitation driving selectable
- Low on-resistance: 2 Ω MAX.
- 3 V power supply
  - Minimum operating power supply voltage  $V_{DD} = 2.7 V$
- Under voltage lockout circuit
  - Shuts down internal circuitry at  $V_{DD} = 1.7 V$  TYP.
- 24-pin TSSOP

### ORDERING INFORMATION

Part Number	Package
μPD168110MA-6A5	24-pin plastic TSSOP (5.72 mm (225))

The information in this document is subject to change without notice. Before using this document, please confirm that this is the latest version.

Not all products and/or types are available in every country. Please check with an NEC Electronics sales representative for availability and additional information.

**PIN FUNCTIONS**

Package: 24-pin TSSOP

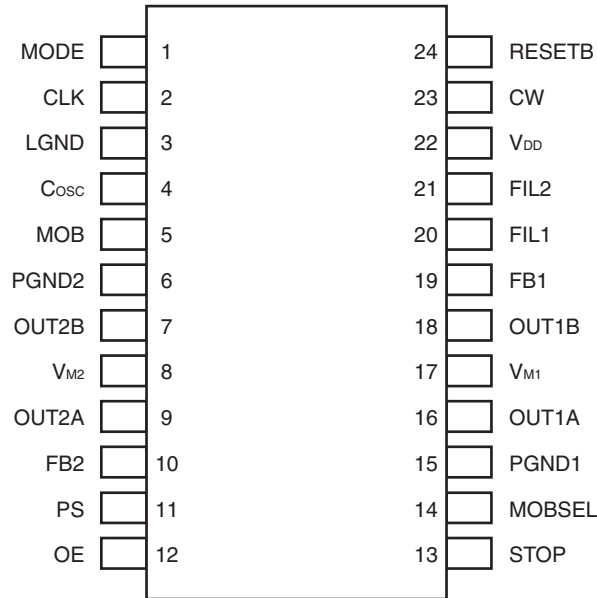

Pin No.	Pin Name	Pin Function
1	MODE	Microstep/2-phase excitation switch pin
2	CLK	Pulse input pin
3	LGND	Control block GND pin
4	C <sub>osc</sub>	Pin connecting capacitor for output oscillator
5	MOB	Phase detection output pin
6	PGND2	Output block GND pin
7	OUT2B	Channel 2 output B
8	V <sub>M2</sub>	Motor power pin
9	OUT2A	Channel 2 output A
10	FB2	Channel 2 current detection resistor connecting pin
11	PS	Power save mode pin
12	OE	Output enable pin
13	STOP	Stop mode pin
14	MOBSEL	MOB output select pin
15	PGND1	Output block GND pin
16	OUT1A	Channel 1 output A
17	V <sub>M1</sub>	Motor power pin
18	OUT1B	Channel 1 output B
19	FB1	Channel 1 current detection resistor connecting pin
20	FIL1	Channel 1 filter capacitor connecting pin
21	FIL2	Channel 2 filter capacitor connecting pin
22	V <sub>DD</sub>	Control block power pin
23	CW	Revolution direction setting pin
24	RESETB	Reset input pin

**BLOCK DIAGRAM**

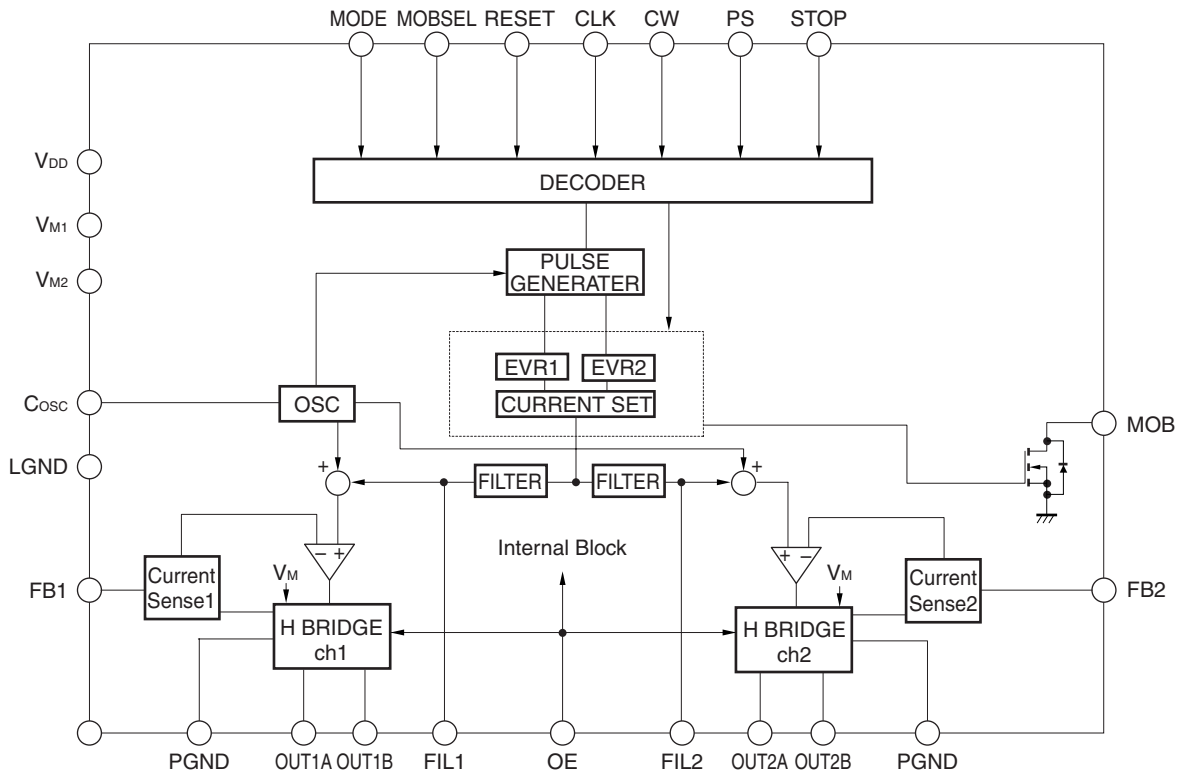

**Truth Table**

RESET	CLK	CW	OE	PS	STOP	MODE	MOBSSEL	Operation Mode
H		L	H	L	L	H	L	Microstep CW mode MOB: 1 pulse/cycle
H		H	H	L	L	H	L	Microstep CCW mode MOB: 1 pulse/cycle
H		L	H	L	L	H	H	Microstep CW mode MOB: 4 pulses/cycle
H		H	H	L	L	H	H	Microstep CCW mode MOB: 4 pulses/cycle
H		L	H	L	L	L	X	2-phase CW mode
H		H	H	L	L	L	X	2-phase CCW mode
H	X	X	L	X	X	X	X	Output Hi-Z
H	X	X	H	L	H	H	X	STOP mode after MOB = L (CLK must be input until MOB = L)
H	X	X	H	H	H	H	X	PS mode after MOB = L (CLK must be input until MOB = L)
H	X	X	H	H	L	H	X	Setting prohibited
L	X	X	X	X	X	X	X	Reset mode

H: High level, L: Low level, X: High level or low level

**Command Input Timing Chart**

In microstep mode

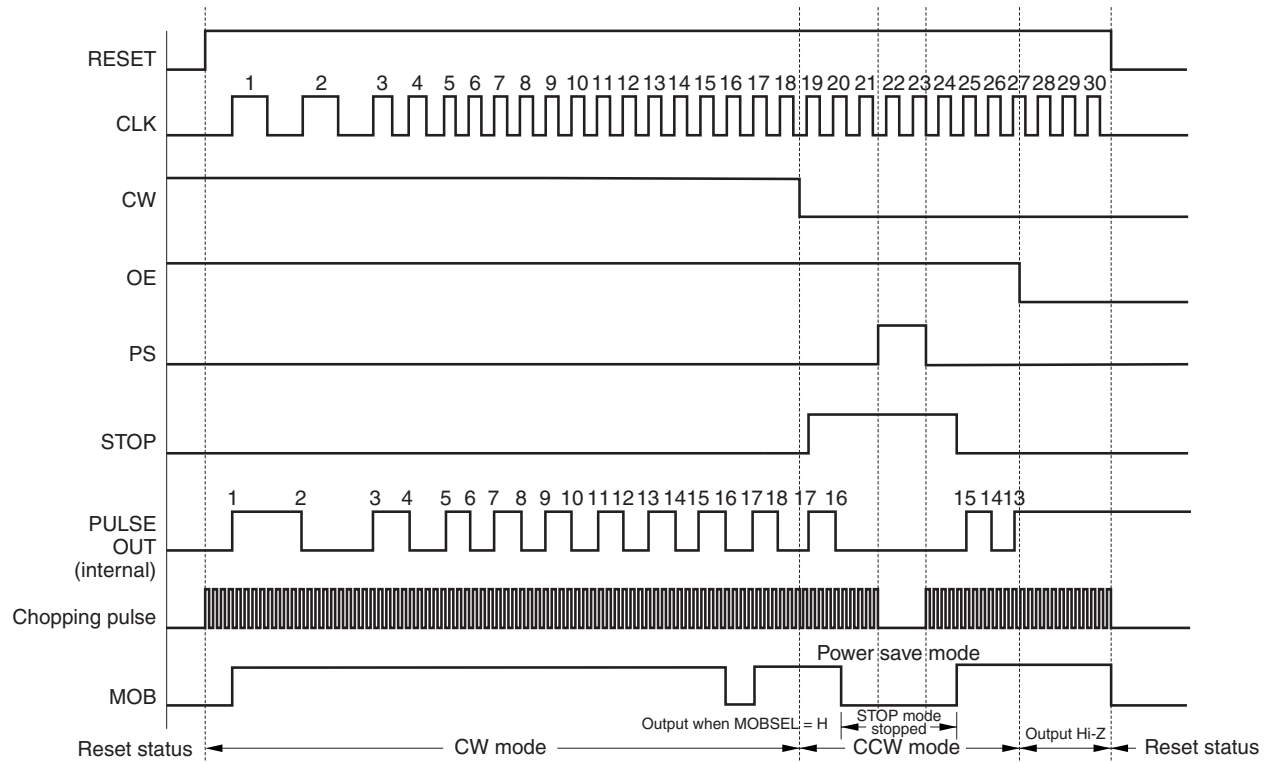

**Standard Connection Diagram**

Microstep/2-phase excitation driving

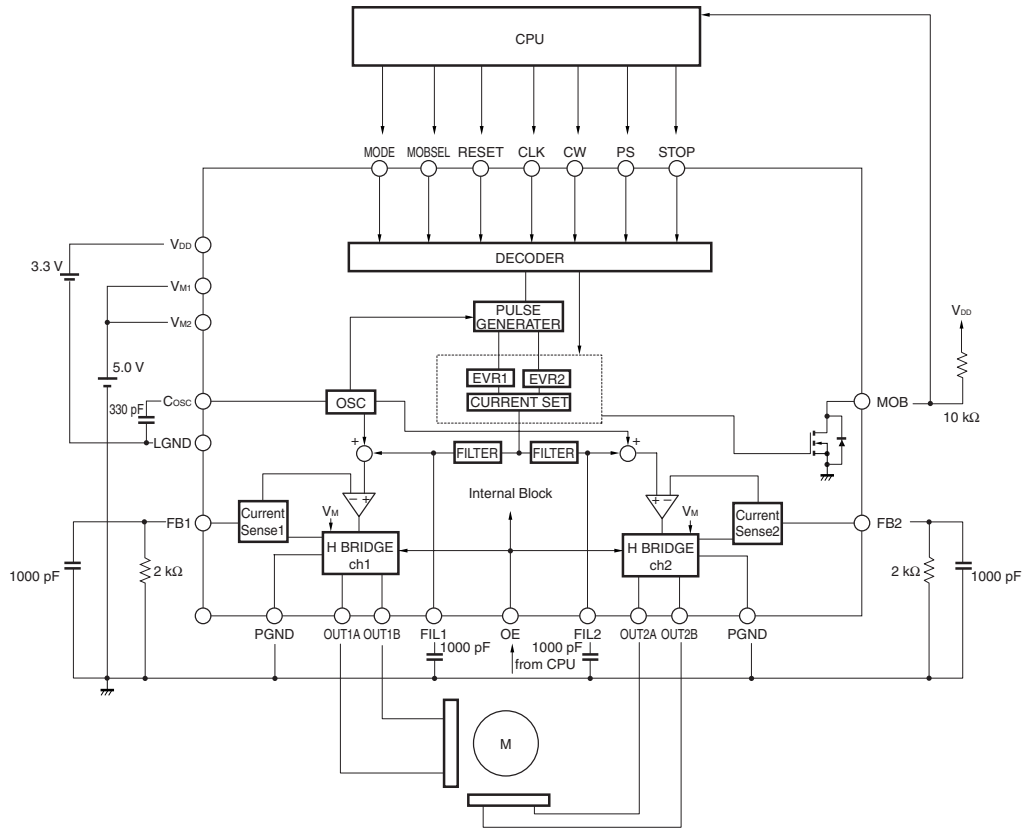

Only 2-phase excitation driving

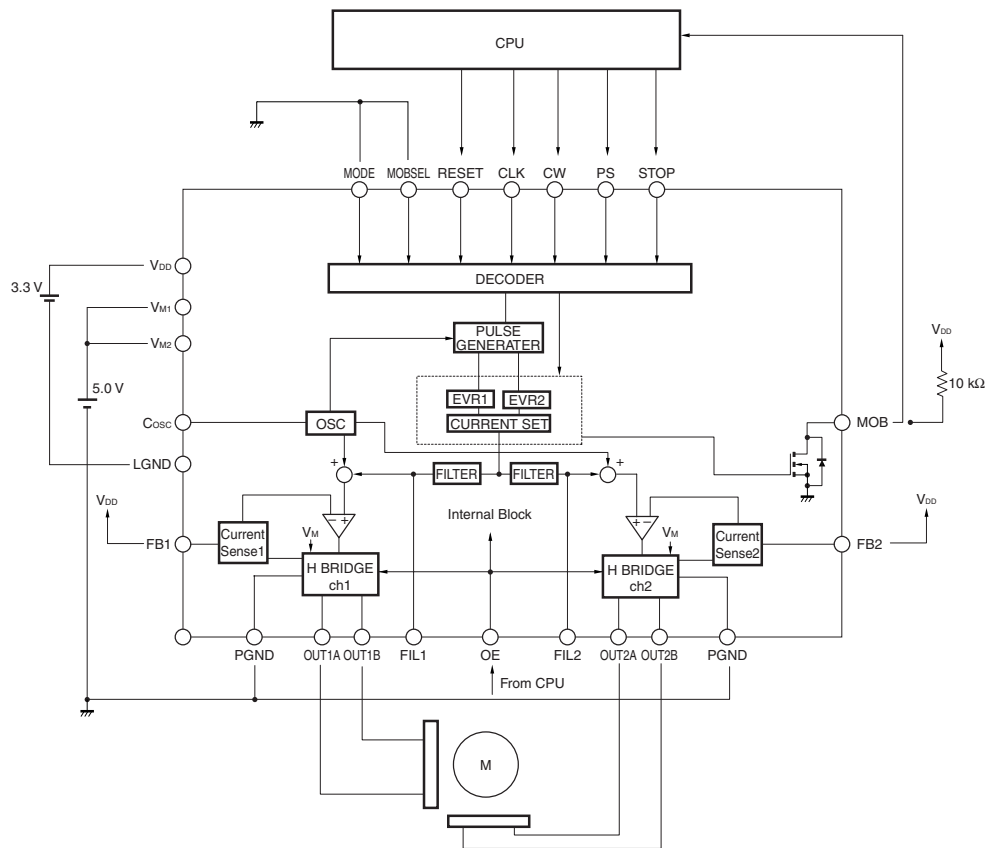

Output Timing Chart

- Microstep output mode

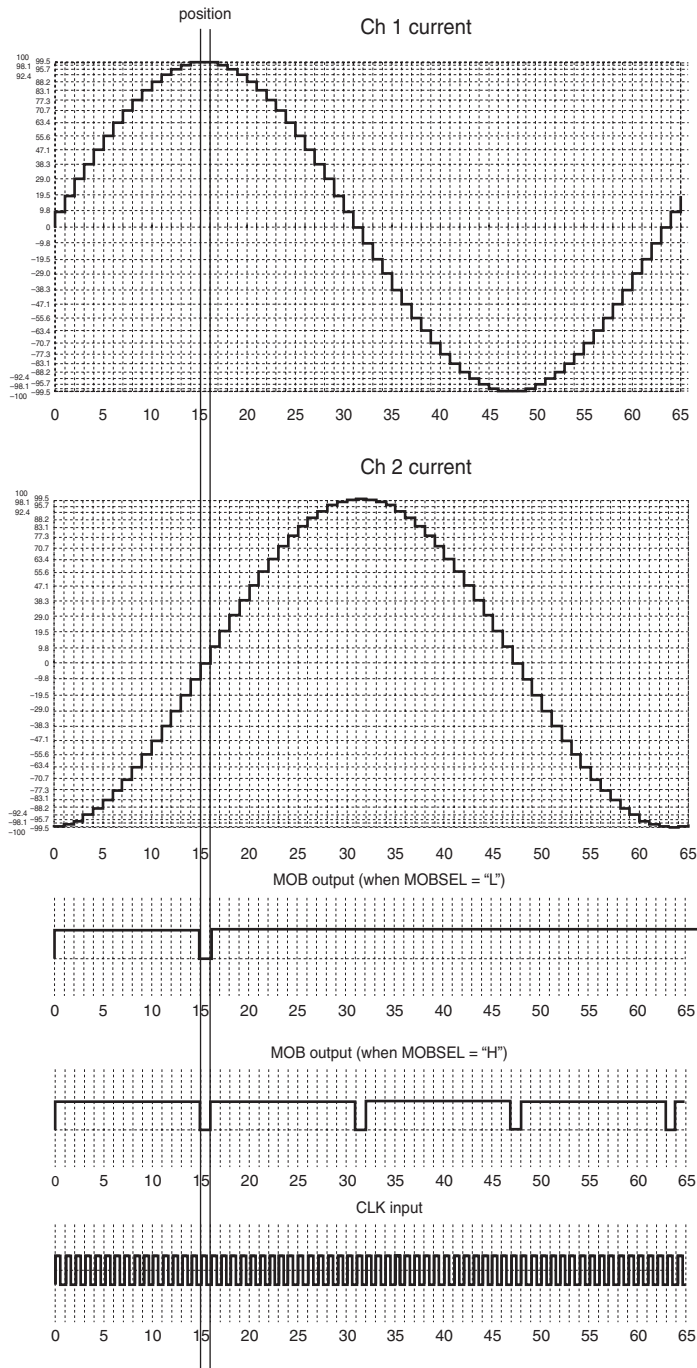

The horizontal axis indicates the number of steps. This figure shows an example in the CW mode. The pulse advances in synchronization with the rising edge of CLK. The current flows into ch 1 and ch 2 in the positive direction when it flows from OUT1A to OUT1B, and in the negative direction when it flows from OUT1B to OUT1A (the values shown above are ideal values and do not indicate the actual values).

**Output Timing Chart**

- 2-phase excitation output mode

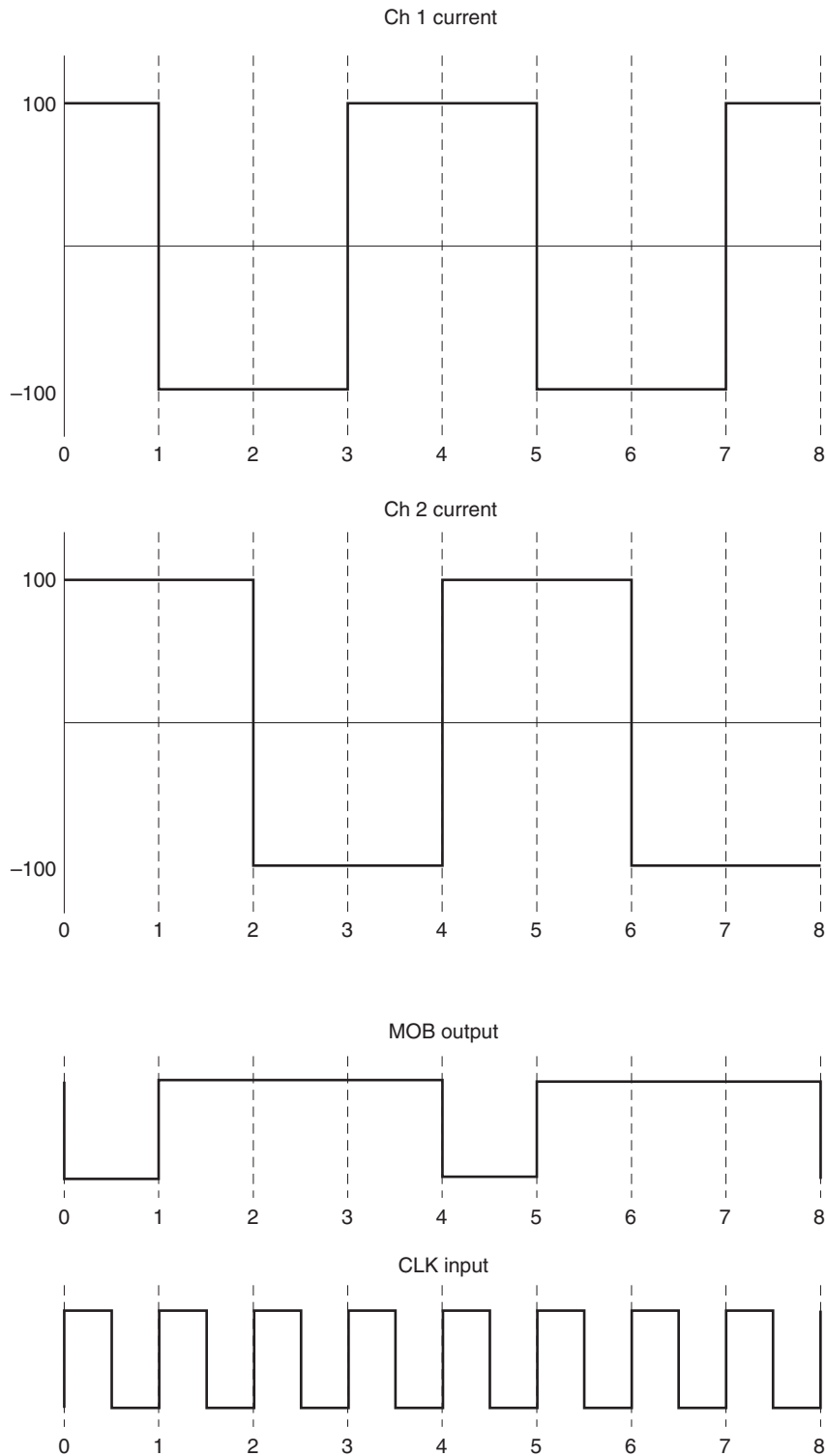

The horizontal axis indicates the number of steps. This figure shows an example in the CW mode. The current flows into ch 1 and ch 2 in the positive direction when it flows from OUT1A to OUT1B, and in the negative direction when it flows from OUT1B to OUT1A.

Relationship Between Revolution Angle, Phase Current, and Vector Amount (64 microsteps)

Step	Revolution Angle	Phase A – Phase Current			Phase B – Phase Current			Vector Amount
		Min.	Typ.	Max.	Min.	Typ.	Max.	Typ.
θ0	0	–	0	3.8	–	100	–	100
θ1	5.625	2.5	9.8	17.0	94.5	100	104.5	100.48
θ2	11.250	12.4	19.5	26.5	93.2	98.1	103.0	100
θ3	16.875	22.1	29.0	36.1	90.7	95.7	100.7	100.02
θ4	22.500	31.3	38.3	45.3	87.4	92.4	97.4	100.02
θ5	28.125	40.1	47.1	54.1	83.2	88.2	93.2	99.99
θ6	33.750	48.6	55.6	62.6	78.1	83.1	88.1	99.98
θ7	39.375	58.4	63.4	68.4	72.3	77.3	82.3	99.97
θ8	45	65.7	70.7	75.7	65.7	70.7	75.7	99.98
θ9	50.625	72.3	77.3	82.3	58.4	63.4	68.4	99.97
θ10	56.250	78.1	83.1	88.1	48.6	55.6	62.6	99.98
θ11	61.875	83.2	88.2	93.4	40.1	47.1	54.1	99.99
θ12	67.500	87.4	92.4	97.4	31.3	38.3	45.3	100.02
θ13	73.125	90.7	95.7	100.7	22.1	29.0	36.1	100.02
θ14	78.750	93.2	98.1	103.0	12.4	19.5	26.5	100
θ15	84.375	94.5	100	104.5	2.5	9.8	17.0	100.48
θ16	90	–	100	–	–	0	3.8	100

The above values are ideal values and are not guaranteed values.

**FUNCTION DESCRIPTION**

**2-phase excitation driving mode**

By allowing a current of ±100% to flow into output ch1 and ch2 at the same time, a motor can be driven with the larger torque.

The two-phase excitation driving mode and microstep driving mode are switched by the MODE pin. In the two-phase excitation driving mode, the chopping pulse circuit does not operate.

**Microstep driving of stepper motor**

To position a stepper motor with high accuracy, the μPD168110 has a function to hold constant the current flowing through the H bridge by a vector value and to stop one cycle in 64 steps. To realize the microstep driving mode, the driver internally realizes the following functions.

- Detecting the current flowing into each channel as a voltage value by a sense resistor
- Synthesizing the dummy sine wave of the half-wave generated by the internal D/A and PWM oscillation wave for chopping operation
- The driver stage performs PWM driving based on the result of comparing the detected voltage value and synthesized waves.

The internal dummy sine wave is of 64 steps per cycle, so that the stepper motor can be driven in 64 steps. The microstep driving mode and two-phase excitation driving mode are switched by an external pin.

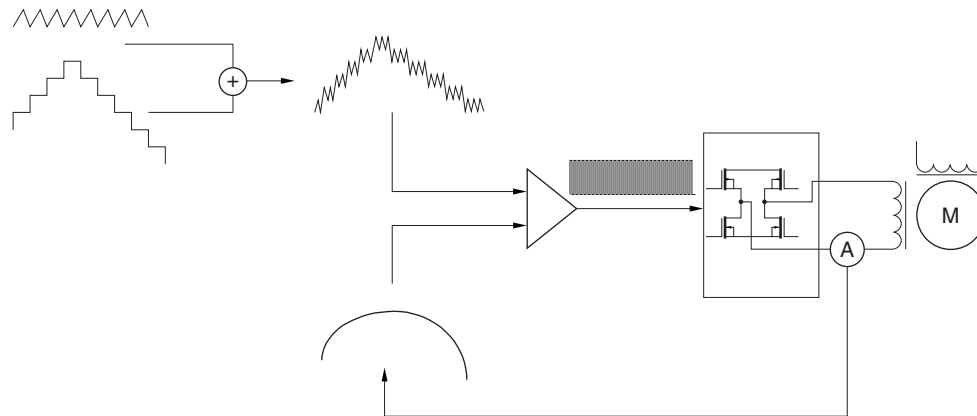

Concept of microstep driving operation

**MOB output**

The MOB output pin outputs “L” if the current of ch1 or ch2 reaches ±100% in the microstep output mode, or if the current of ch 1 reaches +100%. In the two-phase excitation output mode, the MOB pin outputs “L” when the current of ch1 and ch2 reaches +100%. The excitation position of the stepper motor can be checked by monitoring the MOB output. The MOB output also indicates the stop position information in the stop mode to be explained below.

The MOB output goes into a Hi-Z state (output H level if pulled up) when OE = “L”.

**Stop mode**

If the stop mode is set by the STOP pin, the pulse is automatically output until MOB = “L” when CLK is input. If MOB = “L” in the stop mode, the pulse is not output even when CLK is input, and the output holds the excitation status.

To advance the pulse, release the stop mode and restore the normal mode.

**Reset function**

When RESET = "L", initialization is executed and the output goes into a Hi-Z state. When RESET = "H", excitation is started with the current of ch1 at +100% and the current of ch2 at 0% (one-phase excitation position). To perform two-phase excitation driving, excitation is started with the currents of ch1 and ch2 at +100% after the mode has been set. Be sure to execute a reset operation after power application. MOB outputs "L" until the pulse is output when RESET goes "L".

**Output enable (OE) pin**

The pulse output can be forcibly stopped from an external source by using the OE pin. When OE = "L", the output is forcibly made to go into a Hi-Z state.

**Standby function**

The  $\mu$ PD168110 can enter the standby mode when the pulse is not output and when PS = "H" and STOP = "H". In the standby mode, as many internal circuits as possible are stopped so that the self current consumption can be reduced. In the standby mode, the current consumption is 1  $\mu$ A MAX. when external CLK input is stopped. While CLK is being input, the current consumption is reduced to 300  $\mu$ A MAX. by the current flowing into the input buffer. The standby mode is released when PS = "L" and STOP = "L".

**Under voltage lockout circuit (UVLO)**

This function is used to forcibly stop the operation of the IC to prevent malfunction of the circuits if  $V_{DD}$  of the IC drops during operation. Note that if the  $V_{DD}$  voltage abruptly drops in the order of  $\mu$ s, this function may not operate.

 **$V_M$  pin current shutdown circuit**

A circuit that prevents a current from flowing into the  $V_M$  pin when  $V_{DD} = 0$  V is provided. Therefore, the current flowing into the  $V_M$  pin is cut off when  $V_{DD} = 0$  V.

A current of up to 3  $\mu$ A flows into the  $V_M$  pin when  $V_{DD}$  is applied so that the voltages on the  $V_{DD}$  and  $V_M$  pins can be monitored.

**OPERATION DESCRIPTION**

- Setting output current

The peak value of the output current (when current of ch 1 or ch 2 is 100%) is determined by the resistor R<sub>FB</sub> that is connected to FB1 and FB2. This IC has an internal reference power supply V<sub>REF</sub> (500 mV TYP.) for comparing current, and drives the stepper motor with the current value calculated by R<sub>FB</sub> and V<sub>REF</sub> as the peak output current value.

★ Peak output current value I<sub>MAX</sub> (A) ≡ V<sub>REF</sub> (V) ÷ R<sub>FB</sub> (Ω) x Output detection ratio

- Pulse output

The motor is driven by inputting a pulse to the CLK pin. The motor advances by one pulse at the rising edge of the CLK signal. When MODE = “H”, the motor is driven in the 64-microstep driving mode, and the driving current of each step is determined based on the internal motor excitation position information and revolution direction. When MODE = “L”, the two-phase excitation mode is selected, and the current direction (100% drive) of ch 1 and ch 2 are switched each time a pulse has been input.

- Setting motor revolution direction

The revolution direction of the motor is set by CW. In the CW mode (CW = “L”), the current of ch2 is output, 90° degrees in phase behind the current of ch1. In the CCW mode (CW = “H”), the current of ch2 is output, 90° degrees in phase ahead of the current of ch1.

CW Pin	Operation Mode
L	CW mode (forward revolution)
H	CCW mode (reverse revolution)

- Setting stop mode (valid only in microstep driving mode)

When STOP = “H”, the motor advances to the position of MOB output = “L”, and the output status is held.

The excitation status is not changed even when a pulse is input to CLK while MOB = “L” when STOP = “H”. The pulse can be advanced when STOP = “L”.

STOP	Operation Mode
L	Normal mode
H	Stop mode

**Caution** If STOP = “L” before the stop mode is set (until MOB = “L”), the operation is performed in the same manner as in the normal mode.

• **Power save mode (valid only in microstep driving mode)**

When PS = “H” and STOP = “H”, the motor advances to the position of MOB output = “L” and then the output goes to a Hi-Z state.

The internal circuitry is stopped as much as possible and the standby mode is set. The power save mode is released when PS = “L” and STOP = “L”.

STOP	Operation Mode
L	Normal mode
H	Power save mode (only when STOP = “H”)

**Caution** Inputting PS = “H” and STOP = “L” is prohibited.

• **Setting output enable**

When OE = “H”, the motor is driven (output excitation status). Be sure to set OE to “H” to drive the motor.

STOP	Operation Mode
L	Output Hi-Z
H	Enable mode

• **Selecting two-phase excitation/microstep driving mode**

The MODE pin can be used to select the two-phase excitation or microstep driving mode. When MODE = “H”, the microstep driving mode is selected. When MODE = “L”, the two-phase excitation mode (both ch 1 and ch 2 are driven at +100% or -100%) is selected. The μPD168110 is initialized immediately after a RESET operation, so excitation is started from the position at which the output current of ch 1 is 100% and the output current of ch 2 is 0% in the microstep driving mode, and from the position at which the output currents of both ch 1 and ch 2 are +100% in the two-phase excitation driving mode.

If the mode is changed from the microstep to the two-phase, the position of the microstep mode is retained until CLK is input. When the first CLK is input, pulse output is started, the operation skips to the two-phase position of the next quadrant, and driving is started.

MODE	Operation Mode
L	2-phase excitation
H	Microstep driving

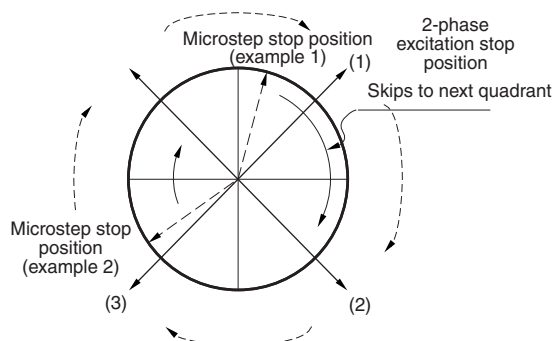

Concept of switching operation mode from microstep to 2-phase excitation

- Selecting MOB output (in microstep driving mode only)

The output function of MOB can be selected by MOBSEL. When MOBSEL = "L", MOB is output at the position where the current of ch1 is +100% and the current of ch2 is 0%. When MOBSEL = "H", MOB is output at the position where the current of ch1 or ch2 is ±100%.

MOBSEL	MOB Output
L	Current of ch1 is +100% and current of ch2 is 0% (1 pulse/cycle).
H	Current of ch1 or ch2 is ±100% (4 pulses/cycle).

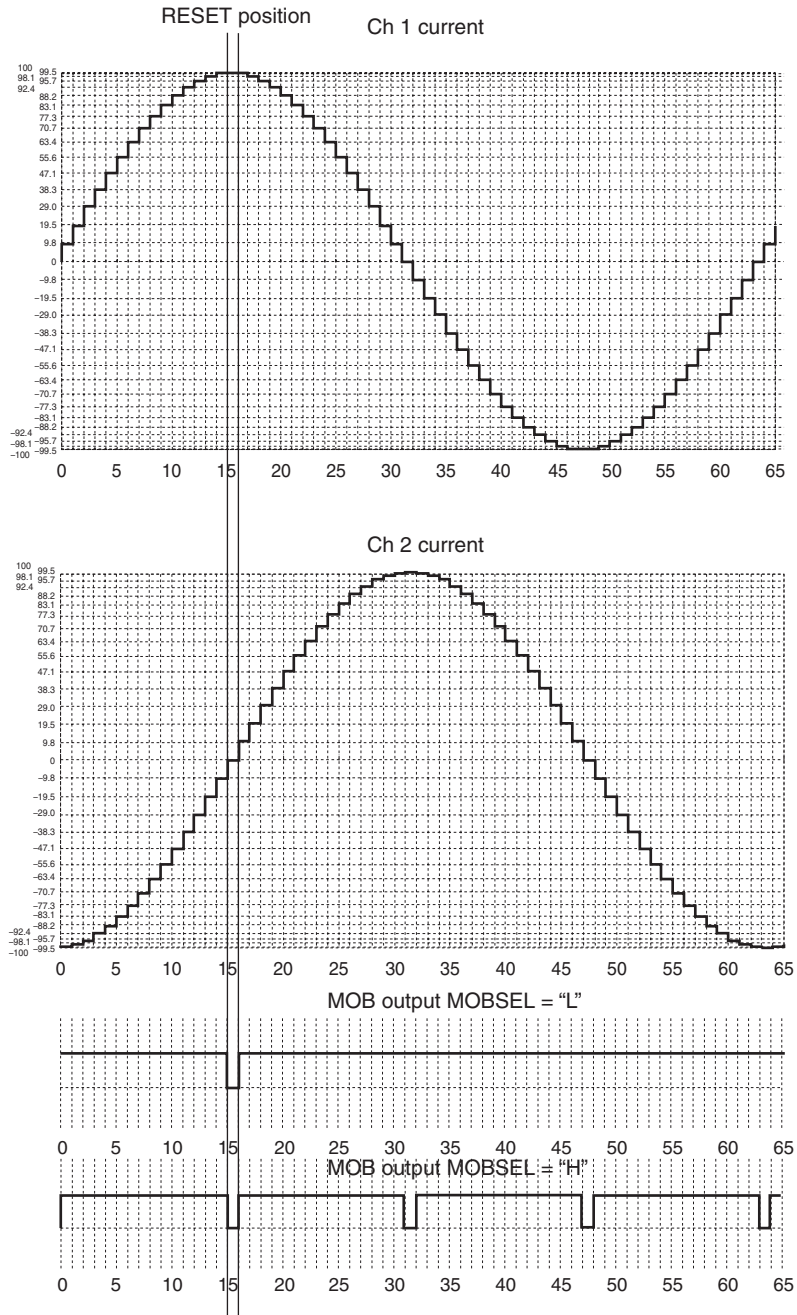

**ABSOLUTE MAXIMUM RATINGS**

**(T<sub>A</sub> = 25°C: GLASS EPOXY BOARD OF 100 mm × 100 mm × 1 mm WITH COPPER FOIL OF 15%)**

Parameter	Symbol	Conditions	Rating	Unit
Power supply voltage	V <sub>DD</sub>	Control block	-0.5 to +6.0	V
	V <sub>M</sub>	Motor block	-0.5 to +6.0	
Input voltage	V <sub>IN</sub>		-0.5 to V <sub>DD</sub> +0.5	V
Output pin voltage	V <sub>OUT</sub>		6.2	V
DC output current	I <sub>D(DC)</sub>	DC	±0.4	A/ch
Instantaneous output current	I <sub>D(pulse)</sub>	PW < 10 ms, Duty 20%	±0.7	A/ch
Power consumption	P <sub>T</sub>		0.7	W
Peak junction temperature	T <sub>CH(MAX)</sub>		150	°C
Storage temperature	T <sub>stg</sub>		-55 to +150	°C

**RECOMMENDED OPERATING CONDITIONS**

**(T<sub>A</sub> = 25°C: GLASS EPOXY BOARD OF 100 mm × 100 mm × 1 mm WITH COPPER FOIL OF 15%)**

Parameter	Symbol	Conditions	MIN.	TYP.	MAX.	Unit
Power supply voltage	V <sub>DD</sub>	Control block	2.7		3.6	V
	V <sub>M</sub>	Motor block	2.7		5.5	
Input voltage	V <sub>IN</sub>		0		V <sub>DD</sub>	V
DC output current	I <sub>D(DC)</sub>	DC	-0.35		+0.35	A/ch
Instantaneous output current	I <sub>D(pulse)</sub>	PW < 10 ms, Duty ≤ 20%	-0.6		+0.6	A/ch
MOB pin output sink current	I <sub>MOB</sub>	Open-drain output			5	mA
Operating temperature range	T <sub>A</sub>		-10		75	°C

**ELECTRICAL CHARACTERISTICS (UNLESS OTHERWISE SPECIFIED,  $V_{DD} = V_M = 3\text{ V}$ ,  $T_A = 25^\circ\text{C}$ )**

Parameter	Symbol	Conditions	MIN.	TYP.	MAX.	Unit
$V_{DD}$ pin current after reset	$I_{DD(STB)}$	External CLK stopped			1.0	μA
$V_{DD}$ pin current in standby mode	$I_{DD(STB2)}$	External CLK stopped			30	μA
	$I_{DD(STB3)}$	External CLK is input			300	μA
$V_{DD}$ pin current during operation	$I_{DD(ACT)}$				3.0	mA
$V_M$ pin current	$I_{M(OFF)}$	$V_M = 5.5\text{ V}$ per $V_M$ pin, after reset and in standby mode			3.0	μA
High-level input current	$I_{IH}$	$V_{IN} = V_{DD}$			1.0	μA
Low-level input current	$I_{IL}$	$V_{IN} = 0\text{ V}$	-1.0			μA
High-level input voltage	$V_{IH}$	$2.7\text{ V} \leq V_{DD} \leq 3.6\text{ V}$	$0.7 \times V_{DD}$			V
Low-level input voltage	$V_{IL}$	$2.7\text{ V} \leq V_{DD} \leq 3.6\text{ V}$			$0.3 \times V_{DD}$	V
Input hysteresis voltage	$V_{hys}$			0.3		V
H bridge on-resistance	$R_{ON}$	$I_M = 0.35\text{ A}$ , sum of upper and lower stages, $FB1 = FB2 = 0\text{ V}$			2.0	Ω
Output turn-on time	$t_{ON}$	$R_M = 20\ \Omega$ OE pin $\uparrow \rightarrow$ output SW time	0.02		0.5	μs
Output turn-off time	$t_{OFF}$		0.02		0.5	μs
Internal reference voltage	$V_{REF}$		450	500	550	mV
Output detection ratio		$I_M = 0.1\text{ A}$ , with $5\text{ k}\Omega$ sense resistor connected	950	1050	1150	

★

- Cautions 1.** The undervoltage lockout detection circuit (UVLO) operates at 1.7 V TYP. whereupon the output goes into a Hi-Z state. Internal data such as the excitation position information is reset. The UVLO circuit does not operate after reset.
- 2.** A shutdown circuit that prevents a current from flowing into the  $V_M$  pin when  $V_{DD} = 0\text{ V}$  is provided.

PACKAGE DRAWING

24-PIN PLASTIC TSSOP (5.72 mm (225))

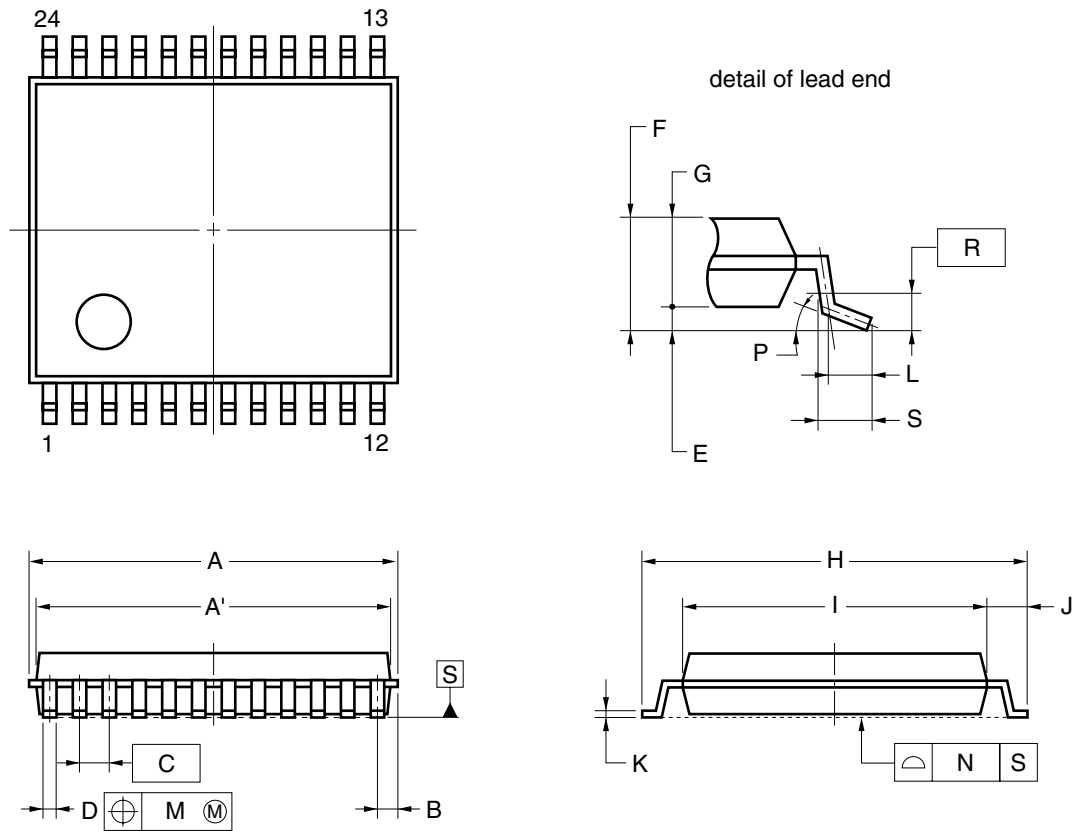

NOTE

Each lead centerline is located within 0.10 mm of its true position (T.P.) at maximum material condition.

ITEM	MILLIMETERS
A	6.65±0.10
A'	6.5±0.1
B	0.575
C	0.5 (T.P.)
D	0.22±0.05
E	0.1±0.05
F	1.2 MAX.
G	1.0±0.05
H	6.4±0.1
I	4.4±0.1
J	1.0±0.1
K	0.17±0.025
L	0.5
M	0.10
N	0.08
P	3° <sup>+5°</sup> <sub>-3°</sub>
R	0.25
S	0.6±0.15

P24MA-50-6A5

**RECOMMENDED SOLDERING CONDITIONS**

The μPD168110 should be soldered and mounted under the following recommended conditions.

For soldering methods and conditions other than those recommended below, contact an NEC Electronics sales representative.

For technical information, see the following website.

Semiconductor Device Mount Manual (<http://www.necel.com/pkg/en/mount/index.html>)

**Recommended Soldering Conditions for Surface Mounting Type**

**μPD168110MA-6A5 24pin TSSOP**

Soldering Method	Soldering Conditions	Recommended Condition Symbol
Infrared reflow	Package peak temperature: 260°C, Time: 60 seconds max. (at 220°C or higher), Count: Three times or less, Exposure limit: None, Flux: Rosin flux with low chlorine (0.2 Wt% or below) recommended	IR60-00-3

**Caution Do not use different soldering methods together (except for partial heating).**

- **The information in this document is current as of June, 2005. The information is subject to change without notice. For actual design-in, refer to the latest publications of NEC Electronics data sheets or data books, etc., for the most up-to-date specifications of NEC Electronics products. Not all products and/or types are available in every country. Please check with an NEC Electronics sales representative for availability and additional information.**
- No part of this document may be copied or reproduced in any form or by any means without the prior written consent of NEC Electronics. NEC Electronics assumes no responsibility for any errors that may appear in this document.
- NEC Electronics does not assume any liability for infringement of patents, copyrights or other intellectual property rights of third parties by or arising from the use of NEC Electronics products listed in this document or any other liability arising from the use of such products. No license, express, implied or otherwise, is granted under any patents, copyrights or other intellectual property rights of NEC Electronics or others.
- Descriptions of circuits, software and other related information in this document are provided for illustrative purposes in semiconductor product operation and application examples. The incorporation of these circuits, software and information in the design of a customer's equipment shall be done under the full responsibility of the customer. NEC Electronics assumes no responsibility for any losses incurred by customers or third parties arising from the use of these circuits, software and information.
- While NEC Electronics endeavors to enhance the quality, reliability and safety of NEC Electronics products, customers agree and acknowledge that the possibility of defects thereof cannot be eliminated entirely. To minimize risks of damage to property or injury (including death) to persons arising from defects in NEC Electronics products, customers must incorporate sufficient safety measures in their design, such as redundancy, fire-containment and anti-failure features.
- NEC Electronics products are classified into the following three quality grades: "Standard", "Special" and "Specific".

The "Specific" quality grade applies only to NEC Electronics products developed based on a customer-designated "quality assurance program" for a specific application. The recommended applications of an NEC Electronics product depend on its quality grade, as indicated below. Customers must check the quality grade of each NEC Electronics product before using it in a particular application.

"Standard": Computers, office equipment, communications equipment, test and measurement equipment, audio and visual equipment, home electronic appliances, machine tools, personal electronic equipment and industrial robots.

"Special": Transportation equipment (automobiles, trains, ships, etc.), traffic control systems, anti-disaster systems, anti-crime systems, safety equipment and medical equipment (not specifically designed for life support).

"Specific": Aircraft, aerospace equipment, submersible repeaters, nuclear reactor control systems, life support systems and medical equipment for life support, etc.

The quality grade of NEC Electronics products is "Standard" unless otherwise expressly specified in NEC Electronics data sheets or data books, etc. If customers wish to use NEC Electronics products in applications not intended by NEC Electronics, they must contact an NEC Electronics sales representative in advance to determine NEC Electronics' willingness to support a given application.

(Note)

- (1) "NEC Electronics" as used in this statement means NEC Electronics Corporation and also includes its majority-owned subsidiaries.
- (2) "NEC Electronics products" means any product developed or manufactured by or for NEC Electronics (as defined above).