

PRELIMINARY DATA SHEET

# SKY65129-11: 1.98-2.02 GHz High Linearity 4 W Power Amplifier

## Applications

- Satellite phones/SATCOM
- WCDMA
- PCS

## Features

- Output power: +36 dBm
- High gain: 30 dB
- Wide dynamic range RF detector
- Internal 50 Ω RF match and bias circuits
- Internal on/off control circuit
- Single DC supply: +5 V
- Small footprint, MCM (20-pin, 6 x 6 mm) SMT package (MSL3, 250 °C per JEDEC J-STD-020)



Skyworks offers lead (Pb)-free RoHS (Restriction of Hazardous Substances) compliant packaging.

## Description

Skyworks SKY65129-11 is a Microwave Monolithic Integrated Circuit (MMIC) Power Amplifier (PA) with superior output power, linearity, and efficiency. The device is optimized to operate in the 2 GHz frequency band, which makes it ideal for PCS satellite, PCS cellular, and UMTS applications.

The high linearity (high OP1dB and excellent ACLR) and high efficiency of the SKY65129-11 make it ideal for use at the final stage (or close to the final stage) in a transmit chain.

The device is fabricated using Skyworks high reliability Heterojunction Bipolar Transistor (HBT) technology. The device is internally matched and mounted in a 20-pin, 6 x 6 mm Multi-Chip Module (MCM) Surface-Mounted Technology (SMT) package, which allows for a highly manufacturable low cost solution.

The device package and pinout for the 20-pin MCM are shown in Figure 1. A block diagram of the SKY65129-11 is shown in Figure 2.

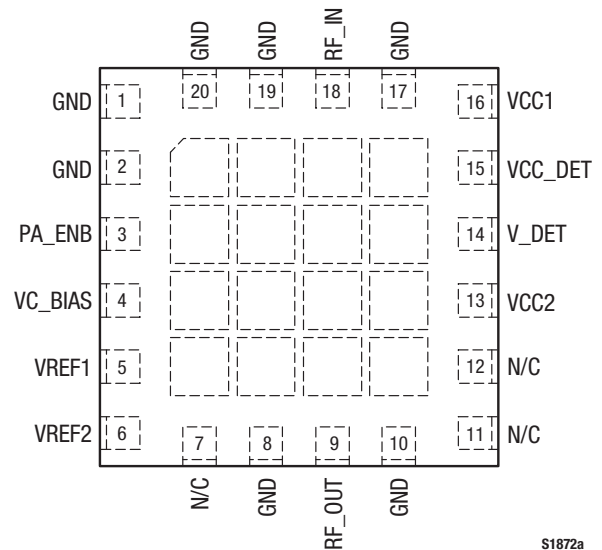

**Figure 1. SKY65129-11 Pinout – 20-Pin MCM (Top View)**

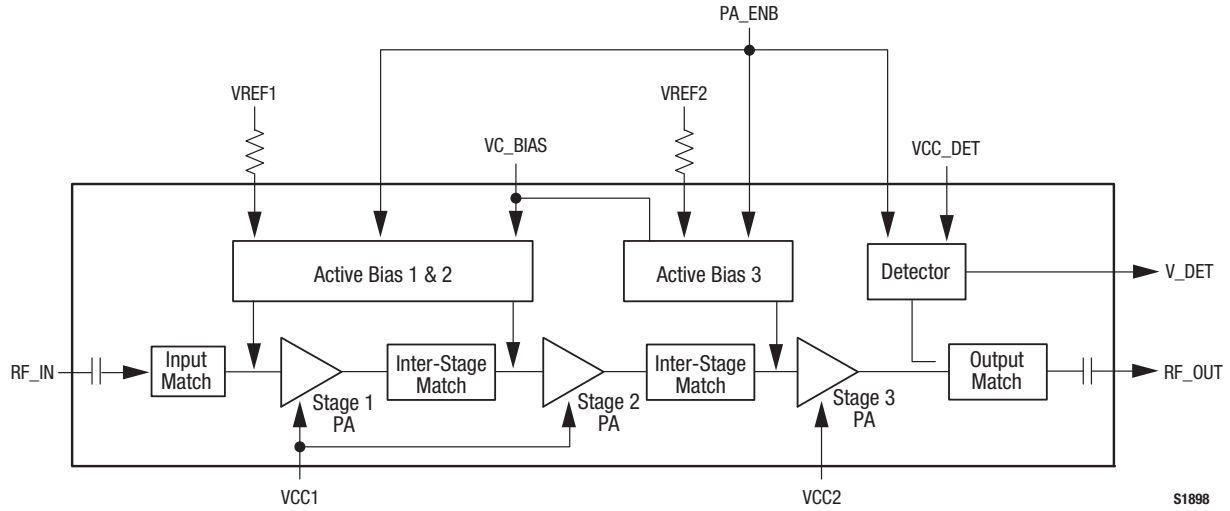

Figure 2. SKY65129-11 Block Diagram

**Technical Description**

The SKY65129-11 PA contains all of the needed RF matching and DC biasing circuits. The device also provides an output power detector voltage.

The SKY65129-11 is a three-stage, HBT InGaP device optimized for high linearity and power efficiency. These features make the device suitable for wideband digital applications, where PA linearity and power consumption are of critical importance (e.g., WLANs).

The device has been characterized with the highest specified data rates for  $\pi/4$  DQPSK. Under these stringent test conditions, the device exhibits excellent spectral purity and power efficiency.

**Electrical and Mechanical Specifications**

Signal pin assignments and functional pin descriptions are described in Table 1. The absolute maximum ratings of the SKY65129-11 are provided in Table 2. Electrical specifications are provided in Table 3.

Typical performance characteristics of the SKY65129-11 are illustrated in Figures 3 to 12.

Table 1. SKY65129-11 Signal Descriptions

Pin #	Name	Description	Pin #	Name	Description
1	GND	Ground	11	N/C	No connection
2	GND	Ground	12	N/C	No connection
3	PA_ENB	PA on/off control signal (on: 1.6 V, off: 0 to 0.5 V)	13	VCC2	Stage 3 collector voltage
4	VC_BIAS	Bias voltage	14	V_DET	Detector output signal
5	VREF1	Reference voltage for stages 1 and 2	15	VCC_DET	Detector supply voltage
6	VREF2	Reference voltage for stage 3	16	VCC1	Stages 1 & 2 collector voltage
7	N/C	No connection	17	GND	Ground
8	GND	Ground	18	RF_IN	RF input
9	RF_OUT	RF output	19	GND	Ground
10	GND	Ground	20	GND	Ground

**Table 2. SKY65129-11 Absolute Maximum Ratings (Note 1)**

Parameter	Symbol	Minimum	Maximum	Units
RF output power	P <sub>OUT</sub>		+36	dBm
RF signal duty cycle			50	%
Supply voltage	VREF1, VREF2, VCC_DET, VCC1, VCC2, and VC_BIAS		5.5	V
Total peak supply current under CW conditions	I <sub>CC_TOTAL</sub>		2000	mA
Case operation temperature	T <sub>C</sub>	-40	+85	°C
Storage temperature	T <sub>ST</sub>	-55	+125	°C
Junction temperature	T <sub>J</sub>		+150	°C

**Note 1:** Exposure to maximum rating conditions for extended periods may reduce device reliability. There is no damage to device with only one parameter set at the limit and all other parameters set at or below their nominal value. Exceeding any of the limits listed here may result in permanent damage to the device.

**CAUTION:** Although this device is designed to be as robust as possible, Electrostatic Discharge (ESD) can damage this device. This device must be protected at all times from ESD. Static charges may easily produce potentials of several kilovolts on the human body or equipment, which can discharge without detection. Industry-standard ESD precautions should be used at all times.

**Table 3. SKY65129-11 Recommended Operating Conditions**

Parameter	Symbol	Minimum	Typical	Maximum	Units
Frequency range	f	1980		2020	MHz
RF input power (CW)	P <sub>IN</sub>		+3	+8	dBm
RF signal duty cycle			25	50	%
Supply voltage, measured at terminals of Evaluation Board	VREF1, VREF2, VCC_DET, VCC1, VCC2, and VC_BIAS		5.25	5.50	V
Ruggedness, load VSWR with no permanent damage, $\pi/4$ DQPSK modulated signal, P <sub>IN</sub> < +4 dBm	P <sub>MAX_LOAD</sub>		6:1		-
Case operating temperature	T <sub>C</sub>	-30		+85	°C

**Table 4. SKY65129-11 Electrical Specifications (Note 1)**

(VCC1, VCC2, VREF1, VREF2, VC\_BIAS = 5.25 V, PA\_ENB = 1.6 V, Tc = +25 °C, Test Frequency = 2.0 GHz, Unless Otherwise Noted)

Parameter	Symbol	Test Condition	Min	Typical	Max	Units
Small signal gain	IS21I	P <sub>IN</sub> = -10 dBm	27.0	29.5		dB
Output power @ 1 dB compression	OP1dB		+33.5	+34.5		dBm
Operating current	I <sub>OP</sub>	@ P1dB, CW	1.2		2.0	A
ACLR for P <sub>OUT</sub> = +33 dBm	ACLR1 ACLR2 ACLR3 ACLR4	$\pi/4$ DQPSK modulated signal, data rate = 31.25 kbps, 31.25 kHz offset		-35	-31 -46 -59 -66	dBc dBc dBc dBc
Quiescent Current	I <sub>Q</sub>	No RF input		425	500	mA
Power detector max level	V <sub>DET_MAX</sub>	P <sub>OUT</sub> = +33 dBm with CW signal	1.1	1.3	1.5	V
Power detector range	R <sub>N_DET</sub>	$\pi/4$ DQPSK modulated signal, data rate = 31.25 kbps	20	23		dB
Noise Figure	NF			8.5	9.5	dB
Input return loss	IS11I			-15	-10	dB
Output return loss	IS22I			-13	-10	dB
Reverse isolation measured at input port with CW signal injected at output port		RF power injected into output port = +20 dBm		-48	-44	dB

**Note 1:** Performance is guaranteed only under the conditions listed in this Table.

### Typical Performance Characteristics

(VCC1, VCC2, VREF1, VREF2, VC\_BIAS = 5.25 V, PA\_ENB = 1.6 V, Tc = +25 °C, Test Frequency = 2.0 GHz, Unless Otherwise Noted)

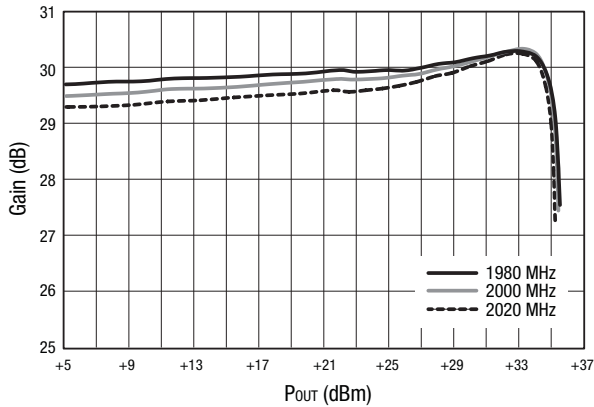

**Figure 3. Typical Gain vs Output Power Over Frequency**

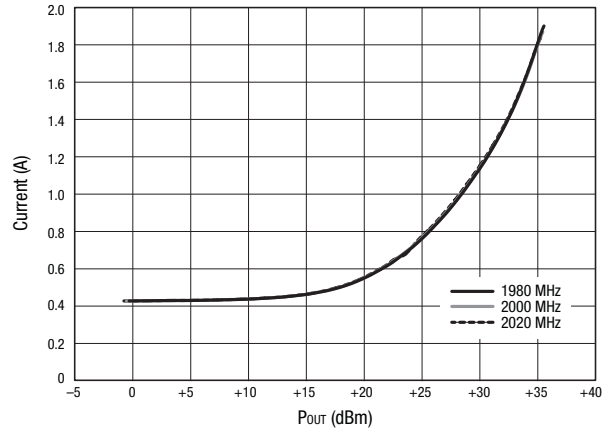

**Figure 4. Total Current vs Output Power Over Frequency**

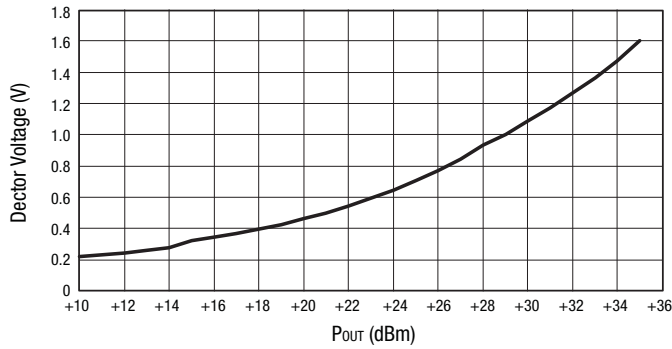

**Figure 5. Detector Voltage vs Output Power (CW Signal)**

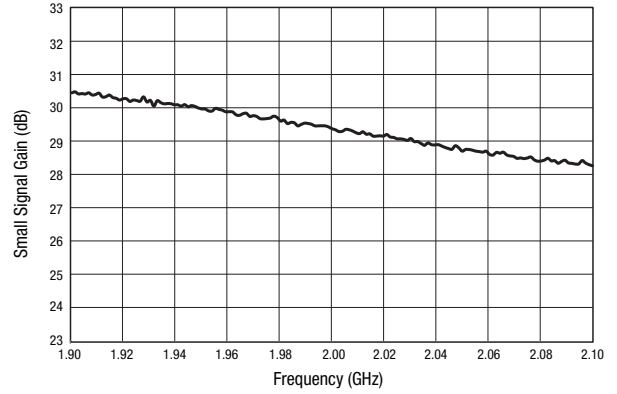

**Figure 6. Small Signal Gain Over Frequency**

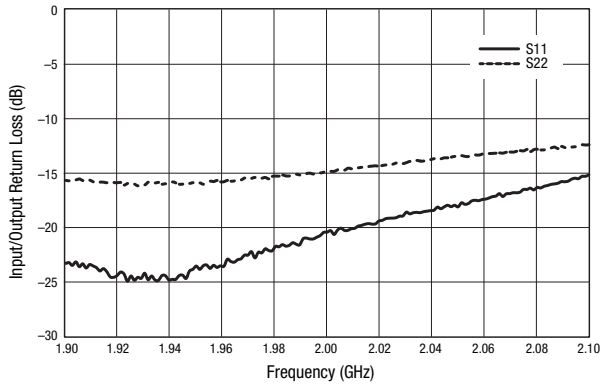

**Figure 7. Return Loss vs Frequency**

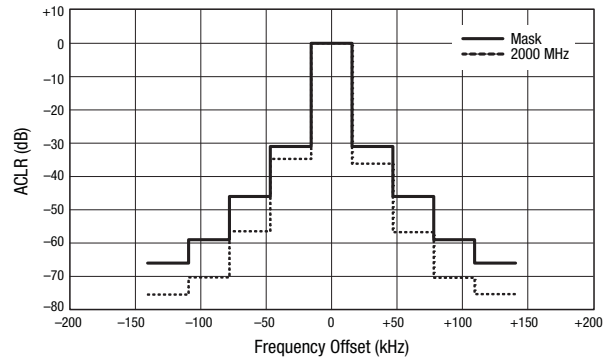

**Figure 8. ACLR vs Frequency Offset @ 2000 MHz**

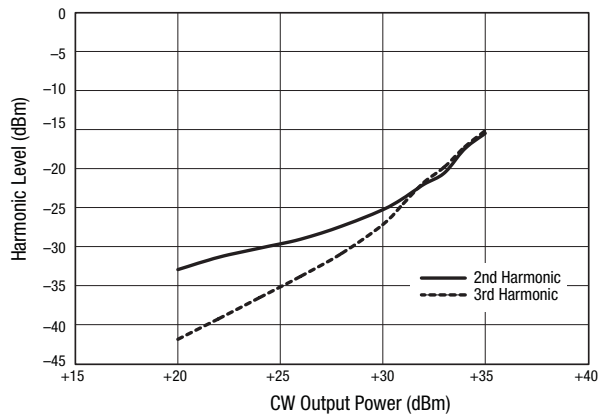

**Figure 9. Harmonics vs Output Power**

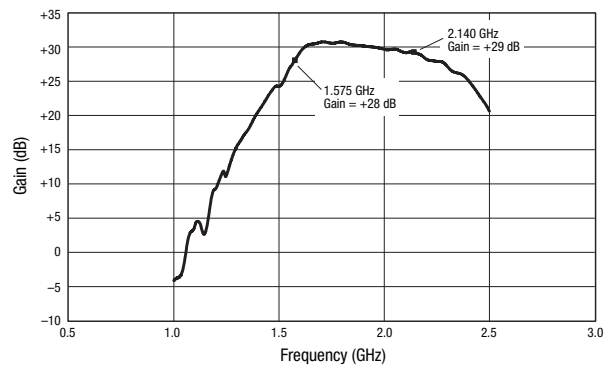

**Figure 10. Small Signal Gain vs Extended Frequency**

## Evaluation Board Description

The SKY65129-11 Evaluation Board is used to test the performance of the SKY65129-11 PA. A schematic diagram of the SKY65129-11 Evaluation Board is shown in Figure 11. Table 5 provides the Bill of Materials (BOM) list for Evaluation Board components. An assembly drawing for the Evaluation Board is shown in Figure 12 and the layer detail is provided in Figure 13.

For additional information on board design for thermal considerations, refer to the Skyworks Application Note, *PCB Design Guidelines for High Power Dissipation Packages* (document #201211).

## Package Dimensions

The PCB layout footprint for the SKY65129-11 is provided in Figure 14. Package dimensions for the 20-pin MCM are shown in Figure 15, and tape and reel dimensions are provided in Figure 16.

## Package and Handling Information

Since the device package is sensitive to moisture absorption, it is baked and vacuum packed before shipping. Instructions on the shipping container label regarding exposure to moisture after the container seal is broken must be followed. Otherwise, problems related to moisture absorption may occur when the part is subjected to high temperature during solder assembly.

The SKY65129-11 is rated to Moisture Sensitivity Level 3 (MSL3) at 250 °C. It can be used for lead or lead-free soldering. For additional information, refer to Skyworks Application Note, *PCB Design and SMT Assembly/Rework Guidelines for MCM-L Packages*, document number 101752.

Care must be taken when attaching this product, whether it is done manually or in a production solder reflow environment. Production quantities of this product are shipped in a standard tape and reel format.

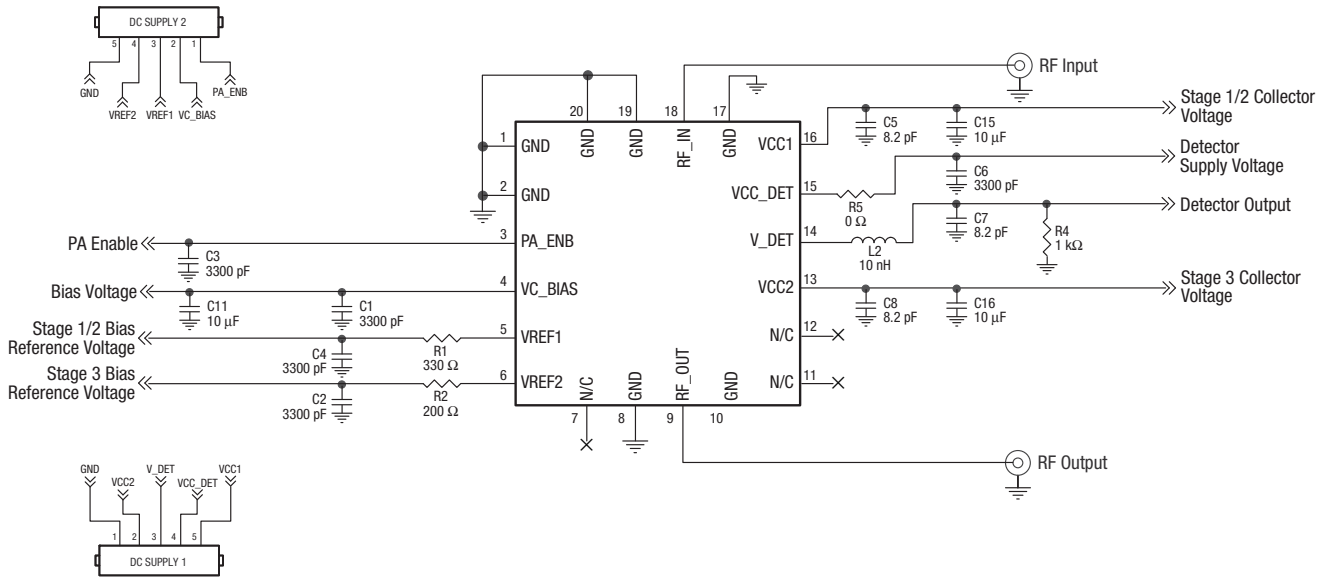

Note: Some component labels may be different than the corresponding component symbol shown here. Component values, however, are accurate as of the date of this Data Sheet.

S1899

Figure 11. SKY65129-11 Evaluation Board Schematic

Table 5. SKY65129-11 Evaluation Board Bill of Materials

Component	Description	Vendor	Part Number
C1, C3, C5, C7, C12	Ceramic, 3300 pF, X7R, 50 V, ±10%, 0603	Murata	GRM188R71H332KD01J
C4, C10, C15	Ceramic, 10 µF, X5R, 6 V, ±10%, 1206	TDK	C3216X5R0J106KT
C8, C11, C13	Ceramic, 8.2 pF, 50 V, ±5%, 0603	Murata	GRM1885C1H8R2CZ01D
L2	10 nH, fixed, SMT, ±5%, 0603	Taiyo-Yuden	HK160810NJ-T
R1	330 Ω, fixed, SMT, 50 V, ±5%, 063W, 0.0603	Rohm	MCR03EZHUJ330
R2	200 Ω, fixed, SMT, 50 V, ±5%, 063W, 0.0603	Rohm	MCR03EZHUJ200
R3	1 kΩ, fixed, SMT, 50 V, ±5%, 063W, 0.0603	Rohm	MCR03EZHUJ1000
R4	0 Ω, fixed, SMT, 50 V, ±5%, 063W, 0.0603	Rohm	MCR03EZHUJ000

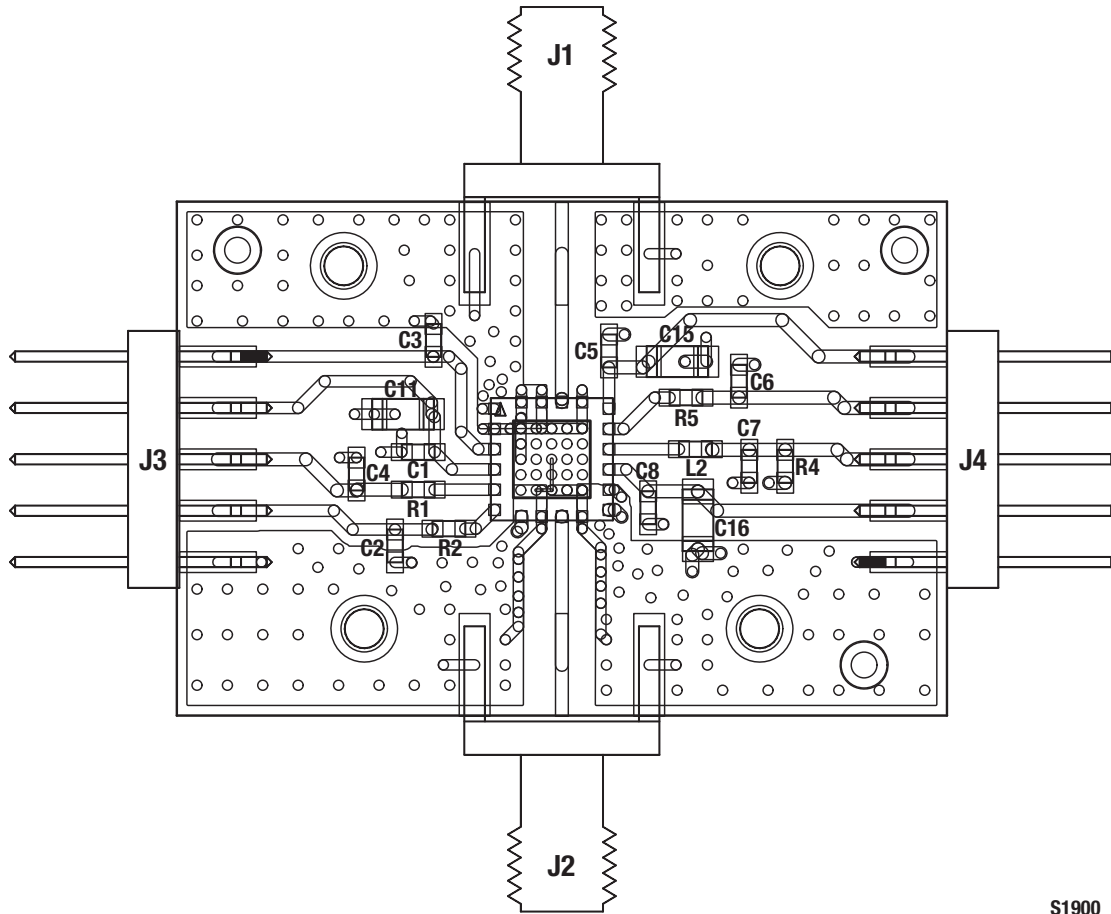

S1900

Figure 12. Evaluation Board Assembly Drawing

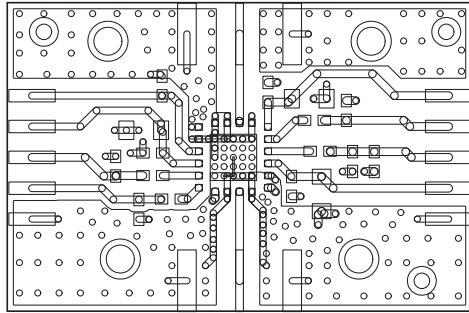

Layer 1: Top – Metal

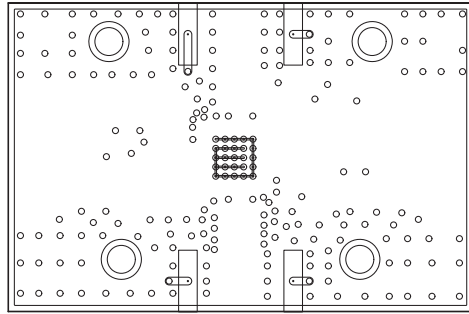

Layer 2: Ground

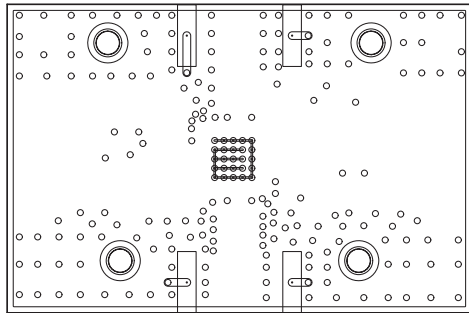

Layer 3: Ground

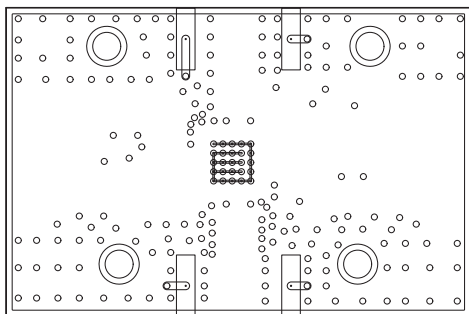

Layer 4: Solid Ground Plane

S1901

**Figure 13. SKY65129-11 Evaluation Board Layer Detail**

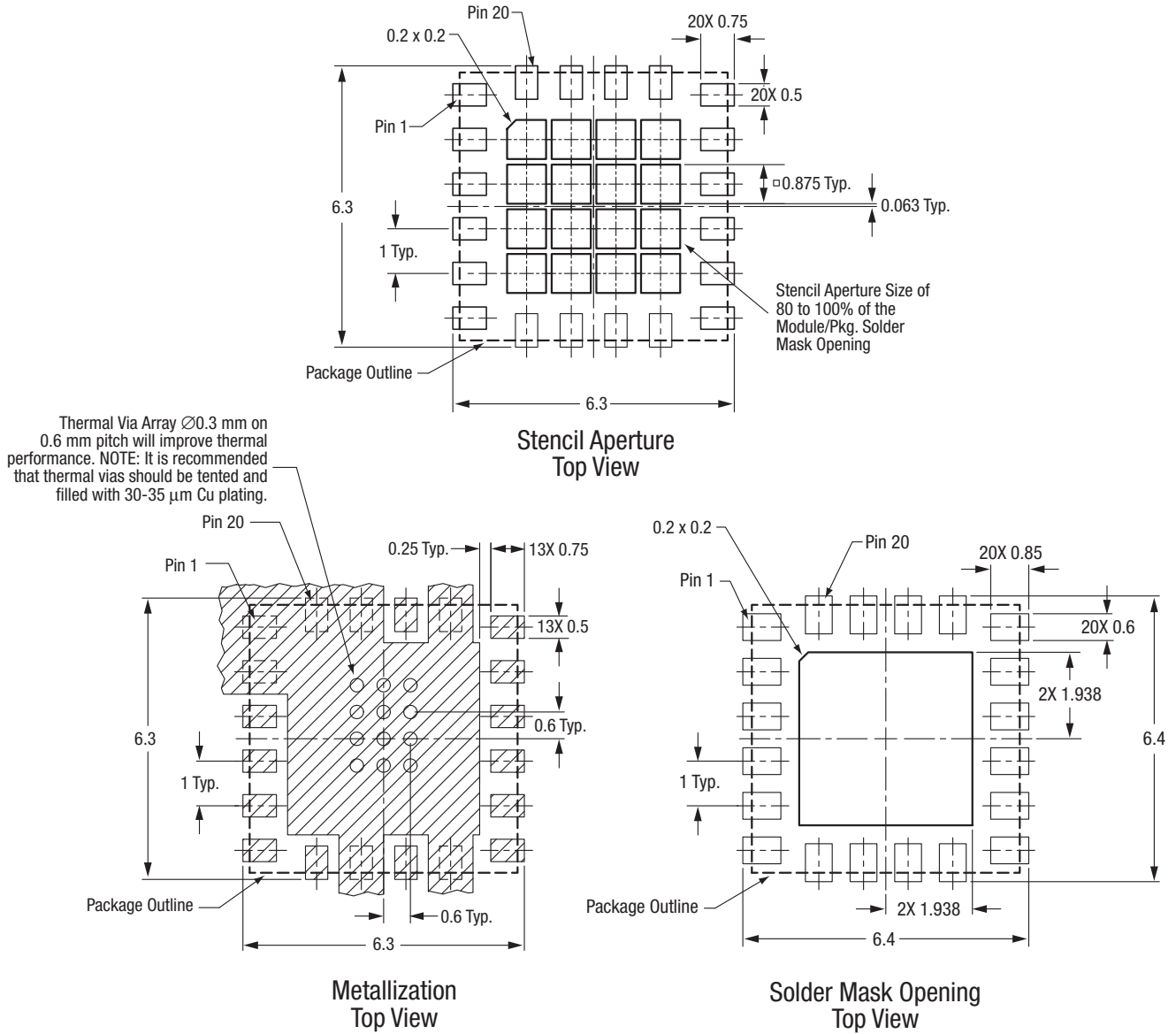

All dimensions are in millimeters

S1507

Figure 14. PCB Layout Footprint For The SKY65129-11

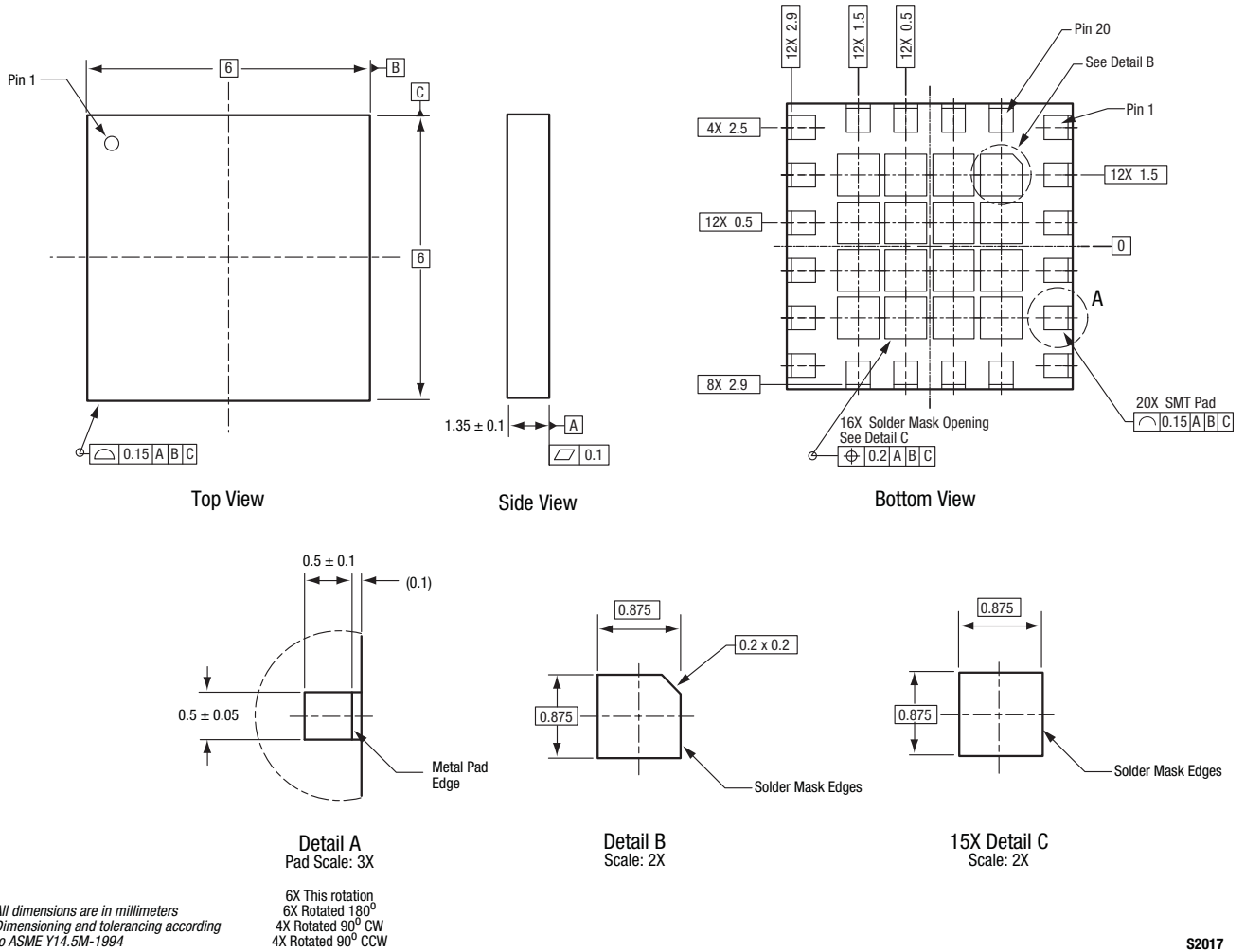
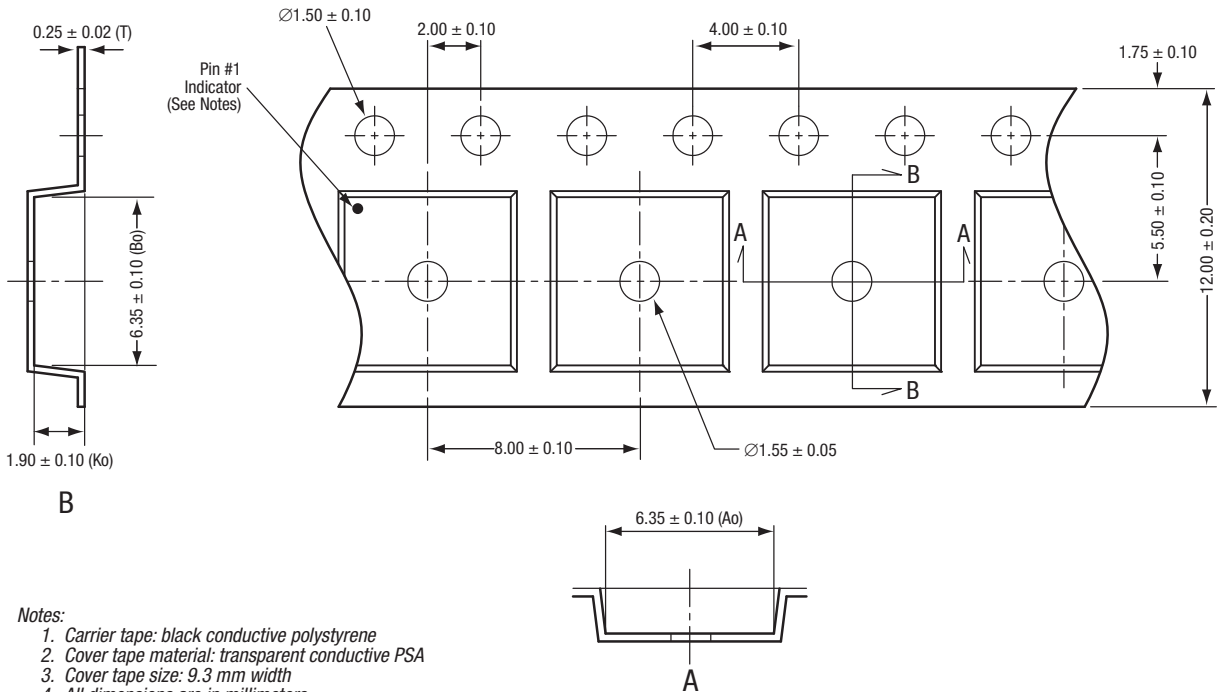

Figure 15. SKY65129-11 20-Pin MCM Package Dimensions



- Notes:
1. Carrier tape: black conductive polystyrene
  2. Cover tape material: transparent conductive PSA
  3. Cover tape size: 9.3 mm width
  4. All dimensions are in millimeters
  5. Ao and Bo measurement point is 0.3 mm from bottom pocket

S2018

Figure 16. SKY65129-11 20-Pin MCM Tape and Reel Dimensions

## Ordering Information

Model Name	Manufacturing Part Number	Evaluation Kit Part Number
SKY65129-11 1.98-2.02 GHz 4 W Power Amplifier	SKY65129-11	TW17-D540-001

Copyright © 2010 Skyworks Solutions, Inc. All Rights Reserved.

Information in this document is provided in connection with Skyworks Solutions, Inc. ("Skyworks") products or services. These materials, including the information contained herein, are provided by Skyworks as a service to its customers and may be used for informational purposes only by the customer. Skyworks assumes no responsibility for errors or omissions in these materials or the information contained herein. Skyworks may change its documentation, products, services, specifications or product descriptions at any time, without notice. Skyworks makes no commitment to update the materials or information and shall have no responsibility whatsoever for conflicts, incompatibilities, or other difficulties arising from any future changes.

No license, whether express, implied, by estoppel or otherwise, is granted to any intellectual property rights by this document. Skyworks assumes no liability for any materials, products or information provided hereunder, including the sale, distribution, reproduction or use of Skyworks products, information or materials, except as may be provided in Skyworks Terms and Conditions of Sale.

THE MATERIALS, PRODUCTS AND INFORMATION ARE PROVIDED "AS IS" WITHOUT WARRANTY OF ANY KIND, WHETHER EXPRESS, IMPLIED, STATUTORY, OR OTHERWISE, INCLUDING FITNESS FOR A PARTICULAR PURPOSE OR USE, MERCHANTABILITY, PERFORMANCE, QUALITY OR NON-INFRINGEMENT OF ANY INTELLECTUAL PROPERTY RIGHT; ALL SUCH WARRANTIES ARE HEREBY EXPRESSLY DISCLAIMED. SKYWORKS DOES NOT WARRANT THE ACCURACY OR COMPLETENESS OF THE INFORMATION, TEXT, GRAPHICS OR OTHER ITEMS CONTAINED WITHIN THESE MATERIALS. SKYWORKS SHALL NOT BE LIABLE FOR ANY DAMAGES, INCLUDING BUT NOT LIMITED TO ANY SPECIAL, INDIRECT, INCIDENTAL, STATUTORY, OR CONSEQUENTIAL DAMAGES, INCLUDING WITHOUT LIMITATION, LOST REVENUES OR LOST PROFITS THAT MAY RESULT FROM THE USE OF THE MATERIALS OR INFORMATION, WHETHER OR NOT THE RECIPIENT OF MATERIALS HAS BEEN ADVISED OF THE POSSIBILITY OF SUCH DAMAGE.

Skyworks products are not intended for use in medical, lifesaving or life-sustaining applications, or other equipment in which the failure of the Skyworks products could lead to personal injury, death, physical or environmental damage. Skyworks customers using or selling Skyworks products for use in such applications do so at their own risk and agree to fully indemnify Skyworks for any damages resulting from such improper use or sale.

Customers are responsible for their products and applications using Skyworks products, which may deviate from published specifications as a result of design defects, errors, or operation of products outside of published parameters or design specifications. Customers should include design and operating safeguards to minimize these and other risks. Skyworks assumes no liability for applications assistance, customer product design, or damage to any equipment resulting from the use of Skyworks products outside of stated published specifications or parameters.

Skyworks, the Skyworks symbol, and "Breakthrough Simplicity" are trademarks or registered trademarks of Skyworks Solutions, Inc., in the United States and other countries. Third-party brands and names are for identification purposes only, and are the property of their respective owners. Additional information, including relevant terms and conditions, posted at [www.skyworksinc.com](http://www.skyworksinc.com), are incorporated by reference.