

APPLICATION MANUAL

(The IC for one cell operation. Suitable for pager etc.)

TK 1 4 5 9 2 V

Features

- Low Voltage Operation 1.1V~
- Ceramics Discriminafor is usable.
- FSK comparator with Quick Charge Function it involves.
- RSSI circuit. RSSI beginning point is adjustable by varied external resistor.
- Very Small Package (TSSOP20)

※ Please note that the content of this application manual is subject to change without notice.

Please inquire us about this data.

- Semiconductor Sales and Marketing Department
1-17, Higashi-yukigaya 2-chome, Ohta-ku, Tokyo, 145 Japan
Tel : +81. 3. 3727-1171 Fax : +81. 3. 3727-1179
- Semiconductor Department Engineering Division
18, Gomigaya, tsurugashima-shi, Saitama, 350-02 Japan
Tel : +81. 492. 79-1661 Fax : +81. 492. 79-1861

TOKO Inc.	TOKO P/No. TK 1 4 5 9 2 V	Drawing No. GC3 - C 0 2 0	1/13	REV A
-----------	------------------------------	------------------------------	------	----------

[6] ELECTRICAL CHARACTERISTICS

Operating Conditions : Ta=25°C、Vcc=1.3V、fin=455kHz、fm=400Hz、Mod=±4.5kHz

PARAMETER	SYMBOL	STANDARD			UNIT	CONDITIONS
		MIN	TYP	MAX		
Supply Current 1	Icc1	0.9	1.2	1.5	mA	Vcc=1.4V、None-input
Supply Current 2	Icc2		10	25	uA	Vcc=1.4V、PS=ON、None-input
IF						
Limiting Sense	Limit	13	19	25	dBuEMF	-3dB Point
Output Voltage	Vo	-29	-23	-18	dBm	80dBuEMF input
Signal to Noise Rate	S/N	45	60		dB	80dBuEMF input
DC Voltage at Output Terminal	VODC	0.8	0.92	1.05	V	80dBuEMF input
Battery Alarm						
Battery Alarm Sensing Voltage	VA	1.05	1.10	1.15	V	None-input
Battery Alarm Output High Level	VAH	Vcc-0.15	Vcc-0.05	Vcc	V	None-input Vcc=Battery AlarmON~0V
Battery Alarm Output Low Level	VAL	0.00	0.03	0.25	V	None-input Vcc=Battery AlarmOFF~4.5V
Regulator						
Regulator Output Voltage 1	VOR1	0.95	1.00	1.05	V	None-input Output port is not terminated
Regulator Output Voltage 2	VOR2	0.95	1.00	1.05	V	Non-input、IOUT=10mA
FSK-Comparator						
Comparator Output High Level	CLH	1.15	1.28	1.30	V	80dBuEMF input
Comparator Output Low Level	CLL	0.00	0.03	0.25	V	80dBuEMF input
Duty Ratio	DR	45	50	55	%	80dBuEMF input
Quick Charge Current	IQC	50	80	120	uA	None-input
RSSI						
RSSI Output Voltage 1	VRSSI1	0.00	0.05	0.20	V	15dBuEMF none-mod input
RSSI Output Voltage 2	VRSSI2	0.25	0.55	0.90	V	55dBuEMF none-mod input
RSSI Output Voltage 3	VRSSI3	0.60	0.95	1.30	V	95dBuEMF none-mod input

[7] -1 PIN DESCRIPTION[1-9]

PIN No.	SYMBOL	VOLTAGE	INTERNAL EQUIVALENT CIRCUIT	DESCRIPTION
1	GND	0.0V		Ground
2	Vcc	1.3V		Supply Voltage 1.1~4.5V
3	RSSI IN	1.3V		RSSI input. RSSI beginning point adjustable by varied the resistor connected input terminal.
4	IF IN	1.13V		Input of Limiter. Input Impedance is 1.5Kohms.
5	IF DECOUPLING	1.13V		IF decoupling. External 0.1uF capacitor connected to Vcc.
6	IF DECOUPLING	1.13V		
7	IF OUT	0.48V		Output of Limiter.
8	QUAD IN	1.3V		Quadrature turning coil or ceramic discriminator.
9	DET OUT	0.96V		Output of Quadrature Detector.

[7] -2 PIN LOCATION[10-16]

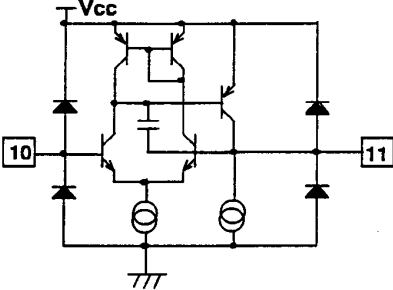
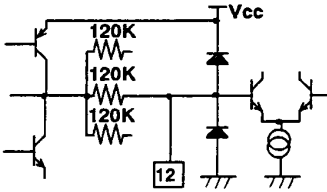
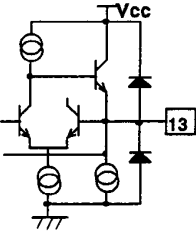
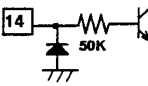
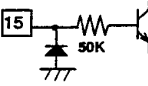
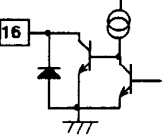
PIN No.	SYMBOL	VOLTAGE	INTERNAL EQUIVALENT CIRCUIT	DESCRIPTION
10 11	FILTER IN FILTER OUT	0.92V 0.94V		Filter amplifier for data shaping.
12	PRI SHAPING CAP	0.93V (QC-OFF) 0.92V (QC-ON)		Pri data shaping capacitor. 0.001uF capacitor value is recommend.
13	SHAPING CAP	0.92V (QC-OFF) 0.93V (QC-ON)		Data shaping capacitor. Time constant is 120Kohms × EXT-Capacitor.
14	QUICK CHARGE			Input of Quick Charge. When 1V added, Quick Charge on. Quick Charge Current is 80uA.
15	POWER SAVE			Input of Power Saving. When 1V added, Power Save on. Icc reduced down to 10uA. Wake up time ps-on to ps-off below 50ms.
16	FSK-OUT	Hi-level :1.3V Lo-level :0.03V		Output of FSK-Comparator. (open-collector output)

[7] -3 PIN DESCRIPTION[17-20]

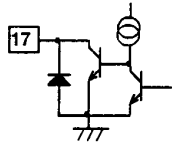
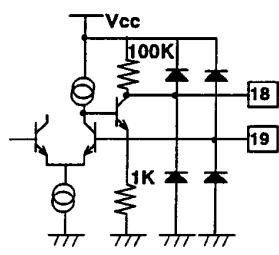
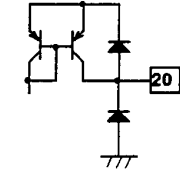
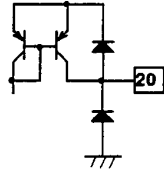
PIN No.	SYMBOL	VOLTAGE	INTERNAL EQUIVALENT CIRCUIT	DESCRIPTION
17	BATT-ALARM			Output of Battery Alarm. (open-collector output) Sense-Voltage is $1.1 \pm 0.05V$. Above sensing Voltage, output level is GND level. Bellow sensing Voltage, output level is Vcc level.
18	REG DRIVE	0.87V		Output of error amp for internal regulator. This pin drive EXT PNP TR. Output voltage is $1.0 \pm 0.05V$.
19	REG OUT	1.0V		Input of error amp for internal regulator.
20	RSSI OUT			Output of RSSI.

[8] -1 ELECTRICAL CHARACTERISTICS[1-6]

1. S+N+D,AMR,Noise,Distortion vs Vcc

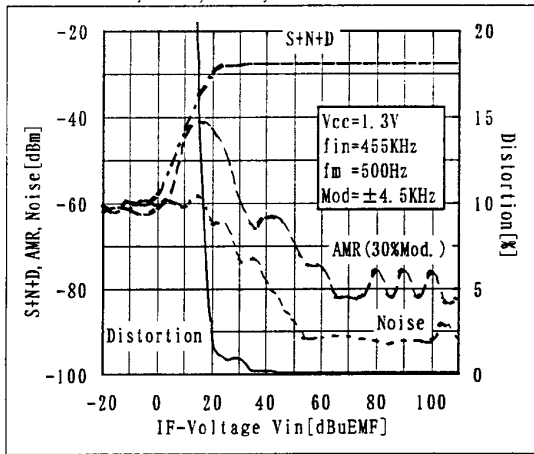

4. AF-Voltage vs Vcc

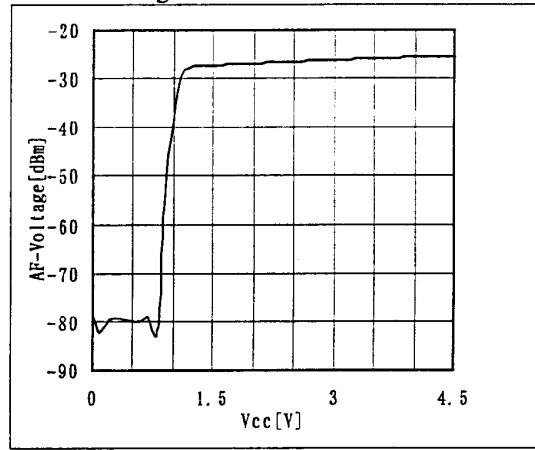

2. Battery Alarm vs Vcc

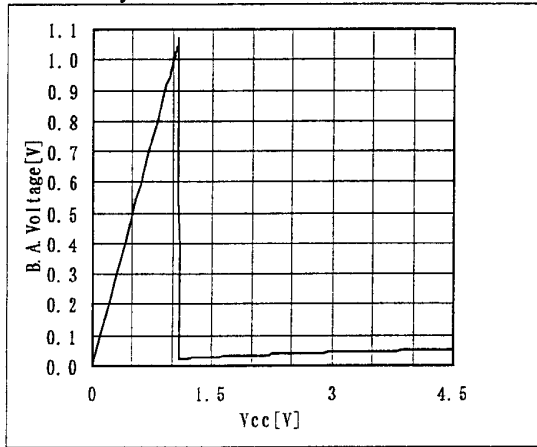

5. AF-Voltage, Distortion vs Mod. Frequency

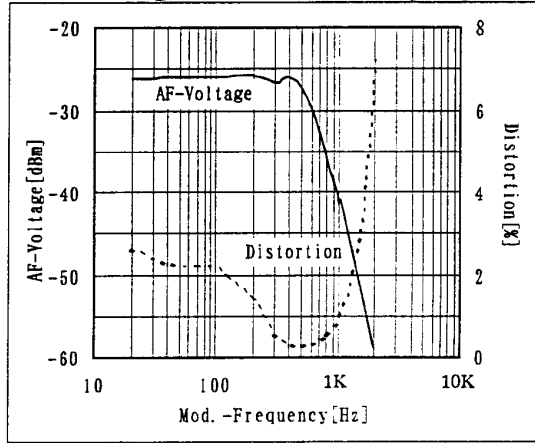

3. Regulator Output Voltage vs Vcc

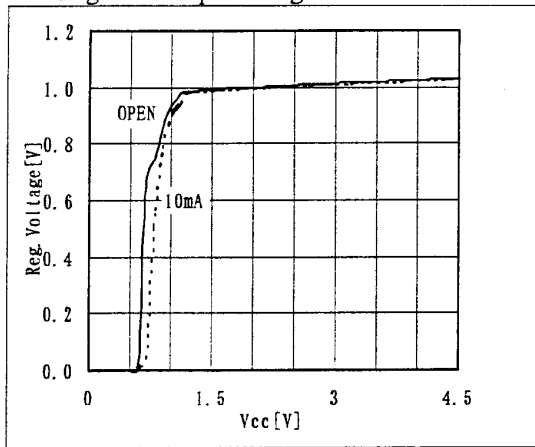

6. S/N Rate, AF-Voltage, Distortion vs Deviation

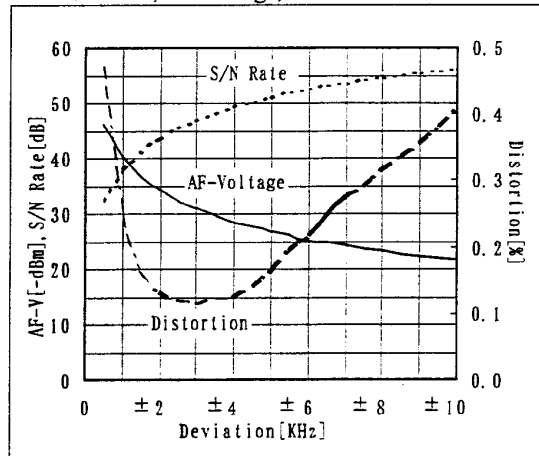

[8] -2 ELECTRICAL CHARACTERISTICS[7-12]

7. AF-Voltage,Distortion vs IF Input Frequency fin

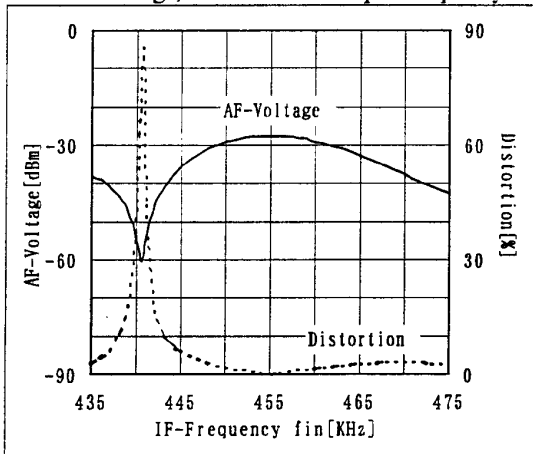

10. RSSI Voltage vs IF Input Voltage Vin

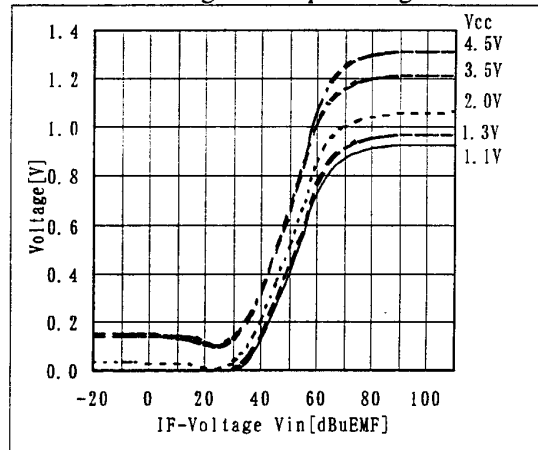

8. S-Curve Characteristics

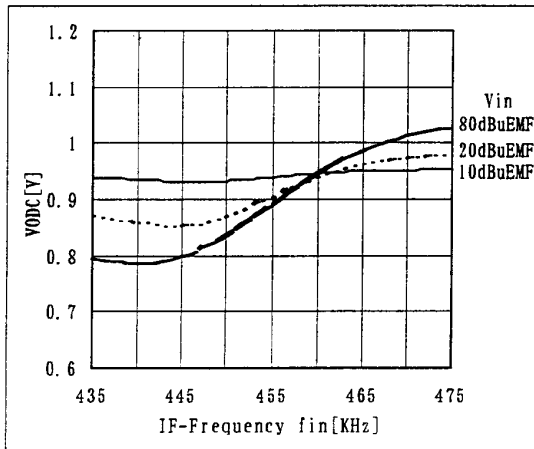

11. RSSI Output Voltage vs IF Input Voltage Vin

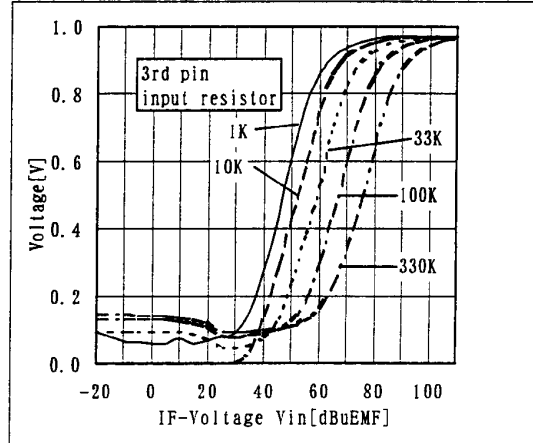

9. RSSI Output Current vs IF Input Voltage Vin

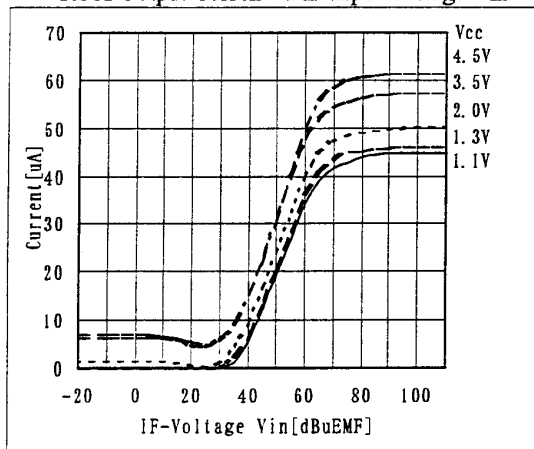

12. RSSI Output Voltage vs IF Input Voltage Vin

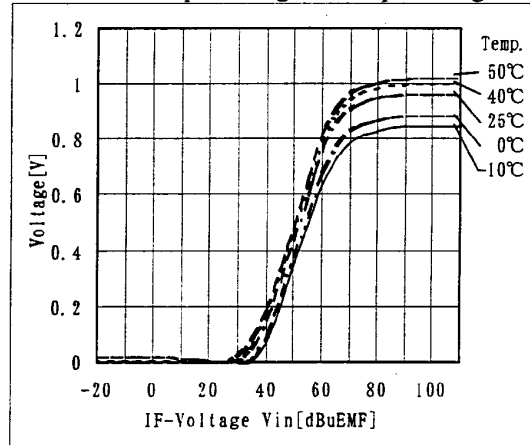

[8] -3 ELECTRICAL CHARACTERISTICS[13-18]

1 3. Detector AF-Voltage vs Temperature

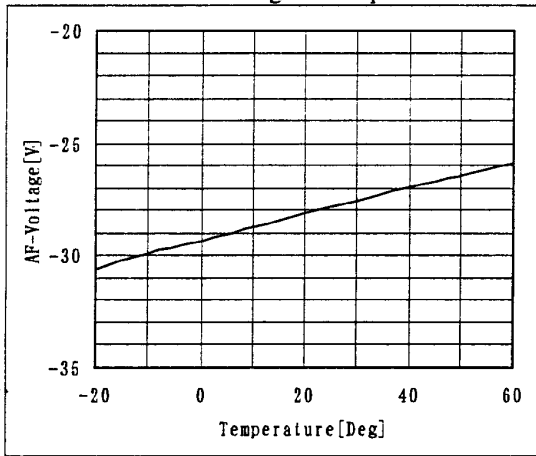

1 6. 12dB SINAD Sense vs Temperature

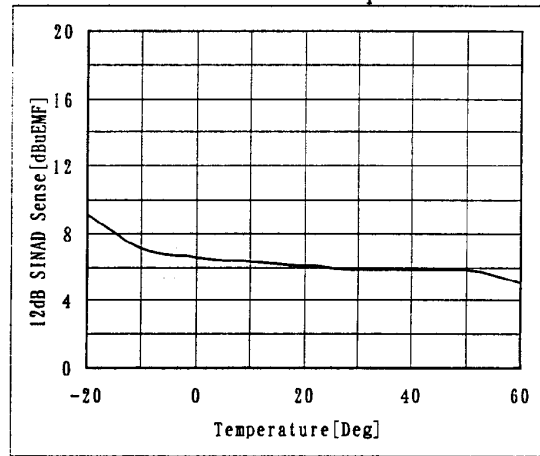

1 4. T.H.D. vs Temperature

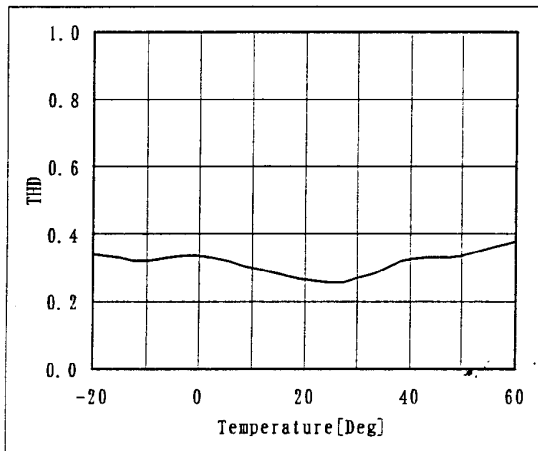

1 7. Detector DC Voltage at Output Terminal vs Temperature

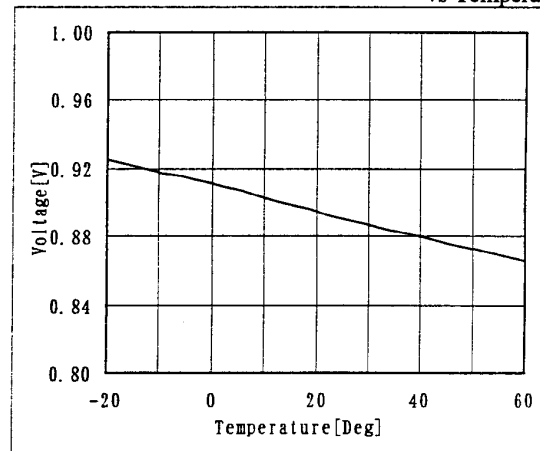

1 5. -3dB Limiting Sense vs Temperature

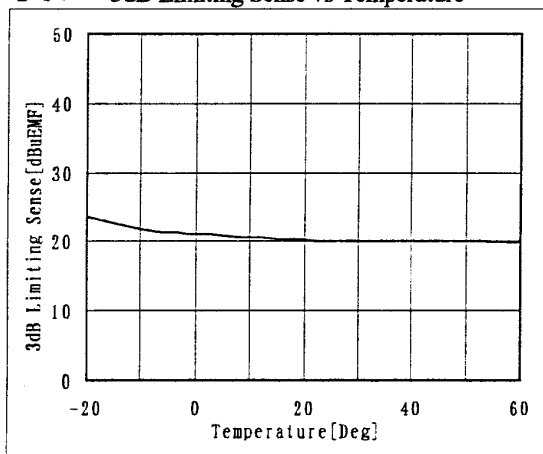

1 8. Icc vs Temperature

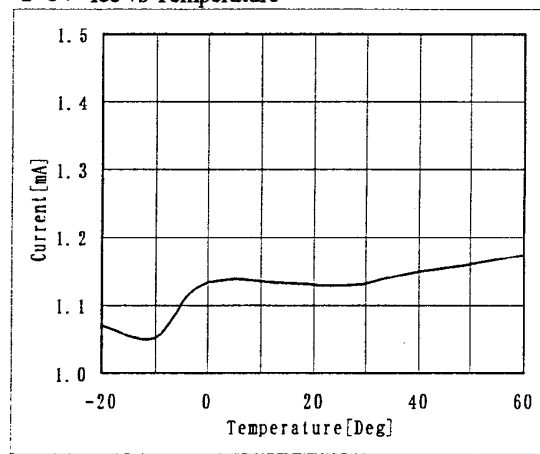

[8] -4 ELECTRICAL CHARACTERISTICS[19-22]

1 9. Regulator Voltage vs Temperature

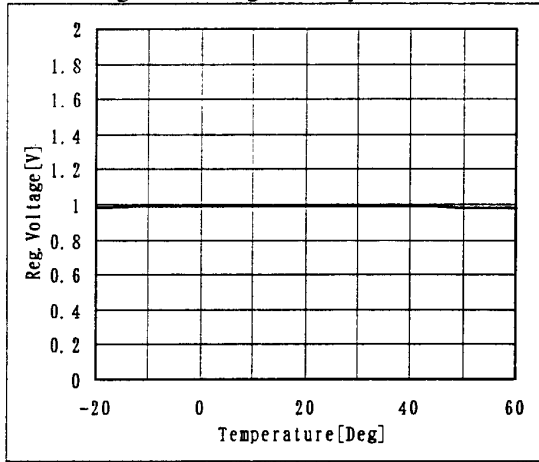

2 0. Battery Alarm Rise-Voltage vs Temperature

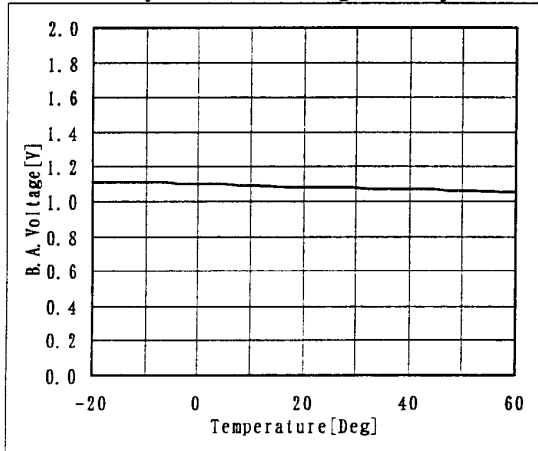

2 1. RSSI Output Voltage vs Temperature

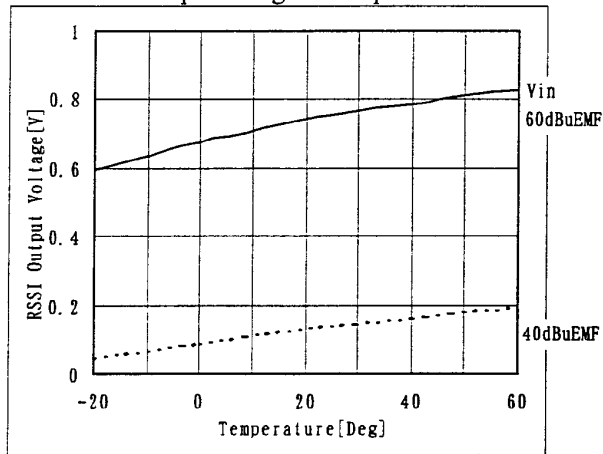

2 2. Icc1, Regulator Out, Duty Rate, S+N+D, -3dB Limiting Sensitivity vs Temperature

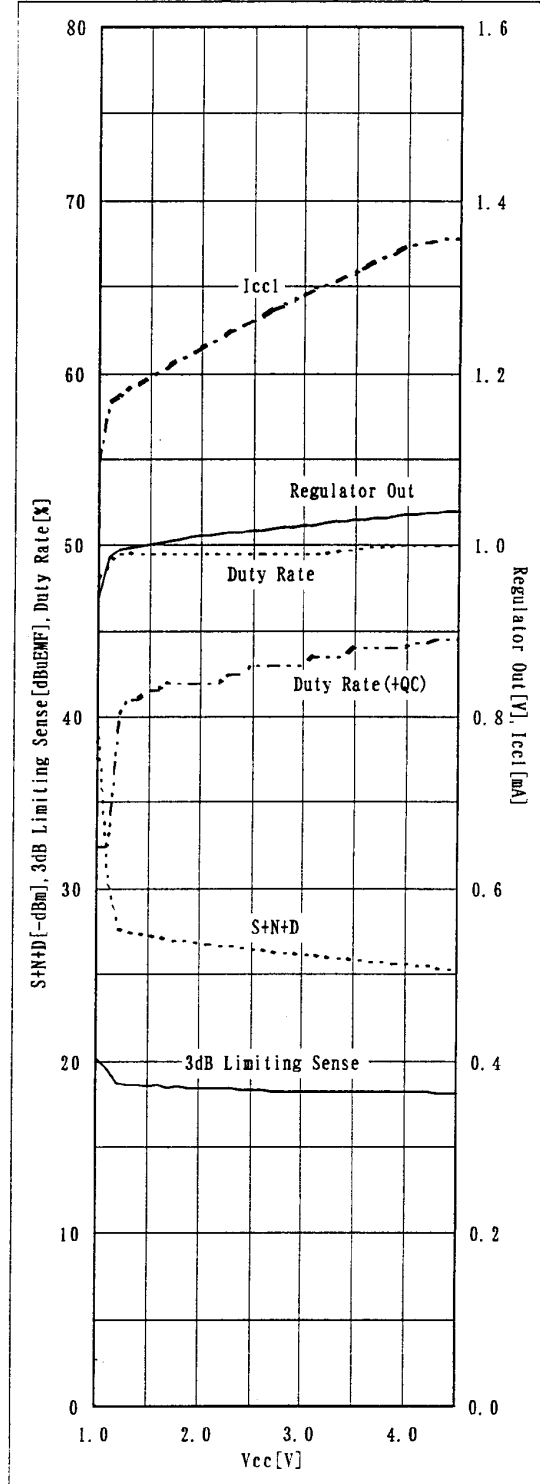

[9] PACKAGE OUTLINE DIMENSIONS/MARKING

・TSSOP20

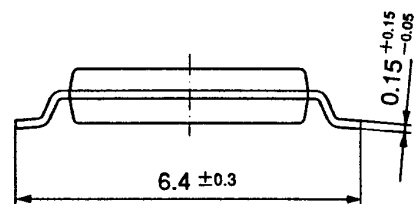
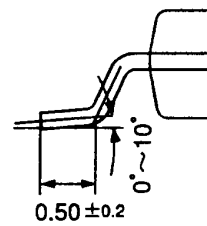
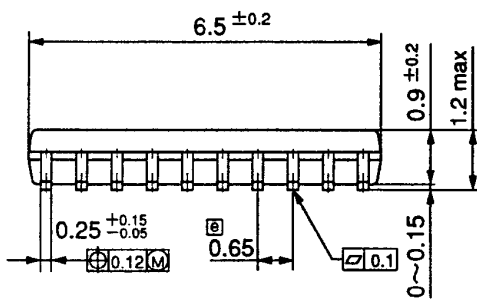
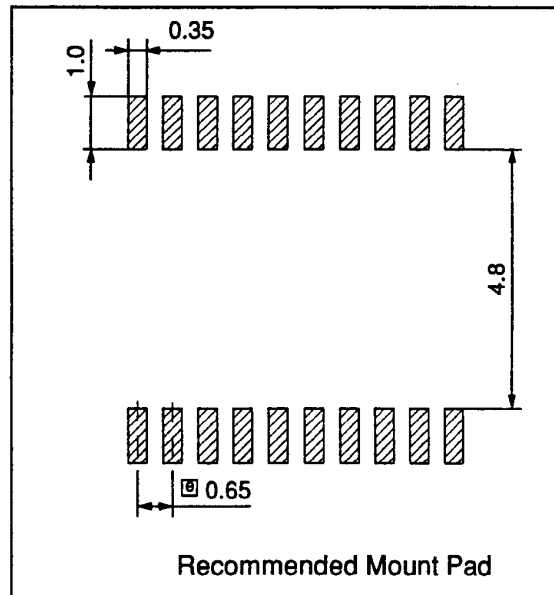
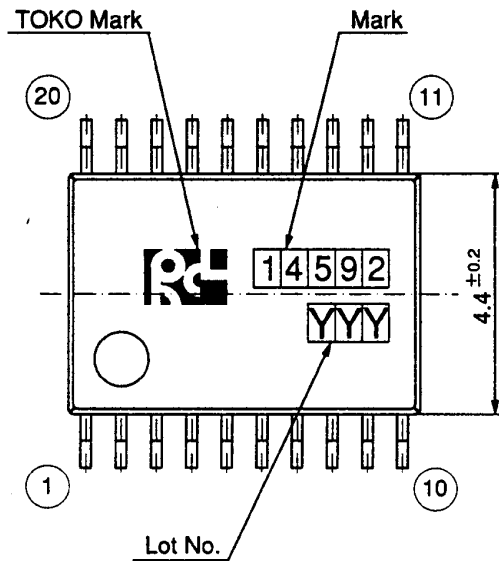

Scale : 8 / 1

Unit : mm

 General Tolerance : ± 0.2

Molded Resin : Epoxy Resin
 Lead Frame : Copper Alloy
 Terminal Treatment : Solder Plating
 Mark Method : Ink

【10】 TEST BOARD (SOLDER SIDE VIEW)

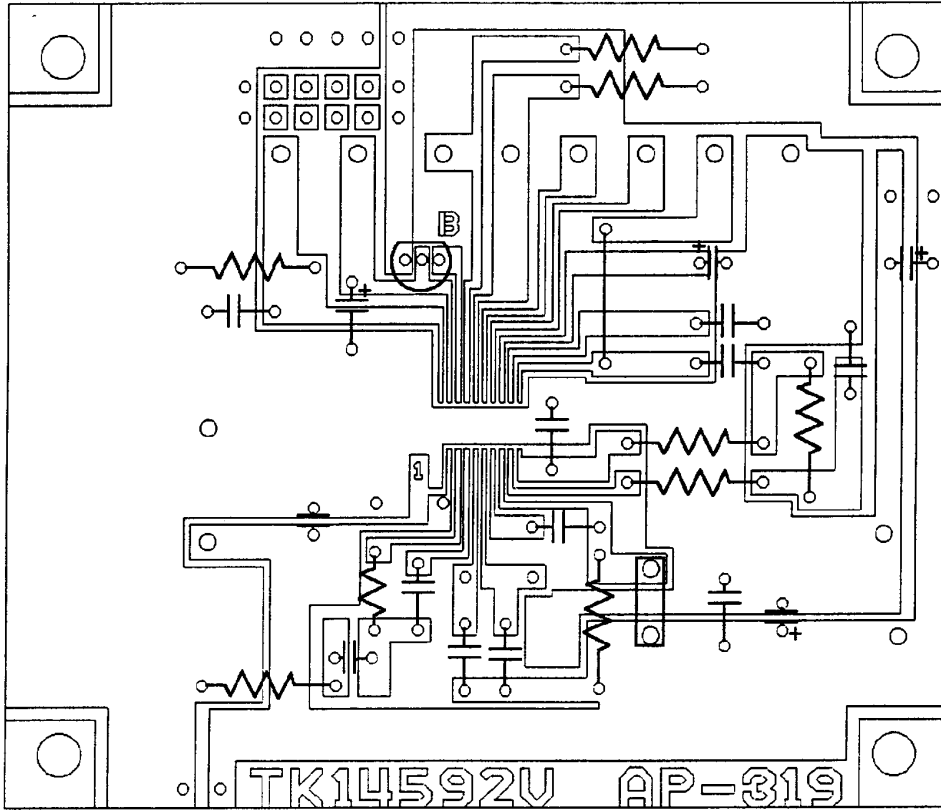

○ Additional Items

- 1) Examples of characteristics given here are typical for each product and begin technical data, these do not constitute a guarantee of characteristics or conditions of use.
The circuits shown in this application manual are intended to explain typical applications of the products concerned. Accordingly, TOKO is not responsible for any circuit problems, nor for any infringement of third party patents or any other intellectual property rights that may arise from the use of these circuits.
Moreover, this catalog does not signify that TOKO agrees implicitly or explicitly to license any patent rights or other intellectual rights which it holds.

- 2) Warning—Life Support Applications Policy
TOKO Inc. products shall not be used within any life support systems without the specific written consent of TOKO Inc. A life support system is a product of system intended to support or sustain life which, if it fails, can be reasonably expected result in a significant personal injury or death.

TOKO Inc.	TOKO P/No. TK14592V	Drawing No. GC3 - C020	13/13.	REV. A
-----------	------------------------	---------------------------	--------	-----------