

SDC2UV7282(A)-(67/84/100/125)T-S

16MByte (2M x 72) CMOS

Synchronous DRAM Module - ECC

General Description

The SDC2UV7282(A)-(67/84/100/125)T-S is a high performance, 16-megabyte synchronous, dynamic RAM module organized as 2M words by 72 bits, in a 168-pin, JEDEC ECC Configuration, dual-in-line memory module (DIMM) package.

The module utilizes nine Fujitsu MB81117822A-(67/84/100/125) PFTN CMOS 2Mx8 synchronous dynamic RAMs in surface mount package (TSOP) on an epoxy laminated substrate. Each device is accompanied by a decoupling capacitor for improved noise immunity.

A 256 Byte Serial EEPROM contains the module configuration information.

Features

- High Density: 16MByte
- Cycle Time: 8ns (125MHz), 10ns (100MHz), 12ns (84MHz), 15ns (67MHz)
- Low Power: Active 4.9W (125MHz), 4.4W (100MHz), 4.1W (84MHz), 3.7W (67MHz)
- LVTTTL-compatible inputs and outputs
- Separate power and ground planes to improve noise immunity
- Single power supply of 3.3V±0.3V
- Height: 1.250 inch (SDC2UV7282)
1.150 inch (SDC2UV7282A)

ABSOLUTE MAXIMUM RATINGS

Item	Symbol	Ratings	Unit
Voltage on any pin relative to V_{SS}	V_T	-0.5 to +4.6	V
Power Dissipation	P_T	11.7	W
Operating Temperature	T_{opr}	0 to +70	°C
Storage Temperature	T_{stg}	-55 to +125	°C
Short Circuit Output Current	I_{OS}	±50	mA

RECOMMENDED DC OPERATING CONDITIONS

($T_A = 0$ to +70 °C)

Symbol	Parameter	Min	Typ	Max	Unit
V_{CC}	Supply Voltage	3.0	3.3	3.6	V
V_{SS}	Ground	0	0	0	V
V_{IH}	Input High voltage	2.0	-	$V_{CC}+0.5$	V
V_{IL}	Input Low voltage	-0.5	-	0.8	V

SDC2UV7282(A)-(67/84/100/125)T-S

Functional Diagram

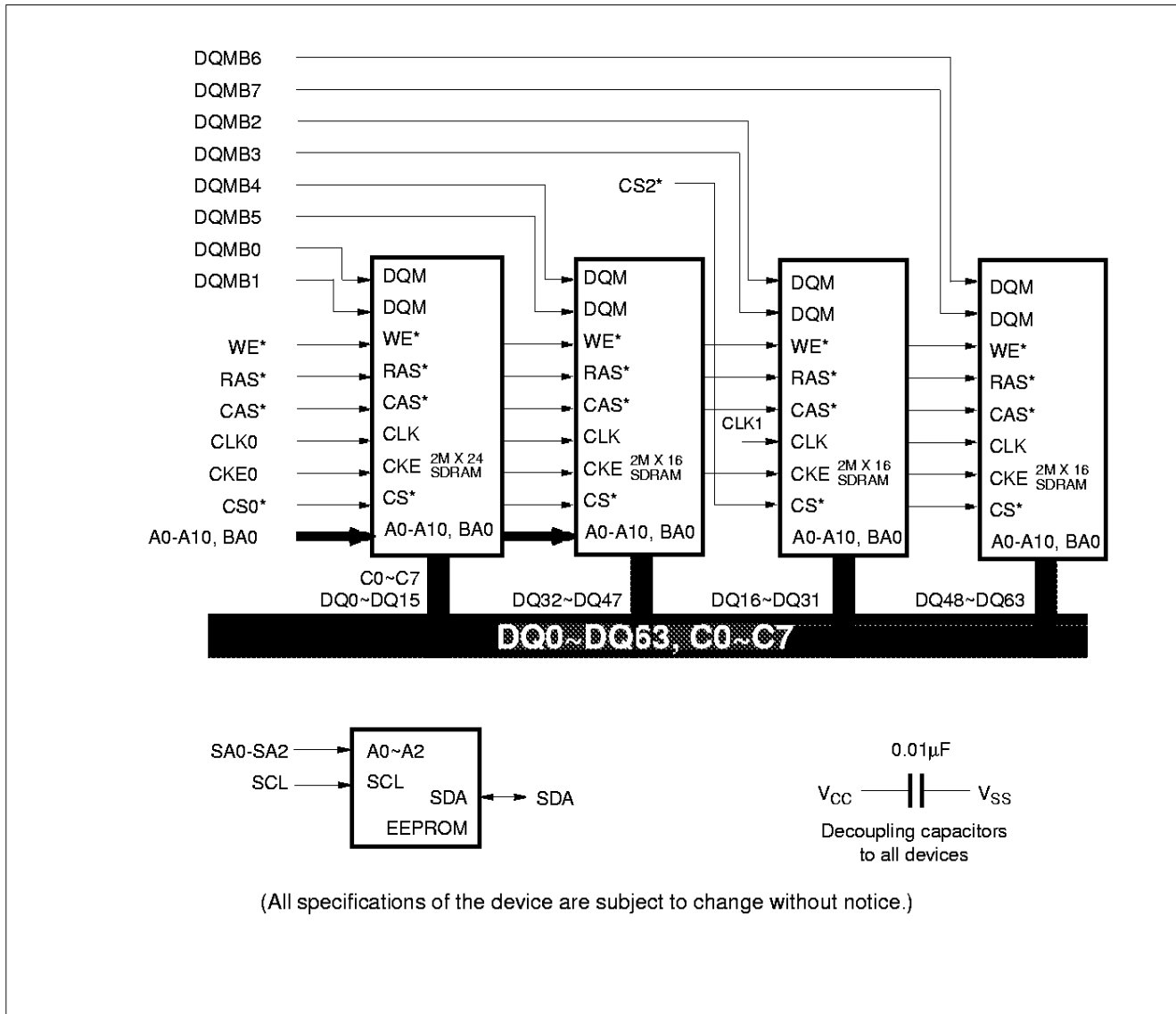

- Notes:
1. Data and CLKs are terminated using 10 ohm series resistors.
 2. Each 2Mx16 block comprises two 2Mx8 devices
 3. The 2Mx24 block comprises three 2Mx8 devices.
 4. DQMs vs Data I/Os

DQMB0 controls	DQ0 ~ DQ7
DQMB1 controls	DQ8 ~ DQ15, C0~C7
DQMB2 controls	DQ16 ~ DQ23
DQMB3 controls	DQ24 ~ DQ31
DQMB4 controls	DQ32 ~ DQ39
DQMB5 controls	DQ40 ~ DQ47
DQMB6 controls	DQ48 ~ DQ55
DQMB7 controls	DQ56 ~ DQ63
 5. Clock wiring

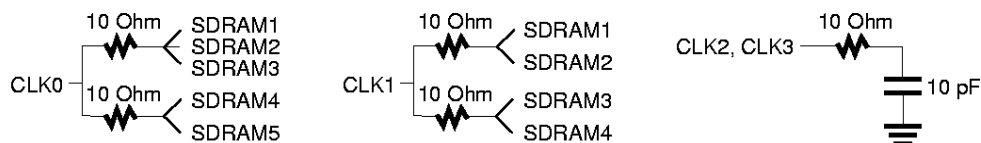

SDC2UV7282(A)-(67/84/100/125)T-S

Pin Name

A0~A10/AP	Addresses	CS0*, CS2*	Chip Select
BA0	Bank Select Address	WE*	Write Enable
DQ0~DQ63, C0~C7	Data Inputs/Outputs	SA0-SA2	Decode Input
CLK0~CLK3	Clock Inputs	SCL	Serial Clock
RAS*	Row Address Strokes	SDA	Serial Data Input/Output
CAS*	Column Address Strokes	V _{CC}	Power Supply
CKE0	Clock Enables	V _{SS}	Ground
DQMB0-DQMB7	DQ Mask Enables	NC	No Connection

Pin No.	Pin Designation	Pin No.	Pin Designation	Pin No.	Pin Designation	Pin No.	Pin Designation
1	V _{SS}	43	V _{SS}	85	V _{SS}	127	V _{SS}
2	DQ0	44	NC	86	DQ32	128	CKE0
3	DQ1	45	CS2*	87	DQ33	129	NC
4	DQ2	46	DQMB2	88	DQ34	130	DQMB6
5	DQ3	47	DQMB3	89	DQ35	131	DQMB7
6	V _{CC}	48	NC	90	V _{CC}	132	NC
7	DQ4	49	V _{CC}	91	DQ36	133	V _{CC}
8	DQ5	50	NC	92	DQ37	134	NC
9	DQ6	51	NC	93	DQ38	135	NC
10	DQ7	52	C2	94	DQ39	136	C6
11	DQ8	53	C3	95	DQ40	137	C7
12	V _{SS}	54	V _{SS}	96	V _{SS}	138	V _{SS}
13	DQ9	55	DQ16	97	DQ41	139	DQ48
14	DQ10	56	DQ17	98	DQ42	140	DQ49
15	DQ11	57	DQ18	99	DQ43	141	DQ50
16	DQ12	58	DQ19	100	DQ44	142	DQ51
17	DQ13	59	V _{CC}	101	DQ45	143	V _{CC}
18	V _{CC}	60	DQ20	102	V _{CC}	144	DQ52
19	DQ14	61	NC	103	DQ46	145	NC
20	DQ15	62	NC	104	DQ47	146	NC
21	C0	63	NC	105	C4	147	NC
22	C1	64	V _{SS}	106	C5	148	V _{SS}
23	V _{SS}	65	DQ21	107	V _{SS}	149	DQ53
24	NC	66	DQ22	108	NC	150	DQ54
25	NC	67	DQ23	109	NC	151	DQ55
26	V _{CC}	68	V _{SS}	110	V _{CC}	152	V _{SS}
27	WE*	69	DQ24	111	CAS*	153	DQ56
28	DQMB0	70	DQ25	112	DQMB4	154	DQ57
29	DQMB1	71	DQ26	113	DQMB5	155	DQ58
30	CS0*	72	DQ27	114	NC	156	DQ59
31	NC	73	V _{CC}	115	RAS*	157	V _{CC}
32	V _{SS}	74	DQ28	116	V _{SS}	158	DQ60
33	A0	75	DQ29	117	A1	159	DQ61
34	A2	76	DQ30	118	A3	160	DQ62
35	A4	77	DQ31	119	A5	161	DQ63
36	A6	78	V _{SS}	120	A7	162	V _{SS}
37	A8	79	CLK2	121	A9	163	CLK3
38	A10/AP (Note)	80	NC	122	BA0 (Note)	164	NC
39	NC	81	NC	123	NC	165	SA0
40	V _{CC}	82	SDA	124	V _{CC}	166	SA1
41	V _{CC}	83	SCL	125	CLK1	167	SA2
42	CLK0	84	V _{CC}	126	NC	168	V _{CC}

- Notes:
1. Address A10/AP : Initiates Auto-Precharge
 2. Address BA0 : Bank select within the SDRAM devices.

SDC2UV7282(A)-(67/84/100/125)T-S

SERIAL PD INFORMATION

Byte#	Function Described	Function Supported	Hex Value
0	# Bytes Written into serial memory at module mfr	128 bytes	80h
1	Total # bytes of SPD memory device	256 bytes	08h
2	Fundamental memory type	SDRAM	04h
3	# Row Address on this assembly	11	0Bh
4	# Column Addresses on this assembly	9	09h
5	# Module Banks on this assembly	1	01h
6	Data Width of this assembly	72 bits	48h
7	Data Width of this assembly (continued)		00h
8	Voltage interface standard of this assembly	LVTTTL	01h
9	SDRAM cycle time at CL=3 (tCLK)	8ns	80h
		10ns	A0h
		12ns	C0h
		15ns	F0h
10	SDRAM Access from Clock at CL=3 (tAC)	7.5ns	75h
		8.5ns	85h
		8.5ns	85h
		9.0ns	90h
11	DIMM configuration type	ECC	02h
12	Refresh Rate/Type	S/R, Normal 15.6 μ s	80h
13	SDRAM Width Primary DRAM	x8	08h
14	ECC SDRAM Data Width	x8	08h
15	Min. clock delay, Back to Back Random Column Addresses (ICCD)	1CLK	01h
16	Burst Length Supported	1, 2, 4, 8 & Full	8Fh
17	# Banks on each SDRAM device	2	02h
18	CAS# Latency	2, 3	06h
19	CS# Latency	0	01h
20	Write Latency	0	01h
21	SDRAM Module Attribute	Non-Buffered/Registered	00h
22	SDRAM Device Attribute	Vcc, B/R, S/W, P/A, A/P	0Eh
23	Min Clock cycle Time at CL=2 (tCLK)	12ns	C0h
		15ns	F0h
		17ns	20h
24	Max. Data Access Time from clock at CL=2 (tAC)	9.0ns	90h
		9.0ns	90h
		9.0ns	90h
		10.0ns	A0h
25	Min Clock cycle Time at CL=1 (tCLK)	N/A	00h
26	Max. Data Access Time from clock at CL=1 (tAC)	N/A	00h
27	Min. Row Precharge Time (tRP)	27ns	1Bh
		30ns	1Eh
		35ns	23h
		40ns	28h
28	Min. Row Active Delay (tRRD)	24ns	18h
		30ns	1Eh
		30ns	1Eh
		30ns	1Eh
29	Min. RAS to CAS Delay (tRCD)	24ns	18h
		30ns	1Eh
		30ns	1Eh
		30ns	1Eh
30	Min. RAS Pulse Width (tRAS)	48ns	30h
		60ns	3Ch
		65ns	41h
		70ns	46h
31	Module Bank Density	16MB	04h
32-61	Superset Information		00h
62	SPD Revision	Rev. 1	01h
63	Checksum for bytes 0-62		
64-127	Manufacturer's Information		
128+	Unused Storage Locations		

SDC2UV7282(A)-(67/84/100/125)T-S

DC CHARACTERISTICS

($V_{CC} = 3.3V \pm 0.3V$, $V_{SS} = 0V$, $T_A = 0$ to $+70^\circ$)

Parameter	Symbol	Test Condition	125		100		84		67		Unit	Note
			Min.	Max.	Min.	Max.	Min.	Max.	Min.	Max.		
Operating Current	I_{CC1}	No Burst, $t_{CK} = \text{min.}$ $t_{RC} = \text{min.}$	-	810	-	765	-	720	-	675	mA	1, 2
		No Burst, $t_{CK} = \text{min.}$, $t_{RC} = \text{min.}$ All Banks Active	-	1120	-	1040	-	960	-	880	mA	1, 2
Precharge Standby Current	I_{CC2}	CKE - V_{IL} , $t_{CK} = \text{min.}$ All Banks Idle	-	18	-	18	-	18	-	18	mA	1, 2
		CKE = V_{IH} , $t_{CK} = \text{min.}$ All Banks Idle	-	270	-	270	-	270	-	270	mA	1, 2
Active Standby Current	I_{CC3}	CKE = V_{IL} , $t_{CK} = \text{min.}$ Any Bank Active	-	270	-	270	-	270	-	270	mA	1, 2
		CKE = V_{IH} , $t_{CK} = \text{min.}$ Any Bank Active	-	450	-	450	-	450	-	450	mA	1, 2
Burst Mode Current	I_{CC4}	$t_{CK} = \text{min.}$	-	1350	-	1215	-	1125	-	1025	mA	1, 2
Refresh Current	I_{CC5}	$t_{CK} = \text{min.}$, $t_{RC} = \text{min.}$, $t_{RRD} = \text{min.}$ Auto Refresh	-	1080	-	990	-	900	-	810	mA	1, 2
Self Refresh Current	I_{CC6}	CKE - V_{IL}	-	18	-	18	-	18	-	18	mA	1, 2
Input Leakage	I_{LI}	$0V \leq V_{in} \leq V_{CC}$	-90	90	-90	90	-90	90	-90	90	μA	
Output Leakage Current	I_{LO}	$0V \leq V_{out} \leq V_{CC}$ $D_{out} = \text{Disable}$	-10	10	-10	10	-10	10	-10	10	μA	
Output High Voltage	V_{OH}	High $I_{out} = -2mA$	2.4	-	2.4	-	2.4	-	2.4	-	V	
Output Low Voltage	V_{OL}	Low $I_{out} = 2 mA$	-	0.4	-	0.4	-	0.4	-	0.4	V	

†CL = CAS* Latency

- Notes:
- I_{CC} depends on output load condition when the device is selected $I_{CC} (\text{max.})$ is specified at the output open condition.
 - An initial pulse of 200 μs is required after power-up followed by a minimum of eight Auto-Refresh-Cycles.

CAPACITANCE

($T_A = +25^\circ C$, $V_{CC} = 3.3V \pm 0.3V$)

Parameter	Symbol	Max.	Unit	Note
Input Capacitance (Address, WE*, CKE, RAS*, CAS*)	C_{I1}	46	pF	1
Input Capacitance (DQMB0, DQMB2~DQMB7)	C_{I2}	14	pF	1
Input Capacitance (DQMB1)	C_{I3}	18	pF	1
Input Capacitance (CS0*, CLK0)	C_{I4}	30	pF	1
Input Capacitance (CS2*, CLK1)	C_{I5}	26	pF	1
Input Capacitance (CLK2, CLK3)	C_{I6}	15	pF	1
Input/Output Capacitance (DQ0~DQ63, C0~C7)	$C_{I/O}$	17	pF	1, 2

- Notes:
- Capacitance is measured with Boonton Meter or effective capacitance method.
 - CAS* - V_{IH} to disable D_{out} .

SDC2UV7282(A)-(67/84/100/125)T-S

AC CHARACTERISTICS

(TA = 0 to +70°C, V_{CC} = 3.3V±0.3V, V_{SS} = 0V)

Parameter		Symbol	Unit	125		100		84		67		Notes
Clock Period	CL=3	t _{CLK}	ns	8	-	10	-	12	-	15	-	1, 2, 3, 6
	CL=2			12	-	15	-	17	-	20	-	
Transition Time		t _T	ns	0.5	2	0.5	2	0.5	2	0.5	2	1, 2, 3
Clock High Time		t _{CH}	ns	3.5	-	4	-	4	-	4	-	1, 2, 3
Clock Low Time		t _{CL}	ns	3.5	-	4	-	4	-	4	-	1, 2, 3
CS Setup Time		t _{SC}	ns	3.0	-	3.0	-	3.0	-	3.0	-	1, 2, 3
CS Hold Time		t _{HC}	ns	1.0	-	1.0	-	1.0	-	1.0	-	1, 2, 3
Input Setup Time		t _{SI}	ns	3.0	-	3.0	-	3.0	-	3.0	-	1, 2, 3
Input Hold Time		t _{HI}	ns	1.0	-	1.0	-	1.0	-	1.0	-	1, 2, 3
Output Valid from Clock	CL=3	t _{AC}	ns	-	7.5	-	8.5	-	8.5	-	9.0	1, 2, 3
	CL=2			-	9	-	9	-	9	-	10	
Output In Low-Z		t _{OLZ}	ns	2	-	3	-	3	-	3	-	1, 2, 3
Output in High-Z		t _{OHZ}	ns	2	-	3	-	3	-	3	-	1, 2, 3, 4
Output Hold Time		t _{OH}	ns	2	-	3	-	3	-	3	-	1, 2, 3
Time between Refresh		t _{REF}	ms	-	32.8	-	32.8	-	32.8	-	32.8	1, 2, 3
RAS Cycle Time		t _{RC}	ns	75	-	90	-	100	-	110	2	1, 2, 3, 5
RAS Access Time		t _{RAC}	ns	-	45	-	54	-	56	-	60	1, 2, 3
CAS Access Time		t _{CAC}	ns	-	21	-	24	-	26	-	30	1, 2, 3
RAS Precharge Time		t _{RP}	ns	27	-	30	-	35	-	40	-	1, 2, 3
RAS Active Time		t _{RAS}	ns	48	10000	60	10000	65	-	70	10000	1, 2, 3
RAS to CAS Delay Time		t _{RCD}	ns	24	-	30	-	30	-	30	-	1, 2, 3
Write Recovery Time		t _{WR}	ns	8	-	10	-	12	-	15	-	1, 2, 3
Write to Precharge Lead Time		t _{RWL}	ns	8	-	10	-	12	-	15	-	1, 2, 3
RAS to RAS Delay Time		t _{RRD}	ns	24	-	30	-	30	-	30	-	1, 2, 3
Power-down Exit Time		t _{PDE}	ns	3	-	3	-	4	-	5	-	1, 2, 3
CKE to Clock Disable		t _{CKE}	cycle	1		1		1		1		
DQM to Output in High-Z		t _{DQZ}	cycle	2		2		2		2		
DQM to Input Data Delay		t _{DQD}	cycle	0		0		0		0		
Last Output to Write Command Delay		t _{OWD}	cycle	2		2		2		2		
Write Command to Input Data Delay		t _{DWD}	cycle	0		0		0		0		
Precharge to Output in High-Z Delay	CL=3	t _{ROH}	cycle	3		3		3		3		
	CL=2			2		2		2		2		
Mode Register Access to Bank Active (min.)		t _{MRD}	cycle	2		2		2		2		
CAS to CAS Delay		t _{CCD}	cycle	1		1		1		1		
CAS Bank Delay		t _{CBD}	cycle	1		1		1		1		

- Notes:
1. An initial pulse of at least 200μs is required after power-up followed by a minimum of eight auto refresh cycles.
 2. AC characteristics assume t_T = 1 ns and 50pF capacitive load. If t_T is longer than 1 ms, reference level for measuring time of input signal is V_{IH} (min.) and V_{IL} (max.).
 3. 1.4V is the reference level for measuring timing of input signals.
 4. t_{HZ} and t_{OH} defines the time at which the outputs achieve ±200mV.
 5. Actual clock output of t_{RC} will be sum clock of t_{RAS} and t_{RP}
 6. 20ns is not supported in SPD.

SDC2UV7282(A)-(67/84/100/125)T-S

Physical Dimensions

168-pin (84x2) DIMM

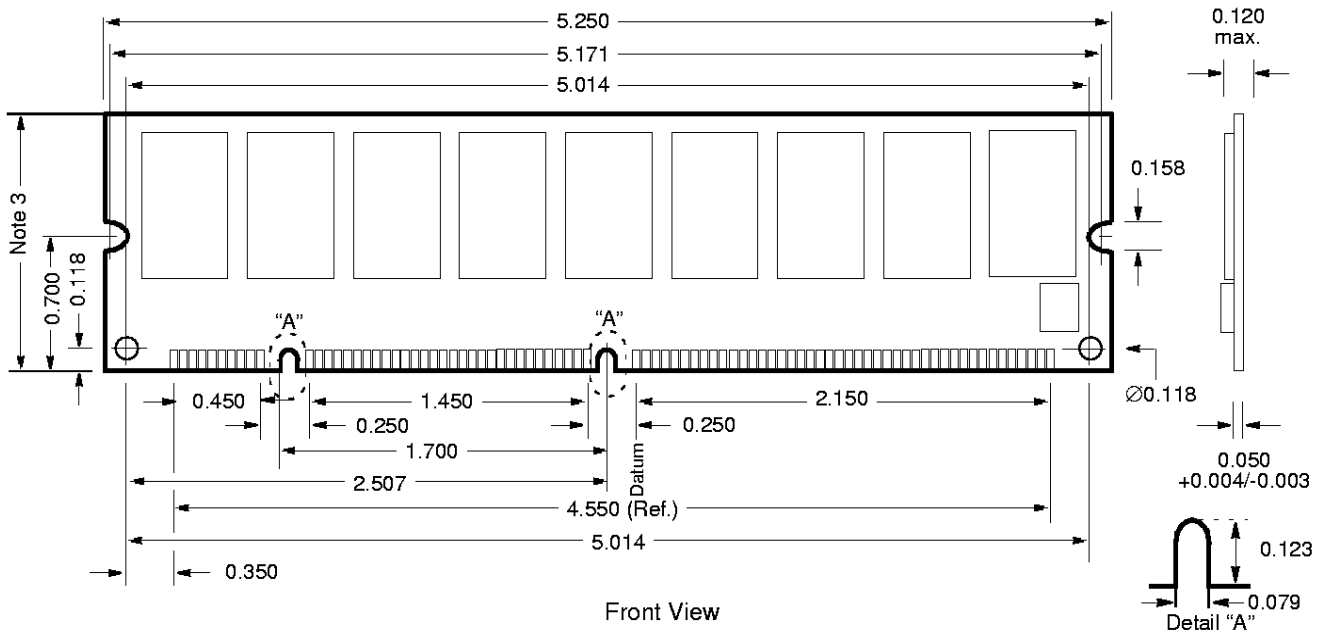

- Notes:
1. All dimensions are in inches.
 2. Pin 85 is behind pin 1 on the back side.
 3. 1.250 (SDC2UV7282)
1.150 (SDC2UV7282A)

Worldwide Headquarters

Japan

Tel: +81 44 754 3753
Fax: +81 44 754 3332

Fujitsu Limited

1015 Kamiodanaka
Nakaharaku
Kawasaki 211
Japan

<http://www.fujitsu.co.jp/>

Asia

Tel: +65 281 0770
Fax: +65 281 0220

Fujitsu Microelectronics Asia PTE Limited

#05-08, 151 Lorong Chuan
New Tech Park
Singapore 556741

<http://www.fsl.com.sg/>

USA

Tel: +1 408 922 9000
Fax: +1 408 922 9179

Fujitsu Microelectronics Inc
3545 North First Street
San José CA 95134-1804
USA

Tel: +1 800 866 8608
Fax: +1 408 922 9179

Customer Response Center
Mon-Fri: 7am-5pm (PST)

<http://www.fujitsumicro.com/>

Europe

Tel: +49 6103 6900
Fax: +49 6103 6901

Fujitsu Mikroelektronik GmbH

Am Siebenstein 6-10
D-63303 Dreieich-
Buchschlag
Germany

<http://www.fujitsu.ede.com/>

All Right Reserved.

The information contained in this document has been carefully checked and is believed to be reliable. However, Fujitsu Microelectronics, Inc. assumes no responsibility for inaccuracies.

The information conveyed in this document does not convey any license under the copyrights, patent rights or trademarks claimed and owned by Fujitsu Limited, its subsidiaries, or Fujitsu Microelectronics, Inc.

Fujitsu Microelectronics, Inc. reserves the right to change products or specifications without notice.

No part of the publication may be copied or reproduced in any form or by any means, or transferred to any third party without prior written consent of Fujitsu Microelectronics, Inc.

MP-SDRAMM-DS-20368-3/97