

# Reed Switch Databook

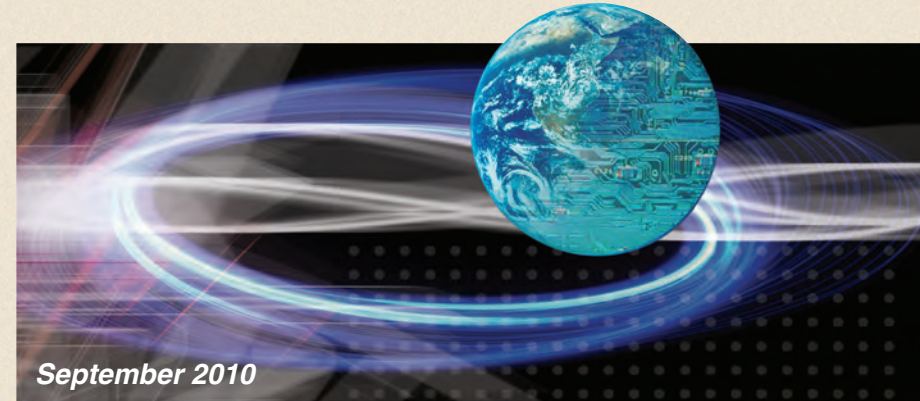

OKI Sensor Device — Reed Switch Databook 2010 —

**OKI**

**Oki Sensor Device Corporation**

Tachihi Bldg. #7 4F, 6-1-1 Sakae-cho, Tachikawa-shi, Tokyo 190-0003, Japan

Tel: +81-42-537-6563 Fax: +81-42-537-6586

<http://www.osdc.co.jp/>

For further information please contact:

---

## Preface

We would like to thank you for being a loyal user of our reed switch products. In the rapidly developing electronics industry, reed switch products span a wide field of applications that demand not only performance and function, but also compact size and high reliability. To meet these demands, we have developed a broad range of high-performance and high-reliability reed switches that find application in numerous fields.

This Databook provides all the necessary reed switch specifications required and we hope it will stand you in good stead.

Utilizing state-of-the-art technology, it is our firm commitment to contribute to the development of the electronics industry and would like to solicit your guidance and support in helping us reach this goal.

September 2010

Oki Sensor Device Corporation

---

## NOTICE

1. The specifications described in this databook were established in line with standard operating and measurement conditions for product. Therefore, when actually using product, perform circuit/mounting design taking into account mechanical characteristics and environmental characteristics.
2. When implementing design, please use product within guaranteed range for electrical characteristics, environmental characteristics, operating characteristics and service life characteristics, etc. Please be aware that Oki Sensor Device Corporation (hereinafter, OSDC) bears no responsibility for results attributable to use outside of the guaranteed range, or other mistaken or improper use of product.
3. When using product, information, drawings and other material described in this databook, OSDC does not provide any guarantees, or grant any licenses relating to the industrial property rights, intellectual property rights or other rights of third parties. Please be aware that OSDC will bear no responsibility for infringement of the rights of third parties due to such use.
4. Although OSDC persistently strives to improve quality and reliability of product, a certain probability of occurrence of defect and malfunction is unavoidable. In order to avoid situations where defect or malfunction of product directly threatens human life, or causes injury or property damage, please conduct adequate safety design for overall equipment or system when designing equipment or system incorporating product. Strict caution is particularly necessary for use in applications such as traffic equipment, safety equipment, aviation/space equipment, nuclear power control, or medical equipment containing life support equipment.
5. The information contained in this databook can change without prior notice or warning owing to product and/or technical improvement. Before using product, please make sure that the information being referred to is up-to-date.
6. Reproduction or copying of content in this databook without prior authorization from OSDC is strictly prohibited.
7. Although the utmost care has been taken to ensure accuracy of information herein, please feel free to contact the Sales and Marketing Department if any errors are detected.

Copyright 2010 Oki Sensor Device Corporation.

# MOLDED SWITCH

## RA-901

### Miniature SMD

#### ■ GENERAL DESCRIPTION

The RA-901 is a molded ORD228VL reed switch with processed leads. While boasting the excellent characteristics of the ORD228VL, the molded exterior ensures ease of handling.

#### ■ FEATURES

- (1) Gull wing shape leads for SMT applications
- (2) Automatic mounting of component by tape and reel
- (3) Enhanced shock resistance due to resin mold protecting the glass tube
- (4) General purpose miniature

#### ■ EXTERNAL DIMENSIONS (Unit: mm)

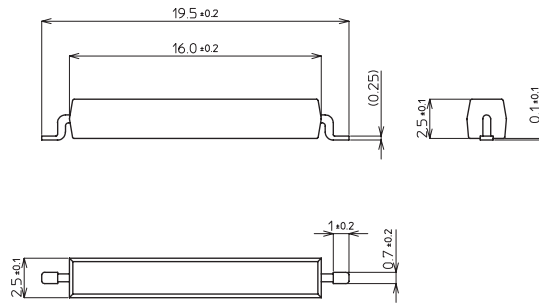

#### ■ PAD LAYOUT SAMPLE

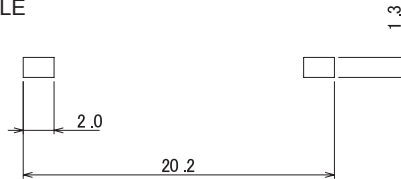

#### ■ APPLICATIONS

- Automotive electronic devices
- Control equipment
- Communication equipment
- Measurement equipment
- Household appliances

■ SPECIFICATION

Contact Form	1A
Pull-in Value (PI)	15~49AT
Drop-out Value (DO)	10AT (Min.)
Contact Resistance (CR)	100mΩ (Max.)
Contact Rating	10VA
Maximum Switching Voltage	100V DC/AC
Maximum Switching Current	0.5A
Maximum Carry Current	1.0A
Breakdown Voltage	200V (Min.)
Insulation Resistance	1×10 <sup>9</sup> Ω (Min.)
Operate Time	0.4ms (Max.)
Bounce Time	0.3ms (Max.)
Release Time	0.05ms (Max.)
Shock Resistance	490m/s <sup>2</sup> —11ms
Vibration Resistance	490m/s <sup>2</sup> (10~2000Hz)
Operating Temperature Range	-40~125°C
Storage Temperature Range	-50~125°C
Electrostatic Capacitance	0.3pF (Max.)
Resonant Frequency	5400Hz (typ)
Maximum Operating Frequency	500Hz

3

■ PULL-IN VALUE TABLE (After forming)

Model No.	1	2	3	4	5	6	7	8
Pull-in Value (AT)	15~34	18~36	19~39	21~42	24~45	27~49	30~49	34~49

■ Reflow Conditions

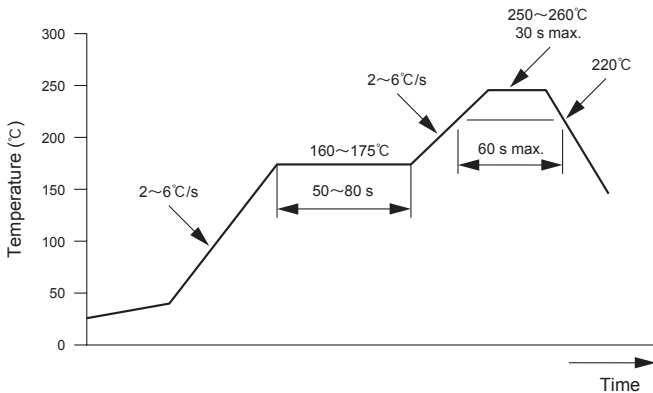

■ Magnet Drive Characteristics Example (1)

Magnet: 5 x 5 x 6 mm  
 Anisotropic barium ferrite  
 Surface magnetic flux 120 mT

Molded Switch: RA-901-1  
 Pull-in value 15.0 (AT)  
 Drop-out value 13.5 (AT)

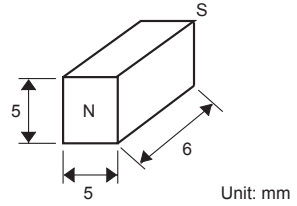

(1) X-Y Characteristic H

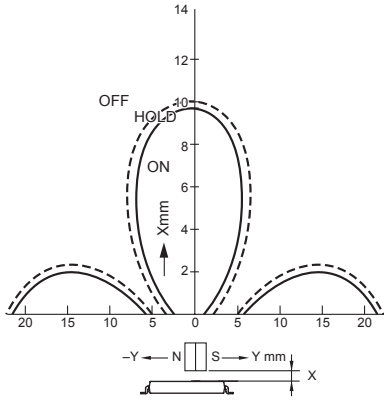

(2) X-Z Characteristic H

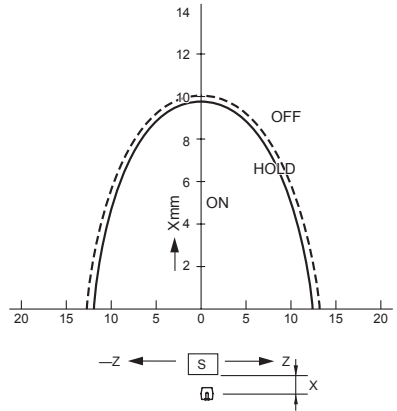

(3) X-Y Characteristic V

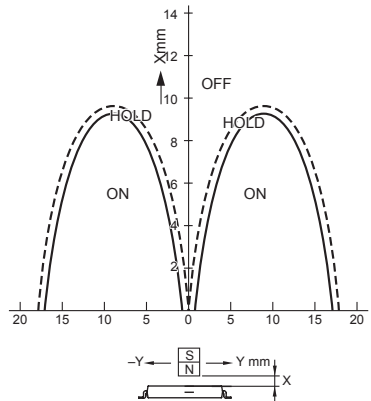

■ RA-901 Magnet Drive Characteristics Example (2)

Magnet: 5 x 5 x 6 mm  
 Anisotropic barium ferrite  
 Surface magnetic flux 120 mT

Molded Switch: RA-901-1  
 Pull-in value 34.0 (AT)  
 Drop-out value 29.1 (AT)

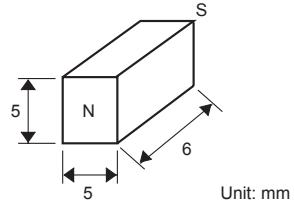

(1) X-Y Characteristic H

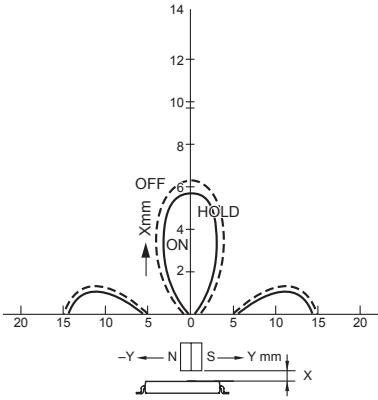

(2) X-Z Characteristic H

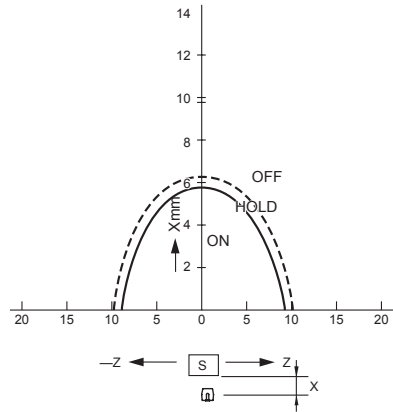

(3) X-Y Characteristic V

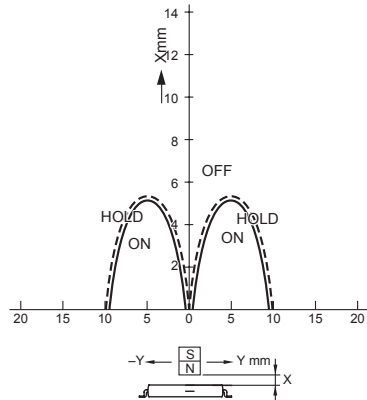

3