

FIBER OPTIC TRANSCEIVING MODULE

TODX270A

FIBER OPTIC TRANSCEIVING MODULE FOR
 DUPLEX DIGITAL SIGNAL COMMUNICATION

Unit in mm

- Data rate : DC to 6Mb/s (NRZ code)
- Transmission distance : Up to 40m
- TTL interface
- LED is driven by Differential circuit.
- ATC (Automatic Threshold Control) circuit is used for stabilized output at wide range of optical power level.

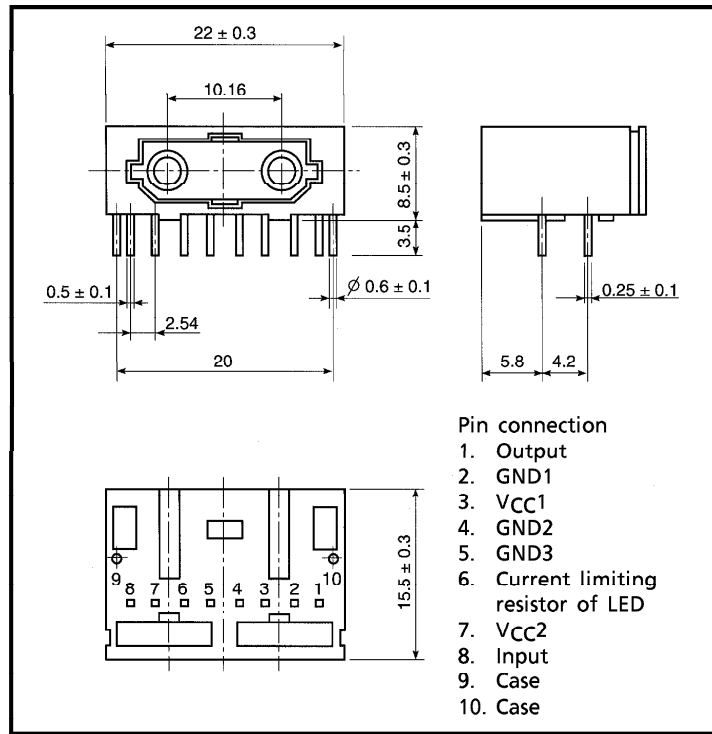

1. Maximum Ratings (Ta = 25°C)

ITEM	SYMBOL	RATING	UNIT
Storage Temperature	T _{stg}	-40 to 70	°C
Operating Temperature	T _{opr}	-40 to 70	°C
Supply Voltage	V _{CC}	-0.5 to 7	V
Input Voltage	V _{IN}	-0.5 to V _{CC} +0.5	V
Low Level Output Current	I _{OL}	20	mA
High Level Output Current	I _{OH}	-1	mA
Soldering Temperature	T _{sol}	260 ⁽¹⁾	°C

Note ⁽¹⁾ Soldering time ≤ 3 seconds (More than 1mm apart from package).

Handling precaution : The LEDs used in this product contain GaAs (Gallium Arsenide). Care must be taken to protect the safety of people and the environment when scrapping or terminal processing.

961001EAC2

- TOSHIBA is continually working to improve the quality and the reliability of its products. Nevertheless, semiconductor devices in general can malfunction or fail due to their inherent electrical sensitivity and vulnerability to physical stress. It is the responsibility of the buyer, when utilizing TOSHIBA products, to observe standards of safety, and to avoid situations in which a malfunction or failure of a TOSHIBA product could cause loss of human life, bodily injury or damage to property. In developing your designs, please ensure that TOSHIBA products are used within specified operating ranges as set forth in the most recent products specifications. Also, please keep in mind the precautions and conditions set forth in the TOSHIBA Semiconductor Reliability Handbook.
- Gallium arsenide (GaAs) is a substance used in the products described in this document. GaAs dust and fumes are toxic. Do not break, cut or pulverize the product, or use chemicals to dissolve them. When disposing of the products, follow the appropriate regulations. Do not dispose of the products with other industrial waste or with domestic garbage.
- The information contained herein is presented only as a guide for the applications of our products. No responsibility is assumed by TOSHIBA CORPORATION for any infringements of intellectual property or other rights of the third parties which may result from its use. No license is granted by implication or otherwise under any intellectual property or other rights of TOSHIBA CORPORATION or others.
- The information contained herein is subject to change without notice.

2. Recommended Operating Conditions

ITEM	SYMBOL	MIN.	TYP.	MAX.	UNIT
Supply Voltage	V _{CC}	4.75	5.0	5.25	V
High Level Input Voltage	V _{IH}	2.0	—	V _{CC}	V
Low Level Input Voltage	V _{IL}	0	—	0.8	V
High Level Output Current	I _{OH}	—	—	-60	μA
Low Level Output Current	I _{OL}	—	—	1.2	mA

3. Electrical and Optical Characteristics (Ta = 25°C, V_{CC} = 5V)

ITEM	SYMBOL	CONDITION	MIN.	TYP.	MAX.	UNIT
Data Rate		NRZ Code ⁽²⁾	DC	—	6	Mb/s
Transmission Distance		Using APF ⁽³⁾ , DC~6Mb/s	0.2	—	40	m
Pulse Width Distortion ⁽⁴⁾	Δtw	Using TODX270A Pulse width 165ns Pulse cycle 330ns, C _L =10pF	-55	—	55	ns
Fiber Output Power	P _f	R=0Ω ⁽⁵⁾	-15	—	-9	dBm
Peak Emission Wavelength	λ _p		—	650	—	nm
Maximum Receivable Power ⁽⁶⁾	P _{MAX}	DC~6Mb/s, Using APF	-15	—	—	dBm
Minimum Receivable Power ⁽⁶⁾	P _{MIN}	DC~6Mb/s, Using APF	—	—	-27	dBm
Current Consumption	I _{CC}	R=0Ω	—	85	115	mA
High Level Input Voltage	V _{IH}		2.0	—	—	V
Low Level Input Voltage	V _{IL}		—	—	0.8	V
High Level Input Current	I _{IH}		—	—	20	μA
Low Level Input Current	I _{IL}		—	—	-0.4	mA
High Level Output Voltage	V _{OH}		4.6	—	—	V
Low Level Output Voltage	V _{OL}		—	—	0.4	V

⁽²⁾ LED is on when input signal is high level, it is off when low level.

High level output when optical flux is received. Low level output when it is not received.

For data rate > 3Mb/s, the duty factor must be kept 25 to 75%.

⁽³⁾ All Plastic Fiber (980/1000μm).

⁽⁴⁾ Between input of TODX270A and output of TODX270A.

⁽⁵⁾ Measure with a standard optical fiber with fiber optic connectors. Valued by peak.

⁽⁶⁾ BER ≤ 10⁻⁹, Valued by peak.

4. Example of Typical Characteristics ⁽⁸⁾

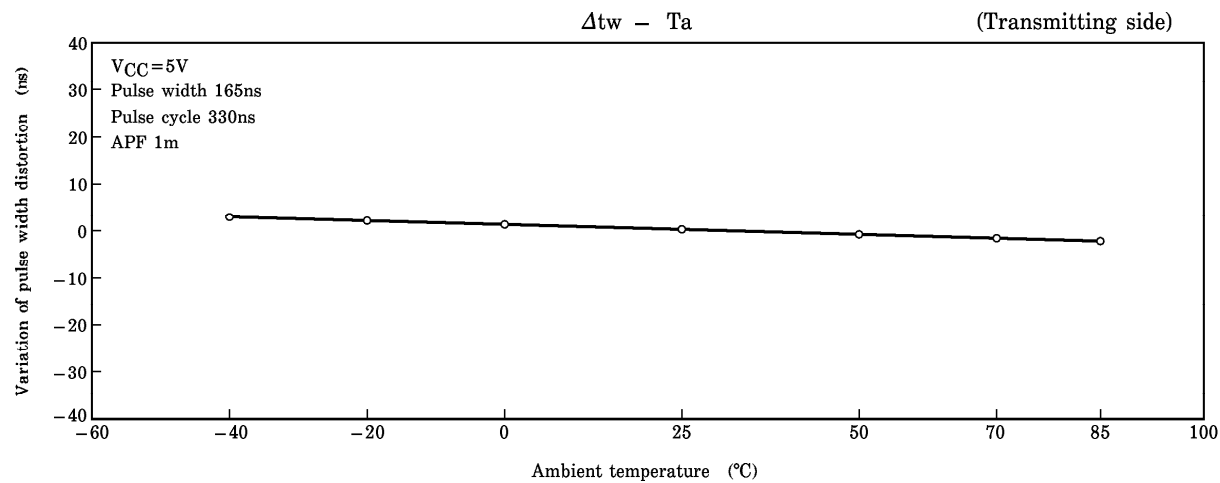
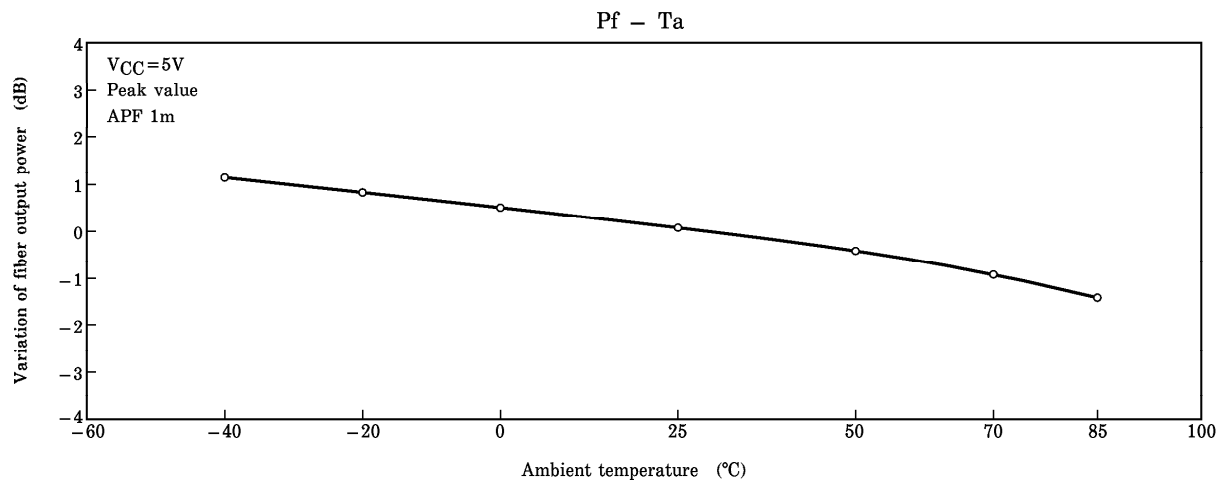
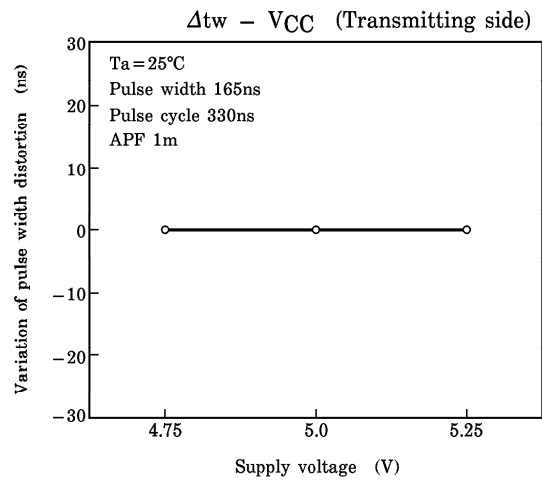
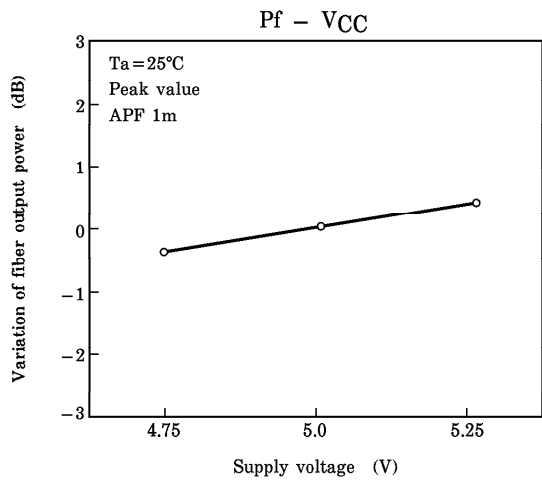

Note. ⁽⁸⁾ There give characteristic examples, and its values are not guaranteed.

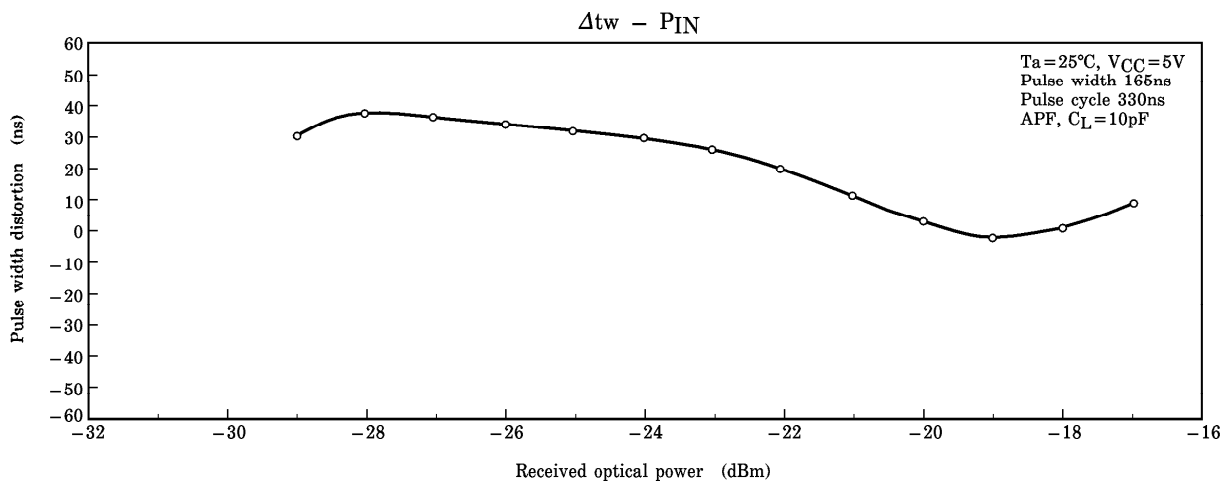
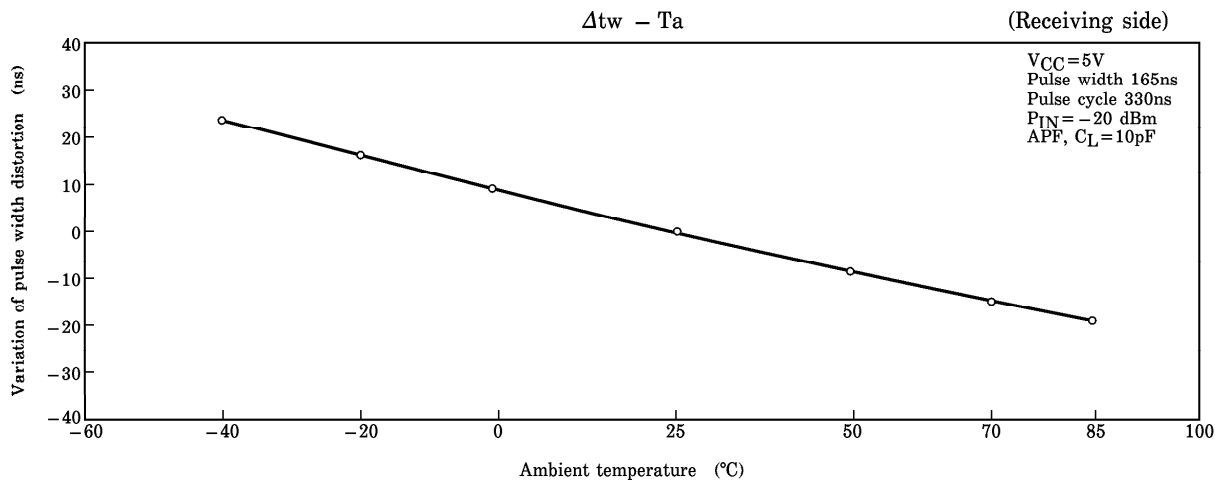
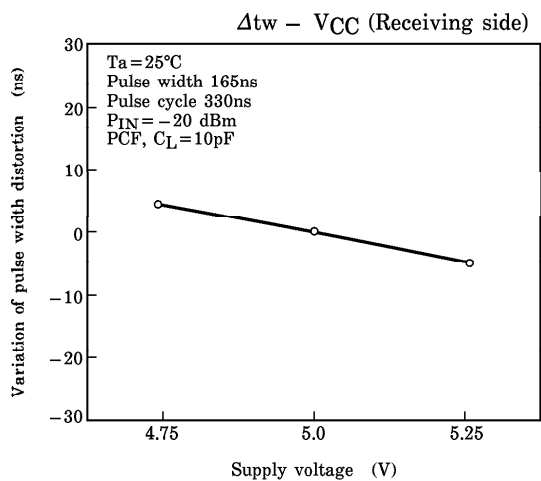

Note. ⁽⁹⁾ There give characteristic examples, and its values are not guaranteed.

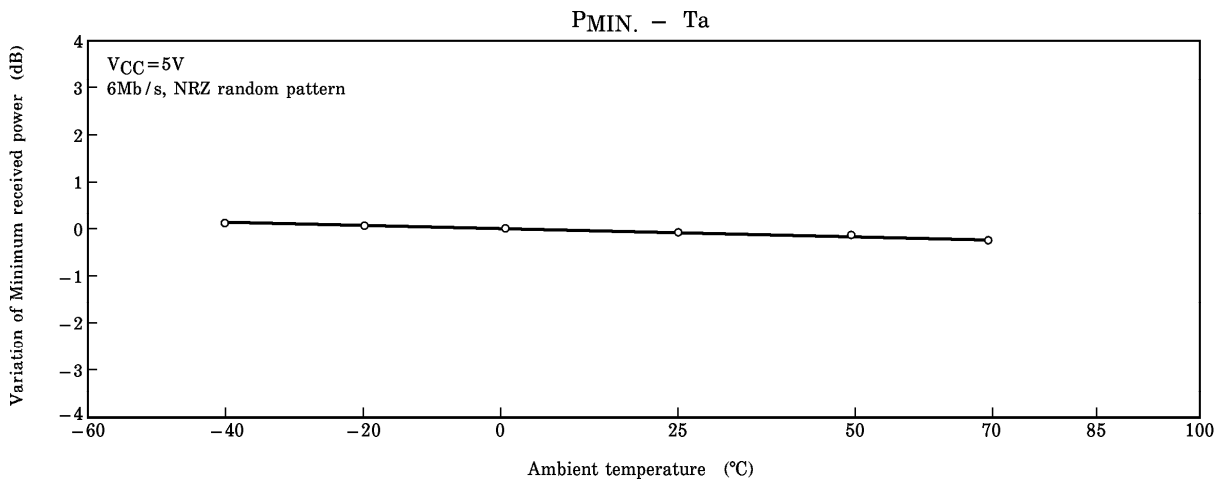
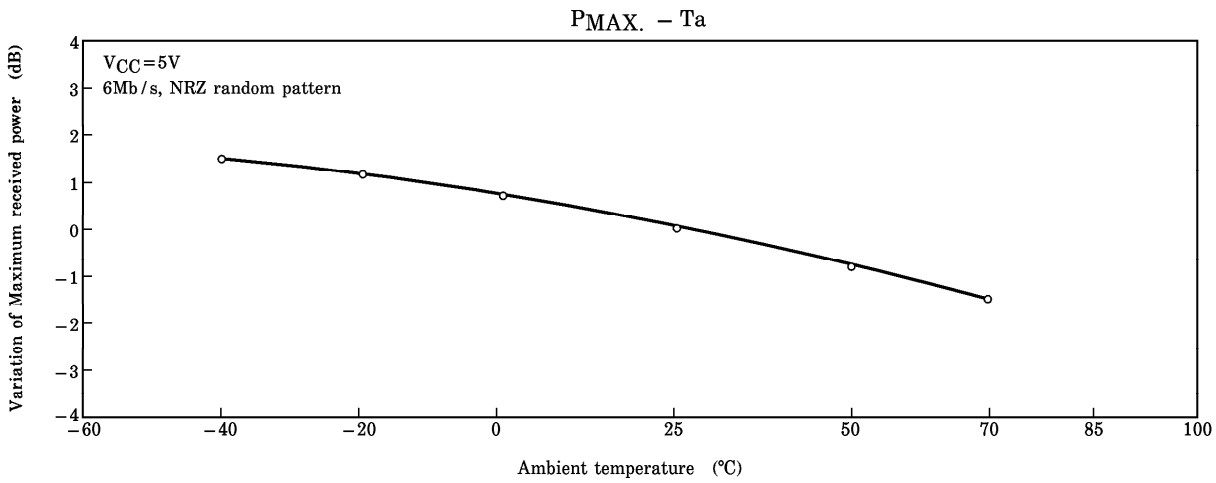
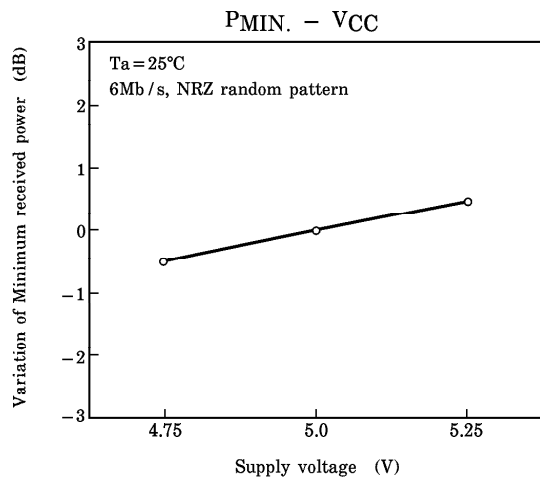
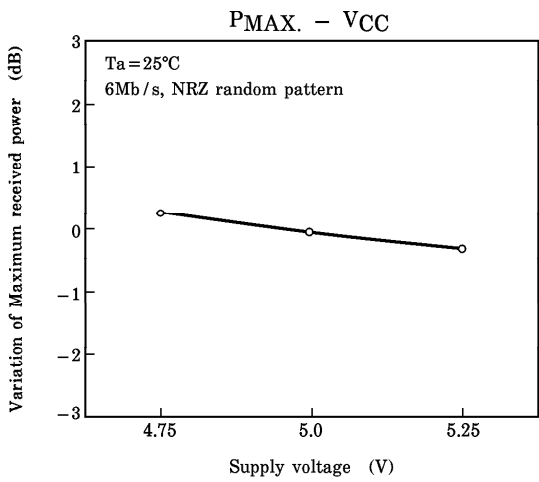

Note. ⁽⁸⁾ There give characteristic examples, and its values are not guaranteed.

5. Connection Method

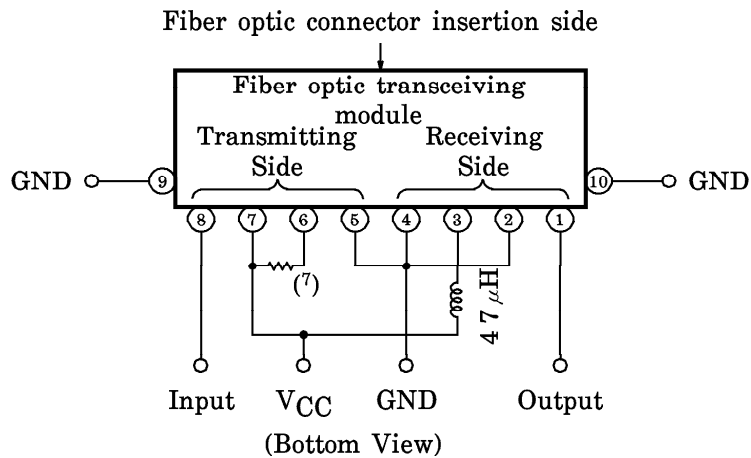

(7) Select a resistor value as follows :

TRANSMISSION DISTANCE (m)	RESISTOR (Ω)
0.2 to 15	8.2k
15 to 30	2.4k
30 to 40	0

6. Applicable Optical Fiber with Fiber Optic Connectors

TOCP200-□□B, TOCP255-□□B, TOCP200P-□□B, TOCP255P-□□B

7. Precaution on Use

(1) Maximum Rating

The maximum ratings are the limit values which must not be exceeded when using the device. Any one of the rating must not be exceeded. If The maximum rating is exceeded, the characteristics may not be recovered. In some extreme cases, the device may be permanently damage.

(2) Life of Light Emitters

When the optical module is used for over a long period, degeneration of characteristics is mostly due to lowering of the fiber output power (Pf). This is caused by the degradation of the optical output of the LED's used as the light source. The cause of degradation of the optical output of the LED's may be defects in wafer crystallization or mold resin stress. The detailed causes are, however, not clear.

The life of light emitters is greatly influenced by operating conditions and usage environment as well as the life characteristics unique to the device. Thus, when selecting a light emitter and setting the operating conditions, Toshiba recommends that you check the life characteristics.

Depending on the environment conditions, Toshiba recommends maintenance such as regular checks on the amount of optical output.

(3) Soldering

Optical modules use semiconductor devices internally. However, in principle, optical modules are optical components. At soldering, take care that flux dose not contact the emitting surface or detecting surface. Also take care at flux removal after soldering.

Some optical modules come with protective cap. The protective cap is used to avoid malfunction when the optical module is not in use. Not that it is not dust or waterproof. As mentioned before, optical modules are optical component. Thus, in principle, soldering where there may be flux residue or flux removal after soldering is not recommended. Toshiba recommends that soldering be performed without the optical module mounted on the board. Then, after the board is cleaned, solder the optical module manually. Do not perform any further cleaning.

If the optical module cannot be soldered manually, use non-halogen (chlorine-free) flux and make sure, without cleaning, there is no residue such as chlorine. This is one of the ways to eliminate the effects of flux. In such a case, check the reliability.

(4) Noise Resistance

Where the fiber optic transceiving module case uses conductive resin, shield by connecting the reinforcing pin at a front end of the module to GND. When using this optical module, connect the pin to SIGNAL-GND.

Where the fiber optic transceiving module case has a resistance of several tens of ohms, take care that the case does not contact power line of other circuits.

It is believed that the use of optical transfer devices improve the noise resistance. In principle, optical fiber is not affected by noise. However, especially receiving module which handle signals whose level is extremely small, are comparatively more susceptible to noise.

TOSLINK improves noise resistance using a conductive case. However, the current of the signal output from the photodiode of the optic transceiving module is extremely small. Thus, depending on the usage environment, shielding the case is not sufficient for noise resistance. When using TOSLINK, Toshiba recommends that you test using the actual device and check the noise resistance.

Use a simple noise filter on the TOSLINK fiber optic transceiving module power line. If the ripple in power supply used is high, further reinforce the filter.

When locating the optical module in an area susceptible to radiated noise, increase shielding by covering the optical module and the power line filter using a metallic cover.

(5) Vibration and Shock

This module is resin-molded construction with wire fixed by resin. This structure is relatively sound against vibration or shock, In actual equipment, there are some cases where vibration, shock, and stress is applied to soldered parts or connected parts, resulting in line cut. Attention must be paid to the design of the mechanism for applications which are subject to large amounts of vibration.

(6) Fixing Fiber Optical Transceiving Module

Solder the fixed pin (pins 9 and 10) of fiber optic transceiving module TODX270A to the printed circuit board to fix the module to the board.

(7) Shielding and Wiring Pattern of Fiber Optic Transceiving Modules

To shield, connect the fixed pins (pins 9 and 10) of fiber optic transceiving module TODX270A to the GND.

Where the fiber optic transceiving module uses conductive resin, be careful that the case does not touch wiring (including land).

To improve noise resistance, shield the optical module and the power line filter using a metallic cover.

(8) Solvent

When using solvent for flux removal, do not use a high acid or high alkali solvent. Be careful not to pour solvent in the optical connector ports. If solvent is inadvertently poured there, clean with cotton tips.

(9) Protective Cap

When the fiber optic transceiving module TODX270A is not in use, use the protective cap.

(10) Supply Voltage

Use the supply voltage within the Typ. operating condition ($V_{CC} = 5 \pm 0.25V$). Make sure that supply voltage does not exceed the maximum rating value of 7V, even instantaneously.

(11) Input Voltage

If a voltage exceeding the maximum rating value ($V_{CC} + 0.5V$) is applied to the transmitter input, the internal IC may degrade causing some damage. If excessive voltage due to surges may be added to the input, insert a protective circuit.

(12) Output

When the receiver output is at low level and connected to the power supply, or when the output is at high level and connected to GND, the internal IC may be destroyed.

(13) Soldering Condition

Solder at 260°C or less within three seconds.

(14) Precaution on Waste

When discarding devices and packing materials, follow procedures stipulated by local regulations in order to protect the environment against contamination.

Compound semiconductors such as GaAs are used as LED materials for this module. When discarding waste or at final processing, attention must be paid to workers and the environment.

(15) Precaution on Use

Toshiba is continually working to improve the quality and the reliability of its products. Nevertheless, semiconductor devices in general can malfunction or fail due to their inherent electrical sensitivity and vulnerability to physical stress. It is the responsibility of the buyer, when utilizing Toshiba products, to observe standards of safety, and to avoid situations in which a malfunction or failure of a Toshiba product could cause loss of human life, bodily injury or damage to property.

In developing your designs, please ensure that Toshiba products are used within specified operating ranges as set forth in the most recent product specifications. Also, please keep in mind the precautions and conditions set forth in the Toshiba Semiconductor Reliability Handbook.