

# AN3328S

## 2-head recording and playback amplifier IC (A2) for HiFi VCR

### Overview

The AN3328S is a 2-head recording and playback amplifier IC for HiFi audio, and realized reduction of pin numbers. The package is a small outline of 16 pins, 1.27 mm pitch and supply voltage is 5 V of single supply.

### Features

- Damping-less amp. in playback system
- No adjustment of recording current by AGC
- 3-step switchover of recording current level with the current emphasis switch (typ.  $\pm 1.8$  dB)

### Applications

- HiFi VCR

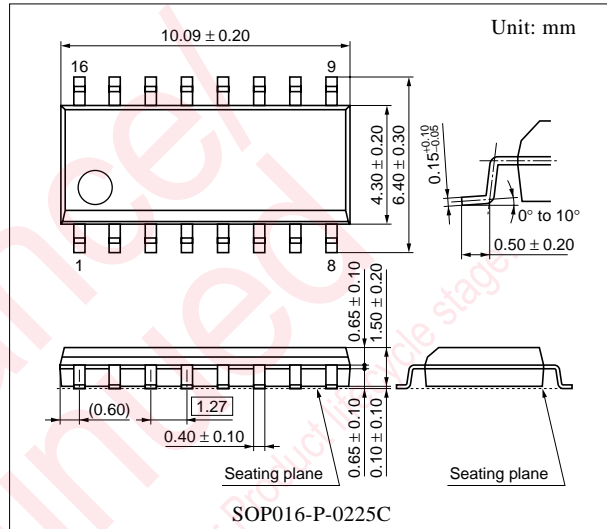

### Block Diagram

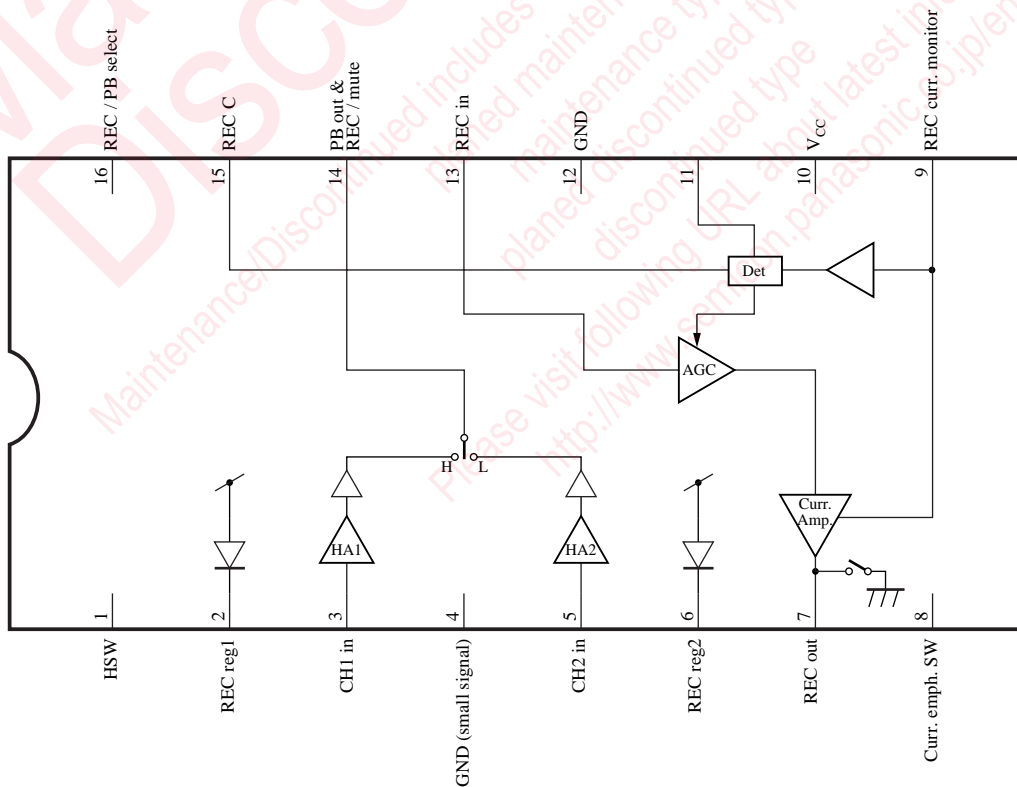

### ■ Pin Descriptions

Pin No.	Description	Pin No.	Description
1	Audio head SW	9	REC curr. monitor (control)
2	REC regulator1	10	V <sub>CC</sub>
3	Head amp. input ch.1	11	REC AGC det
4	GND (small signal)	12	GND
5	Head amp. input ch.2	13	REC input
6	REC regulator2	14	PB out & REC / mute SW
7	REC out	15	REC C
8	Curr. emph. SW	16	REC/PB select SW

### ■ Absolute Maximum Ratings

Parameter	Symbol	Rating	Unit
Supply voltage	V <sub>CC</sub>	6	V
Supply current	I <sub>CC</sub>	—	mA
Power dissipation*2	P <sub>D</sub>	240	mW
Operating ambient temperature*1	T <sub>opr</sub>	-20 to +70	°C
Storage temperature*1	T <sub>stg</sub>	-55 to +125	°C

Note) \*1: Except for the operating ambient temperature and storage temperature, all ratings are for T<sub>a</sub> = 25°C.

\*2: The power dissipation shown is for the IC package in free air at T<sub>a</sub> = 70°C.

### ■ Recommended Operating Range

Parameter	Symbol	Range	Unit
Supply voltage	V <sub>CC</sub>	4.5 to 5.5	V

■ Electrical Characteristics at  $T_a = 25^\circ\text{C}$

Parameter	Symbol	Conditions	Min	Typ	Max	Unit
REC Circuit current	$I_{10(\text{REC})}$	$V_{CC} = 5.0 \text{ V}$ REC / PB SW: High	56	(66)	76	mA
REC AGC level	$I_7$	$V_{CC} = 5.0 \text{ V}$ REC / PB SW: High	44	(48)	52	mA[p-p]
REC AGC control characteristics	$DI_7$	$V_{CC} = 5.0 \text{ V}$ REC / PB SW: High	—	(0.2)	1.0	dB
REC Recording current 2nd harmonic distortion	$D_7$	$V_{CC} = 5.0 \text{ V}$ , REC / PB SW: High $V_{IN} = 260 \text{ mV[p-p]}$ , 2 MHz	—	(-43)	-35	dB
REC Mode hold voltage	$V_{16H}$	$V_{CC} = 5.0 \text{ V}$ , REC / Mute SW: Low $V_{IN} = 260 \text{ mV[p-p]}$ , 2 MHz	3.6	—	$V_{CC}$	V
REC Over REC hold voltage	$V_{8L}$	$V_{CC} = 5.0 \text{ V}$ REC / PB SW: High	0	—	1.2	V
REC Normal hold voltage	$V_{8M}$	$V_{CC} = 5.0 \text{ V}$ REC / PB SW: High	1.8	—	3.2	V
REC S-VHS hold voltage	$V_{8H}$	$V_{CC} = 5.0 \text{ V}$ REC / PB SW: High	3.8	—	$V_{CC}$	V
REC Over REC current ratio	$I_{7L} \rightarrow I_7$	$V_{CC} = 5.0 \text{ V}$ REC / PB SW: High	1.3	(1.8)	2.3	dB
REC S-VHS current ratio	$I_{7H} \rightarrow I_7$	$V_{CC} = 5.0 \text{ V}$ REC / PB SW: High	-2.3	(-1.8)	-1.3	dB
REC Mute hold voltage 1	$V_{14H(\text{REC})}$	$V_{CC} = 5.0 \text{ V}$ REC / PB SW: High	3.6	—	$V_{CC}$	V
REC Mute hold voltage 2	$V_{14L(\text{REC})}$	$V_{CC} = 5.0 \text{ V}$ REC / PB SW: High	0	—	1.4	V
PB Circuit current	$I_{10(\text{PB})}$	$V_{CC} = 5.0 \text{ V}$ REC / PB SW: Low	9	(13)	17	mA
PB CH1 gain	$G_{3-14}$	$V_{CC} = 5.0 \text{ V}$ , REC / PB SW: Low HSW: High, $V_{IN} = 0.1 \text{ mV[p-p]}$ , 2 MHz	72	(76)	80	dB
PB CH2 gain	$G_{5-14}$	$V_{CC} = 5.0 \text{ V}$ , REC / PB SW: Low HSW: Low, $V_{IN} = 0.1 \text{ mV[p-p]}$ , 2 MHz	72	(76)	80	dB
PB CH1 1.5 M / 2 M gain ratio	$DG_{3-14}$	$V_{CC} = 5.0 \text{ V}$ , REC / PB SW: Low HSW: High, $V_{IN} = 0.1 \text{ mV[p-p]}$ , 2 MHz	0	(0.5)	1	dB
PB CH2 1.5 M / 2 M gain ratio	$DG_{5-14}$	$V_{CC} = 5.0 \text{ V}$ , REC / PB SW: Low HSW: Low, $V_{IN} = 0.1 \text{ mV[p-p]}$ , 2 MHz	0	(0.5)	1	dB
PB CH1 / CH2 gain ratio	$G_{3-14} \rightarrow G_{5-14}$	$V_{CC} = 5.0 \text{ V}$ , REC / PB SW: Low $V_{IN} = 0.1 \text{ mV[p-p]}$ , 2 MHz	-2	0	2	dB
Noise referred to PB CH1 input	$N_{3-14}$	$V_{CC} = 5.0 \text{ V}$ REC / PB SW: Low HSW: High	—	—	1.0	mV[rms]
Noise referred to PB CH2 input	$N_{5-14}$	$V_{CC} = 5.0 \text{ V}$ REC / PB SW: Low HSW: Low	—	—	1.0	mV[rms]

Note) The typical value in the parenthesis is not the guaranteed one.

■ Electrical Characteristics at  $T_a = 25^\circ\text{C}$  (continued)

Parameter	Symbol	Conditions	Min	Typ	Max	Unit
PB Mode hold voltage	$V_{16L}$	$V_{CC} = 5.0\text{ V}$ REC / PB SW: Low	0	—	1.4	V
PB CH1 hold voltage	$V_{1H(PB)}$	$V_{CC} = 5.0\text{ V}$ REC / PB SW: Low	3.6	—	$V_{CC}$	V
PB CH2 hold voltage	$V_{1L(PB)}$	$V_{CC} = 5.0\text{ V}$ REC / PB SW: Low	0	—	1.4	V
PB HSW DC unbalanced	$DV_{\text{OFFSET}}$	$V_{CC} = 5.0\text{ V}$ REC / PB SW: Low	—	—	20	mV[p-p]

• Design reference data

Note) The characteristics listed below are theoretical values based on the IC design and are not guaranteed.

Parameter	Symbol	Conditions	Min	Typ	Max	Unit
REC Cross modulation distortion at 0.4 MHz	$CMD_{0.4M}$	$V_{CC} = 5.0\text{ V}$ REC / PB SW: High	—	(-45)	—	dB
REC Cross modulation distortion at 0.9 MHz	$CMD_{0.9M}$	$V_{CC} = 5.0\text{ V}$ REC / PB SW: High	—	(-52)	—	dB
REC Muting ratio	$I_M / I_7$	$V_{CC} = 5.0\text{ V}$ REC / PB SW: High	—	—	-40	dB
PB Crosstalk CH1 to CH2	$CT_1$	$V_{CC} = 5.0\text{ V}$ REC / PB SW: Low	—	-40	—	dB
PB Crosstalk CH2 to CH1	$CT_2$	$V_{CC} = 5.0\text{ V}$ REC / PB SW: Low	—	-40	—	dB
PB CH1, Output 2nd harmonic distortion	$D_{3-14}$	$V_{CC} = 5.0\text{ V}$ , HSW: High REC / PB SW: Low	—	-50	—	dB
PB CH2, Output 2nd harmonic distortion	$D_{5-14}$	$V_{CC} = 5.0\text{ V}$ , HSW: Low REC / PB SW: Low	—	-50	—	dB

Note) The typical value in the parenthesis is not the guaranteed one.

■ Terminal Equivalent Circuits

Pin No.	Equivalent Circuit	Description	Voltage	Remark
1		Audio head SW	Input signal 	At open : High (ch.1 Select)
2		REC regulator 1	D.C	—
3		Head amp. input ch.1	0.7 V	—
4	—	GND (small signal)	—	—
5		Head amp. input ch.2	0.7 V	—

■ Terminal Equivalent Circuits (continued)

Pin No.	Equivalent Circuit	Description	Voltage	Remark
6		REC regulator	2	D.C
7		REC out	A.C	—
9		REC curr. monitor (control)		
8		Curr. emph. SW	Input signal	At open: Middle (Curr. emph. normal mode)
10	—	V <sub>CC</sub>	—	—
11		REC AGC det	D.C	—
12	—	GND	—	—



■ Application Circuit Example

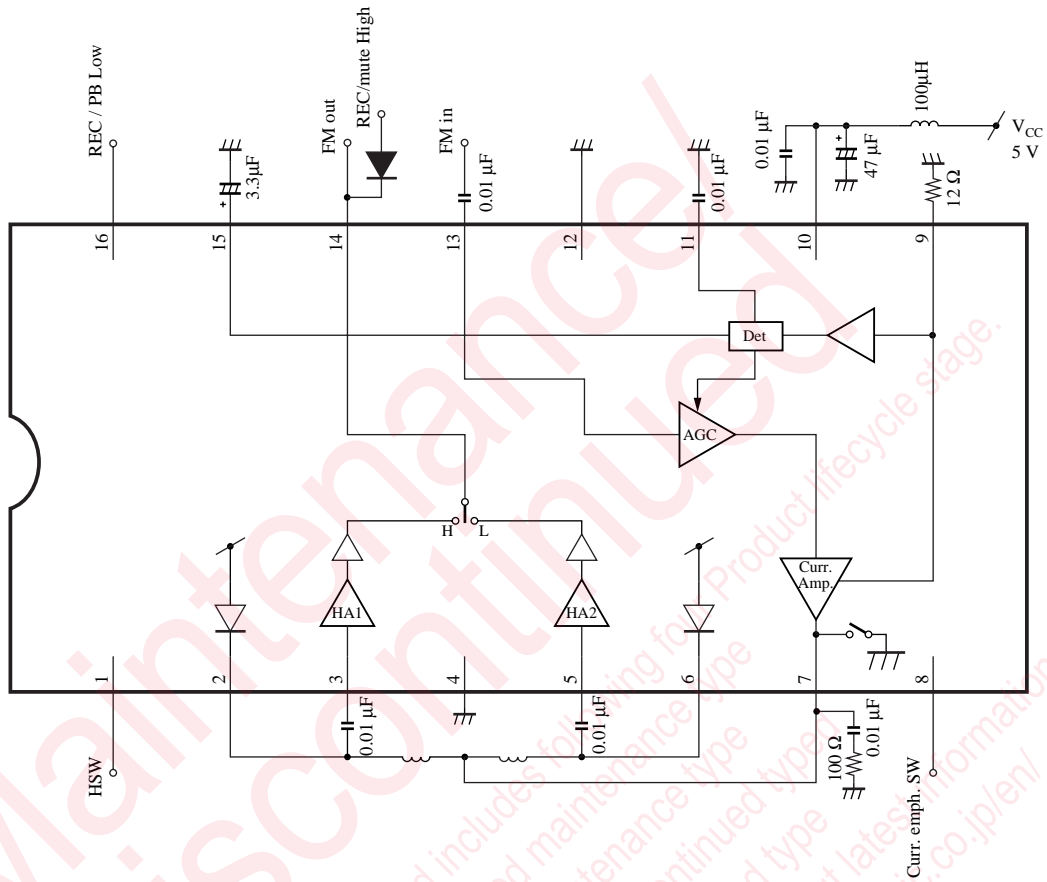

## Request for your special attention and precautions in using the technical information and semiconductors described in this book

- (1) If any of the products or technical information described in this book is to be exported or provided to non-residents, the laws and regulations of the exporting country, especially, those with regard to security export control, must be observed.
- (2) The technical information described in this book is intended only to show the main characteristics and application circuit examples of the products, and no license is granted under any intellectual property right or other right owned by our company or any other company. Therefore, no responsibility is assumed by our company as to the infringement upon any such right owned by any other company which may arise as a result of the use of technical information described in this book.
- (3) The products described in this book are intended to be used for standard applications or general electronic equipment (such as office equipment, communications equipment, measuring instruments and household appliances).  
Consult our sales staff in advance for information on the following applications:
  - Special applications (such as for airplanes, aerospace, automobiles, traffic control equipment, combustion equipment, life support systems and safety devices) in which exceptional quality and reliability are required, or if the failure or malfunction of the products may directly jeopardize life or harm the human body.
  - Any applications other than the standard applications intended.
- (4) The products and product specifications described in this book are subject to change without notice for modification and/or improvement. At the final stage of your design, purchasing, or use of the products, therefore, ask for the most up-to-date Product Standards in advance to make sure that the latest specifications satisfy your requirements.
- (5) When designing your equipment, comply with the range of absolute maximum rating and the guaranteed operating conditions (operating power supply voltage and operating environment etc.). Especially, please be careful not to exceed the range of absolute maximum rating on the transient state, such as power-on, power-off and mode-switching. Otherwise, we will not be liable for any defect which may arise later in your equipment.
  - Even when the products are used within the guaranteed values, take into the consideration of incidence of break down and failure mode, possible to occur to semiconductor products. Measures on the systems such as redundant design, arresting the spread of fire or preventing glitch are recommended in order to prevent physical injury, fire, social damages, for example, by using the products.
- (6) Comply with the instructions for use in order to prevent breakdown and characteristics change due to external factors (ESD, EOS, thermal stress and mechanical stress) at the time of handling, mounting or at customer's process. When using products for which damp-proof packing is required, satisfy the conditions, such as shelf life and the elapsed time since first opening the packages.
- (7) This book may be not reprinted or reproduced whether wholly or partially, without the prior written permission of Matsushita Electric Industrial Co., Ltd.