

BU-63152

MIL-STD-1553 DATA BUS DUAL TRANSCEIVER

Make sure the next
Card you purchase
has...

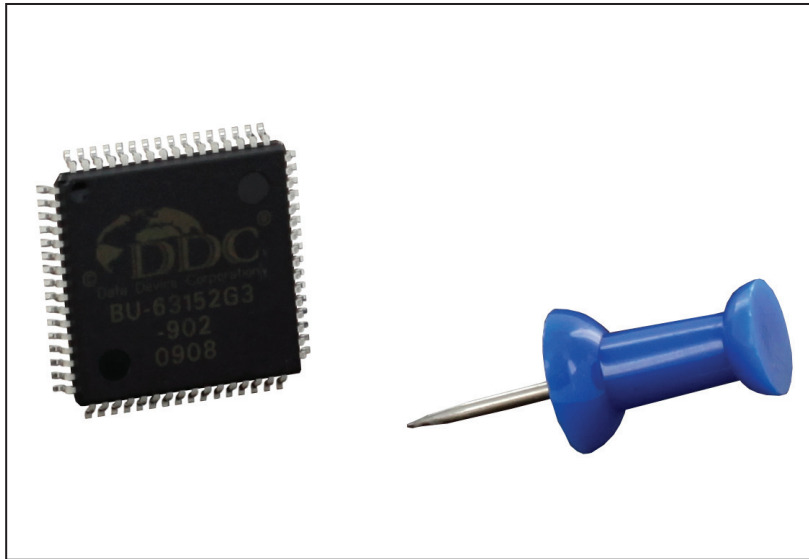

FEATURES

- Requires only +5V Power Supply
- Small Size - 64 Pin QFP
- Low Power
- Dual Transceiver
- HARRIS I/O Compatibility
- Conforms fully to MIL-STD-1553A, -1553B, and -1760

DESCRIPTION

The BU-63152 transceiver is a complete dual transmitter and receiver pair conforming fully to MIL-STD-1553A, 1553B, and 1760. Features include: +5V power supply voltage, Harris interface type, completely independent dual redundant operation, and small size 64-pin Quad Flat Package (QFP).

The receiver section of the BU-63152 series accepts phase-modulated bipolar data from a MIL-STD-1553 Data Bus and produces TTL level signals at its outputs: RX DATA OUT and RX DATA OUT. These outputs represent positive and negative variations of the input data signals beyond an internally fixed threshold level. An external STROBE input enables or disables the receiver's outputs.

The transmitter section accepts bipolar TTL signal data at its TX DATA IN and TX DATA IN inputs and produces phase-modulated bipolar data at the TX DATA OUT and TX DATA OUT outputs. When used with the recommended transformers, the transmitter typically produces 21Vp-p for transformer coupled outputs and 7.2Vp-p at the bus. An external input, INHIBIT, takes priority over the transmitter inputs and disables the transmitter when activated with a logic "1".

The small size, +5V power supply voltage, and compliance with MIL-STD-1553A, 1553B, and 1760 simplify engineering design, making it an excellent choice for interfacing with any MIL-STD-1553 system.

FOR MORE INFORMATION CONTACT:

Technical Support:
1-800-DDC-5757 ext. 7771



Data Device Corporation
105 Wilbur Place
Bohemia, New York 11716
631-567-5600 Fax: 631-567-7358
www.ddc-web.com

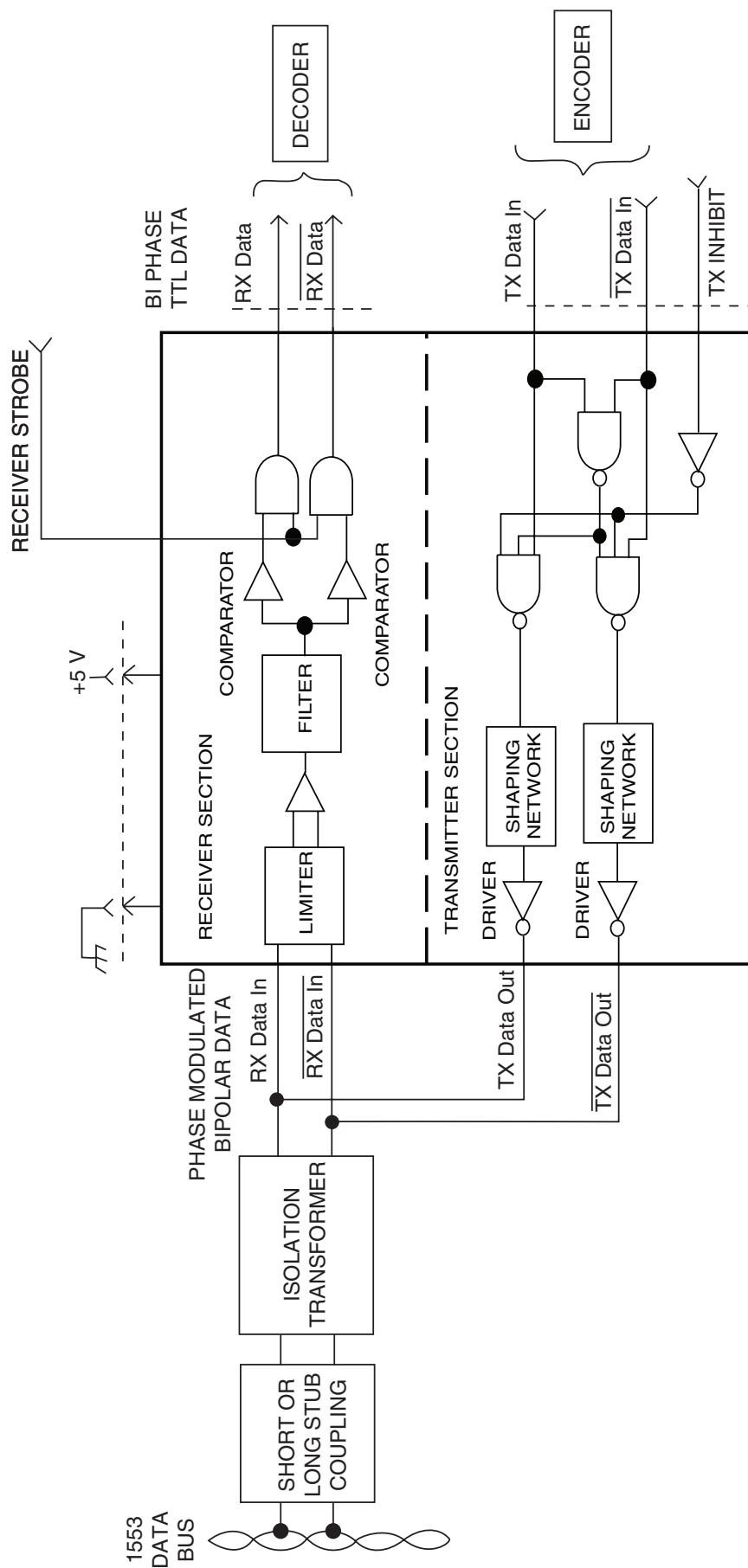

FIGURE 1. BU-63152 BLOCK DIAGRAM

TABLE 1. BU-63152 SPECIFICATIONS

PARAMETER	MIN	TYP	MAX	UNITS
ABSOLUTE MAXIMUM RATING				
Supply Voltage • +5 V (Vcc)	-0.3	5.0	7.0	V
Receiver • Input Voltage (to transformer)			20	Vp-p
Logic • Voltage Input Range	-0.3		Vcc+0.3	V
MIL-STD-1553 Signals • Powered Input Range (Note 12)	-5V_XCVR - 0.3		5V_XCVR + 0.3	V
• Unpowered Input Range	-1.5		+1.5	V
RECEIVER				
Differential Input Resistance (Notes 1-6)	2.5			kohm
Differential Input Capacitance (Notes 1-6)			5	pF
Threshold Level (Note 7)	0.20		0.860	Vp-p
Common Mode Voltage (Note 8)			10	Vpeak
TRANSMITTER				
Differential Output Voltage • Direct Coupled Across 35 Ω, Measured on Bus	6	7.4	9	Vp-p
• Transformer Coupled Across 70 Ω, Measured on Stub (Note 9)	20	22	27	Vp-p
Output Noise, Differential (Direct Coupled)			10	mVp-p, diff
Dynamic Output Offset Voltage, Transformer Coupled Across 70Ω	-250	0	+250	mVp-p, diff
Rise/Fall Time	100	150	300	ns
LOGIC				
V _{IH}	2.0		Vcc	V
V _{IL}	0		0.8	V
I _{IH} (TXIN, TXIN, TXINHIBIT)	20		100	μA
I _{IH} (STROBE)			0	μA
I _{IL} (TXIN, TXIN, TXINHIBIT)	0			μA
I _{IL} (STROBE)	-100		-20	μA
V _{OH} (Vcc=4.75V, I _{OH} =max)	4.0			V
V _{OL} (Vcc=4.75V, I _{OL} =min)			0.4	V
I _{OL}	4.0			mA
I _{OH}			-2.4	mA
POWER SUPPLY REQUIREMENTS				
Voltages/Tolerances • +5V	4.75	5.0	5.25	V
Current Drain (Both Channels)				
• Idle		80	100	mA
• 25% Transmitter Duty Cycle (One Channel Transmitting)		210	240	mA
• 50% Transmitter Duty Cycle (One Channel Transmitting)		308	370	mA
• 100% Transmitter Duty Cycle (One Channel Transmitting)		500	580	mA
POWER DISSIPATION, Vcc=5.0V				
One Channel (Note 10)				
• Idle		0.20	0.25	W
• 25% Transmitter Duty Cycle		0.48	0.65	W
• 50% Transmitter Duty Cycle		0.70	0.95	W
• 100% Transmitter Duty Cycle		1.00	1.35	W
THERMAL				
• Operating Ambient Temperature	-55		85	°C
• Thermal Resistance, Junction-to-Ambient (θ _{JA})(Either Channel) (Note 11)		40	45	°C/W
• Operating Junction Temperature	-55		150	°C
• Storage Temperature	-65		150	°C
• Lead Temperature (soldering, 10 sec.)			+300	°C
PHYSICAL CHARACTERISTICS				
Moisture Sensitivity Level	MSL-3			
Package	64-Pin QFP			
Size	14.00 x 14.00 x 2.00 (0.551 x 0.551 x 0.079)			mm (in)
Weight	0.5 (14)			oz (g)

Refer to Table 1 notes on next page.

TABLE 1 NOTES

(Notes 1 through 6 are applicable to the Receiver Differential Resistance and Differential Capacitance specifications:)

- (1) Specifications include both transmitter and receiver (assumed tied together externally).
- (2) Impedance parameters are specified directly between pins TX/RX A(B) and TX/RX A(B) of the hybrid.
- (3) It is assumed that all power and ground inputs to the hybrid are connected.
- (4) The specifications are applicable for both unpowered and powered conditions.
- (5) The specifications assume a 2 volt rms balanced, differential, sinusoidal input. The applicable frequency range is 75 kHz to 1 MHz.
- (6) Minimum resistance and maximum capacitance parameters are guaranteed over the operating range, but are not tested.
- (7) The Threshold Level, as referred to in this specification, is meant to be the maximum peak-to-peak voltage (measured on the stub) that can be applied to the receiver's input without causing the output to change from the OFF state.
- (8) Assumes a common mode voltage within the frequency range of dc to 2 MHz, applied to pins of the isolation transformer on the stub side (either direct or transformer coupled), and referenced to transceiver ground. Transformer must be a DDC recommended transformer or other transformer that provides an equivalent minimum CMRR.
- (9) MIL-STD-1760 requires minimum output voltage of 20 Vp-p on the stub connection.
- (10) Power dissipation specifications assume a transformer coupled configuration, with external dissipation (while transmitting) of 0.14 watts for the active isolation transformer, 0.08 watts for the active coupling transformer, 0.45 watts for each of the two bus isolation resistors, and 0.15 watts for each of the two bus termination resistors.
- (11) Thermal resistance, Junction-to-Ambient (θ_{JA}) (Either Channel) applies when the device is soldered to a 4 in x 4 in x 0.060 in (FR4 or equivalent) PC board with a "1-oz" (1.4 mil thickness) ground-plane layer on the back of the board, positioned horizontally in still air.
- (12) Assuming the use of isolation transformers with the turns ratios shown in Figure 3 and in the absence of common mode signal on the 1553 stub, this equates to a nominal stub voltage of 38 Volts_{PK-to-PK} transformer-coupled, or 53 Volts_{PK-to-PK} direct-coupled.

GENERAL

The BU-63152 is a dual redundant transmitter and receiver packaged in a 64-pin QFP (see Figure 5). It is directly compatible to Harris 15530 encoder/decoder and has internal (factory preset) threshold levels. Requiring only a +5V power supply, the BU-63152 is designed for use in any MIL-STD-1553 application.

FIGURE 1 shows a BU-63152 transceiver connected to a MIL-STD 1553 Data Bus. Once transformer isolated, coupling to a MIL-STD-1553 Data Bus can be either short stub (direct) or long stub (transformer). The recommended transformer for long and short stub coupling is Beta P/N B-3226 (through hole) or B-3227 (surface mount). There are other transformer configurations available from Beta. Reference FIGURE 3 and TABLE 2.

TRANSMIT OPERATING MODE

The transmitter section accepts encoded TTL data and converts it to phase-modulated differential format by means of a wave-shaping network and driver circuitry. These driver outputs are coupled to a MIL-STD-1553 Data Bus via a transformer which is driven from the TX DATA OUT and $\overline{\text{TX DATA OUT}}$ terminals. These output terminals can be put into a high impedance state when transmitting by bringing the respective TX_INHIBIT input to logic "1", or by placing both inputs at the same logic level. TABLE 3, Transmit Operating Mode, lists the functions for the output data and input data in reference to the state of INHIBIT.

The transceivers are able to operate in a "wraparound" mode. This allows output data to be monitored by the receiver section and returned to the decoder where it can be checked for errors.

RECEIVER OPERATING MODE

The receiver section accepts data from a MIL-STD-1553 Data Bus when properly coupled in either of the two possible configu-

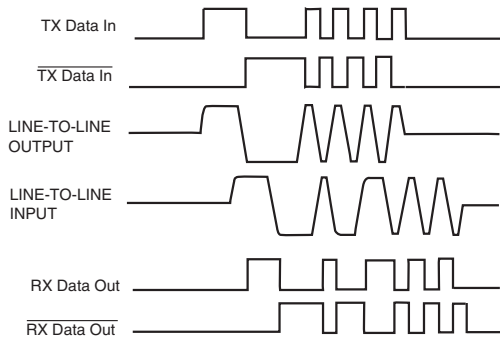

Notes:

- (1) TX Data In and RX Data Out are TTL signals.
- (2) TX Data In inputs must be at opposite logic levels during transmission, and at a low logic level when not transmitting.
- (3) LINE-TO-LINE output voltage is measured between TX Data Out and $\overline{\text{TX DATA OUT}}$.
- (4) LINE-TO-LINE input voltage is measured on the Data Bus.

FIGURE 2. TYPICAL OPERATING WAVEFORMS

rations (long or short stub). This data is converted to bi-phase TTL and made available for decoding at the RX DATA and $\overline{\text{RX DATA}}$ terminals. Applying a logic "1" to the STROBE input allows data to pass through to the receiver output. Applying a logic "0" to the STROBE input turns the receiver output OFF.

The BU-63152 receiver outputs are both at a logic "0" when they are either strobed off, or no signal is being received. This is directly compatible with a "Harris" type of encoder/decoder. Compatibility to a "Smiths" type of encoder/decoder may be accomplished by swapping the RX DATA OUT and $\overline{\text{RX DATA OUT}}$ outputs and then inverting them (see FIGURE 4).

BU-63152 WAVEFORMS

FIGURE 2 illustrates the waveforms for the BU-63152. Note that DATA and $\overline{\text{DATA}}$ inputs must be complementary waveforms of 50% average duty cycle while transmitting.

TRANSFORMERS

In selecting isolation transformers to be used with the BU-63152, there is a limitation on the maximum amount of leakage inductance. If this limit is exceeded, the transmitter rise and fall times may increase, possibly causing the bus amplitude to fall below the minimum level required by MIL-STD-1553. In addition, an excessive leakage imbalance may result in a transformer dynamic offset that exceeds 1553 specifications.

The maximum allowable leakage inductance is 6.0 μH , and is measured as follows:

The side of the transformer that connects to the BU-63152 is defined as the "primary" winding. If one side of the primary is shorted to the primary center-tap, the inductance should be measured across the "secondary" (stub side) winding. This inductance must be less than 6.0 μH . Similarly, if the other side of the primary is shorted to the primary center-tap, the inductance measured across the "secondary" (stub side) winding must also be less than 6.0 μH .

The difference between these two measurements is the "differential" leakage inductance. This value must be less than 1.0 μH .

Beta Transformer Technology Corporation (BTTC), a subsidiary of DDC, manufactures transformers in a variety of mechanical configurations with the required turns ratios of 1:2.5 direct coupled, and 1:1.79 transformer coupled. TABLE 2 provides a listing of many of these transformers.

For further information, contact BTTC at 631-244-7393 or at www.btcc-beta.com.

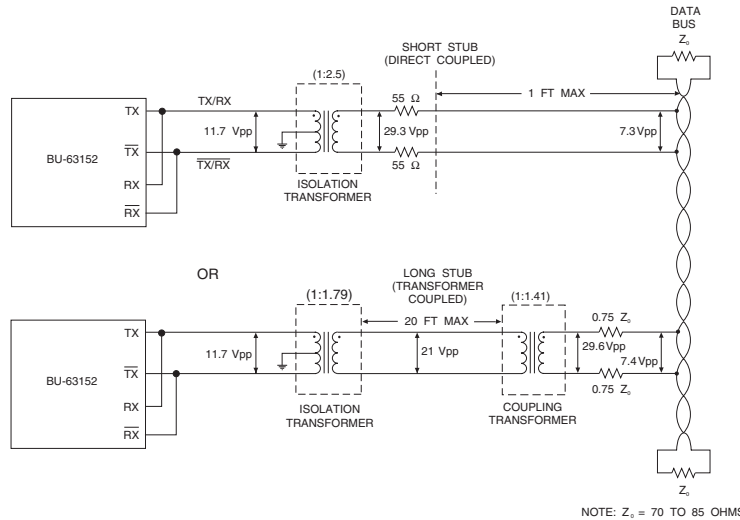

FIGURE 3. BUS COUPLING CONFIGURATIONS (TYPICAL PEAK-TO-PEAK VOLTAGES INDICATED)

TABLE 2. BTTC TRANSFORMERS FOR USE WITH BU-63152

BTTC PART NUMBER	# OF CHANNELS, CONFIGURATION	COUPLING RATIO DESCRIPTION	COUPLING RATIO (1:X)	MOUNTING	MAX HEIGHT	WIDTH (INCLUDING LEADS)	LENGTH (INCLUDING LEADS)
MLP-2005	Single	Direct	(1:2.5)	SMT	0.185"	0.4"	0.52"
MLP-3005	Single	Direct	(1:2.5)	Through Hole	0.185"	0.4"	0.4"
B-3230 (-30) #	Single	Direct	(1:2.5)	Through Hole	0.25"	0.35"	0.5"
MLP-2205	Single	Transformer	(1:1.79)	SMT	0.185"	0.4"	0.52"
MLP-3205	Single	Transformer	(1:1.79)	Through Hole	0.185"	0.4"	0.4"
B-3229 (-29) #	Single	Transformer	(1:1.79)	Through Hole	0.25"	0.35"	0.5"
HLP-6015 #	Single	Direct & Transformer	(1:2.5) & (1:1.79)	SMT	0.19"	0.63"	1.13"
B-3227 (-27) #	Single	Direct & Transformer	(1:2.5) & (1:1.79)	SMT	0.29"	0.63"	1.13"
MLP-3305	Single	Direct & Transformer	(1:2.5) & (1:1.79)	Through Hole	0.185"	0.4"	0.4"
B-3226 (-26) #	Single	Direct & Transformer	(1:2.5) & (1:1.79)	Through Hole	0.25"	0.625"	0.625"
HLP-6014 #	Single	Direct & Transformer	(1:2.5) & (1:1.79)	Flat Pack	0.19"	0.63"	1.13"
B-3231 (-31) #	Single	Direct & Transformer	(1:2.5) & (1:1.79)	Flat Pack	0.29"	0.63"	1.13"
DSS-2005	Dual (Side-by-Side)	Direct	(1:2.5)	SMT	0.13"	0.72"	0.96"
DSS-2205	Dual (Side-by-Side)	Transformer	(1:1.79)	SMT	0.13"	0.72"	0.96"
DSS-1005	Dual (Side-by-Side)	Direct & Transformer	(1:2.5) & (1:1.79)	SMT	0.165"	0.72"	0.96"
TSM-2005	Dual (Stacked)	Direct	(1:2.5)	SMT	0.32"	0.4"	0.52"
TSM-2205	Dual (Stacked)	Transformer	(1:1.79)	SMT	0.32"	0.4"	0.52"
TST-9117 #	Dual (Stacked)	Direct & Transformer	(1:2.5) & (1:1.79)	SMT	0.335"	1.125"	1.125"
TST-9107 #	Dual (Stacked)	Direct & Transformer	(1:2.5) & (1:1.79)	Through Hole	0.335"	0.625"	0.625"
TST-9127 #	Dual (Stacked)	Direct & Transformer	(1:2.5) & (1:1.79)	Flat Pack	0.335"	0.625"	0.625"

Notes:

1. All Transformers in the table above can be used with BU-6XXXXX3/6 (1553B transceivers).
2. Transformers identified with "#" in the table above are not recommended for use with the BU-6XXXXX4 (McAir-Comptable transceivers)

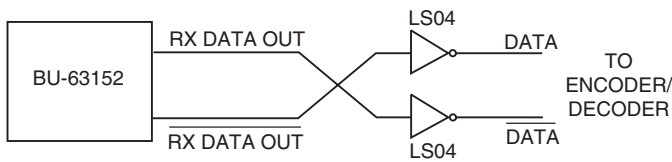
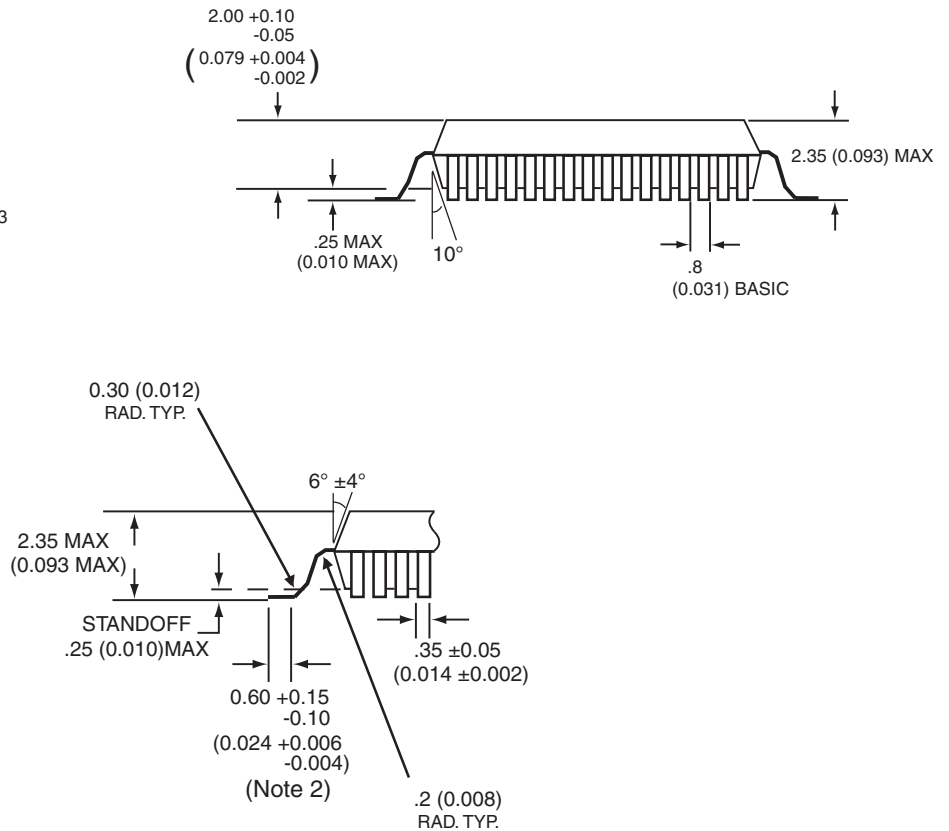
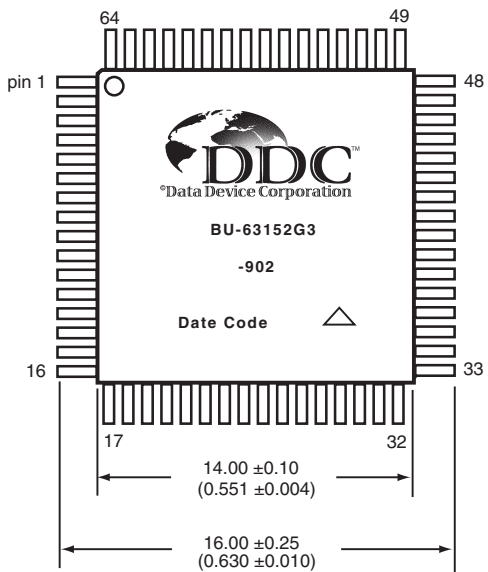

FIGURE 4. SMITHS ENCODER/DECODER COMPATIBILITY

TABLE 3. TRANSMIT OPERATING MODE			
TX Data In	$\overline{\text{TX Data In}}$	TX INHIBIT	DRIVER OUTPUT ⁽²⁾
X	X	H	OFF ⁽³⁾
0	0	X	OFF
0	1	L	ON ⁽⁴⁾
1	0	L	ON ⁽⁴⁾
1	1	X	OFF

Notes:

- (1) X = Don't Care
- (2) DRIVER OUT = TX Data Out and $\overline{\text{TX Data Out}}$
- (3) DRIVER OUTPUT terminals are in the high impedance mode during OFF time, independent of INHIBIT status.
- (4) TX Data In and $\overline{\text{TX Data In}}$ must be switching (as shown in FIGURE 2) and must not be set in a "static" I/O or O/I condition.



Notes:

- (1) Dimensions shown are in millimeters (inches)
- (2) Foot length is measured at gage plane, 6.4 (0.25) above seating plane.

FIGURE 5. BU-63152 QFP OUTLINE DRAWING

TABLE 4. BU-63152 PIN FUNCTIONS

PIN	FUNCTION	CHANNEL
1	GND	A
2	TX Data Out	A
3	TX Data Out	A
4	+5V	A
5	+5V	A
6	$\overline{\text{TX Data Out}}$	A
7	$\overline{\text{TX Data Out}}$	A
8	GND	B
9	Factory Test Input *	B
10	Factory Test Input *	B
11	GND	B
12	+5V	B
13	+5V	B
14	RX Data Out	B
15	Strobe	B
16	$\overline{\text{RX Data Out}}$	B
17	Factory Test Input *	B
18	GND	B
19	+5V	B
20	+5V	B
21	+5V	B
22	GND	B
23	GND	B
24	GND	B
25	RX Data In	B
26	$\overline{\text{RX Data In}}$	B
27	Factory Test Output *	B
28	+5V	B
29	+5V	B
30	TX Inhibit	B
31	TX Data In	B
32	$\overline{\text{TX Data In}}$	B

TABLE 4. BU-63152 PIN FUNCTIONS (CONT.)

PIN	FUNCTION	CHANNEL
33	GND	B
34	TX Data Out	B
35	TX Data Out	B
36	+5V	B
37	+5V	B
38	$\overline{\text{TX Data Out}}$	B
39	$\overline{\text{TX Data Out}}$	B
40	GND	A
41	Factory Test Input *	A
42	Factory Test Input *	A
43	GND	A
44	+5V	A
45	+5V	A
46	RX Data Out	A
47	Strobe	A
48	$\overline{\text{RX Data Out}}$	A
49	Factory Test Input *	A
50	GND	A
51	+5V	A
52	+5V	A
53	+5V	A
54	GND	A
55	GND	A
56	GND	A
57	RX Data In	A
58	$\overline{\text{RX Data In}}$	A
59	Factory Test Output *	A
60	+5V	A
61	+5V	A
62	TX Inhibit	A
63	TX Data In	A
64	$\overline{\text{TX Data In}}$	A

* No User Connections; factory test points.

ORDERING INFORMATION

BU-63152G3-902

Test Criteria:

2 = MIL-STD-1760 Amplitude Compliant

Process Requirements:

0 = Standard DDC Processing, no Burn-In

Temperature Grade/Data Requirements:

9 = -55 to +85°C, Ambient

Rise/Fall Times Option:

3 = +5 Volts, rise/fall times = 100 to 300 ns (-1553B)

Package Type:

G = Quad Gull Lead Package (QFP)

Base Product Type:

BU-63152 = Dual +5V Plastic QFP Transceiver

Note: 1) The above products contain tin-lead solder finish as applicable to solder dip requirements.

PLASTIC MONOLITHIC PROCESSING TABLE

STANDARD DDC PROCESSING FOR PLASTIC MONOLITHIC PRODUCTS		
TEST	MIL-STD-883	
	METHOD(S)	CONDITION(S)
INSPECTION / WORKMANSHIP	2017	—
ELECTRICAL TEST	DDC ATP	—

The information in this data sheet is believed to be accurate; however, no responsibility is assumed by Data Device Corporation for its use, and no license or rights are granted by implication or otherwise in connection therewith.
Specifications are subject to change without notice.



®Data Device Corporation

105 Wilbur Place, Bohemia, New York, U.S.A. 11716-2426

For Technical Support - 1-800-DDC-5757 ext. 7771

Headquarters, N.Y., U.S.A. - Tel: (631) 567-5600, Fax: (631) 567-7358

United Kingdom - Tel: +44-(0)1635-811140, Fax: +44-(0)1635-32264

France - Tel: +33-(0)1-41-16-3424, Fax: +33-(0)1-41-16-3425

Germany - Tel: +49-(0)89-15 00 12-11, Fax: +49-(0)89-15 00 12-22

Japan - Tel: +81-(0)3-3814-7688, Fax: +81-(0)3-3814-7689

Asia -Tel: +65-6489-4801

World Wide Web - <http://www.ddc-web.com>



DATA DEVICE CORPORATION
REGISTERED TO:
ISO 9001:2008, AS9100C:2009-01
EN9100:2009, JIS Q9100:2009
FILE NO. 10001296 ASH09