



DIONICS, INC.

65 Rushmore Street
Westbury, NY 11590

Phone: (516) 997-7474

Fax: (516) 997-7479

Website: www.dionics-usa.com

GAS DISCHARGE DISPLAY SEGMENT DRIVERS

DI-232

DI-242

General Description:

The DIONICS DI-232 and DI-242 circuits are designed to drive gas discharge display devices from signals originating from MOS or TTL circuitry. Each output is a switched programmable constant current sink with a voltage compliance of 80 Volts or 125 Volts.

These circuits provide for simple interface with display such as Beckman, SP-452, Cherry W410-1051 or Dale PD-16A040.

Features:

- ✓ High Breakdown Voltage: 80V or 125V.
- ✓ High Input Voltage Capability: 40V
- ✓ TTL or MOS Compatible
- ✓ Each Output Programmed By a Single Resistor
- ✓ Requires Few Additional Components
- ✓ Dielectrically Isolated Integrated Circuits
- ✓ DC Restoring Input Diode

Package Layout:

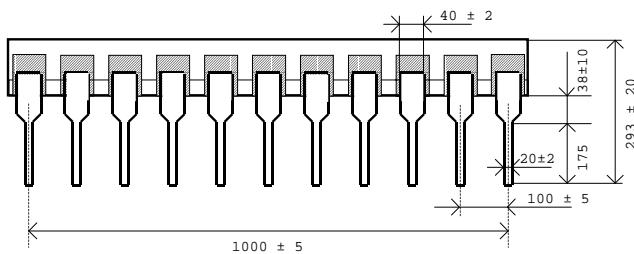
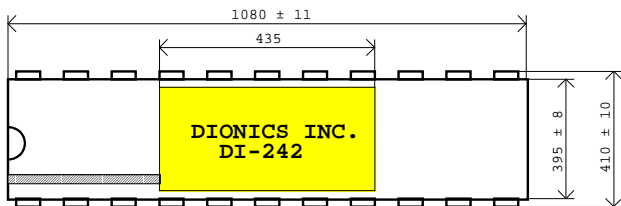

Pin Connections

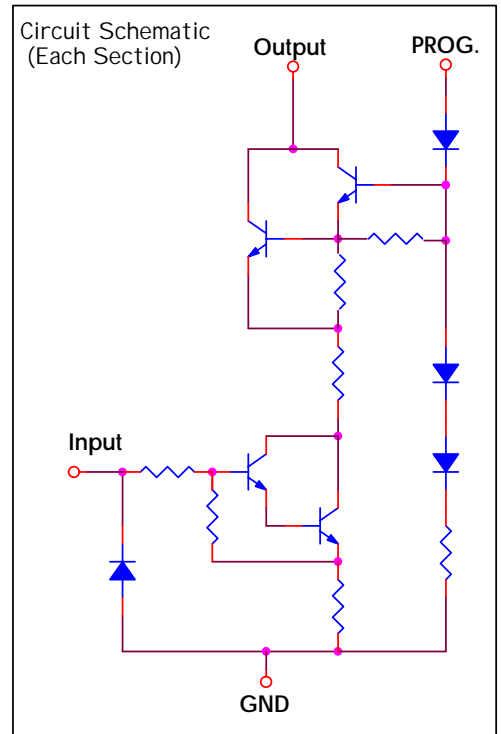
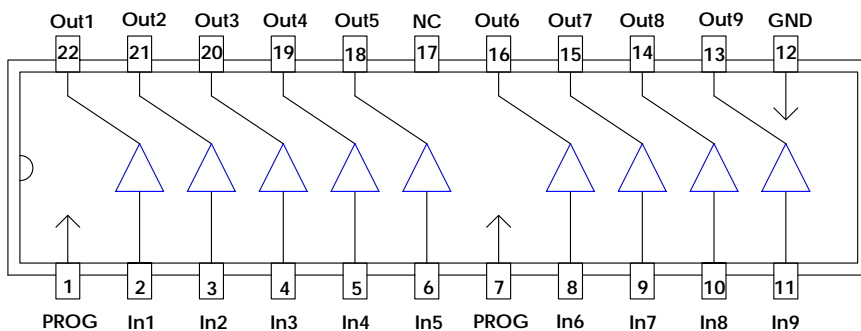

Absolute Maximum Rating ($T_a = 25^\circ\text{C}$)

Characteristic	Symbol	Notes	Limits	Units
Input Voltage	V_{in}	Measured With Respect to GND Terminal	40	V
Output Current	I_o		5	mA
Output Voltage DI-232	V_o	Measured With Respect to GND Terminal	80	V
Output Voltage DI-242	V_o	Measured With Respect to GND Terminal	125	V
Power Dissipation DI-232; DI-242	P_D	Derate at 8 mW/ $^\circ\text{C}$ Above 25°C Ambient	1100	mW
Storage Temperature	T_s		-55 to +125	$^\circ\text{C}$
Operating Temperature	T_o		0 to +70	$^\circ\text{C}$

Electrical Characteristics ($T_a = 25^\circ\text{C}$)

Parameter	Symbol	Conditions	Min.	Typ.	Max.	Units
Output Saturation Voltage	V_o (SAT)	$I_o=1\text{mA}$; $V_i=3.5\text{V}$; $R_p=27\text{k}\Omega$; $V_p=10\text{V}$		5		V
Output Leakage Current	I_o (OFF)	$V_o = \text{Rated Voltage}$; $V_i = 0.4\text{V}$; $R_p = 27\text{k}\Omega$; $V_p = 10\text{V}$		0.1	10	μA
Output Current Match	$\Delta I_o / I_o$	$V_o=60\text{V}$; $V_i=3.5\text{V}$; $R_p=27\text{k}\Omega$; $V_p=10\text{V}$		± 5	± 10	%
Output Current	I_o (ON)	$V_o=60\text{V}$; $V_i=3.5\text{V}$; $R_p=27\text{k}\Omega$; $V_p=10\text{V}$	1.0	1.2	1.4	mA
Input Current	I_i	$V_i = 7.0\text{V}$	250	370	500	μA

Typical Application:

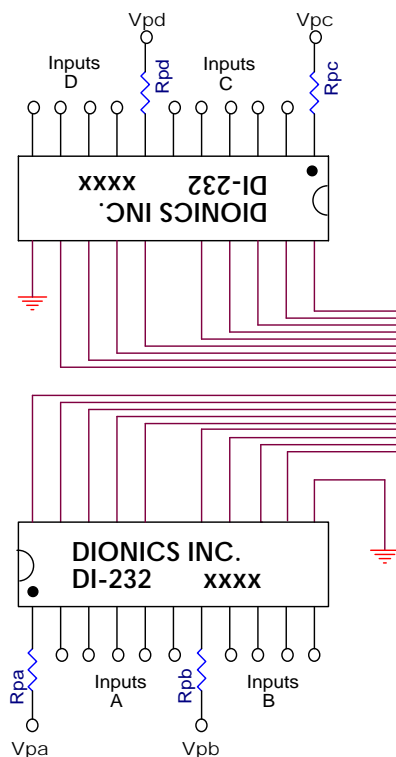

V_p : PROGRAM VOLTAGE
 R_p : PROGRAM RESISTOR

ALPHA NUMERIC DISPLAY

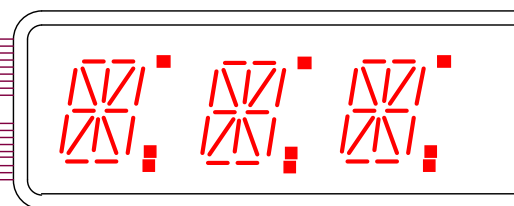

TWO DI-232 PROVIDE 4 GROUPS OF OUTPUTS EACH HAVING DIFFERENT AND INDEPENDENT PROGRAMMED SEGMENT CURRENT LEVELS

