

HIGH PERFORMANCE

3.3 VOLT 1M x 8 EDO PAGE MODE

CMOS DYNAMIC RAM

HIGH PERFORMANCE	35	40	45	50
Max. $\overline{\text{RAS}}$ Access Time, (t_{RAC})	35 ns	40 ns	45 ns	50 ns
Max. Column Address Access Time, (t_{CAA})	18 ns	20 ns	22 ns	24 ns
Min. Extended Data Out Mode Cycle Time, (t_{PC})	14 ns	15 ns	17 ns	19 ns
Min. Read/Write Cycle Time, (t_{RC})	70 ns	75 ns	80 ns	90 ns

Features

- 1M x 8-bit organization
- EDO Page Mode for a sustained data rate of 67 MHz
- $\overline{\text{RAS}}$ access time: 35, 40, 45, 50 ns
- Low power dissipation
- Read-Modify-Write, $\overline{\text{RAS}}$ -Only Refresh, $\overline{\text{CAS}}$ -Before- $\overline{\text{RAS}}$ Refresh capability
- Refresh Interval: 1024 cycles/16 ms
- Available in 28-pin 400 mil SOJ and 28-pin TSOP-II packages
- Single +3.3V \pm 0.3V Power Supply
- TTL Interface

Description

The V53C808L is a ultra high speed 1,048,576 x 8 bit CMOS dynamic random access memory. The V53C808H offers a combination of features: Page Mode with Extended Data Output for high data bandwidth, and Low CMOS standby current.

All inputs and outputs are TTL compatible. Input and output capacitances are significantly lowered to allow increased system performance. Page Mode with Extended Data Output operation allows random access of up to 1024 (x8) bits within a row with cycle times as fast as 14 ns. The V53C808L is ideally suited for graphics, digital signal processing and high-performance computing systems.

Device Usage Chart

Operating Temperature Range	Package Outline		Access Time (ns)				Power	Temperature Mark
	K	T	35	40	45	50	Std.	
0°C to 70 °C	•	•	•	•	•	•	•	Blank

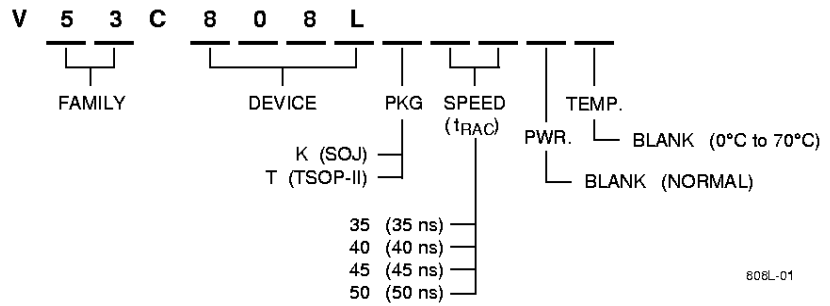

Description	Pkg.	Pin Count
SOJ	K	28
TSOP-II	T	28

808L-01

**28-Pin Plastic SOJ
PIN CONFIGURATION
Top View**

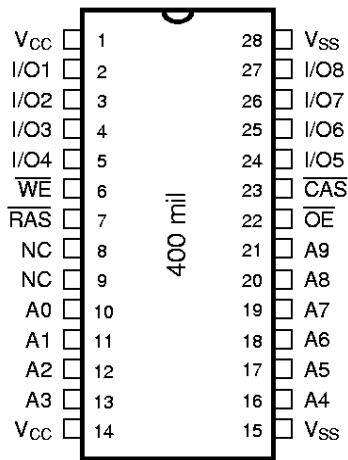

808H-02

**28-Pin Plastic TSOP-II
PIN CONFIGURATION
Top View**

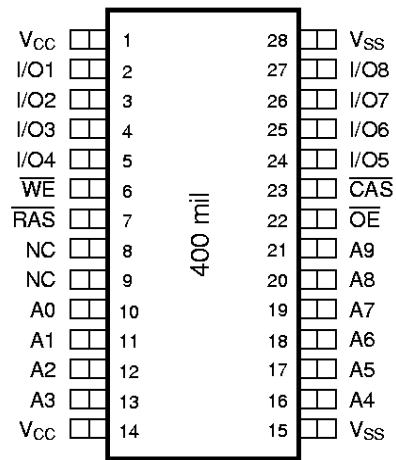

808H-03

Pin Names

A ₀ -A ₉	Address Inputs
RAS	Row Address Strobe
CAS	Column Address Strobe
WE	Write Enable
OE	Output Enable
I/O ₁ -I/O ₈	Data Input, Output
V _{CC}	+5V Supply
V _{SS}	0V Supply
NC	No Connect

Absolute Maximum Ratings*

Ambient Temperature
 Under Bias -10°C to +80°C
 Storage Temperature (plastic) -55°C to +125°C
 Voltage Relative to V_{SS} -1.0 V to +4.6 V
 Data Output Current 50 mA
 Power Dissipation 1.0 W

*Note: Operation above Absolute Maximum Ratings can adversely affect device reliability.

Capacitance*

T_A = 25°C, V_{CC} = 3.3V ± 0.3V, V_{SS} = 0 V

Symbol	Parameter	Typ.	Max.	Unit
C _{IN1}	Address Input	3	4	pF
C _{IN2}	$\overline{\text{RAS}}$, $\overline{\text{CAS}}$, $\overline{\text{WE}}$, $\overline{\text{OE}}$	4	5	pF
C _{OUT}	Data Input/Output	5	7	pF

* Note: Capacitance is sampled and not 100% tested

Block Diagram

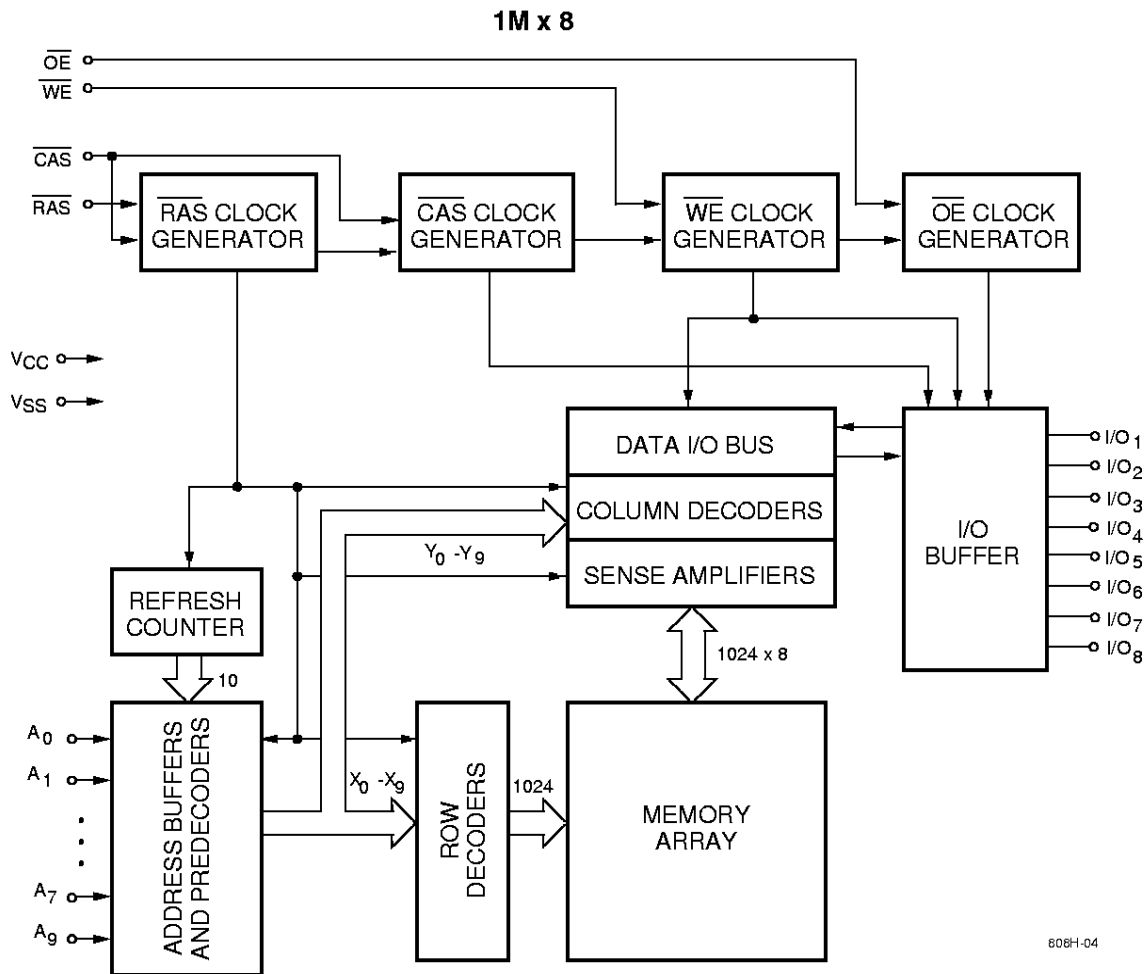

808H-04

DC and Operating Characteristics

$T_A = 0^\circ\text{C}$ to 70°C , $V_{CC} = 3.3\text{V} \pm 0.3\text{V}$, $V_{SS} = 0\text{V}$, unless otherwise specified.

Symbol	Parameter	Access Time	V53C808L			Unit	Test Conditions	Notes
			Min.	Typ.	Max.			
I_{LI}	Input Leakage Current (any input pin)		-10		10	μA	$V_{SS} \leq V_{IN} \leq V_{CC}$	
I_{LO}	Output Leakage Current (for High-Z State)		-10		10	μA	$V_{SS} \leq V_{OUT} \leq V_{CC}$ $\overline{\text{RAS}}, \overline{\text{CAS}}$ at V_{IH}	
I_{CC1}	V_{CC} Supply Current, Operating	35			160	mA	$t_{RC} = t_{RC}(\text{min.})$	1, 2
		40			150			
		45			145			
		50			135			
I_{CC2}	V_{CC} Supply Current, TTL Standby				2	mA	$\overline{\text{RAS}}, \overline{\text{CAS}}$ at V_{IH} other inputs $\geq V_{SS}$	
I_{CC3}	V_{CC} Supply Current, RAS-Only Refresh	35			160	mA	$t_{RC} = t_{RC}(\text{min.})$	2
		40			150			
		45			145			
		50			135			
I_{CC4}	V_{CC} Supply Current, EDO Page Mode Operation	35			95	mA	Minimum cycle	1, 2
		40			90			
		45			85			
		50			80			
I_{CC5}	V_{CC} Supply Current, Standby, Output Enabled				2.0	mA	$\overline{\text{RAS}} = V_{IH}, \overline{\text{CAS}} = V_{IL}$ other inputs $\geq V_{SS}$	1
I_{CC6}	V_{CC} Supply Current, CMOS Standby				2.0	mA	$\overline{\text{RAS}} \geq V_{CC} - 0.2\text{V}$, $\overline{\text{CAS}} \geq V_{CC} - 0.2\text{V}$, All other inputs $\geq V_{SS}$	
V_{CC}	Supply Voltage		4.5	5.0	5.5	V		
V_{IL}	Input Low Voltage		-1		0.8	V		3
V_{IH}	Input High Voltage		2.4		$V_{CC} + 1$	V		3
V_{OL}	Output Low Voltage				0.4	V	$I_{OL} = 2\text{mA}$	
V_{OH}	Output High Voltage		2.4			V	$I_{OH} = -2\text{mA}$	

AC Characteristics

$T_A = 0^\circ\text{C}$ to 70°C , $V_{CC} = 3.3\text{V} \pm 0.3\text{V}$, $V_{SS} = 0\text{V}$ unless otherwise noted
 AC Test conditions, input pulse levels 0 to 3V

#	Symbol	Parameter	35		40		45		50		Unit	Notes
			Min.	Max.	Min.	Max.	Min.	Max.	Min.	Max.		
1	t_{RAS}	\overline{RAS} Pulse Width	35	75K	40	75K	45	75K	50	75K	ns	
2	t_{RC}	Read or Write Cycle Time	70		75		80		90		ns	
3	t_{RP}	\overline{RAS} Precharge Time	25		25		25		30		ns	
4	t_{CSH}	\overline{CAS} Hold Time	35		40		45		50		ns	
5	t_{CAS}	\overline{CAS} Pulse Width	7		8		9		9		ns	
6	t_{RCD}	\overline{RAS} to \overline{CAS} Delay	16	23	17	28	18	32	19	36	ns	
7	t_{RCS}	Read Command Setup Time	0		0		0		0		ns	4
8	t_{ASR}	Row Address Setup Time	0		0		0		0		ns	
9	t_{RAH}	Row Address Hold Time	6		7		8		9		ns	
10	t_{ASC}	Column Address Setup Time	0		0		0		0		ns	
11	t_{CAH}	Column Address Hold Time	4		5		6		7		ns	
12	$t_{RSH(R)}$	\overline{RAS} Hold Time (Read Cycle)	14		14		15		15		ns	
13	t_{CRP}	\overline{CAS} to \overline{RAS} Precharge Time	5		5		5		5		ns	
14	t_{RCH}	Read Command Hold Time Referenced to \overline{CAS}	0		0		0		0		ns	5
15	t_{RRH}	Read Command Hold Time Referenced to \overline{RAS}	0		0		0		0		ns	5
16	t_{ROH}	\overline{RAS} Hold Time Referenced to \overline{OE}	8		8		9		10		ns	
17	t_{OAC}	Access Time from \overline{OE}		12		12		13		14	ns	
18	t_{CAC}	Access Time from \overline{CAS} (EDO)		12		12		13		14	ns	6, 7
19	t_{RAC}	Access Time from \overline{RAS}		35		40		45		50	ns	6, 8, 9
20	t_{CAA}	Access Time from Column Address		18		20		22		24	ns	6, 7, 10
21	t_{LZ}	\overline{CAS} to Low-Z Output	0		0		0		0		ns	16
22	t_{HZ}	Output buffer turn-off delay time	0	6	0	6	0	7	0	8	ns	16
23	t_{AR}	Column Address Hold Time from \overline{RAS}	28		30		35		40		ns	
24	t_{RAD}	\overline{RAS} to Column Address Delay Time	11	17	12	20	13	23	14	26	ns	11
25	$t_{RSH(W)}$	\overline{RAS} or \overline{CAS} Hold Time in Write Cycle	12		12		13		14		ns	
26	t_{CWL}	Write Command to \overline{CAS} Lead Time	12		12		13		14		ns	
27	t_{WCS}	Write Command Setup Time	0		0		0		0		ns	12, 13
28	t_{WCH}	Write Command Hold Time	5		5		6		7		ns	
29	t_{WP}	Write Pulse Width	5		5		6		7		ns	

AC Characteristics (Cont'd)

#	Symbol	Parameter	35		40		45		50		Unit	Notes
			Min.	Max.	Min.	Max.	Min.	Max.	Min.	Max.		
30	t_{WCR}	Write Command Hold Time from \overline{RAS}	28		30		35		40		ns	
31	t_{RWL}	Write Command to \overline{RAS} Lead Time	12		12		13		14		ns	
32	t_{DS}	Data in Setup Time	0		0		0		0		ns	14
33	t_{DH}	Data in Hold Time	4		5		6		7		ns	14
34	t_{WOH}	Write to \overline{OE} Hold Time	5		6		7		8		ns	14
35	t_{OED}	\overline{OE} to Data Delay Time	5		6		7		8		ns	14
36	t_{RWC}	Read-Modify-Write Cycle Time	105		110		115		130		ns	
37	t_{RRW}	Read-Modify-Write Cycle \overline{RAS} Pulse Width	70		75		80		87		ns	
38	t_{CWD}	\overline{CAS} to \overline{WE} Delay	28		30		32		34		ns	12
39	t_{RWD}	\overline{RAS} to \overline{WE} Delay in	54		58		62		68		ns	12
40	t_{CRW}	\overline{CAS} Pulse Width (RMW)	46		48		50		52		ns	
41	t_{AWD}	Col. Address to \overline{WE} Delay	35		38		41		42		ns	12
42	t_{PC}	EDO Page Mode Read or Write Cycle Time	14		15		17		19		ns	
43	t_{CP}	\overline{CAS} Precharge Time	4		5		6		7		ns	
44	t_{CAR}	Column Address to \overline{RAS} Setup Time	18		20		22		24		ns	
45	t_{CAP}	Access Time from Column Precharge		21		23		25		27	ns	7
46	t_{DHR}	Data in Hold Time Referenced to \overline{RAS}	28		30		35		40		ns	
47	t_{CSR}	\overline{CAS} Setup Time \overline{CAS} -before- \overline{RAS} Refresh	10		10		10		10		ns	
48	t_{RPC}	\overline{RAS} to \overline{CAS} Precharge Time	0		0		0		0		ns	
49	t_{CHR}	\overline{CAS} Hold Time \overline{CAS} -before- \overline{RAS} Refresh	8		8		10		12		ns	
50	t_{PCM}	EDO Page Mode Read-Modify-Write Cycle Time	58		60		65		70		ns	
51	t_T	Transition Time (Rise and Fall)	3	50	3	50	3	50	3	50	ns	15
52	t_{REF}	Refresh Interval (1024 Cycles)		16		16		16		16	ms	
53	t_{COH}	Output Hold After \overline{CAS} Low		5		5		5		5	ns	

Notes:

1. I_{CC} is dependent on output loading when the device output is selected. Specified I_{CC} (max.) is measured with the output open.
2. I_{CC} is dependent upon the number of address transitions. Specified I_{DD} (max.) is measured with a maximum of two transitions per address cycle in EDO Page Mode.
3. Specified V_{IL} (min.) is steady state operating. During transitions, V_{IL} (min.) may undershoot to -1.0 V for a period not to exceed 20 ns. All AC parameters are measured with V_{IL} (min.) $\geq V_{SS}$ and V_{IH} (max.) $\leq V_{DD}$.
4. t_{RCD} (max.) is specified for reference only. Operation within t_{RCD} (max.) limits insures that t_{RAC} (max.) and t_{CAA} (max.) can be met. If t_{RCD} is greater than the specified t_{RCD} (max.), the access time is controlled by t_{CAA} and t_{CAC} .
5. Either t_{RRH} or t_{RCH} must be satisfied for a Read Cycle to occur.
6. Measured with a load equivalent to two TTL inputs and 50 pF.
7. Access time is determined by the longest of t_{CAA} , t_{CAC} and t_{CAP} .
8. Assumes that $t_{RAD} \leq t_{RAD}$ (max.). If t_{RAD} is greater than t_{RAD} (max.), t_{RAC} will increase by the amount that t_{RAD} exceeds t_{RAD} (max.).
9. Assumes that $t_{RCD} \leq t_{RCD}$ (max.). If t_{RCD} is greater than t_{RCD} (max.), t_{RAC} will increase by the amount that t_{RCD} exceeds t_{RCD} (max.).
10. Assumes that $t_{RAD} \geq t_{RAD}$ (max.).
11. Operation within the t_{RAD} (max.) limit ensures that t_{RAC} (max.) can be met. t_{RAD} (max.) is specified as a reference point only. If t_{RAD} is greater than the specified t_{RAD} (max.) limit, the access time is controlled by t_{CAA} and t_{CAC} .
12. t_{WCS} , t_{RWD} , t_{AWD} and t_{CWD} are not restrictive operating parameters.
13. t_{WCS} (min.) must be satisfied in an Early Write Cycle.
14. t_{DS} and t_{DH} are referenced to the latter occurrence of \overline{CAS} or \overline{WE} .
15. t_T is measured between V_{IH} (min.) and V_{IL} (max.). AC-measurements assume $t_T = 3$ ns.
16. Assumes a three-state test load (5 pF and a 380 Ohm Thevenin equivalent).
17. An initial 200 μ s pause and 8 \overline{RAS} -containing cycles are required when exiting an extended period of bias without clocks. An extended period of time without clocks is defined as one that exceeds the specified Refresh Interval.

Waveforms of Read Cycle

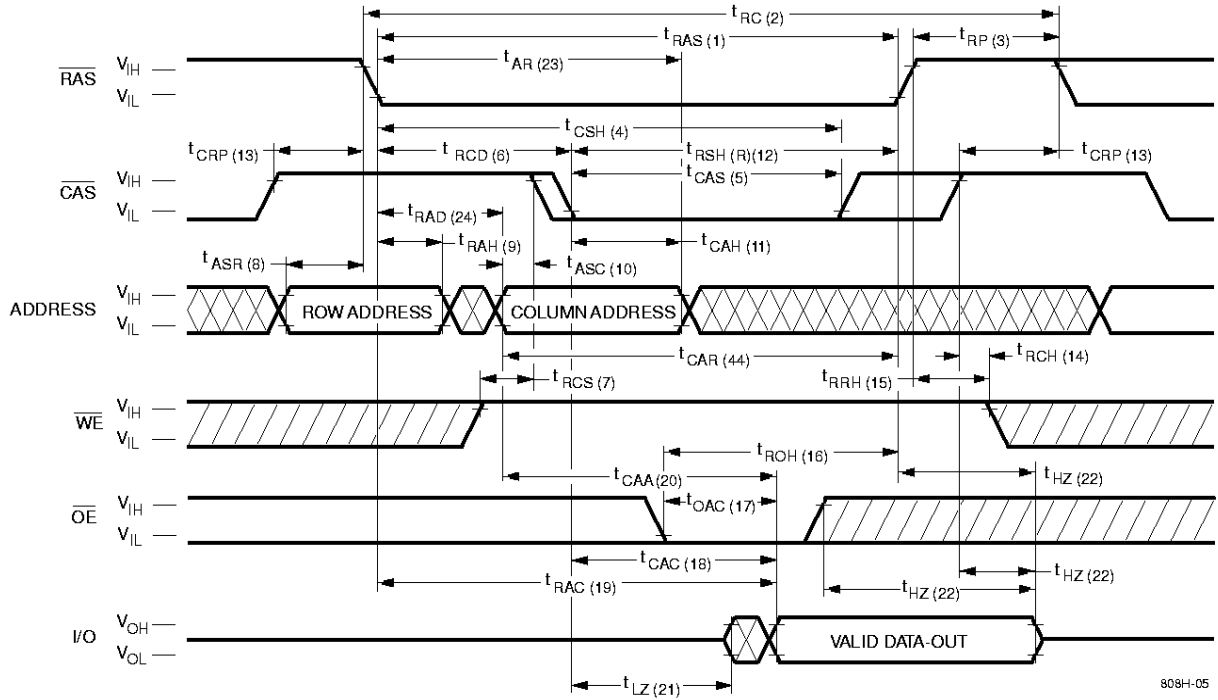

808H-05

Waveforms of Early Write Cycle

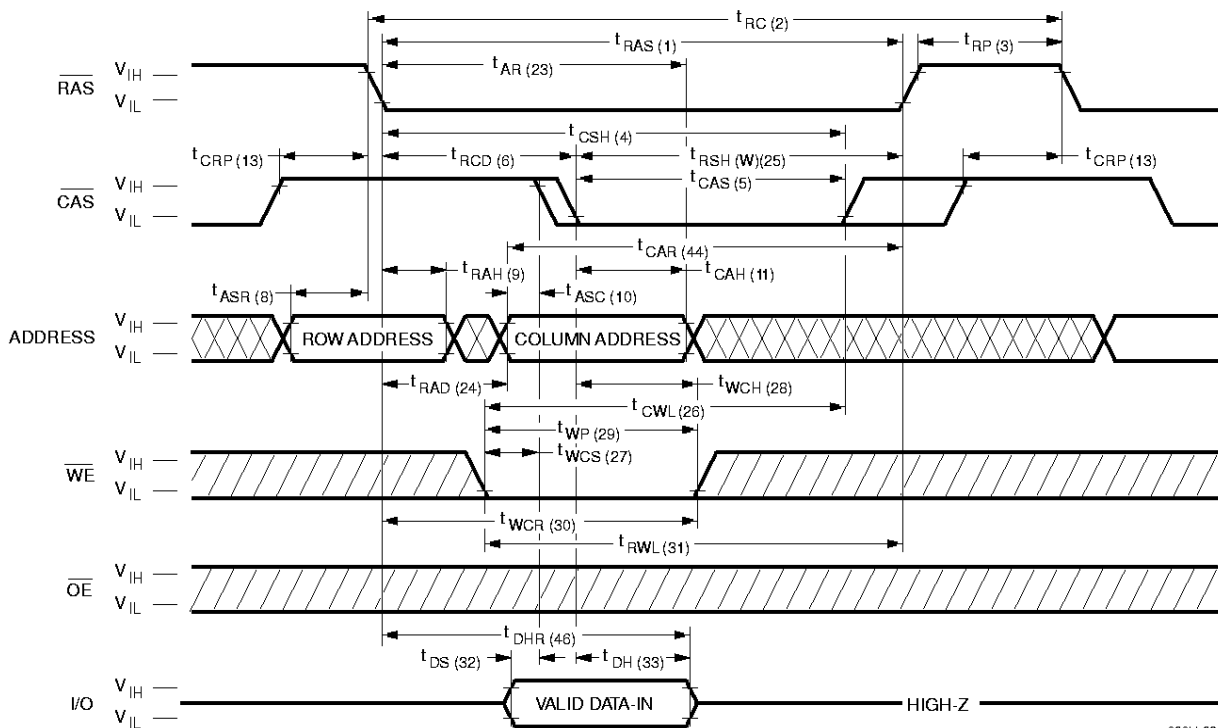

808H-06

XXXX Don't Care / / Undefined

Waveforms of \overline{OE} -Controlled Write Cycle

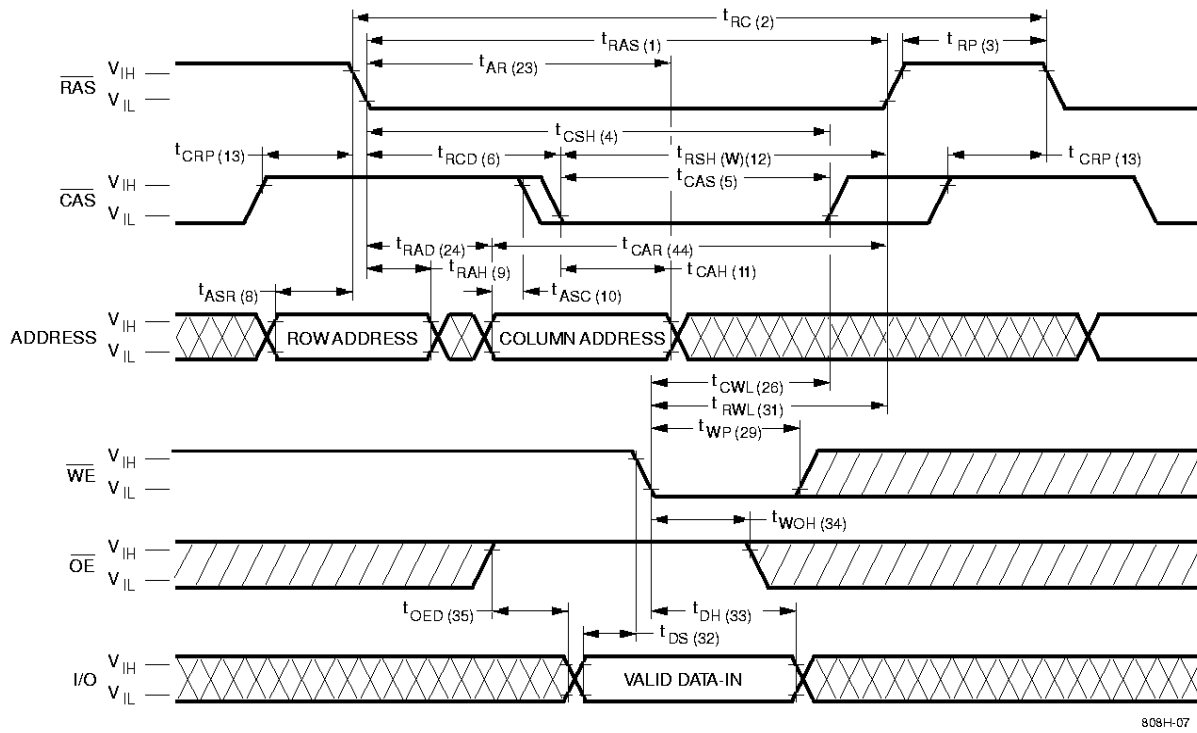

808H-07

Waveforms of Read-Modify-Write Cycle

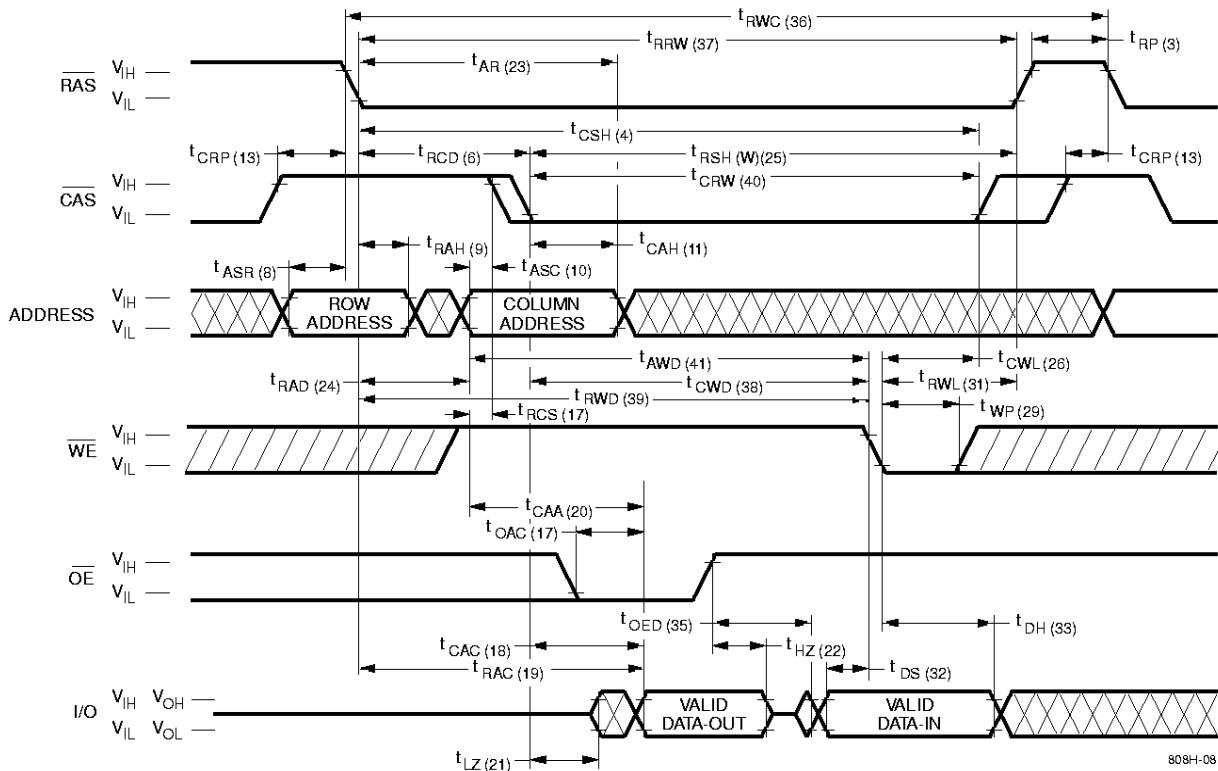

808H-08

XXXX Don't Care / / / Undefined

Waveforms of EDO Page Mode Read Cycle

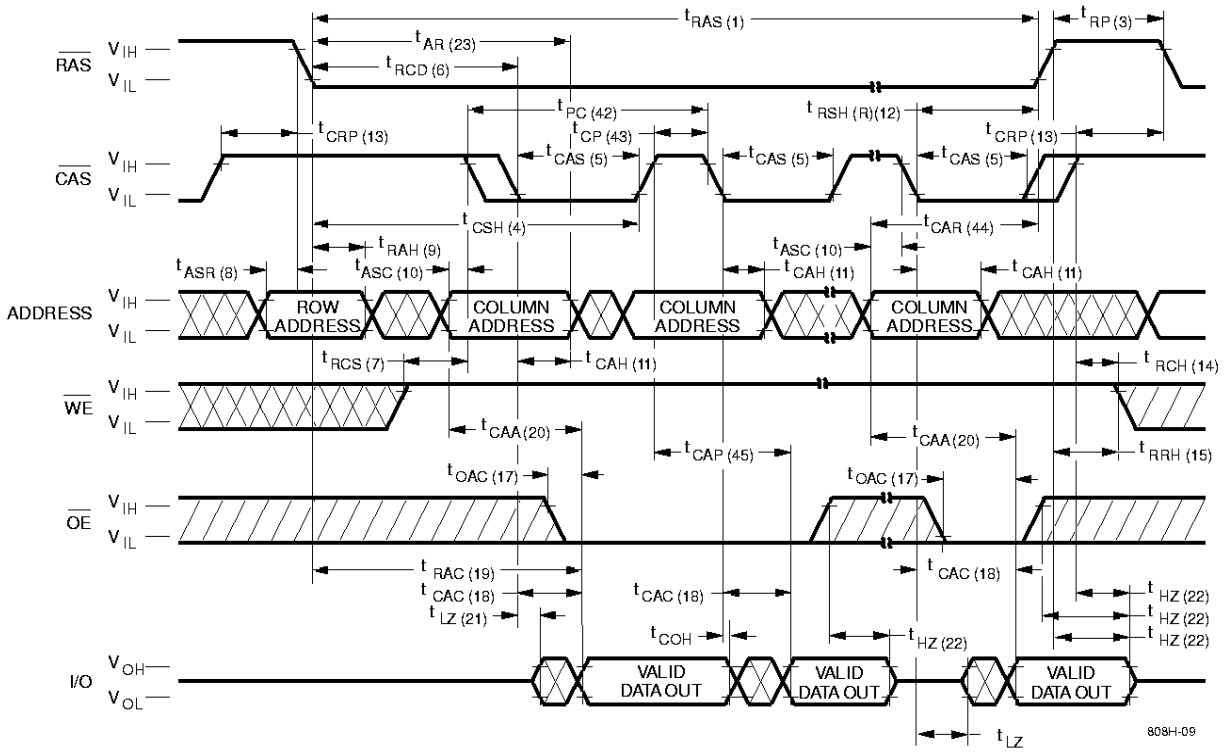

808H-09

Waveforms of EDO Page Mode Write Cycle

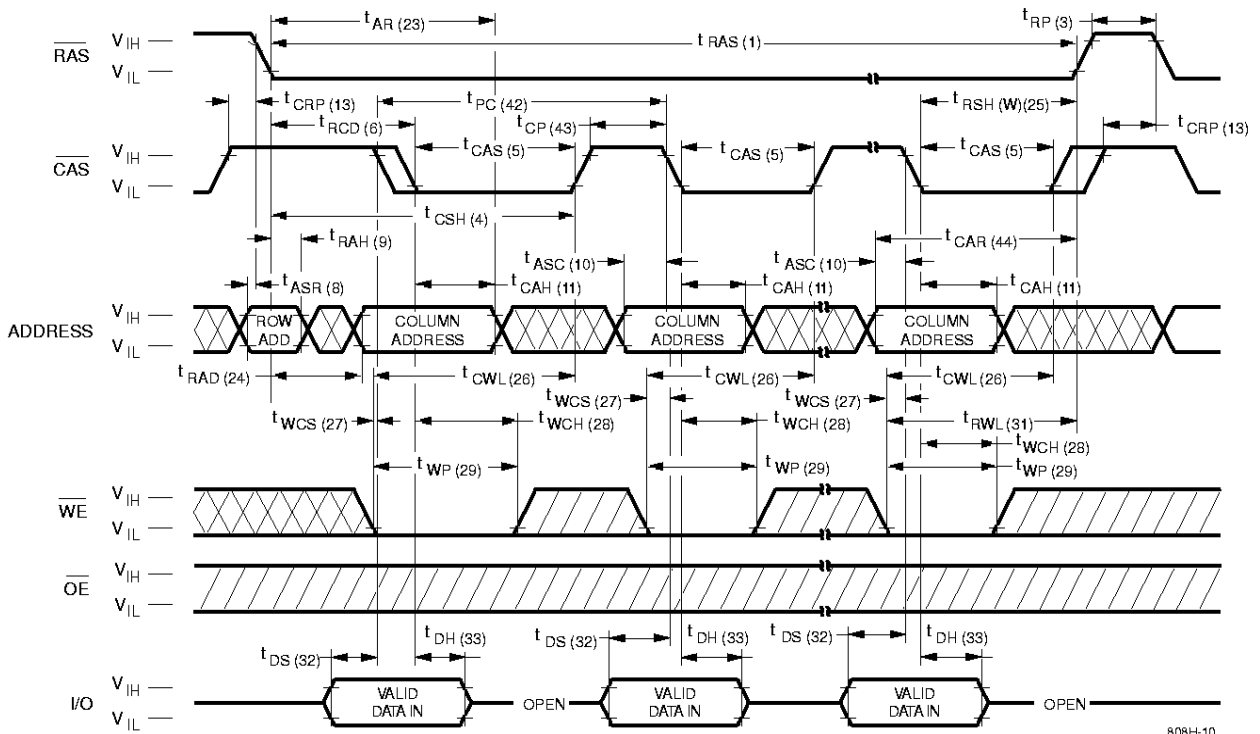

808H-10

XXX Don't Care / Undefined

Waveforms of EDO Page Mode Read-Write Cycle

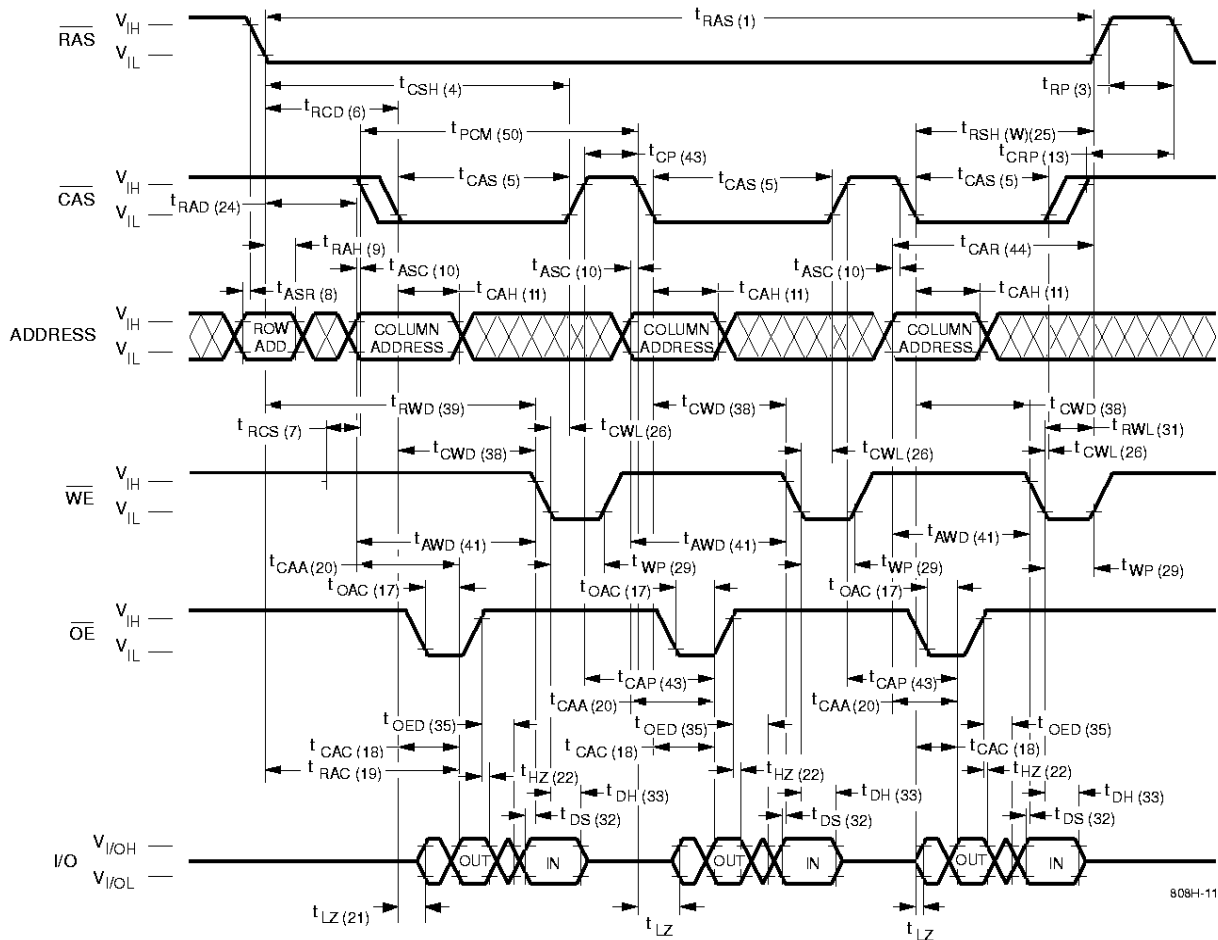

808H-11

Waveforms of RAS-Only Refresh Cycle

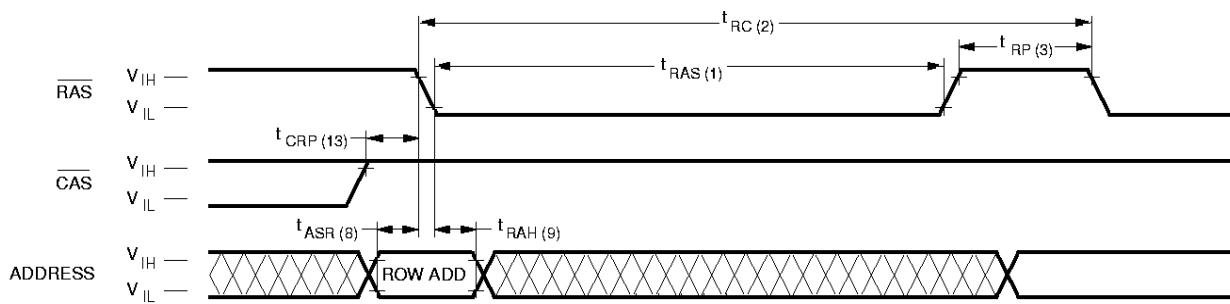

808H-12

NOTE: $\overline{WE}, \overline{OE}$ = Don't care

XXX Don't Care ZZZ Undefined

Waveforms of $\overline{\text{CAS}}$ -before- $\overline{\text{RAS}}$ Refresh Counter Test Cycle

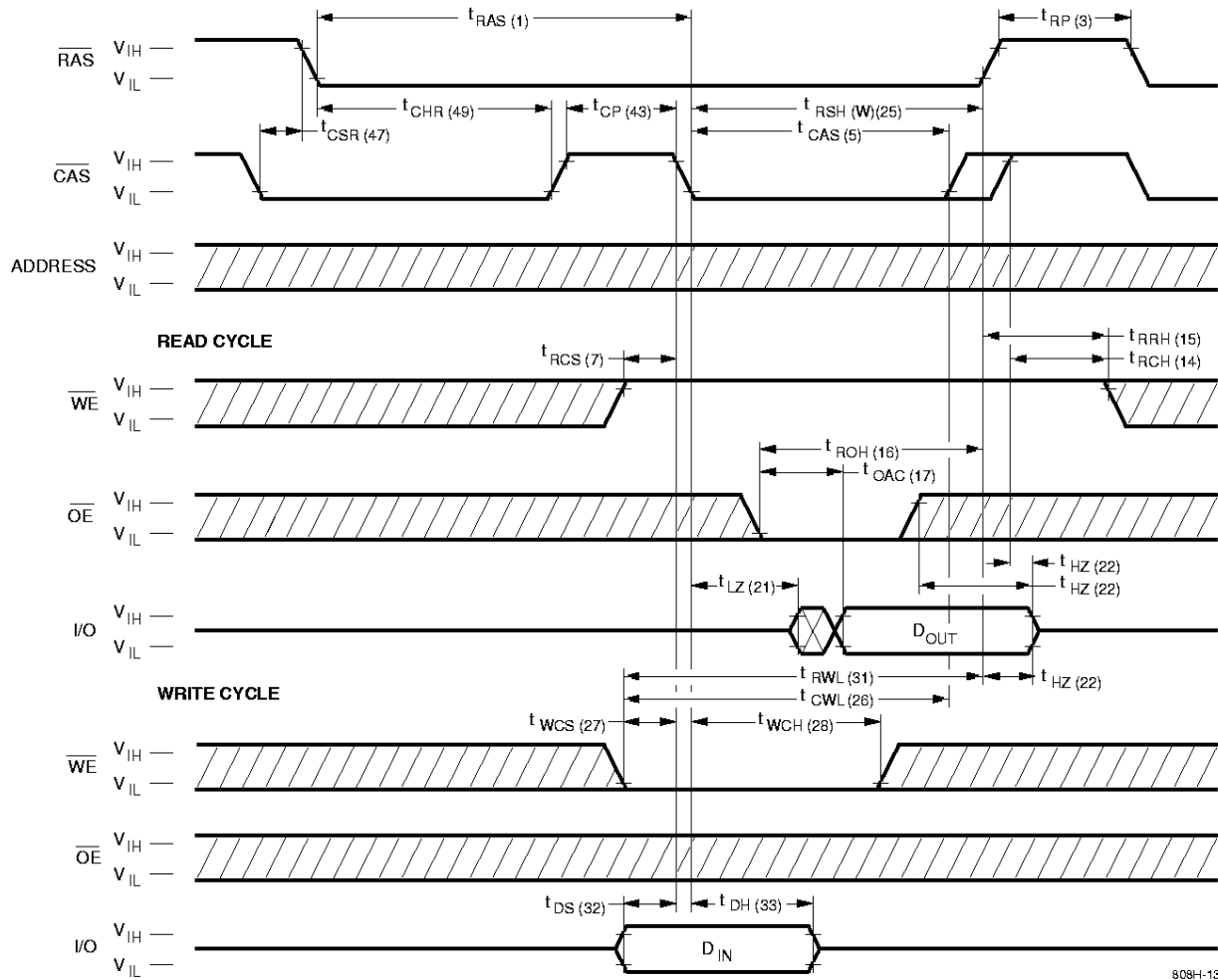

808H-13

Waveforms of $\overline{\text{CAS}}$ -before- $\overline{\text{RAS}}$ Refresh Cycle

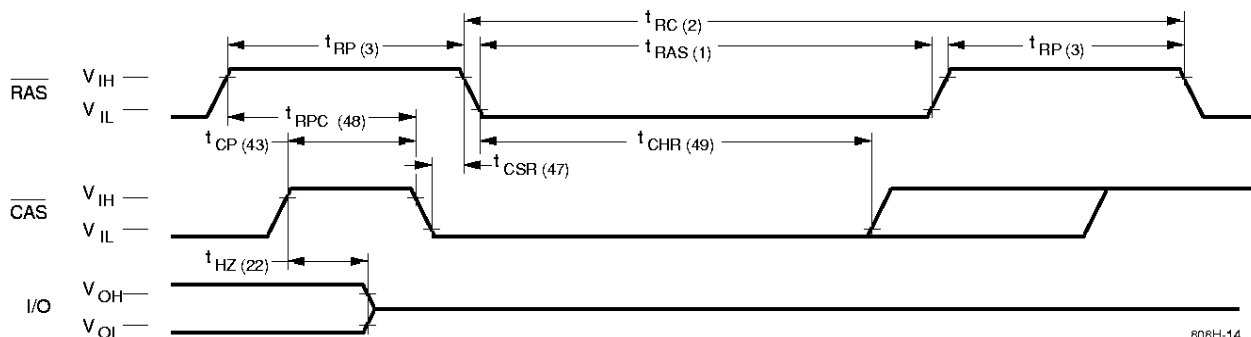

808H-14

NOTE: $\overline{\text{WE}}$, $\overline{\text{OE}}$, A_0 - A_9 = Don't care

XXX Don't Care / / / Undefined

Waveforms of Hidden Refresh Cycle (Read)

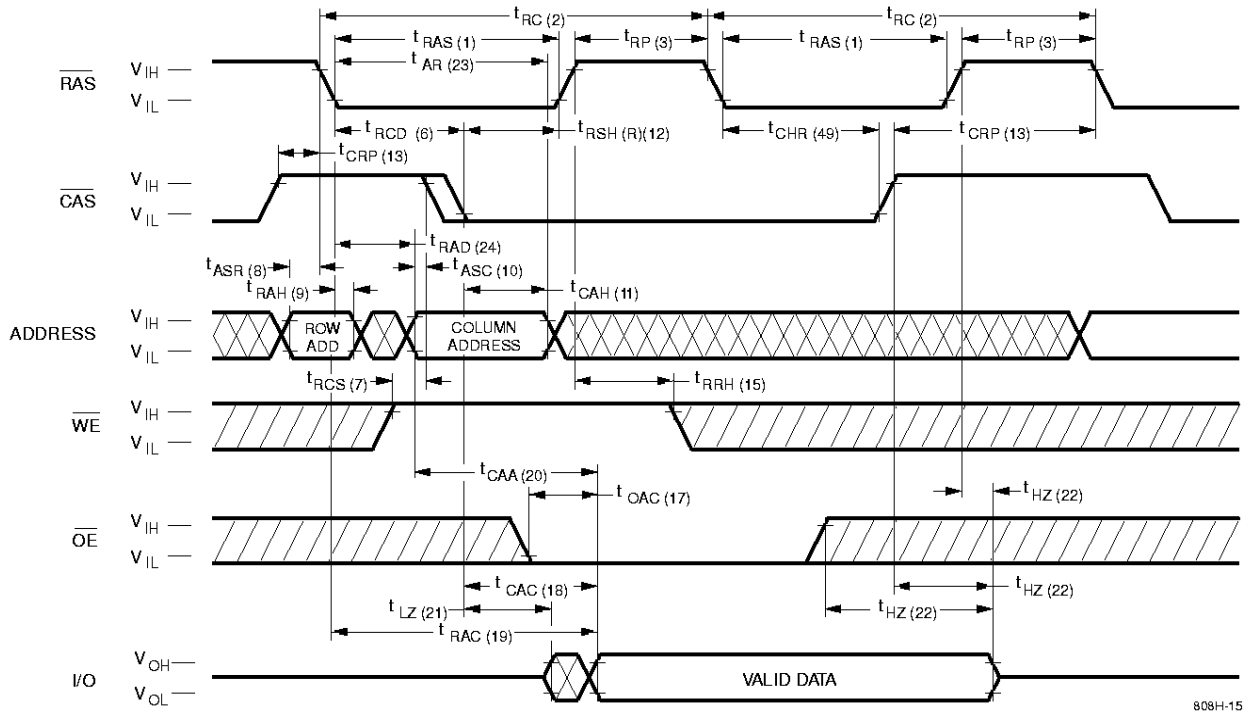

Waveforms of Hidden Refresh Cycle (Write)

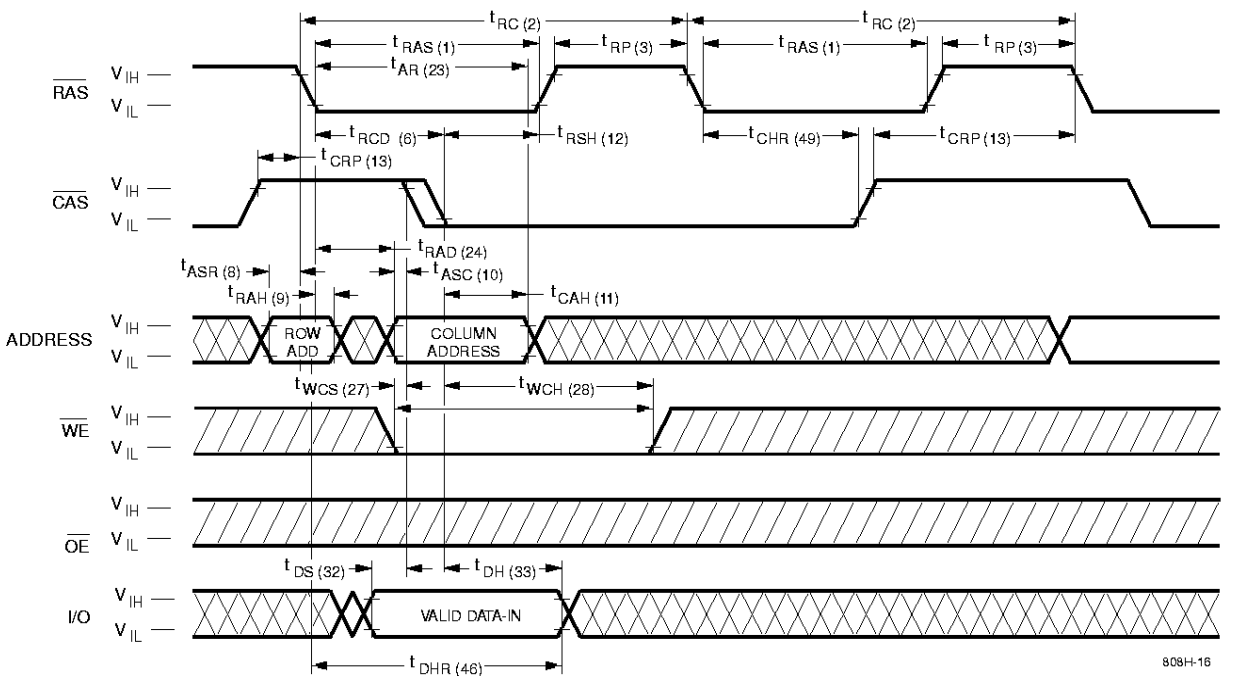

XXXX Don't Care // Undefined

Functional Description

The V53C808L is a CMOS dynamic RAM optimized for high data bandwidth, low power applications. It is functionally similar to a traditional dynamic RAM. The V53C808L reads and writes data by multiplexing an 20-bit address into a 10-bit row and a 10-bit column address. The row address is latched by the Row Address Strobe (\overline{RAS}). The column address "flows through" an internal address buffer and is latched by the Column Address Strobe (\overline{CAS}). Because access time is primarily dependent on a valid column address rather than the precise time that the \overline{CAS} edge occurs, the delay time from \overline{RAS} to \overline{CAS} has little effect on the access time.

Memory Cycle

A memory cycle is initiated by bringing \overline{RAS} low. Any memory cycle, once initiated, must not be ended or aborted before the minimum t_{RAS} time has expired. This ensures proper device operation and data integrity. A new cycle must not be initiated until the minimum precharge time t_{RP}/t_{CP} has elapsed.

Read Cycle

A Read cycle is performed by holding the Write Enable (\overline{WE}) signal High during a $\overline{RAS}/\overline{CAS}$ operation. The column address must be held for a minimum specified by t_{AR} . Data Out becomes valid only when t_{OAC} , t_{RAC} , t_{CAA} and t_{CAC} are all satisfied. As a result, the access time is dependent on the timing relationships between these parameters. For example, the access time is limited by t_{CAA} when t_{RAC} , t_{CAC} and t_{OAC} are all satisfied.

Write Cycle

A Write Cycle is performed by taking \overline{WE} and \overline{CAS} low during a \overline{RAS} operation. The column address is latched by \overline{CAS} . The Write Cycle can be \overline{WE} controlled or \overline{CAS} controlled depending on whether \overline{WE} or \overline{CAS} falls later. Consequently, the input data must be valid at or before the falling edge of \overline{WE} or \overline{CAS} , whichever occurs last. In the \overline{CAS} -controlled Write Cycle, when the leading edge of \overline{WE} occurs prior to the \overline{CAS} low transition, the I/O data pins will be in the High-Z state at the beginning of the Write function. Ending the Write with \overline{RAS} or \overline{CAS} will maintain the output in the High-Z state.

In the \overline{WE} controlled Write Cycle, \overline{OE} must be in the high state and t_{OED} must be satisfied.

Extended Data Output Page Mode

The V53C808L offers fast access within a row. Unlike ordinary fast page mode DRAM, the V53C808H output remains active and valid even after \overline{CAS} goes high and it will stay valid for 5 ns after \overline{CAS} changes low. This feature allows the V53C808H to \overline{CAS} cycle faster than ordinary page mode DRAM since the cycle time can be short as data access time.

The outputs are disabled at the t_{HZ} time after \overline{RAS} and \overline{CAS} are high. The t_{HZ} time is referenced from rising edge of \overline{RAS} or \overline{CAS} whichever occurs last. In addition, high on \overline{OE} input and activation of the write-cycle will also disable the outputs.

The following equation can be used to calculate the maximum data rate:

$$\text{Data Rate} = \frac{1024}{t_{RC} + 1023 \times t_{PC}}$$

Data Output Operation

The V53C808L Input/Output is controlled by \overline{OE} , \overline{CAS} , \overline{WE} and \overline{RAS} . A \overline{RAS} low transition enables the transfer of data to and from the selected row address in the Memory Array. A \overline{RAS} high transition disables data transfer and latches the output data if the output is enabled. After a memory cycle is initiated with a \overline{RAS} low transition, a \overline{CAS} low transition enables the internal I/O path. A \overline{CAS} high transition or \overline{RAS} high transition, whichever occurs later, disables the I/O path and the output driver if it is enabled. A \overline{CAS} low transition while \overline{RAS} is high has no effect on the I/O data path or on the output drivers. The output drivers, when otherwise enabled, can be disabled by holding \overline{OE} high. The \overline{OE} signal has no effect on any data stored in the output latches. A \overline{WE} low level can also disable the output drivers. During a Write cycle, if \overline{WE} goes low at a time when the \overline{CAS} is low, it is necessary to use \overline{OE} to disable the output drivers prior to the \overline{WE} low transition to allow Data In Setup Time (t_{DS}) to be satisfied.

To retain data, 1024 Refresh Cycles are required in each 16 ms period. There are two ways to refresh the memory:

1. By clocking each of the 1024 row addresses (A_0 through A_9) with \overline{RAS} at least once every 16 ms. Any Read, Write, Read-Modify-Write or \overline{RAS} -only cycle refreshes the addressed row.
2. Using a \overline{CAS} -before- \overline{RAS} Refresh Cycle. If \overline{CAS} makes a transition from low to high to low after the previous cycle and before \overline{RAS} falls, \overline{CAS} -before- \overline{RAS} refresh is activated. The V53C808H uses the output of an internal 10-bit counter as the source of row addresses and ignore external address inputs.

\overline{CAS} -before- \overline{RAS} is a "refresh-only" mode and no data access or device selection is allowed. Thus, the output remains in the High-Z state during the cycle. A \overline{CAS} -before- \overline{RAS} counter test mode is provided to ensure reliable operation of the internal refresh counter.

Power-On

After application of the V_{CC} supply, an initial pause of 200 μ s is required followed by a minimum of 8 initialization cycles (any combination of cycles containing a \overline{RAS} clock). Eight initialization cycles are required after extended periods of bias without clocks (greater than the Refresh Interval).

During Power-On, the V_{CC} current requirement of the V53C808L is dependent on the input levels of \overline{RAS} and \overline{CAS} . If \overline{RAS} is low during Power-On, the device will go into an active cycle and I_{CC} will exhibit current transients. It is recommended that \overline{RAS} and \overline{CAS} track with V_{CC} or be held at a valid V_{IH} during Power-On to avoid current surges.

Table 1. V53C808L Data Output Operation for Various Cycle Types

Cycle Type	I/O State
Read Cycles	Data from Addressed Memory Cell
\overline{WE} -Controlled Write Cycle (Early Write)	High-Z
\overline{OE} -Controlled Write Cycle (Late Write)	\overline{OE} Controlled. High \overline{OE} = High-Z I/Os
Read-Modify-Write Cycles	Data from Addressed Memory Cell
EDO Page Mode Read	Data from Addressed Memory Cell
EDO Page Mode Write Cycle (Early Write)	High-Z
EDO Read-Modify-Write Cycle	Data from Addressed Memory Cell
\overline{RAS} -only Refresh	High-Z
\overline{CAS} -before- \overline{RAS} Refresh Cycle	High-z

Package Diagrams

28-Pin Plastic SOJ

Unit in inches [mm]

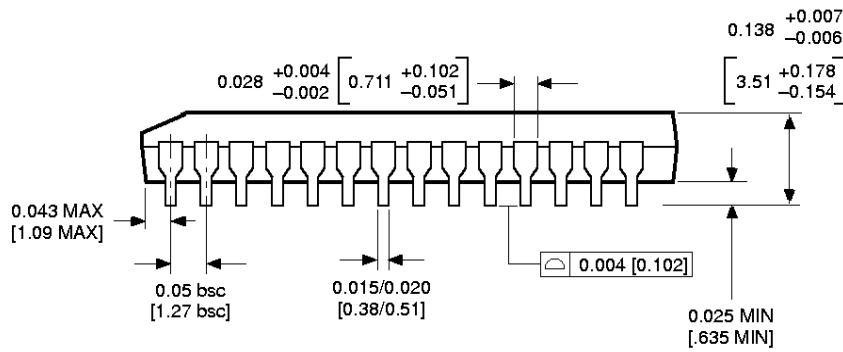
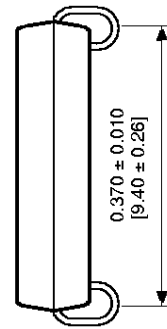
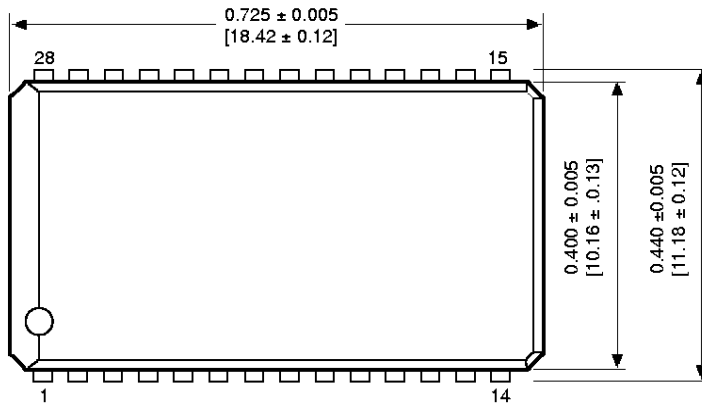

28-Pin Plastic TSOP-II

Units in mm

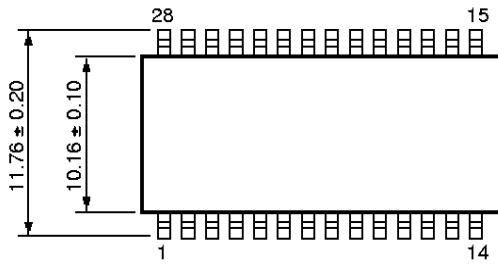

Detail -A-

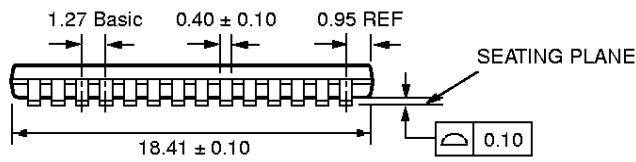
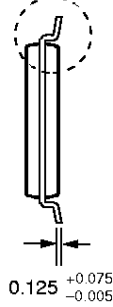

Detail -A-

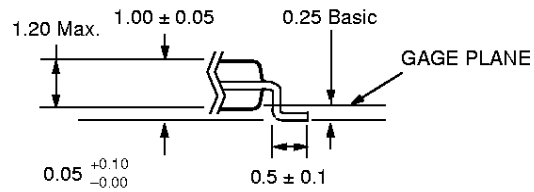

U.S.A.

3910 NORTH FIRST STREET
SAN JOSE, CA 95134
PHONE: 408-433-6000
FAX: 408-433-0185

HONG KONG

19 DAI FU STREET
TAIPO INDUSTRIAL ESTATE
TAIPO, NT, HONG KONG
PHONE: 852-2665-4883
FAX: 852-2664-7535

TAIWAN

7F, NO. 102
MIN-CHUAN E. ROAD, SEC. 3
TAIPEI
PHONE: 886-2-2545-1213
FAX: 886-2-2545-1209

1 CREATION ROAD I
SCIENCE BASED IND. PARK
HSIN CHU, TAIWAN, R.O.C.
PHONE: 886-3-578-3344
FAX: 886-3-579-2838

JAPAN

WBG MARINE WEST 25F
6, NAKASE 2-CHOME
MIHAMA-KU, CHIBA-SHI
CHIBA 261-71
PHONE: 81-43-299-6000
FAX: 81-43-299-6555

IRELAND & UK

BLOCK A UNIT 2
BROOMFIELD BUSINESS PARK
MALAHIDE
CO. DUBLIN, IRELAND
PHONE: +353 1 8038020
FAX: +353 1 8038049

**GERMANY
(CONTINENTAL
EUROPE & ISRAEL)**

71083 HERRENBERG
BENZSTR. 32
GERMANY
PHONE: +49 7032 2796-0
FAX: +49 7032 2796 22

U.S. SALES OFFICES**NORTHWESTERN**

3910 NORTH FIRST STREET
SAN JOSE, CA 95134
PHONE: 408-433-6000
FAX: 408-433-0185

SOUTHWESTERN

SUITE 200
5150 E. PACIFIC COAST HWY.
LONG BEACH, CA 90804
PHONE: 562-498-3314
FAX: 562-597-2174

CENTRAL & SOUTHEASTERN

604 FIELDWOOD CIRCLE
RICHARDSON, TX 75081
PHONE: 972-690-1402
FAX: 972-690-0341

NORTHEASTERN

SUITE 436
20 TRAFALGAR SQUARE
NASHUA, NH 03063
PHONE: 603-889-4393
FAX: 603-889-9347

The information in this document is subject to change without notice.

MOSEL VITELIC makes no commitment to update or keep current the information contained in this document. No part of this document may be copied or reproduced in any form or by any means without the prior written consent of MOSEL-VITELIC.

MOSEL VITELIC subjects its products to normal quality control sampling techniques which are intended to provide an assurance of high quality products suitable for usual commercial applications. MOSEL VITELIC does not do testing appropriate to provide 100% product quality assurance and does not assume any liability for consequential or incidental arising from any use of its products. If such products are to be used in applications in which personal injury might occur from failure, purchaser must do its own quality assurance testing appropriate to such applications.