

FHX13LG/LP, 14LG/LP

Super Low Noise HEMT

FEATURES

- Low Noise Figure: 0.45dB (Typ.)@f=12GHz (FHX13)
- High Associated Gain: 13.0dB (Typ.)@f=12GHz
- $L_g \leq 0.15\mu\text{m}$, $W_g = 200\mu\text{m}$
- Gold Gate Metallization for High Reliability
- Cost Effective Ceramic Microstrip (SMT) Package
- Tape and Reel Packaging Available

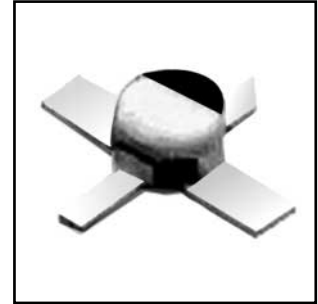

DESCRIPTION

The FHX13LG/LP, FHX14LG/LP is a Super High Electron Mobility Transistor(SuperHEMT) intended for general purpose, ultra-low noise and high gain amplifiers in the 2-18GHz frequency range. The devices are packaged in cost effective, low parasitic, hermetically sealed(LG) or epoxy-sealed(LP) metal-ceramic packages for high volume telecommunication, DBS, TVRO, VSAT or other low noise applications.

Fujitsu's stringent Quality Assurance Program assures the highest reliability and consistent performance.

ABSOLUTE MAXIMUM RATING (Ambient Temperature $T_a=25^\circ\text{C}$)

Item	Symbol	Rating	Unit
Drain-Source Voltage	V_{DS}	3.5	V
Gate-Source Voltage	V_{GS}	-3.0	V
Total Power Dissipation	P_t^*	180	mW
Storage Temperature	FHX13LG	-65 to +175	$^\circ\text{C}$
	FHX13LP	-65 to +150	$^\circ\text{C}$
Channel Temperature	FHX14LG	175	$^\circ\text{C}$
	FHX14LP	150	$^\circ\text{C}$

*Note: Mounted on Al_2O_3 board (30 x 30 x 0.65mm)

Fujitsu recommends the following conditions for the reliable operation of GaAs FETs:

1. The drain-source operating voltage (V_{DS}) should not exceed 2 volts.
2. The forward and reverse gate currents should not exceed 0.2 and -0.05 mA respectively with gate resistance of 4000 Ω .
3. The operating channel temperature (T_{ch}) should not exceed 80 $^\circ\text{C}$.

ELECTRICAL CHARACTERISTICS (Ambient Temperature $T_a=25^\circ\text{C}$)

Item	Symbol	Condition	Limit			Unit
			Min.	Typ.	Max.	
Saturated Drain Current	I_{DSS}	$V_{DS} = 2\text{V}, V_{GS} = 0\text{V}$	10	30	60	mA
Transconductance	g_m	$V_{DS} = 2\text{V}, I_{DS} = 10\text{mA}$	35	50	-	mS
Pinch-off Voltage	V_p	$V_{DS} = 2\text{V}, I_{DS} = 1\text{mA}$	-0.1	-0.7	-1.5	V
Gate Source Breakdown Voltage	V_{GSO}	$I_{GS} = -10\mu\text{A}$	-3.0	-	-	V
Noise Figure	NF	$V_{DS} = 2\text{V}, I_{DS} = 10\text{mA}, f = 12\text{GHz}$	-	0.45	0.50	dB
Associated Gain			G_{as}	11.0	13.0	-
Noise Figure	NF	$V_{DS} = 2\text{V}, I_{DS} = 10\text{mA}, f = 12\text{GHz}$	-	0.55	0.60	dB
Associated Gain			G_{as}	11.0	13.0	-
Thermal Resistance	R_{th}	Channel to Case	-	300	400	$^\circ\text{C}/\text{W}$

AVAILABLE CASE STYLES: LG/LP

Note: RF parameters for LG/LP devices are measured on a sample basis as follows:

Lot qty.	Sample qty.	Accept/Reject
1200 or less	125	(0,1)
1201 to 3200	200	(0,1)
3201 to 10000	315	(1,2)
10001 or over	500	(1,2)

FHX13LG/LP, 14LG/LP

Super Low Noise HEMT

POWER DERATING CURVE

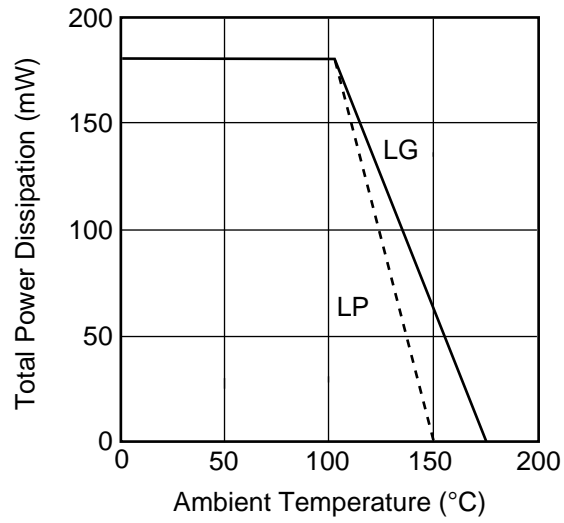

DRAIN CURRENT vs. DRAIN-SOURCE VOLTAGE

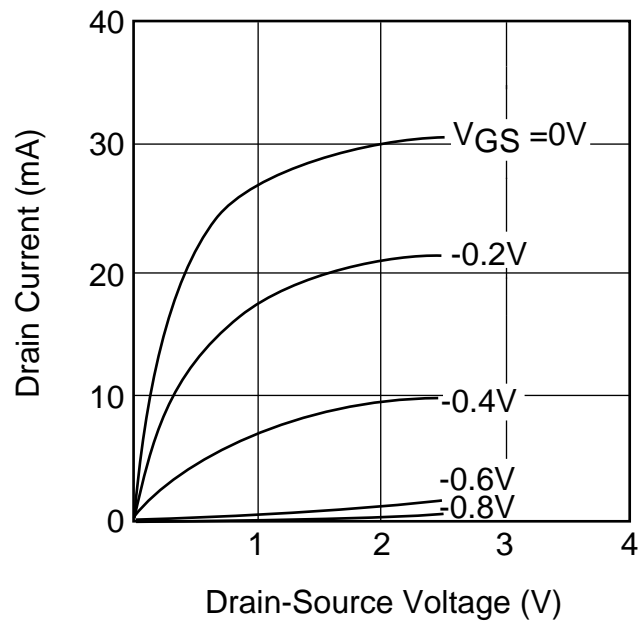

FHX13LG/LP, 14LG/LP

Super Low Noise HEMT

NF & Gas vs. FREQUENCY
FHX13LG

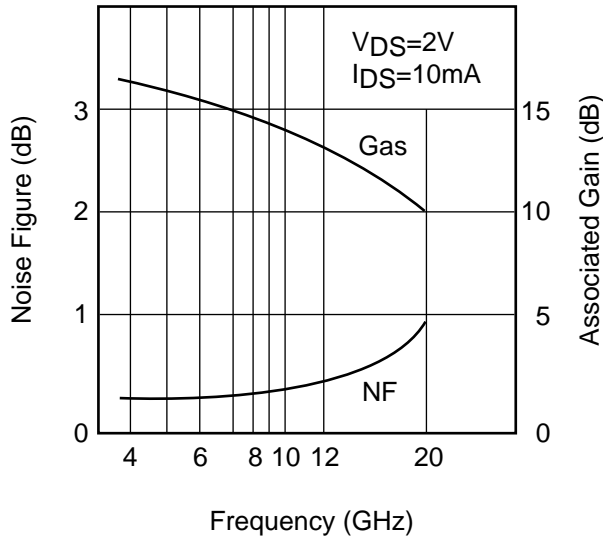

NF & Gas vs. I_{DS}
FHX13LG/LP

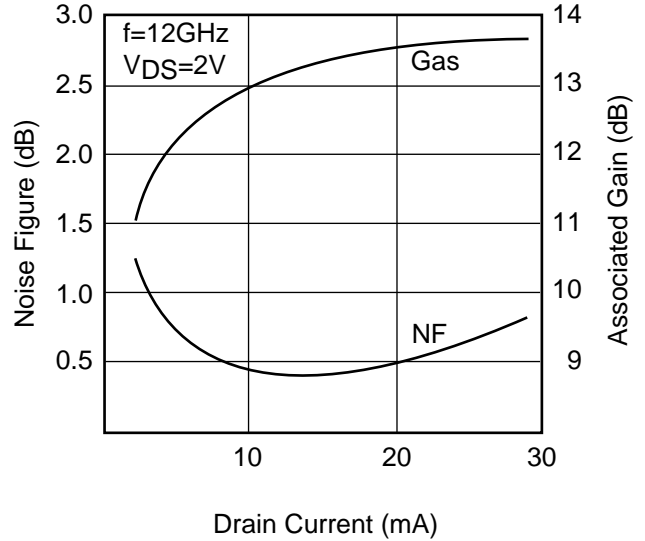

NF & Gas vs. TEMPERATURE
FHX13LG/LP

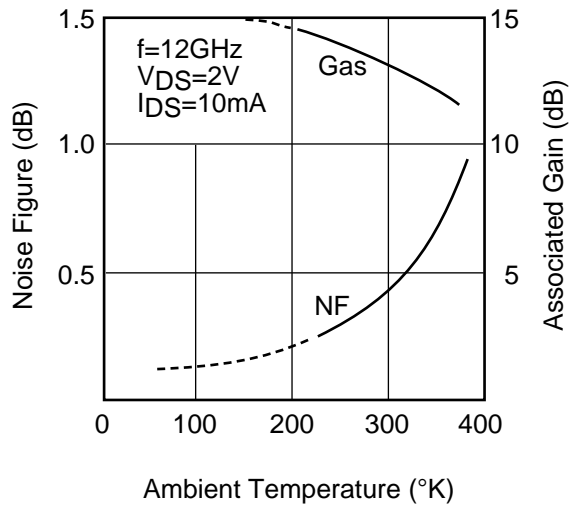

OUTPUT POWER vs. INPUT POWER
FHX13LG

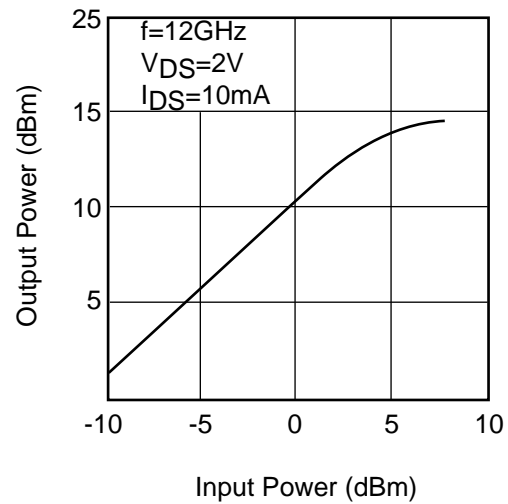

FHX13LG/LP, 14LG/LP

Super Low Noise HEMT

TYPICAL NOISE FIGURE CIRCLE FHX13LG

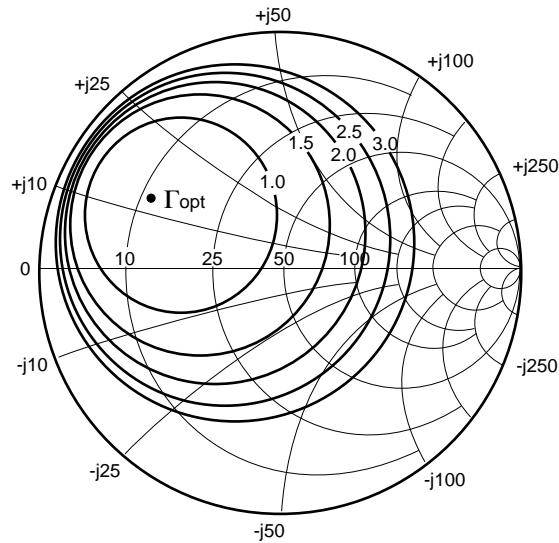

f = 12 GHz
V_{DS} = 2V
I_{DS} = 10mA

Γ_{opt} = 0.61 ∠ 150°
R_n/50 = 0.04
NF_{min} = 0.45dB

NOISE PARAMETERS FHX13LG V_{DS}=2V, I_{DS}=10mA

Freq. (GHz)	Γ _{opt}		NF _{min} (dB)	R _n /50
	(MAG)	(ANG)		
2	0.96	29	0.33	0.22
4	0.92	57	0.34	0.20
6	0.86	83	0.35	0.15
8	0.79	107	0.37	0.11
10	0.71	129	0.40	0.07
12	0.61	150	0.45	0.04
14	0.50	168	0.53	0.04
16	0.38	-175	0.63	0.06
18	0.24	-161	0.83	0.10

Ga(max) & |S₂₁|² vs. FREQUENCY

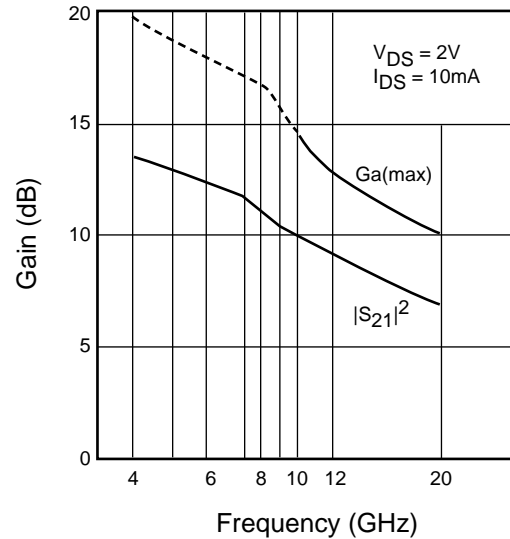

NOISE PARAMETERS FHX13LP V_{DS}=2V, I_{DS}=10mA

Freq. (GHz)	Γ _{opt}		NF _{min} (dB)	R _n /50
	(MAG)	(ANG)		
2	0.98	27	0.33	0.20
4	0.92	49	0.34	0.19
6	0.84	72	0.35	0.14
8	0.75	98	0.37	0.10
10	0.65	125	0.40	0.05
12	0.53	154	0.45	0.03
14	0.41	-176	0.53	0.04
16	0.28	-143	0.63	0.07
18	0.13	-109	0.83	0.13

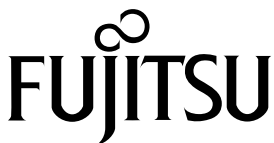

FHX13LG/LP, 14LG/LP

Super Low Noise HEMT

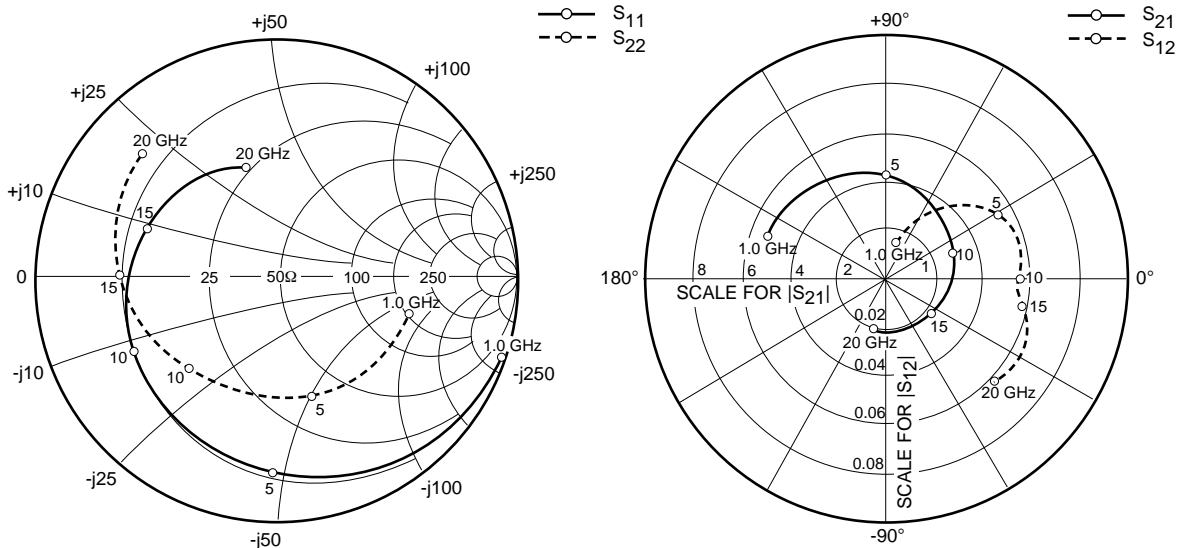

S-PARAMETERS

FHX13/14LG

$V_{DS} = 2V, I_{DS} = 10mA$

FREQUENCY (MHZ)	S11		S21		S12		S22	
	MAG	ANG	MAG	ANG	MAG	ANG	MAG	ANG
1000	0.988	-20.0	5.327	160.1	0.015	75.7	0.574	-16.3
2000	0.956	-39.5	5.133	141.0	0.028	63.3	0.560	-32.1
3000	0.908	-58.1	4.851	123.0	0.039	50.1	0.539	-47.3
4000	0.862	-75.5	4.534	105.9	0.048	39.0	0.522	-62.0
5000	0.811	-91.6	4.213	89.7	0.053	29.3	0.502	-75.6
6000	0.763	-107.1	3.886	74.4	0.056	21.0	0.488	-89.6
7000	0.727	-121.1	3.582	60.0	0.057	13.2	0.487	-103.0
8000	0.701	-133.3	3.300	46.4	0.056	7.9	0.498	-114.9
9000	0.682	-144.1	3.078	33.8	0.055	3.5	0.515	-125.0
10000	0.659	-154.2	2.899	21.4	0.055	-0.0	0.531	-134.4
11000	0.636	-164.4	2.748	9.3	0.054	-2.6	0.544	-144.0
12000	0.618	-175.4	2.593	-3.3	0.054	-5.2	0.561	-155.1
13000	0.608	175.5	2.466	-14.8	0.054	-5.7	0.590	-164.0
14000	0.596	166.6	2.366	-26.6	0.055	-7.8	0.619	-172.4
15000	0.585	158.3	2.279	-38.3	0.056	-9.7	0.654	-179.7
16000	0.564	148.8	2.244	-50.7	0.058	-12.8	0.677	172.6
17000	0.543	138.2	2.217	-63.6	0.061	-17.6	0.701	163.4
18000	0.525	127.3	2.185	-77.1	0.063	-24.7	0.727	154.1
19000	0.506	116.2	2.143	-91.4	0.063	-33.1	0.748	143.6
20000	0.470	106.5	2.089	-105.4	0.061	-43.7	0.763	137.2

FHX13LG/LP, 14LG/LP

Super Low Noise HEMT

S-PARAMETERS

FHX13/14LP

$V_{DS} = 2V, I_{DS} = 10mA$

FREQUENCY (MHZ)	S11		S21		S12		S22	
	MAG	ANG	MAG	ANG	MAG	ANG	MAG	ANG
1000	0.990	-18.4	5.504	161.6	0.016	77.7	0.597	-13.3
2000	0.957	-36.4	5.351	144.0	0.031	65.7	0.579	-26.4
3000	0.908	-54.0	5.120	126.9	0.044	54.9	0.554	-39.1
4000	0.854	-70.8	4.846	110.6	0.055	44.5	0.526	-51.4
5000	0.793	-87.1	4.555	94.9	0.064	35.2	0.494	-63.2
6000	0.732	-103.0	4.249	79.9	0.071	26.6	0.463	-75.5
7000	0.679	-117.9	3.944	65.6	0.075	18.5	0.441	-88.0
8000	0.637	-131.4	3.656	52.3	0.078	11.7	0.431	-99.6
9000	0.601	-143.5	3.417	39.7	0.082	5.8	0.430	-109.7
10000	0.564	-155.2	3.221	27.6	0.085	0.5	0.428	-119.1
11000	0.530	-167.0	3.058	15.7	0.088	-5.0	0.423	-129.0
12000	0.499	-179.8	2.895	3.5	0.090	-11.1	0.424	-140.4
13000	0.476	169.1	2.752	-8.1	0.093	-16.0	0.436	-150.7
14000	0.454	158.6	2.633	-19.6	0.096	-21.5	0.456	-160.0
15000	0.431	148.7	2.532	-31.2	0.099	-27.4	0.479	-168.2
16000	0.405	137.5	2.463	-43.0	0.104	-34.1	0.495	-176.4
17000	0.379	124.5	2.412	-55.1	0.109	-41.4	0.504	174.0
18000	0.359	112.2	2.349	-67.7	0.113	-50.0	0.519	164.0
19000	0.335	97.9	2.292	-80.7	0.117	-59.0	0.535	153.8
20000	0.305	86.5	2.226	-93.1	0.120	-68.8	0.550	146.6

Case Style "LG/LP"

Metal-Ceramic Hermetic Package

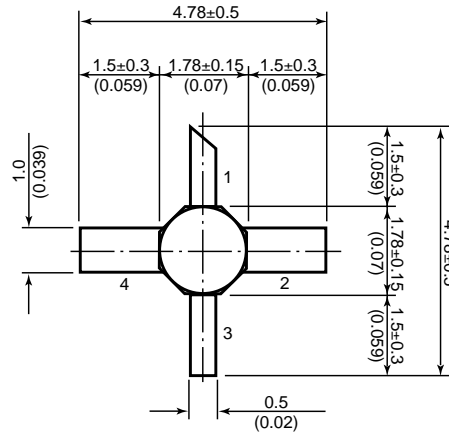

Gold Plated Leads

1. Gate
2. Source
3. Drain
4. Source

Unit: mm(inches)

For further information please contact:

FUJITSU COMPOUND SEMICONDUCTOR, INC.

2355 Zanker Rd.
San Jose, CA 95131-1138, U.S.A.
Phone: (408) 232-9500
FAX: (408) 428-9111
www.fcsi.fujitsu.com

FUJITSU MICROELECTRONICS, LTD.

Compound Semiconductor Division
Network House
Norreys Drive
Maidenhead, Berkshire SL6 4FJ
Phone:+44 (0)1628 504800
FAX:+44 (0)1628 504888

CAUTION

Fujitsu Compound Semiconductor Products contain **gallium arsenide (GaAs)** which can be hazardous to the human body and the environment. For safety, observe the following procedures:

- Do not put these products into the mouth.
- Do not alter the form of this product into a gas, powder, or liquid through burning, crushing, or chemical processing as these by-products are dangerous to the human body if inhaled, ingested, or swallowed.
- Observe government laws and company regulations when discarding this product. This product must be discarded in accordance with methods specified by applicable hazardous waste procedures.

Fujitsu Limited reserves the right to change products and specifications without notice. The information does not convey any license under rights of Fujitsu Limited or others.

© 1998 FUJITSU COMPOUND SEMICONDUCTOR, INC.

Printed in U.S.A. FCSI0598M200

SuperHEMT™ is a trademark of Fujitsu Limited.