

DRAWING NO  
C - 210792

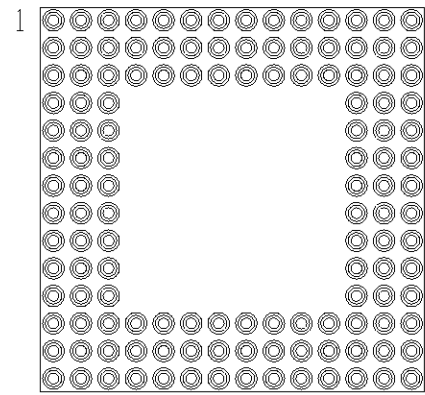

132 positions  
Ech. 1:1

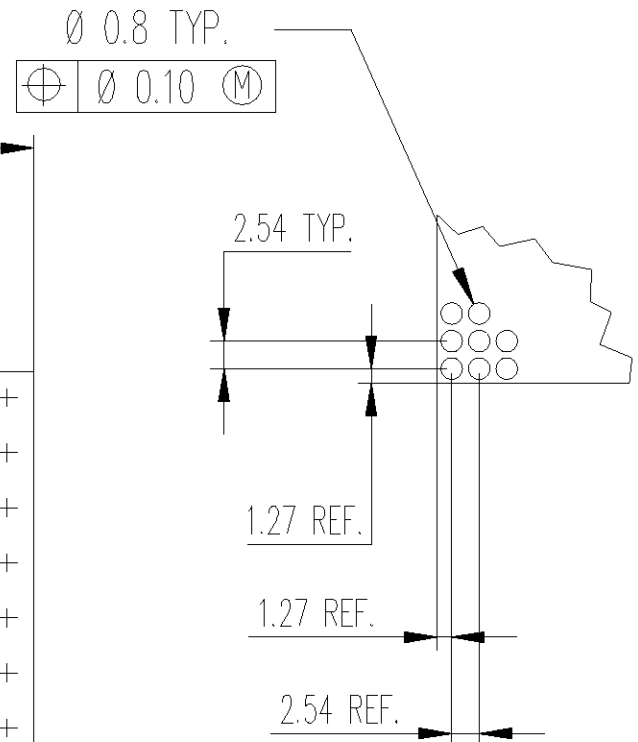
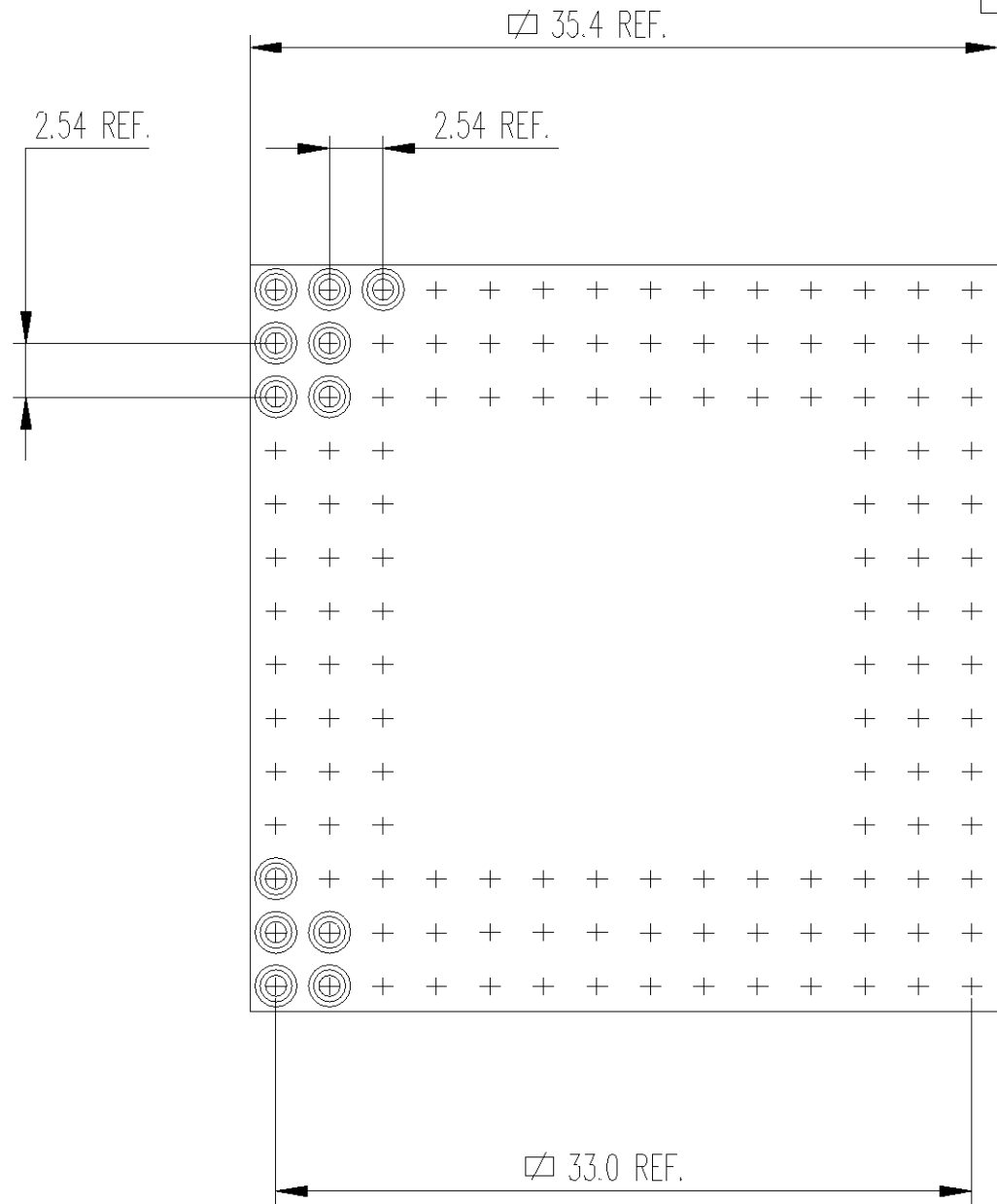
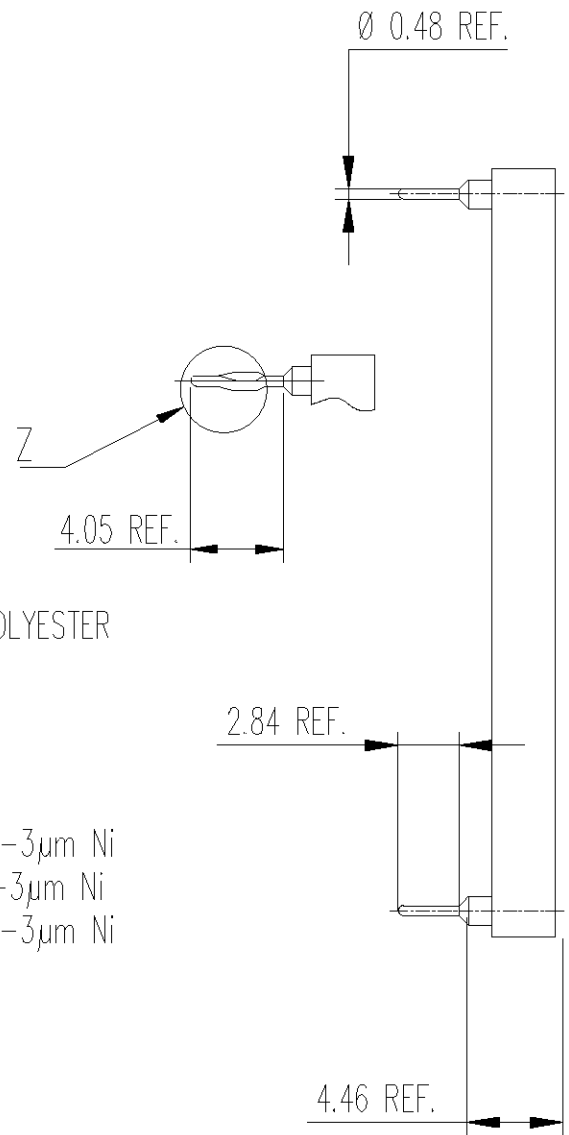

RECOMMENDED P.C.  
BOARD PATTERN

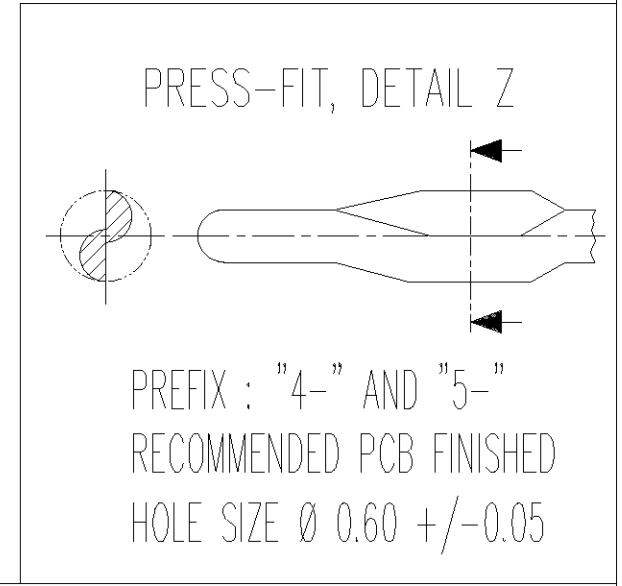

NOTE :

1. MATERIAL
  - INSULATOR : GLASSFILLED THERMOPLASTIC POLYESTER
  - SOLDER TAIL SLEEVE : BRASS
  - PRESS-FIT SLEEVE : PHOSPHOR BRONZE
  - CLIP : STAMPED BERYLLIUM COPPER
2. SLEEVE PLATING:
  - PREFIX "0-" AND "2-": 5µm Sn/Pb OVER 2-3µm Ni
  - PREFIX "1-" AND "3-": 0.25µm Au OVER 2-3µm Ni
  - PREFIX "4-" AND "5-": 3µm Sn/Pb OVER 2-3µm Ni
3. INNER CONTACT PLATING
  - SUFFIX "-1" 0.25µm 18c. Au
  - SUFFIX "-3" 0.75µm 18c. Au
  - SUFFIX "-4" 0.75µm 24c. Au
  - SUFFIX "-5" 5µm MIN. Sn/Pb \*\*
  - SUFFIX "-6" 0.1µm FLASH 24c. Au
  - SUFFIX "-7" 0.60µm 18c. Au
  - \*\* ONLY WITH PREFIX "0-", "2-", "4-" AND "5-"
4. INNER SPRING CONTACT ACCEPT Ø 0.40 TO 0.56  
OR RECTANGULAR PIN 0.25 x 0.45
5. INSERTION CHARACTERISTICS:
  - PREFIX "0-", "1-" AND "4-" : VERY LOW FORCE
  - PREFIX "2-", "3-" AND "5-" : ULTRA LOW FORCE
6. MECHANICAL DATA WITH A Ø 0.43 TEST PIN :
 

|                                    |      |       |
|------------------------------------|------|-------|
|                                    | VLI  | ULI   |
| -MAX. INSERTION FORCE :            | 0.7N | 0.2N  |
| -MIN. EXTRACTION FORCE :           | 0.1N | 0.05N |
| -MECHANICAL LIFE : 100 CYCLES MIN. |      |       |
| WAS 700-132-14-1-CC AND CCAP       |      |       |

|                 |    |      |  |     |     |      |      |           |  |  |                          |                 |                |
|-----------------|----|------|--|-----|-----|------|------|-----------|--|--|--------------------------|-----------------|----------------|
| DIMENSIONS      | mm |      |  |     |     |      |      |           | DRAWN<br>E.BRESSOUD<br>20 JUL 99       | THIS INFORMATION IS CONFIDENTIAL AND IS DISCLOSED TO YOU ON CONDITION THAT NO FUTHER DISCLOSURE IS MADE BY YOU TO OTHER THAN AMP PERSONNEL WITHOUT WRITTEN AUTHORIZATION FROM DSM SWITZERLAND. |                          |                 |                |
|                 |    |      |  |     |     |      |      |           | CHECKED<br>S.CHANDEVAVLT<br>20 JUL 99  |  |                          |                 |                |
| SURFACE TEXTURE |    |      |  |     |     |      |      |           | APPROVED                               |  |                          |                 |                |
| CONCENTRICITY   |    | 0.15 |  |     |     |      |      |           |  | NAME<br>CLOSED FRAME PGA<br>14 x 14, 132 SOCKETS   |                          |                 |                |
| PRODUCT SPEC.   |    |      | P  | REV | ECN | DRWN | DATE | APVD      | CUSTOMER DRAWING<br>FOR REFERENCE ONLY |  |                          |                 |                |
|                 |    |      | DSM DECOLLETAGE SA SAINT-MAURICE<br>CH 1890 SAINT-MAURICE (VS) |     |     |      |      | LOC<br>EK | SCALE<br>2/1                           | SIZE<br>A4   | DRAWING NO<br>C - 210792 | SHEET<br>1 of 1 | REVISION<br>A1 |