

Am29C101

16-Bit CMOS Microprocessor Slice



Am29C101

Advanced Micro Devices

DISTINCTIVE CHARACTERISTICS

- Compatible to Am2901C**
 The Am29C101 is a low-power CMOS 16-bit version of the Am2901C, expandable to longer word lengths.
- Two-address architecture**
 Independent simultaneous access to two working registers saves machine cycles.
- Eight-function ALU**
 Performs addition, two subtraction operations, and five logic functions on two source operands.
- Expandable**
 Connect any number of Am29C101s together for longer word lengths.
- Left/right shift independent of ALU**
 Add and shift operations take only one cycle.
- Flexible data source selection**
 ALU data is selected from five source ports for a total of 203 source operand pairs for every ALU function.

GENERAL DESCRIPTION

The Am29C101 16-Bit CMOS Microprocessor Slice is a high-speed cascadable ALU intended for use in CPUs, peripheral controllers, and programmable microprocessors. The microinstruction flexibility of the Am29C101 permits efficient emulation of almost any digital computing machine.

The device, as shown in the block diagram, consists of a 16-word by 16-bit two-port RAM, a high-speed ALU, and the associated shifting, decoding and multiplexing circuitry.

The 9-bit microinstruction word is organized into three groups of 3 bits each and selects the ALU source operands, the ALU function, and the ALU destination register. The microprocessor is cascadable with full look ahead or with ripple carry, has three-state outputs, and provides various status-flag outputs from the ALU.

The Am29C101 is compatible with the Am2901C and is processed in low-power CMOS.

RELATED AMD PRODUCTS

Part No.	Description
Am27S35A	1024 x 8 Registered PROM
Am29C01	CMOS 4-Bit Microprocessor Slice
Am29C03	CMOS 4-Bit SUPERSLICE®
Am2904	Status and Shift Controller
Am29C10A	CMOS Microprogram Controller
Am29C111	CMOS 16-Bit Microsequencer
Am29C116	CMOS 16-Bit Microprocessor
Am29130	16-Bit Barrel Shifter
Am2914	Vectored Interrupt Controller
Am2918	Pipeline Register
Am2922	Condition Code MUX
Am2925	Clock Generator
Am29C331	CMOS 16-Bit Microprogram Sequencer
Am2940	DMA Address Generator
Am2952A	8-Bit Bidirectional I/O Port
Am29800A	High-Performance Bus Interface Family
Am29C800	High-Performance CMOS Bus Interface Family
Am29818	SSR™ Diagnostics/Pipeline Register

Orig *AMD*
 004785
 3 *1375*

BLOCK DIAGRAM

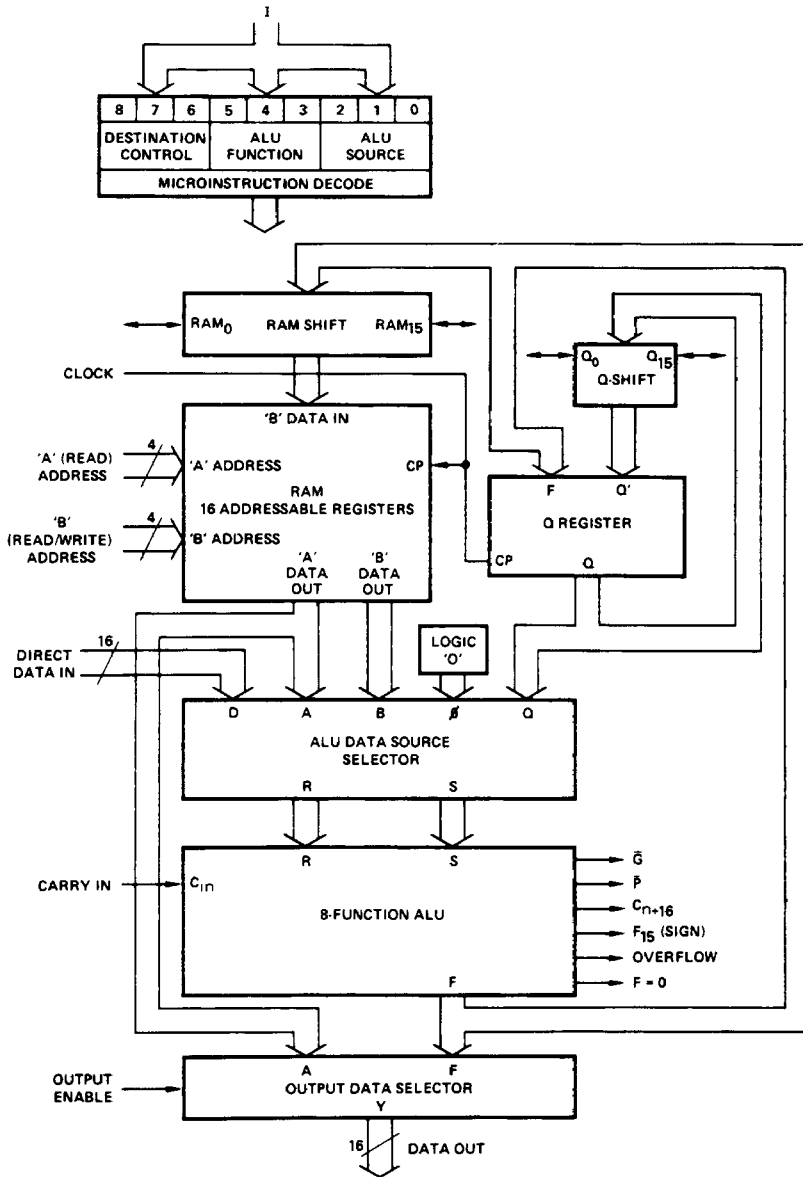

BD002124

For applications information see Chapters III and IV of
Bit Slice Microprocessor Design,
 by Mick and Brick, McGraw Hill Publishers.

CONNECTION DIAGRAMS Top View

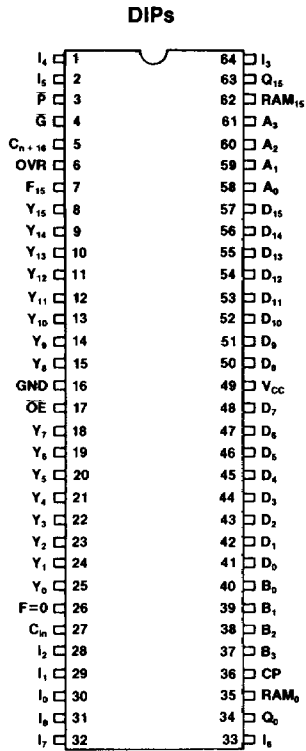

CD005943

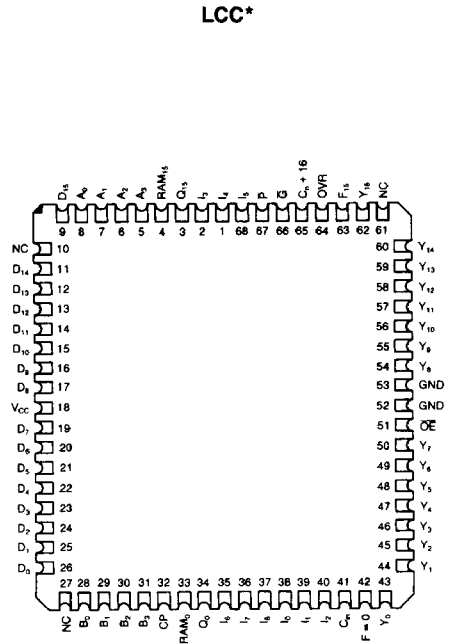

CD009340

Note: Pin 1 is marked for orientation.

* Also available in 68-Pin PLCC. Pinout is identical to LCC.

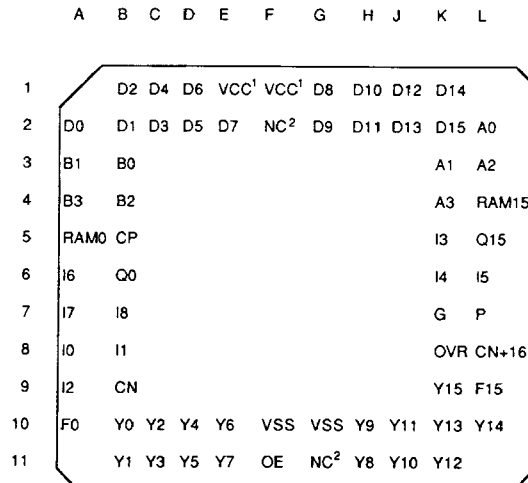

CD010740

- Notes: 1. Pins E1 and F1 are internally connected.
 2. NC = No Connection.
 3. Notch indicates orientation.

METALLIZATION AND PAD LAYOUT

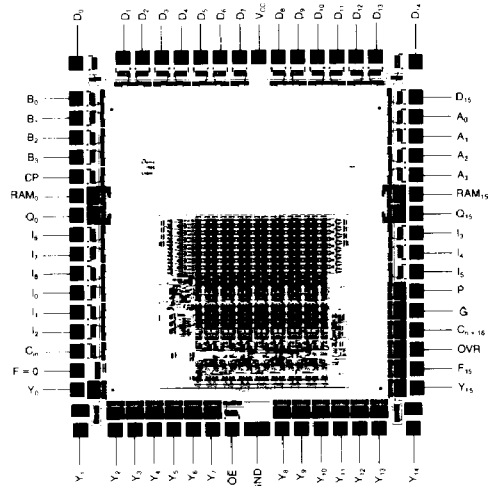

Die Size: 0.185" x 0.176"

Equivalent Gate Count: 2200 Gates

LOGIC SYMBOL

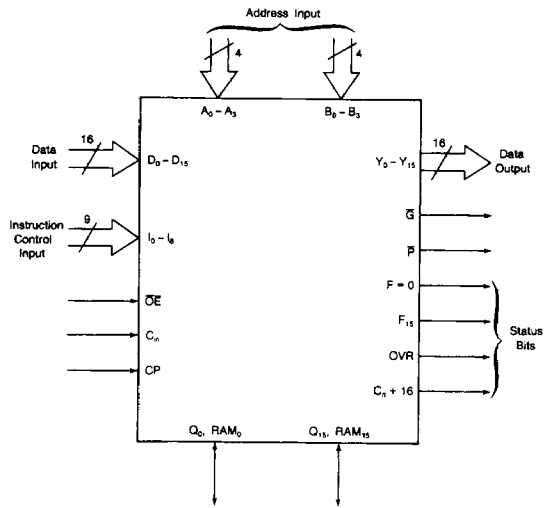

LS002310

V_{CC} = Power Supply

GND = Ground

ORDERING INFORMATION Standard Products

AMD standard products are available in several packages and operating ranges. The order number (Valid Combination) is formed by a combination of:

- a. Device Number**
- b. Speed Option** (if applicable)
- c. Package Type**
- d. Temperature Range**
- e. Optional Processing**

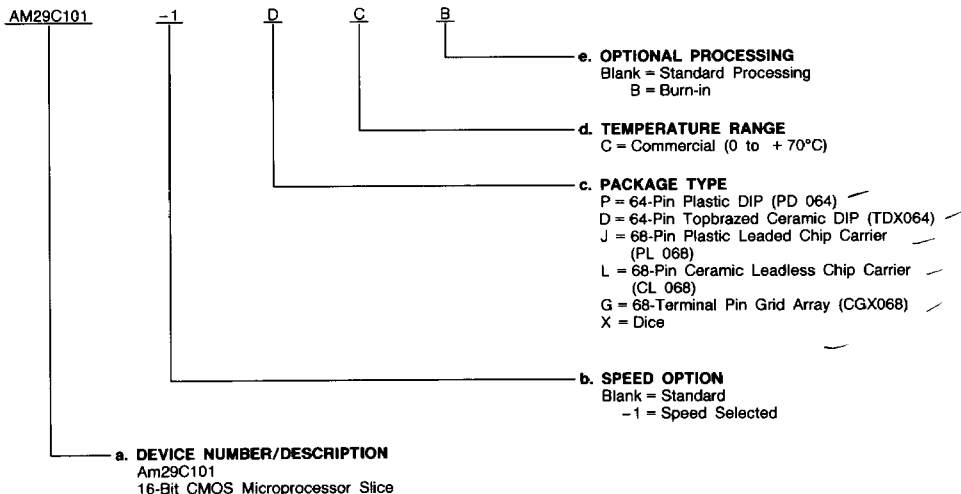

Valid Combinations	
AM29C101	PC, PCB, GC, DCB, JC, JCB, LC, GC, GCB, XC
AM29C101-1	PC, PCB, DC, DCB, JC, JCB, GC, GCB

Valid Combinations

Valid Combinations list configurations planned to be supported in volume for this device. Consult the local AMD sales office to confirm availability of specific valid combinations, to check on newly released combinations, and to obtain additional data on AMD's standard military grade products.

ORDERING INFORMATION (Cont'd.)

APL Products

AMD products for Aerospace and Defense applications are available in several packages and operating ranges. APL (Approved Products List) products are fully compliant with MIL-STD-883C requirements. The order number (Valid Combination) for APL products is formed by a combination of:

- a. **Device Number**
- b. **Speed Option** (if applicable)
- c. **Device Class**
- d. **Package Type**
- e. **Lead Finish**

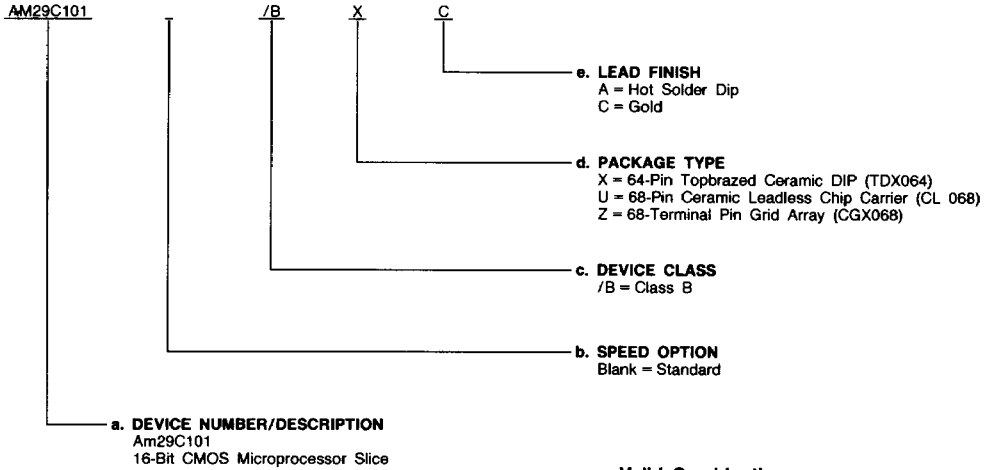

Valid Combinations	
AM29C101	/BXC, /BUA, /BZC

Valid Combinations

Valid Combinations list configurations planned to be supported in volume for this device. Consult the local AMD sales office to confirm availability of specific valid combinations or to check for newly released valid combinations.

Group A Tests

Group A tests consist of Subgroups 1, 2, 3, 7, 8, 9, 10, 11.

PIN DESCRIPTION

A₀ - A₃ Address Inputs — A Port (Input)

The four address inputs to the register stack used to select one register whose contents are displayed through the A Port.

B₀ - B₃ Address Inputs — B Port (Input)

The four address inputs to the register stack used to select one register whose contents are displayed through the B Port and into which new data can be written when the clock goes LOW.

C_{in} Carry In (Input)

The carry-in to the internal ALU.

C_n + 16 Carry Out (Output)

The carry-out of the internal ALU.

CP Clock (Input)

The Q-register and register-stack outputs change on the clock LOW-to-HIGH transition. The clock LOW time is internally the write enable pulse width to the 16 x 16 RAM. While the clock is LOW, the "slave" latches on the RAM outputs are closed, storing the data previously on the RAM outputs. This allows synchronous master-slave operation of the register stack.

D₀ - D₁₅ Direct Data Inputs (Input)

A 16-bit data field which may be selected as one of the ALU data sources for entering data into the device. D₀ is the LSB.

F = 0 Status Bit (Output, Open Drain)

This is an open-drain output which goes HIGH (OFF) if the data on the 16 ALU outputs (F₀ - F₁₅) are all LOW. In positive logic, it indicates the result of an ALU operation is zero.

F₁₅ Status Bit (Output)

The most significant ALU output bit.

\bar{G} , \bar{P} Carry Generate, Propagate Outputs (Output)

The carry generate and propagate outputs of the internal ALU. These signals are used with the Am2902 for carry-lookahead.

I₀ - I₈ Instruction Control Lines (Input)

The nine instruction control lines used to determine what data sources will be applied to the ALU (I₀₁₂), what function the ALU will perform (I₃₄₅), and what data is to be deposited in the Q register or the register stack (I₆₇₈).

$\bar{O}\bar{E}$ Output Enable (Input; Active LOW)

When $\bar{O}\bar{E}$ is HIGH, the Y outputs are OFF; when $\bar{O}\bar{E}$ is LOW, the Y outputs are active (HIGH or LOW).

OVR Overflow Status Bit (Output; Active HIGH)

This pin is logically the Exclusive-OR of the carry-in and carry-out of the MSB of the ALU. At the most significant end of the word, this pin indicates that the result of an arithmetic two's-complement operation has overflowed into the sign bit.

Q₀, RAM₀ Shift Lines (Input/Output)

Shift lines like Q₁₅ and RAM₁₅, but at the LSB of the Q register and RAM. These pins are tied to the Q₁₅ and RAM₁₅ pins of the adjacent device to transfer data between devices for up and down shifts of the Q register and ALU data.

Q₁₅, RAM₁₅ Shift Lines (Input/Output)

A shift line at the MSB of the Q register (Q₁₅) and the register stack (RAM₁₅). Electrically these lines are three-state outputs connected to TTL inputs internal to the device. When the destination code on I₆₇₈ indicates an up shift (octal 6 or 7), the three-state outputs are enabled and the MSB of the Q register is available on the Q₁₅ pin and the MSB of the ALU output is available on the RAM₁₅ pin. Otherwise, the three-state outputs are electrically OFF (high impedance) and the pins are electrically LS-TTL inputs. When the destination code calls for a down shift, the pins are used as the data inputs to the MSB of the Q register (octal 4) and RAM (octal 4 or 5).

Y₀ - Y₁₅ Data Outputs (Output, Three-State)

The 16 data outputs. These are three-state output lines. When enabled they display either the four outputs of the ALU or the data on the A Port of the register stack, as determined by the destination code I₆₇₈.

FUNCTIONAL DESCRIPTION

A detailed block diagram of the CMOS microprogrammable microprocessor structure is shown in Figure 1. The circuit is a 16-bit slice cascadable to any number of bits. Therefore, all 16 data paths within the circuit are 16 bits wide. The two key elements in the Figure 1 diagram are the 16-word by 16-bit 2-port RAM and the high-speed ALU.

Data in any of the 16 words of the Random-Access Memory (RAM) can be read from the A port of the RAM as controlled by the 4-bit A address field input. Likewise, data in any of the 16 words of the RAM as defined by the B address field input can be simultaneously read from the B port of the RAM. The same code can be applied to the A select field and B select field, in which case the identical file data will appear at both the RAM A port and B port outputs simultaneously.

When enabled by the RAM write enable (RAM EN), new data is always written into the file (word) defined by the B address field of the RAM. The RAM data input field is driven by a three-input multiplexer. This configuration is used to shift the ALU output data (F), if desired. This three-input multiplexer scheme allows the data to be shifted up one bit position, shifted down one bit position, or not shifted in either direction.

The RAM A port data outputs and RAM B port data outputs drive separate 16-bit latches. These latches hold the RAM data while the clock input is LOW. This eliminates any possible race conditions that could occur while new data is being written into the RAM.

The high-speed Arithmetic Logic Unit (ALU) can perform three binary arithmetic and five logic operations on the two 16-bit input words R and S. The R input field is driven from a two-input multiplexer, while the S input field is driven from a three-input multiplexer. Both multiplexers also have an inhibit capability; that is, no data is passed. This is equivalent to a "zero" source operand.

Referring to Figure 1, the ALU R input multiplexer has the RAM A port and the direct data inputs (D) connected as inputs. Likewise, the ALU S input multiplexer has the RAM A port, the RAM B port and the Q register connected as inputs.

This multiplexer scheme gives the capability of selecting various pairs of the A, B, D, Q, and "0" inputs as source operands to the ALU. These five inputs, when taken two at a time, result in ten possible combinations of source operand pairs. These combinations include AB, AD, AQ, A0, BD, BQ, B0, DQ, D0, and Q0. It is apparent that AD, AQ, and A0 are somewhat redundant with BD, BQ, and B0 in that if the A address and B address are the same, the identical function results. Thus, there are only seven completely non-redundant source operand pairs for the ALU. The Am29C101 microprocessor implements eight of these pairs. The microinstruction inputs used to select the ALU source operands are the I_0 , I_1 , and I_2 inputs. The definition of I_0 , I_1 , and I_2 for the eight source operand combinations are as shown in Table 1. Also shown is the octal code for each selection.

The two source operands not fully described as yet are the D input and Q input. The D input is the 16-bit wide direct data field input. This port is used to insert all data into the working registers inside the device. Likewise, this input can be used in the ALU to modify any of the internal data files. The Q register is a separate 16-bit file intended primarily for multiplication and division routines, but it can also be used as an accumulator or holding register for some applications.

The ALU itself is a high-speed arithmetic/logic operator capable of performing three binary arithmetic and five logic functions. The I_3 , I_4 , and I_5 microinstruction inputs are used to select the ALU function. The definition of these inputs is

shown in Table 2. The octal code is also shown for reference. The normal technique for cascading the ALU of several devices is in a look-ahead carry mode. Carry generate, \bar{G} , and carry propagate, \bar{P} , are outputs of the device for use with a carry-look-ahead-generator such as the Am2902A. A carry-out, C_{n+16} , is also generated and is available as an output for use as the carry flag in a status register. Both carry-in (C_n) and carry-out (C_{n+16}) are active HIGH.

The ALU has three other status-oriented outputs. These are F_{15} , $F = 0$, and overflow (OVR). The F_{15} output is the most significant (sign) bit of the ALU and can be used to determine positive or negative results without enabling the three-state data outputs. F_{15} is non-inverted with respect to the sign bit output Y_{15} . The $F = 0$ output is used for zero detect. It is an open-drain output and can be wire OR'ed between microprocessor slices. $F = 0$ is HIGH when all F outputs are LOW. The overflow output (OVR) is used to flag arithmetic operations that exceed the available two's complement number range. The overflow output (OVR) is HIGH when overflow exists. That is, when $C_n + 15$ and $C_n + 16$ are not the same polarity.

The ALU data output is routed to several destinations. It can be a data output of the device and it can also be stored in the RAM or the Q register. Eight possible combinations of ALU destination functions are available as defined by the I_6 , I_7 , and I_8 microinstruction inputs. These combinations are shown in Table 3.

The 16-bit data output field (Y) features three-state outputs and can be directly bus organized. An output control (\bar{OE}) is used to enable the three-state outputs. When \bar{OE} is HIGH, the Y outputs are in the high-impedance state.

A two-input multiplexer is also used at the data output such that either the A port of the RAM or the ALU outputs (F) are selected at the device Y outputs. This selection is controlled by the I_6 , I_7 , and I_8 microinstruction inputs. Refer to Table 3 for the selected output for each microinstruction code combination.

As was discussed previously, the RAM inputs are driven from a three-input multiplexer. This allows the ALU outputs to be entered non-shifted, shifted up one position ($\times 2$) or shifted down one position ($\div 2$). The shifter has two ports; one is labeled RAM_0 and the other is labeled RAM_{15} . Both of these ports consist of a buffer-driver with a three-state output and an input to the multiplexer. Thus, in the shift-up mode, the RAM_{15} buffer is enabled and the RAM_0 multiplexer input is enabled. Likewise, in the shift-down mode, the RAM_0 buffer and RAM_{15} input are enabled. In the no-shift mode, both buffers are in the high-impedance state and the multiplexer inputs are not selected. This shifter is controlled from the I_6 , I_7 , and I_8 microinstruction inputs as defined in Table 3.

Similarly, the Q register is driven from a three-input multiplexer. In the no-shift mode, the multiplexer enters the ALU data into the Q register. In either the shift-up or shift-down mode, the multiplexer selects the Q register data appropriately shifted up or down. The Q shifter also has two ports; one is labeled Q_0 and the other is Q_{15} . The operation of these two ports is similar to the RAM shifter and is also controlled from I_6 , I_7 , and I_8 as shown in Table 3.

The clock input to the Am29C101 controls the RAM, the Q register, and the A and B data latches. When enabled, data is clocked into the Q register on the LOW-to-HIGH transition of the clock. When the clock input is HIGH, the A and B latches are open and will pass whatever data is present at the RAM outputs. When the clock input is LOW, the latches are closed and will retain the last data entered. If the RAM-EN is enabled, new data will be written into the RAM file (word) defined by the B address field when the clock input is LOW.

FUNCTIONAL TABLES

TABLE 1. ALU SOURCE OPERAND CONTROL

Mnemonic	Micro Code				ALU Source Operands	
	I ₂	I ₁	I ₀	Octal Code	R	S
AQ	L	L	L	0	A	Q
AB	L	L	H	1	A	B
ZQ	L	H	L	2	0	Q
ZB	L	H	H	3	0	B
ZA	H	L	L	4	0	A
DA	H	L	H	5	D	A
DQ	H	H	L	6	D	Q
DZ	H	H	H	7	D	0

TABLE 2. ALU FUNCTION CONTROL

Mnemonic	Micro Code				ALU Function	Symbol
	I ₅	I ₄	I ₃	Octal Code		
ADD	L	L	L	0	R Plus S	R + S
SUBR	L	L	H	1	S Minus R	S - R
SUBS	L	H	L	2	R Minus S	R - S
OR	L	H	H	3	R OR S	R ∨ S
AND	H	L	L	4	R AND S	R ∧ S
NOTRS	H	L	H	5	R̄ AND S	R̄ ∧ S
EXOR	H	H	L	6	R EX-OR S	R ⊕ S
EXNOR	H	H	H	7	R EX-NOR S	R ⊘ S

TABLE 3. ALU DESTINATION CONTROL

Mnemonic	Micro Code				RAM Function		Q-Reg. Function		Y Output	RAM Shifter		Q Shifter	
	I ₈	I ₇	I ₆	Octal Code	Shift	Load	Shift	Load		RAM ₀	RAM ₁₅	Q ₀	Q ₁₅
QREG	L	L	L	0	X	NONE	NONE	F → Q	F	X	X	X	X
NOP	L	L	H	1	X	NONE	X	NONE	F	X	X	X	X
RAMA	L	H	L	2	NONE	F → B	X	NONE	A	X	X	X	X
RAMF	L	H	H	3	NONE	F → B	X	NONE	F	X	X	X	X
RAMQD	H	L	L	4	DOWN	F/2 → B	DOWN	Q/2 → Q	F	F ₀	IN ₁₅	Q ₀	IN ₁₅
RAMD	H	L	H	5	DOWN	F/2 → B	X	NONE	F	F ₀	IN ₁₅	Q ₀	X
RAMQU	H	H	L	6	UP	2F → B	UP	2Q → Q	F	IN ₀	F ₁₅	IN ₀	Q ₁₅
RAMU	H	H	H	7	UP	2F → B	X	NONE	F	IN ₀	F ₁₅	X	Q ₁₅

X = Don't care. Electrically, the shift pin is a TTL-equivalent input internally connected to a three-state output which is in the high-impedance state.
 B = Register Addressed by B inputs.
 UP is toward MSB, DOWN is toward LSB.

TABLE 4. SOURCE OPERAND and ALU FUNCTION MATRIX

Octal I ₅₄₃	ALU Function	I ₂₁₀ Octal							
		0	1	2	3	4	5	6	7
		ALU Source							
		A, Q	A, B	0, Q	0, B	0, A	D, A	D, Q	D, 0
0	C _n = L	A + Q	A + B	Q	B	A	D + A	D + Q	D
	R Plus S C _n = H	A + Q + 1	A + B + 1	Q + 1	B + 1	A + 1	D + A + 1	D + Q + 1	D + 1
1	C _n = L	Q - A - 1	B - A - 1	Q - 1	B - 1	A - 1	A - D - 1	Q - D - 1	-D - 1
	S Minus R C _n = H	Q - A	B - A	Q	B	A	A - D	Q - D	-D
2	C _n = L	A - Q - 1	A - B - 1	-Q - 1	-B - 1	-A - 1	D - A - 1	D - Q - 1	D - 1
	R Minus S C _n = H	A - Q	A - B	-Q	-B	-A	D - A	D - Q	D
3	R OR S	A ∨ Q	A ∨ B	Q	B	A	D ∨ A	D ∨ Q	D
4	R AND S	A ∧ Q	A ∧ B	0	0	0	D ∧ A	D ∧ Q	0
5	R̄ AND S	Ā ∧ Q	Ā ∧ B	Q	B	A	D̄ ∧ A	D̄ ∧ Q	0
6	R EX-OR S	A ⊕ Q	A ⊕ B	Q	B	A	D ⊕ A	D ⊕ Q	D
7	R EX-NOR S	Ā ⊕ Q	Ā ⊕ B	Q̄	B̄	Ā	D̄ ⊕ A	D̄ ⊕ Q	D̄

+ = Plus
 - = Minus
 ∨ = OR
 ∧ = AND
 ⊕ = EX-OR

TABLE 5. ALU LOGIC MODE FUNCTIONS

Octal I ₅₄₃ , I ₂₁₀	Group	Function
4 0 4 1 4 5 4 6	AND	A \wedge Q A \wedge B D \wedge A D \wedge Q
3 0 3 1 3 5 3 6	OR	A \vee Q A \vee B D \vee A D \vee Q
6 0 6 1 6 5 6 6	EX-OR	A ∇ Q A ∇ B D ∇ A D ∇ Q
7 0 7 1 7 5 7 6	EX-NOR	$\overline{A \nabla Q}$ $\overline{A \nabla B}$ $\overline{D \nabla A}$ $\overline{D \nabla Q}$
7 2 7 3 7 4 7 7	INVERT	\overline{Q} \overline{B} \overline{A} \overline{D}
6 2 6 3 6 4 6 7	PASS	Q B A D
3 2 3 3 3 4 3 7	PASS	Q B A D
4 2 4 3 4 4 4 7	"ZERO"	0 0 0 0
5 0 5 1 5 5 5 6	MASK	$\overline{A} \wedge Q$ $\overline{A} \wedge B$ $\overline{D} \wedge A$ $\overline{D} \wedge Q$

TABLE 6. ALU ARITHMETIC MODE FUNCTIONS

Octal I ₅₄₃ , I ₂₁₀	C _{in} = L		C _{in} = H	
	Group	Function	Group	Function
0 0 0 1 0 5 0 6	ADD	A + Q A + B D + A D + Q	ADD plus one	A + Q + 1 A + B + 1 D + A + 1 D + Q + 1
0 2 0 3 0 4 0 7	PASS	Q B A D	Increment	Q + 1 B + 1 A + 1 D + 1
1 2 1 3 1 4 2 7	Decrement	Q - 1 B - 1 A - 1 D - 1	PASS	Q B A D
2 2 2 3 2 4 1 7	1's Comp.	-Q - 1 -B - 1 -A - 1 -D - 1	2's Comp. (Negate)	-Q -B -A -D
1 0 1 1 1 5 1 6 2 0 2 1 2 5 2 6	Subtract (1's Comp)	Q - A - 1 B - A - 1 A - D - 1 Q - D - 1 A - Q - 1 A - B - 1 D - A - 1 D - Q - 1	Subtract (2's Comp)	Q - A B - A A - D Q - D A - Q A - B D - A D - Q

Source Operands and ALU Functions

There are eight source operand pairs available to the ALU as selected by the I₀, I₁, and I₂ instruction inputs. The ALU can perform eight functions; five logic and three arithmetic. The I₃, I₄, and I₅ instruction inputs control this function selection. The carry input, C_{in}, also affects the ALU results when in the arithmetic mode. The C_{in} input has no effect in the logic mode. When I₀ through I₅ and C_{in} are viewed together, the matrix of Table 4 results. This matrix fully defines the ALU/source operand function for each state.

The ALU functions can also be examined on a "task" basis, i.e., add, subtract, AND, OR, etc. In the arithmetic mode, the carry will affect the function performed, while in the logic mode

the carry will have no bearing on the ALU output. Table 5 defines the various logic operations that the Am29C101 can perform, and Table 6 shows the arithmetic functions of the device. Both carry-in LOW (C_{in} = 0) and carry-in HIGH (C_{in} = 1) are defined in these operations.

Logic Functions for \overline{G} , \overline{P} , C_n + 16, and OVR

The four signals \overline{G} , \overline{P} , C_n + 16, and OVR are designed to indicate carry and overflow conditions when the Am29C101 is in the add or subtract mode. Table 7 indicates the logic equations for these four signals for each of the eight ALU functions. In a logical operation, \overline{P} and \overline{G} are always HIGH; OVR and C_n + 16 are LOW. The R and S inputs are the two inputs selected according to Table 1.

TABLE 7. LOGIC FUNCTIONS for CARRY and OVERFLOW CONDITIONS

I ₅₄₃	Function	\bar{P}	\bar{G}	$C_n + 16$	OVR
0	R + S	$\overline{P_{0-15}}$	$\overline{G_{15} + P_{15} G_{14} + P_{15} P_{14} G_{13} + \dots + P_{1-15} G_0}$	C_{16}	$C_{16} \nabla C_{15}$
1	S - R	← Same as R + S equations, but substitute \bar{R}_i for R_i in definitions →			
2	R - S	← Same as R + S equations, but substitute \bar{S}_i for S_i in definitions →			
3	R v S	HIGH	HIGH	LOW	LOW
4	R ^ S	HIGH	HIGH	LOW	LOW
5	$\bar{R} \wedge S$	HIGH	HIGH	LOW	LOW
6	R ∇ S	HIGH	HIGH	LOW	LOW
7	$\bar{R} \nabla \bar{S}$	HIGH	HIGH	LOW	LOW

Definitions: + = OR

$P_0 = R_0 + S_0$

$P_1 = R_1 + S_1$

$P_2 = R_2 + S_2$

$P_3 = R_3 + S_3$, etc.

$G_0 = R_0 S_0$

$G_1 = R_1 S_1$

$G_2 = R_2 S_2$

$G_3 = R_3 S_3$, etc.

$C_{16} = G_{15} + P_{15} G_{14} + P_{15} P_{14} G_{13} + \dots + P_{0-15} C_n$

$C_{15} = G_{14} + P_{14} G_{13} + P_{14} P_{13} G_{12} + \dots + P_{0-14} C_n$

APPLICATIONS

Minimum Cycle Time Calculations for 16-Bit Systems

Speeds used in calculations for parts other than Am29C101 and Am29C10A are representative for available MSI parts.

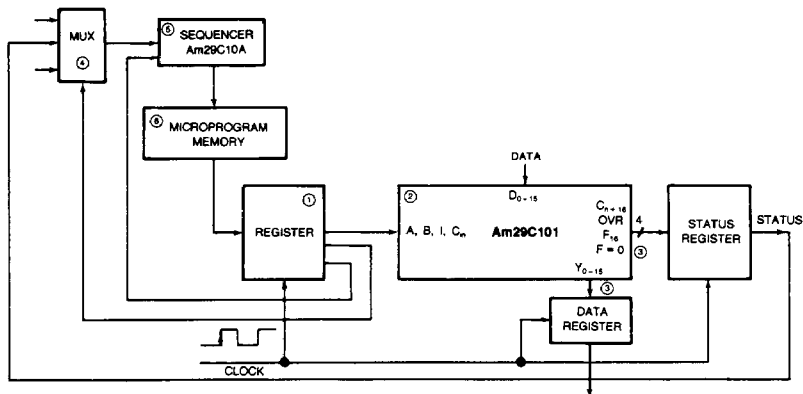

BD005292

Am29C101 DATA LOOP

① Register	Clock to Output	11 ns
+ ② 29C101	A, B to Y, $C_n + 16$, OVR	37 ns
+ ③ Register	Setup Time	4 ns
		<u>52 ns</u>

CONTROL LOOP

① Register	Clock to Output	11 ns
+ ④ MUX	Select to Output	13 ns
+ ⑤ 29C10A-1	CC to Output	26 ns
+ ⑥ PROM	Access Time	30 ns
+ ⑦ Register	Setup Time	4 ns
		<u>84 ns</u>

Minimum clock period = 88 ns

For Reference:

Am2901B/C DATA LOOP		Am2901C	Am2901B
① Register	Clock to Output	11 ns	11 ns
+ ② 2901	A, B to \bar{G} , \bar{P}	37 ns	50 ns
+ ③ 2902A	G_0 , P_0 to $C_n + z$	7 ns	7 ns
+ ④ 2901	C_n to $C_n + 4$, OVR, F_3 , $F = 0$, Y	25 ns	37 ns
+ ⑤ Register	Setup Time	4 ns	4 ns
		<u>84 ns</u>	<u>109 ns</u>

Figure 2. Pipelined System, Add Without Simultaneous Shift

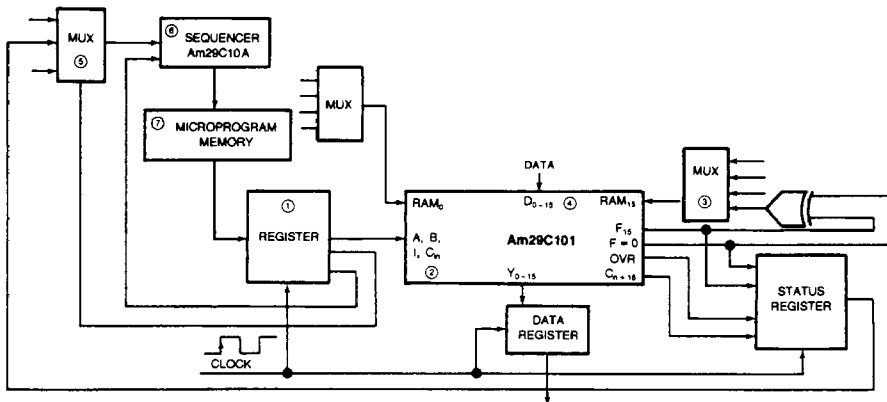

BD005282

Am29C101 DATA LOOP

① Register	Clock to Output	11 ns
+ ② 29C101-1	A, B to F = 0, OVR, F ₁₅	40 ns
+ ③ XOR and MUX		21 ns
+ ④ 29C101-1	RAM ₁₅ Setup	12 ns
		<hr/> 82 ns

CONTROL LOOP

① Register	Clock to Output	11 ns
+ ⑤ MUX	Select to Output	13 ns
+ ⑥ 29C10A	CC to Output	26 ns
+ ⑦ PROM	Access Time	30 ns
+ ① Register	Setup Time	4 ns
		<hr/> 84 ns

Minimum clock period = 90 ns

For Reference:

Am2901B/C DATA LOOP		Am2901C	Am2901B
① Register	Clock to Output	11 ns	11 ns
+ ② 2901	A, B to \bar{G} , \bar{P}	37 ns	50 ns
+ ③ 2902A	\bar{G}_0, \bar{P}_0 to C _n + z	7 ns	7 ns
+ ④ 2901	C _n to F ₃ , OVR	22 ns	29 ns
+ ⑤ XOR & MUX		21 ns	21 ns
+ ⑥ 2901	RAM ₃ Setup	12 ns	16 ns
		<hr/> 110 ns	<hr/> 134 ns

Figure 3. Pipelined System, Simultaneous Add and Shift Down

ABSOLUTE MAXIMUM RATINGS

Storage Temperature	-65 to +150°C
Ambient Temperature Under Bias	-55 to +125°C
Supply Voltage to Ground Potential	
Continuous	-0.3 to +7.0 V
DC Voltage Applied to Outputs For	
High Output State	-0.3 to +V _{CC} + 0.3 V
DC Input Voltage	-0.3 to +V _{CC} + 0.3 V
DC Output Current, Into LOW Outputs	30 mA
DC Input Current	-10 to +10 mA

Stresses above those listed under ABSOLUTE MAXIMUM RATINGS may cause permanent device failure. Functionality at or above these limits is not implied. Exposure to absolute maximum ratings for extended periods may affect device reliability.

OPERATING RANGES

Commercial (C) Devices	
Ambient Temperature (T _A)	0° to +70°C
Supply Voltage (V _{CC})	+4.5 V to +5.5 V
Military* (M) Devices	
Case Temperature (T _A)	-55 to +125°C
Supply Voltage (V _{CC})	+4.5 to +5.5 V

Operating ranges define those limits between which the functionality of the device is guaranteed.

*Military Product 100% tested at T_A = +25°C, +125°C, and -55°C.

DC CHARACTERISTICS over operating ranges unless otherwise specified; Included in Group A, Subgroup 1, 2, 3 tests unless otherwise noted.

Parameter Symbol	Parameter Description	Test Conditions (Note 1)		Min.	Max.	Units
V _{OH}	Output HIGH Voltage	V _{CC} = Min. V _{IN} = V _{IH} or V _{IL}	I _{OH} = -1.6 mA All Others	2.4		V
			I _{OH} = -600 μA RAM ₀ , RAM ₁₅ , Q ₀ , Q ₁₅	2.4		
I _{CEX}	Output Leakage Current For F = 0 Output	V _{CC} = Min., V _{OH} = 5.5 V V _{IN} = V _{IH} or V _{IL}			10	μA
V _{OL}	Output LOW Voltage	V _{CC} = Min., V _{IN} = V _{IH} or V _{IL}	All Others I _{OL} = 20 mA		0.5	V
			I _{OL} = 6.0 mA		0.5	
V _{IH}	Input HIGH Level	Guaranteed Input Logical HIGH Voltage for All Inputs (Note 2)		2.0		V
V _{IL}	Input LOW Level	Guaranteed Input Logical LOW Voltage for All Inputs (Note 2)			0.8	V
I _{IL}	Input LOW Current	V _{CC} = Max., V _{IN} = 0.5 V			-10	μA
I _{IH}	Input HIGH Current	V _{CC} = Max., V _{IN} = V _{CC} - 0.5 V			10	μA
I _{OZH} I _{OZL}	Off State (High Impedance) Output Current	V _{CC} = Max.	Y ₀₋₁₅	V _O = 2.4 V	10	μA
				V _O = 0.5 V	-10	
I _{CC}	Static Power Supply Current	V _{CC} = Max., V _{IN} = V _{CC} or GND, I _O = 0 μA	T _A = 0° to +70°C (COM'L only)		40	mA
			T _A = -55° to +125°C (MIL only)		55	
C _{PD}	Power Dissipation Capacitance (Note 3)	V _{CC} = 5.0 V, T _A = 25°C, No Load		1300 pF Typical		

Notes:

- For conditions shown as Min. or Max., use the appropriate value under Operating Ranges for the applicable device type.
- These input levels provide zero noise immunity and should only be statically tested in a noise-free environment (not functionally tested).
- C_{PD} determines the no-load dynamic current consumption:
I_{CC} (Total) = I_{CC} (Static) + C_{PD} V_{CC} f, where f is the switching frequency of the majority of the internal nodes, normally one-half of the clock frequency.

SWITCHING CHARACTERISTICS over Commercial Operating Range unless otherwise specified.

Am29C101

The following tables specify the guaranteed performance of the Am29C101 over the commercial operating range of 0°C to +70°C, with V_{CC} from 4.5 V to 5.5 V. All data are in ns, with measurements made at 1.5 V. All outputs have maximum DC load, C_L = 50 pF.

A. Cycle Time and Clock Characteristics

Read-Modify-Write Cycle (from selection of A, B registers to end of cycle.)	35 ns*
Maximum Clock Frequency to shift Q (50% duty cycle, I = 432 or 632)	25 MHz*
Minimum Clock LOW Time	20 ns
Minimum Clock HIGH Time	20 ns
Minimum Clock Period	40 ns*

*These specs are not tested, but are derived from other specs.

B. Combinational Propagation Delays (Note 1)

From Input	To Output							
	Y	F ₁₅	C _{n+16}	\bar{G}, \bar{P}	F = 0	OVR	RAM ₀ RAM ₁₅	Q ₀ Q ₁₅
A, B Address	46	43	35	37	(49)	41	42	-
D	38	35	27	27	40	34	36	-
C _{in}	28	24	16	-	28	23	25	-
I012	43	40	33	30	46	33	36	-
I345	41	38	32	28	45	36	39	-
I678	20	-	-	-	-	-	29	29
A Bypass ALU (I = 2XX)	23	-	-	-	-	-	-	-
Clock 	38	34	25	27	36	32	34	17

C. Setup and Hold Times Relative to Clock (CP) Input (Note 1)

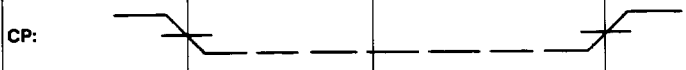
Input	CP: 			
	Setup Time Before H → L	Hold Time After H → L	Setup Time Before L → H	Hold Time After L → H
A, B Source Address	12	3 (Note 3)	40, (20 + T _{PWL}) (Note 4)	-
B Destination Address	12	Do Not Change (Note 2)		0
D	-	-	26	0
C _{in}	-	-	16	0
I012	-	-	30	0
I345	-	-	31	0
I678	10	Do Not Change (Note 2)		0
RAM _{0, 15} , Q _{0, 15}	-	-	12	0

D. Output Enable/Disable Times (Note 6)

Input	Output	Enable	Disable
\bar{OE}	Y	25	16

Notes: See Switching Characteristics Notes following Am29C101 Military Switching Characteristics tables.

SWITCHING CHARACTERISTICS Over Commercial Operating Range (Cont'd.)

Am29C101-1

The following tables specify the guaranteed performance of the Am29C101 over the commercial operating range of 0°C to +70°C, with V_{CC} from 4.5 V to 5.5 V. All data are in ns, with measurements made at 1.5 V. All outputs have maximum DC load, $C_L = 50$ pF.

A. Cycle Time and Clock Characteristics

Read-Modify-Write Cycle (from selection of A, B registers to end of cycle.)	30 ns*
Maximum Clock Frequency to shift Q (50% duty cycle, I = 432 or 632)	33 MHz*
Minimum Clock LOW Time	15 ns
Minimum Clock HIGH Time	15 ns
Minimum Clock Period	30 ns*

*These specs are not tested, but are derived from other specs.

B. Combinational Propagation Delays (Note 1)

From Input	To Output							
	Y	F ₁₅	C _{n + 16}	\bar{Q} , \bar{P}	F = 0	OVR	RAM ₀ RAM ₁₅	Q ₀ Q ₁₅
A, B Address	37	35	27	26	40	33	35	-
D	30	28	22	20	32	26	23	-
C _{in}	22	20	10	-	24	18	20	-
I012	35	32	26	21	36	26	25	-
I345	33	30	25	23	35	30	27	-
I678	15	-	-	-	-	-	20	20
A Bypass ALU (I = 2XX)	18	-	-	-	-	-	-	-
Clock \square	31	26	21	21	31	25	26	14

C. Setup and Hold Times Relative to Clock (CP) Input (Note 1)

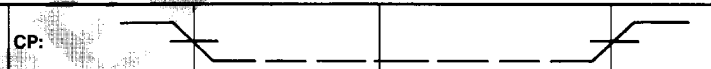
Input	CP: 			
	Setup Time Before H -L	Hold Time After H -L	Setup Time Before L -H	Hold Time After L -H
A, B Source Address	10	3 (Note 3)	30, (15 + T _{PWL}) (Note 4)	-
B Destination Address	10	Do Not Change (Note 2)		0
D	-	-	22	0
C _{in}	-	-	13	0
I012	-	-	25	0
I345	-	-	26	0
I678	7	Do Not Change (Note 2)		0
RAM _{0, 15} , Q _{0, 15}	-	-	10	0

D. Output Enable/Disable Times (Note 6)

Input	Output	Enable	Disable
\bar{OE}	Y	20	15

Notes: See Switching Characteristics Notes following Am29C101 Military Switching Characteristics tables.

SWITCHING CHARACTERISTICS over Military Operating Range unless otherwise specified; Included in Group A, Subgroup 9, 10, 11 tests unless otherwise noted.

Am29C101

A. Cycle Time and Clock Characteristics

The following tables specify the guaranteed performance of the Am29C101 over the military operating range of -55°C to $+125^{\circ}\text{C}$, with V_{CC} from 4.5 V to 5.5 V. All data are in ns, with measurements made at 1.5 V. All outputs have maximum DC load, $C_L = 50$ pF

Read-Modify-Write Cycle (from selection of A, B registers to end of cycle.)	45 ns*
Maximum Clock Frequency to shift Q (50% duty cycle, I = 432 or 632)	25 MHz*
Minimum Clock LOW Time	20 ns
Minimum Clock HIGH Time	20 ns
Minimum Clock Period	45 ns*

*These specs are not tested, but are derived from other specs.

B. Combinational Propagation Delays (Note 1)

From Input	To Output							
	Y	F ₁₅	C _{n+16}	\bar{G}, \bar{P}	F = 0	OVR	RAM ₀ RAM ₁₅	Q ₀ Q ₁₅
A, B Address	52	50	40	38	56	46	50	-
D	44	40	30	32	46	39	41	-
C _{in}	33	28	15	-	33	27	30	-
I012	50	47	36	34	53	38	41	-
I345	47	44	35	35	51	44	45	-
I678	22	-	-	-	-	-	30	30
A Bypass ALU (I = 2XX)	27	-	-	-	-	-	-	-
Clock 	44	39	30	32	42	36	30	21

C. Setup and Hold Times Relative to Clock (CP) Input (Note 1)

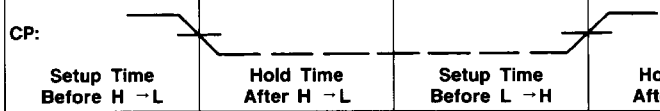
Input				
	Setup Time Before H → L	Hold Time After H → L	Setup Time Before L → H	Hold Time After L → H
A, B Source Address	17	3 (Note 3)	40, (20 + TPWL) (Note 4)	-
B Destination Address	17	Do Not Change (Note 2)		0
D	-	-	33	0
C _{in}	-	-	20	0
I012	-	-	37	0
I345	-	-	36	0
I678	10	Do Not Change (Note 2)		0
RAM _{0, 15} , Q _{0, 15}	-	-	12	2

D. Output Enable/Disable Times (Note 6)

Input	Output	Enable	Disable
\bar{OE}	Y	28	20

Notes: See Switching Characteristics Notes following Am29C101 Military Switching Characteristics tables.

Switching Characteristics Notes:

1. A dash indicates a propagation delay path or setup time constraint does not exist.
2. Certain signals must be stable during the entire clock LOW time to avoid erroneous operation. This is indicated by the phrase "do not change."
3. Source addresses must be stable prior to the clock H→L transition to allow time to access the source data before the latches close. The A address may then be changed. The B address could be changed if it is not a destination; i.e., if data is not being written back into the RAM. **Normally A and B are not changed during the clock LOW time.**
4. The setup time prior to the clock L→H transition is to allow time for data to be accessed, passed through the ALU, and returned to the RAM. It includes all the time from stable A and B addresses to the clock L→H transition, regardless of when the clock H→L transition occurs.
5. \overline{G} and \overline{P} are held HIGH, and OVR and $C_n + 16$ are held LOW during an ALU logic operation.
6. Output disable times are specified with $C_L = 5$ pF and measured to 0.5 V change of output-voltage level. Enable times are specified with $C_L = 50$ pF and measured at 1.5 V output-voltage level.

SWITCHING TEST CIRCUITS

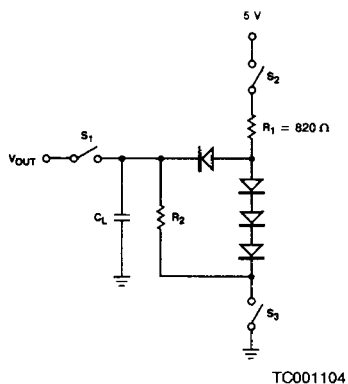

$$R_1 = \frac{5.0 - V_{BE} - V_{OL}}{I_{OL} + V_{OL}/1R_2}$$

A. Three-State Outputs

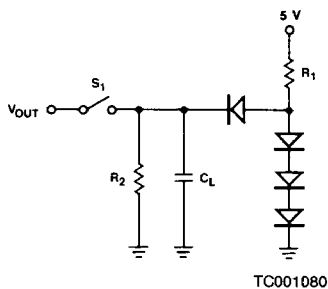

$$R_2 = \frac{2.4 \text{ V}}{I_{OH}}$$

$$R_1 = \frac{5.0 - V_{BE} - V_{OL}}{I_{OL} + V_{OL}/R_2}$$

B. Normal Outputs

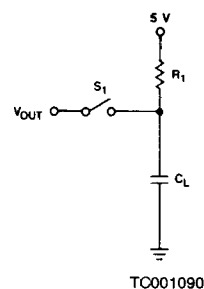

$$R_1 = \frac{5.0 - V_{OL}}{I_{OL}}$$

C. Open-Drain Outputs

TEST OUTPUT LOADS		
Output Pin Name	R ₁ (Ω)	R ₂ (Ω)
Y ₀ - Y ₁₅ (Three State)	220	1K
C _n + 16, C _{in} , F ₁₅ , \overline{G} , \overline{P} , OVR	220	1K
F = 0 (Open Drain)	270	-
RAM ₀ , RAM ₁₅ Q ₀ , Q ₁₅	560	1K

- Notes:
1. $C_L = 50$ pF includes scope probe, wiring and stray capacitances without device in test fixture.
 2. S₁, S₂, S₃ are closed during function tests and all AC tests except output enable tests.
 3. S₁ and S₃ are closed while S₂ is open for t_{pZH} test.
S₁ and S₂ are closed while S₃ is open for t_{pZL} test.
 4. $C_L = 5.0$ pF for output disable tests.

SWITCHING TEST WAVEFORMS

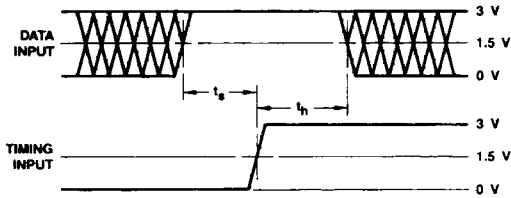

WFR02970

- Notes: 1. Diagram shown for HIGH data only.
Output transition may be opposite sense.
2. Cross hatched area is don't care condition.

Setup, Hold, and Release Times

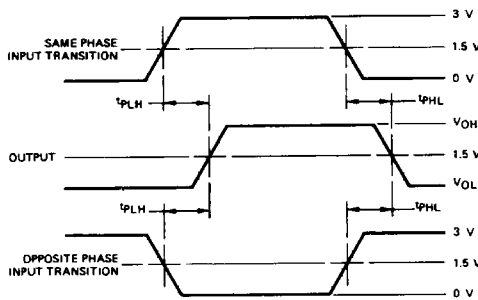

WFR02980

Propagation Delay

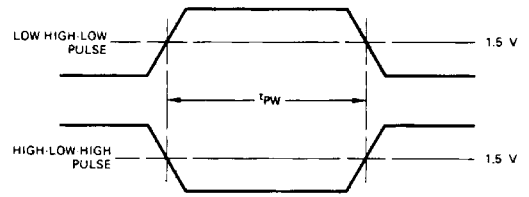

WFR02790

Pulse Width

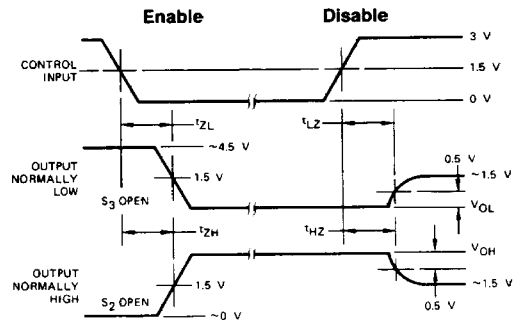

WFR02660

- Notes: 1. Diagram shown for Input Control Enable-LOW and Input Control Disable-HIGH.
2. S_1 , S_2 and S_3 of Load Circuit are closed except where shown.

Enable and Disable Times

Notes on Test Methods

The following points give the general philosophy that we apply to tests that must be properly engineered if they are to be implemented in an automatic environment. The specifics of what philosophies applied to which test are shown in the data sheet.

1. Ensure the part is adequately decoupled at the test head. Large changes in V_{CC} current as the device switches may cause erroneous function failures due to V_{CC} changes.
2. Do not leave inputs floating during any tests, as they may start to oscillate at high frequency.
3. Do not attempt to perform threshold tests at high speed. Following an output transition, ground current may change by as much as 400 mA in 5-8 ns. Inductance in the ground cable may allow the ground pin at the device to rise by hundreds of millivolts momentarily.
4. Use extreme care in defining input levels for AC tests. Many inputs may be changed at once, so there will be significant noise at the device pins and they may not actually reach V_{IL} or V_{IH} until the noise has settled. AMD recommends using $V_{IL} \leq 0$ V and $V_{IH} \geq 3.0$ V for AC tests.
5. To simplify failure analysis, programs should be designed to perform DC, Function, and AC tests as three distinct groups of tests.
6. Capacitive Loading for AC Testing
Automatic testers and their associated hardware have stray capacitance that varies from one type of tester to another but is generally around 50 pF. This, of course, makes it impossible to make direct measurements of parameters that call for smaller capacitive load than the associated stray capacitance. Typical examples of this are the so-called "float delays" which measure the propagation delays into the high-impedance state and are usually specified at a load capacitance of 5.0 pF. In these cases, the test is performed at the higher load capacitance (typically 50 pF) and engineering correlations based on data taken with a bench setup are used to predict the result at the lower capacitance.
Similarly, a product may be specified at more than one capacitive load. Since the typical automatic tester is not capable of switching loads in mid-test, it is impossible to make measurements at both capacitances even though they may both be greater than the stray capacitance. In these cases, a measurement is made at one of the two capacitances. The result at the other capacitance is predict-

ed from engineering correlations based on data taken with a bench set up and the knowledge that certain DC measurements (I_{QH} , I_{QL} , for example) have already been taken and are within spec. In some cases, special DC tests are performed in order to facilitate this correlation.

7. Threshold Testing

The noise associated with automatic testing (due to the long, inductive cables) and the high gain of the tested device when in the vicinity of the actual device threshold, frequently give rise to oscillations when testing high-speed circuits. These oscillations are not indicative of a reject device, but instead, of an overtaxed test system. To minimize this problem, thresholds are tested at least once for each input pin. Thereafter, "hard" high and low levels are used for other tests. Generally this means that function and A.C. testing are performed at "hard" input levels rather than at V_{IL} Max. and V_{IH} Min.

8. AC Testing

Occasionally, parameters are specified that cannot be measured directly on automatic testers because of tester limitations. Data input hold times often fall into this category. In these cases, the parameter in question is guaranteed by correlating these tests with other AC tests that have been performed. These correlations are arrived at by the cognizant engineer by using data from precise bench measurements in conjunction with the knowledge that certain DC parameters have already been measured and are within spec.

In some cases, certain AC tests are redundant since they can be shown to be predicted by other tests that have already been performed. In these cases, the redundant tests are not performed.

INPUT/OUTPUT CIRCUIT DIAGRAMS*

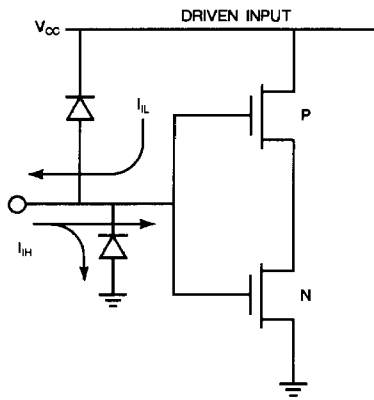

IC000863

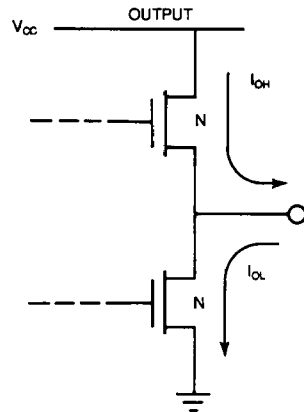

IC000870

* $C_1 \approx 5.0$ pF, all inputs (Plastic Pkg.)
 $C_1 \approx 10.0$ pF, all inputs (Ceramic Pkg.)

PHYSICAL DIMENSIONS*

TDX064

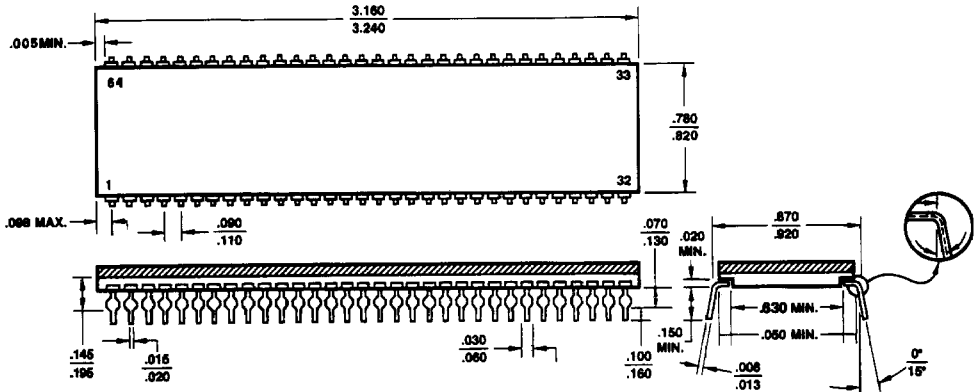

PID # 06366B

PD 064

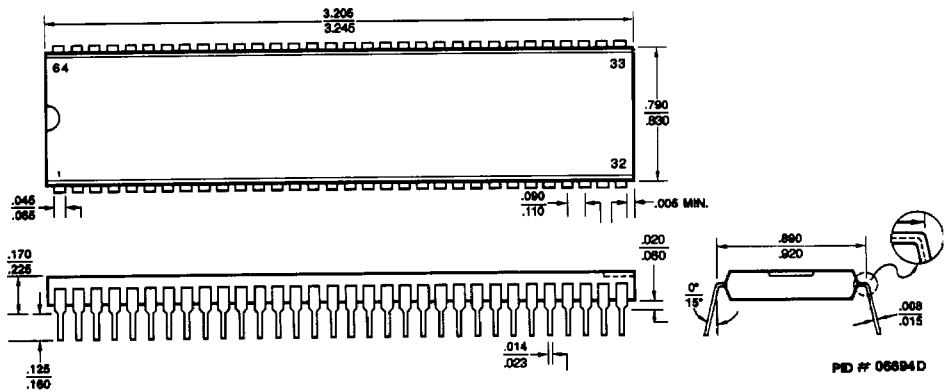

PID # 06694D

*For reference only.

PHYSICAL DIMENSIONS (Cont'd.)

PL 068

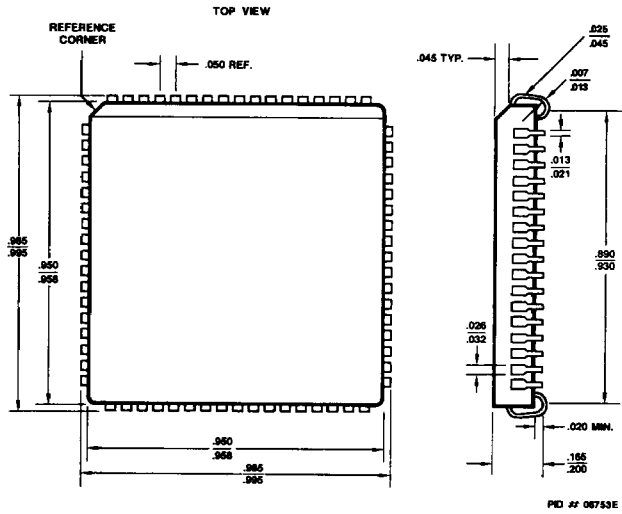

CL 068

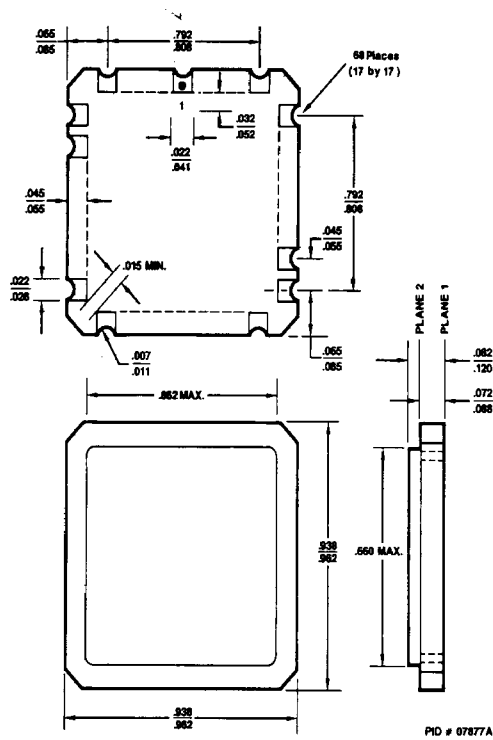

PHYSICAL DIMENSIONS (Cont'd.)

#136

CGX068

BOTTOM VIEW

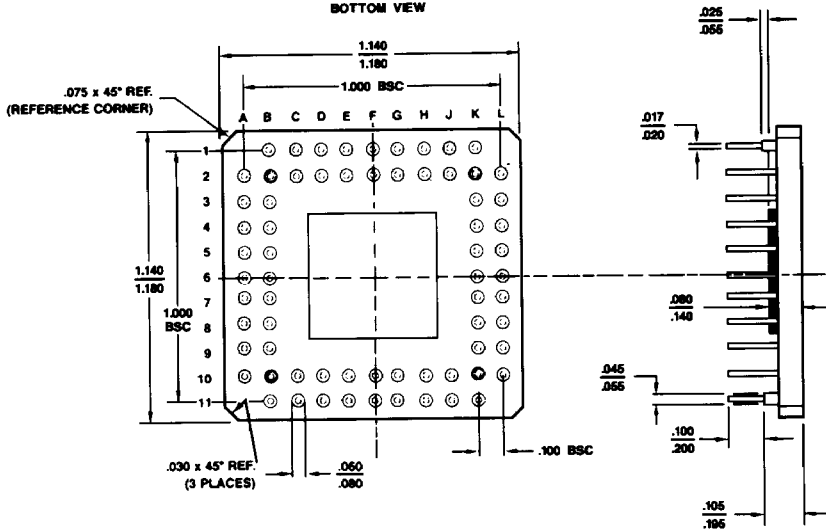

PD # 07547B

ADVANCED MICRO DEVICES DOMESTIC SALES OFFICES

ALABAMA	(205) 882-9122	MASSACHUSETTS	(617) 273-3970
ARIZONA,		MINNESOTA	(612) 938-0001
Tempe	(602) 242-4400	MISSOURI	(314) 275-4415
CALIFORNIA,		NEW JERSEY	(201) 299-0002
Culver City	(213) 645-1524	NEW YORK,	
Newport Beach	(714) 752-6262	Liverpool	(315) 457-5400
San Diego	(619) 560-7030	Poughkeepsie	(914) 471-8180
Sunnyvale	(408) 720-8811	Woodbury	(516) 364-8020
Woodland Hills	(818) 992-4155	NORTH CAROLINA,	
COLORADO	(303) 741-2900	OREGON	(503) 245-0080
CONNECTICUT	(203) 264-7800	OHIO	(614) 891-6455
FLORIDA,		PENNSYLVANIA,	
Clearwater	(813) 530-9971	Allentown	(215) 398-8006
Ft. Lauderdale	(305) 484-8600	Willow Grove	(215) 657-3101
Melbourne	(305) 729-0496	TEXAS,	
Orlando	(305) 859-0831	Austin	(512) 346-7830
GEORGIA	(404) 449-7920	Dallas	(214) 934-9099
ILLINOIS	(312) 773-4422	Houston	(713) 785-9001
INDIANA	(317) 244-7207	WASHINGTON	(206) 455-3600
KANSAS	(913) 451-3115	WISCONSIN	(414) 782-7748
MARYLAND	(301) 796-9310		

INTERNATIONAL SALES OFFICES

BELGIUM,		ITALY, Milan	TEL:	(02) 3390541
Bruxelles	TEL:		FAX:	(02) 3498000
	FAX:		TLX:	315286
	TLX:			
		JAPAN,		
CANADA, Ontario,		Tokyo	TEL:	(03) 345-8241
Kanata	TEL:		FAX:	3425196
Willowdale	TEL:		TLX:	J24064 AMDTKOJ
	FAX:		TEL:	06-243-3250
			FAX:	06-243-3253
FRANCE,		KOREA, Seoul	TEL:	82-733-1021/7
Paris	TEL:		FAX:	82-733-1028
	FAX:		TLX:	K22652
	TLX:			
		LATIN AMERICA,		
GERMANY,		Ft. Lauderdale	TEL:	(305) 484-8600
Hannover area	TEL:		FAX:	(305) 485-9736
	FAX:		TLX:	5109554261 AMDFTL
	TLX:		TEL:	(08) 733 03 50
		SWEDEN, Stockholm	FAX:	(08) 733 22 85
			TLX:	11602
		UNITED KINGDOM,		
		Manchester area	TEL:	(0925) 828008
			FAX:	(0925) 827693
			TLX:	628524
			TEL:	(04862) 22121
			FAX:	(04862) 22179
			TLX:	859103
HONG KONG,		London area		
Kowloon	TEL:			
	FAX:			
	TLX:			

NORTH AMERICAN REPRESENTATIVES

CALIFORNIA		NEW MEXICO	
I ² INC	OEM (408) 988-3400	THORSON DESERT STATES	(505) 293-8555
	DISTI (408) 496-6868	NEW YORK	
IDAHO		NYCOM, INC	(315) 437-8343
INTERMOUNTAIN TECH MKGT	(208) 888-6071	OHIO	
INDIANA		Dayton	
SAI MARKETING CORP	(317) 241-9276	DOLFUSS ROOT & CO	(513) 433-6776
IOWA		Strongsville	
LORENZ SALES	(319) 377-4666	DOLFUSS ROOT & CO	(216) 238-0300
MICHIGAN		PENNSYLVANIA	
SAI MARKETING CORP	(313) 750-1922	DOLFUSS ROOT & CO	(412) 221-4420
NEBRASKA		UTAH	
LORENZ SALES	(402) 475-4660	R ² MARKETING	(801) 595-0631

Advanced Micro Devices reserves the right to make changes in its product without notice in order to improve design or performance characteristics. The performance characteristics listed in this document are guaranteed by specific tests, correlated testing, guard banding, design and other practices common to the industry. For specific testing details, contact your local AMD sales representative. The company assumes no responsibility for the use of any circuits described herein.