

# CA-NFKF

---



Type N Female to 4.1-9.5 DIN Female Adapter

**OBSOLETE**

## Product Classification

**Product Type** Adapter

## General Specifications

**Body Style** Straight

**Inner Contact Plating** Silver

**Interface** 4.1-9.5 DIN Female

**Interface 2** N Female

**Mounting Angle** Straight

**Outer Contact Plating** Trimetal

**Pressurizable** No

## Dimensions

**Width** 19.88 mm | 0.783 in

**Length** 35 mm | 1.378 in

**Diameter** 19.88 mm | 0.783 in

## Outline Drawing

# CA-NFKF

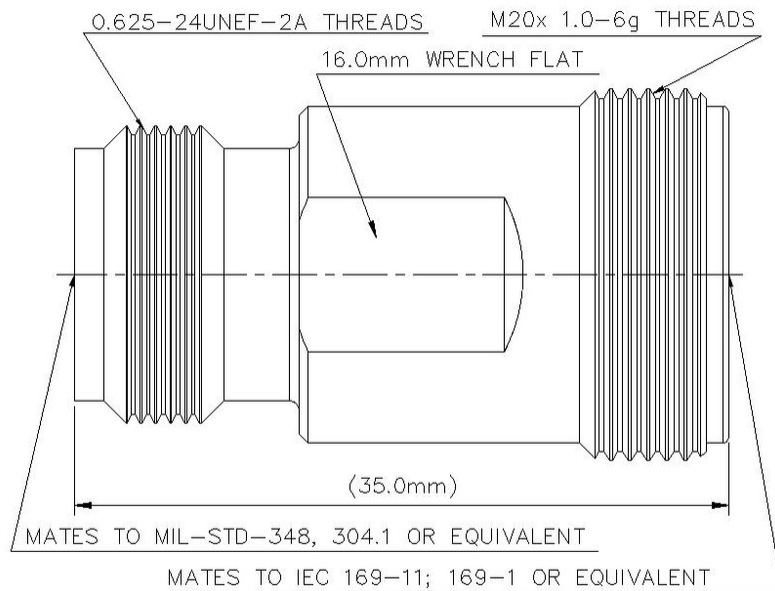

## Electrical Specifications

<b>Average Power at Frequency</b>	600.0 W @ 900 MHz
<b>Connector Impedance</b>	50 ohm
<b>dc Test Voltage</b>	2500 V
<b>Inner Contact Resistance, maximum</b>	1.5 mOhm
<b>Insulation Resistance, minimum</b>	5000 MOhm
<b>Operating Frequency Band</b>	0 – 6000 MHz
<b>Outer Contact Resistance, maximum</b>	0.4 mOhm
<b>Peak Power, maximum</b>	10 kW
<b>RF Operating Voltage, maximum (vrms)</b>	707 V

## VSWR/Return Loss

Frequency Band	VSWR	Return Loss (dB)
0-3000 MHz	1.03	38
3000-6000 MHz	1.09	28

## Mechanical Specifications

# CA-NFKF

---

<b>Coupling Nut Proof Torque</b>	17 N-m   150.463 in lb
<b>Coupling Nut Proof Torque Method</b>	IEC 61169-4:17
<b>Coupling Nut Retention Force</b>	550 N   123.645 lbf
<b>Coupling Nut Retention Force Method</b>	IEC 61169-4:15.2.6
<b>Insertion Force</b>	27 N   6.07 lbf
<b>Insertion Force Method</b>	IEC 61169-16:9.3.5
<b>Interface Durability</b>	500 cycles
<b>Interface Durability Method</b>	IEC 61169-16:9.5   IEC 61169-4:17
<b>Mechanical Shock Test Method</b>	IEC 60068-2-27

## Environmental Specifications

<b>Operating Temperature</b>	-55 °C to +85 °C (-67 °F to +185 °F)
<b>Storage Temperature</b>	-65 °C to +125 °C (-85 °F to +257 °F)
<b>Attenuation, Ambient Temperature</b>	20 °C   68 °F
<b>Average Power, Ambient Temperature</b>	40 °C   104 °F
<b>Average Power, Inner Conductor Temperature</b>	100 °C   212 °F
<b>Climatic Sequence Test Method</b>	IEC 60068-1
<b>Corrosion Test Method</b>	IEC 60068-2-11
<b>Damp Heat Steady State Test Method</b>	IEC 60068-2-3
<b>Thermal Shock Test Method</b>	IEC 60068-2-14
<b>Vibration Test Method</b>	IEC 60068-2-6

## Packaging and Weights

<b>Weight, net</b>	49.26 g   0.109 lb
--------------------	--------------------

## Regulatory Compliance/Certifications

### Agency

ISO 9001:2015



### Classification

Designed, manufactured and/or distributed under this quality management system