

Avantek Products

## Analog Level Detectors 10 to 1000 MHz

### Technical Data

#### UTD-1000/1001

#### Features

- **-120 mV Output for -10 dBm Pin**
- **$\pm 1.0$  dB Flatness**
- **50- or 300-Ohm Impedance**

#### Applications

- **Specifically Designed for System Built-in Test**
- **RF/IF Monitor**
- **Level Control**
- **UTD-1001 Can Be Used Without a Coupler in Many Cases**

#### Description

The UTD-1000 has an input impedance of 50 ohms. The UTD-1001 has an input impedance of greater than 300 ohms. In all other respects the detectors are similar. The level detector consists of an amplifier stage that drives a Schottky-barrier detector diode. Matched back-to-back silicon diodes which are closely thermally-coupled to the detector provide a DC tracking reference.

#### Pin Configuration TO-8F

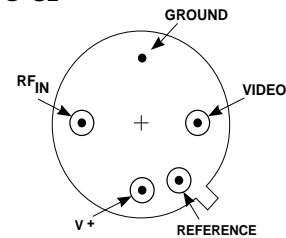

#### Schematic

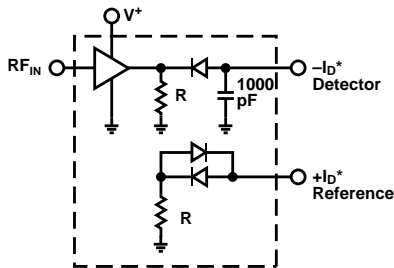

\* Requires external bias resistors see "Application Note", Section 7.

#### Maximum Ratings

Parameter	Maximum
Bias Current (diode)	1 mA
Continuous RF Input Power	+17.0 dBm
Operating Case Temperature	-54°C to +125°C
Storage Temperature	-62°C to +150°C
"R" Series Burn-In Temperature	+125°C
Pulse Input Power (1.0 minute max.)	100 mW
Junction Temperature Above Case Temperature	3°C

**Weight:** (typical) 2.1 grams

## Electrical Specifications

(Measured in 50  $\Omega$  system @ +15 VDC nominal)

Symbol	Characteristic	Typical $T_c = 25^\circ\text{C}$	Guaranteed Specifications		Unit
			$T_c = 0 \text{ to } 50^\circ\text{C}$	$T_c = -55 \text{ to } +85^\circ\text{C}$	
—	Detected Voltage (Min.) $f = 500 \text{ MHz}$ , cond. <sup>1,2</sup>	-120	-90	—	mV
—	Flatness (referred to input) (Max.) $f = 10\text{-}1000 \text{ MHz}$ , cond. <sup>1,2</sup>	$\pm 0.7$	$\pm 1.0$	—	dB
—	Variation Over Temperature (referred to input), $f = 500 \text{ MHz}$ , cond. <sup>1,2,3</sup>	$\pm 1.0$	—	—	dB
—	Input VSWR, 50 $\Omega$ (UTD-1000 only) (Max.) $f = 10\text{-}500 \text{ MHz}$	1.5:1	1.7:1	—	—
—	Input Impedance (UTD-1001 only) Equivalent resistance Equivalent capacitance	300 $\Omega$ 3.3 pf	— —	— —	— —
—	Input 3rd Order Intercept Point $f = 10\text{-}500 \text{ MHz}$	+20	—	—	dBm
—	Output Offset Voltage (Max.) $I_D = I_{REF} = 50 \mu\text{A}$ , no RF drive	$\pm 10.0$	$\pm 15.0$	—	mV
—	Differential Voltage Tracking	$\pm 5.0$	—	—	mV
—	Output Capacitance	1000	1300	—	pf

- Conditions:
1.  $I_D = 50 \mu\text{A}$ ,  $R = 10\text{K } \Omega$
  2.  $P_{IN} = -10 \text{ dBm}$  (RF input)
  3. Typical variation over  $-55^\circ$  to  $+85^\circ\text{C}$

## Product Options

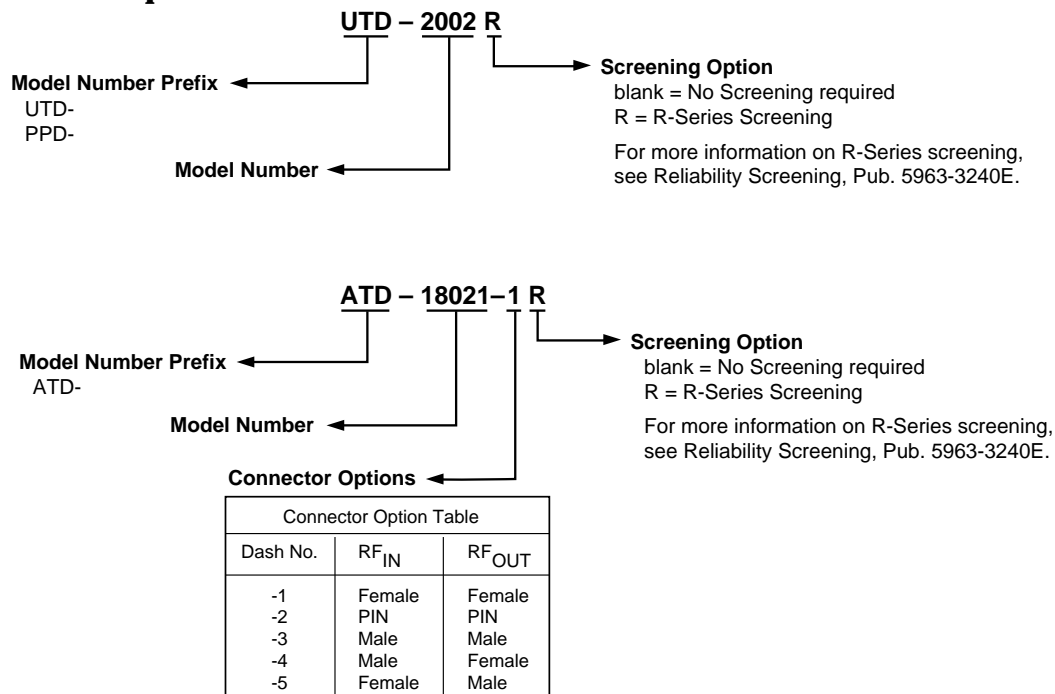

Contact your nearest HP sales office and/or distributor for assistance in ordering this product.

### Typical Performance @ 25°C

Key: +25°C ———  
 +85°C - - - -  
 -55°C = = = =

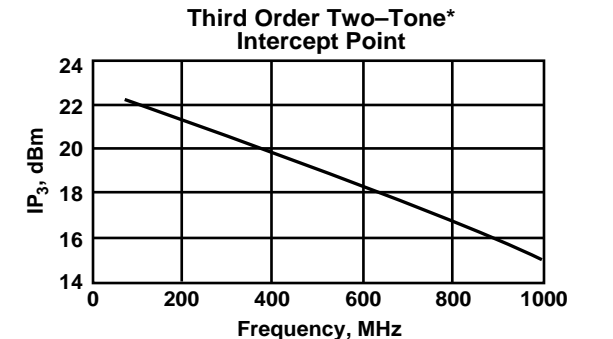
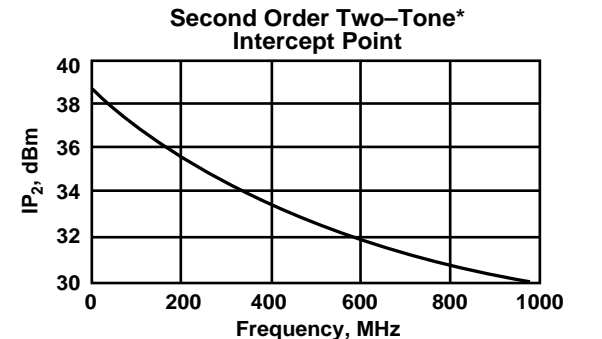
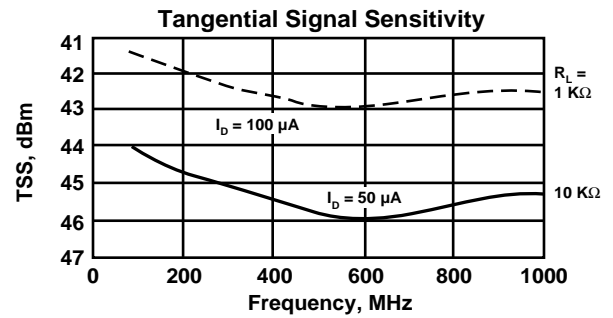
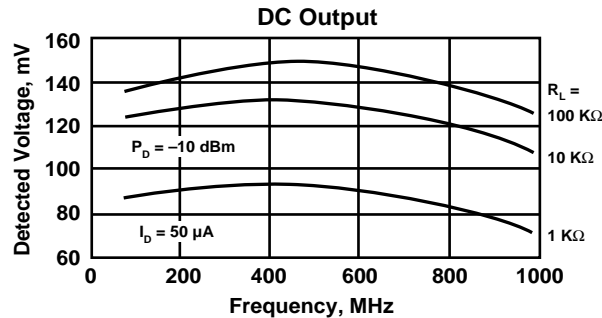
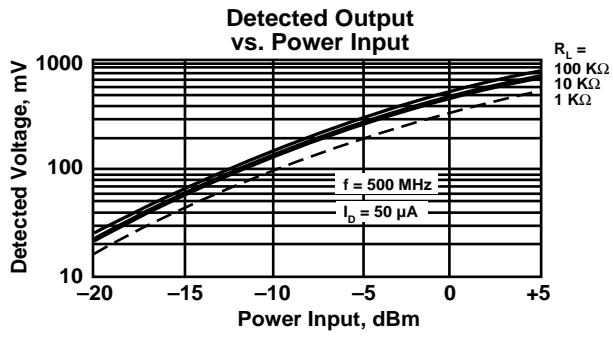
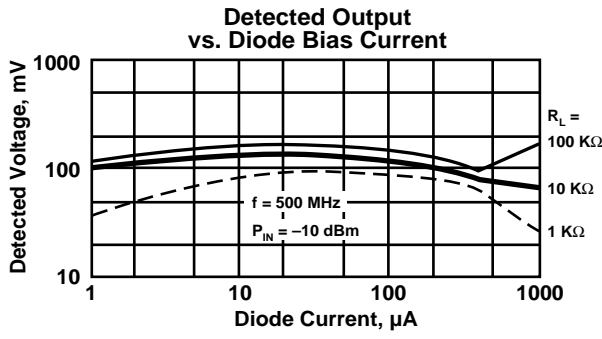

\* Distortion Curves relative to the UTD-1001 operated in shunt with a 50Ω RF line.  
 (See "Application Note" in Section 7.)

# H

## Case Drawings TO-8F

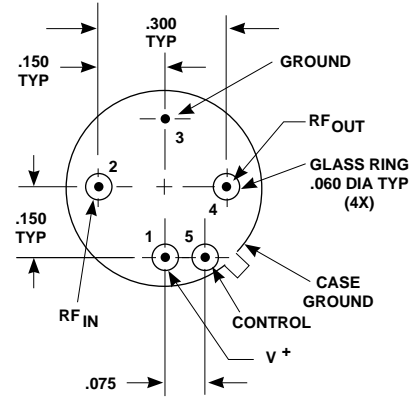
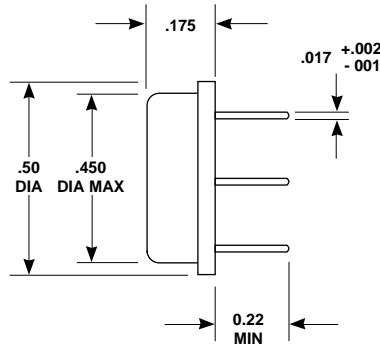
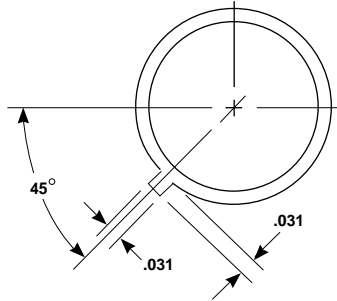

APPROXIMATE WEIGHT 2.1 GRAMS

- NOTES (UNLESS OTHERWISE SPECIFIED):  
1. DIMENSIONS ARE SPECIFIED IN INCHES  
2. TOLERANCES: xx ± .02  
xxx ± .010

For more information:

United States\*

Europe\*

Far East/Australasia: (65) 290-6305

Canada: (416) 206-4725

Japan: (81 3) 3331-6111

\*Call your local HP sales office listed in your telephone directory. Ask for a Components representative.

Data Subject to Change  
Copyright © 1995 Hewlett-Packard Co.

Printed in U.S.A. 5963-3250E (10/94)