

ASSP For Video Applications

CMOS

3 ch 8-bit 100 MSPS A/D Converter

MB40C348

■ DESCRIPTION

MB40C348 is a high-speed 3ch A/D converter using a fast CMOS technology.

■ FEATURES

- Resolution : 8 bit
- No. of AD channels : 3 ch
- Linearity error : $\pm 0.40\%$ (typical)
- Maximum conversion rate : 100 MSPS (minimum)
- Power supply voltage : 3.3 V (typical: internal circuit)
- Digital input voltage range : TTL level
- Digital output voltage range : 3.3 V CMOS level
- Amp. input voltage range : 0.7 V_{P-P} (typical)
- Amp. gain : 1.9 double fixed
- Power dissipation : 880 mW (typical)
- Additional features : PLL circuit
Video Amp. circuit (1.9 double fixed gain)
CLAMP circuit
V_{RT} Amp. circuit (RGB 3 ch common)
V_{RB} Amp. circuit (RGB 3 ch common)
Overflow output
High impedance output, power down function
- Package : LQFP120 (16 mm × 16mm, lead pitch : 0.5 mm)

■ PACKAGE

120-pin plastic LQFP

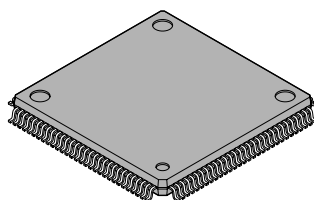

(FPT-120P-M21)

■ PIN DESCRIPTION

Pin No.	Symbol	Description
9, 23, 47, 79, 107	AV _{DD}	Analog power supply (+3.3 V)
28, 38, 50, 59, 70, 82, 93, 106	DV _{DD}	Digital power supply (+3.3 V)
116, 119	PV _{DD}	PLL power supply (+3.3 V)
14	V _{ESD}	Digital input power supply for protect device (+3.3 V or +5 V)
10, 22, 48, 80, 91, 108	AV _{SS}	Analog power supply ground pin (0 V)
27, 37, 49, 60, 69, 81, 92, 105	DV _{SS}	Digital power supply ground pin (0 V)
114, 120	PV _{SS}	PLL power supply ground pin (0 V)
1 3 5	RV _{IN} GV _{IN} BV _{IN}	1.9 double Amp. input pin
11 13 15	RADIN GADIN BADIN	A/D converter input pin Please set these pins to open usually.
19 20 21	RV _{CLP} GV _{CLP} BV _{CLP}	Clamp voltage setting input pin
110	V _{RTM}	Reference voltage output pin on top side
111	V _{RT}	Reference voltage input pin on top side
112	V _{REFT}	Reference voltage generator output pin on top side
16	V _{RBM}	Reference voltage output pin on bottom side
17	V _{RB}	Reference voltage input pin on bottom side
18	V _{REFB}	Reference voltage generator output pin on bottom side
6 2 109	V _{R1} V _{R2} V _{R3}	Reference 1/4 voltage output pin (Add 0.1 μF for AV _{SS}) Reference 1/2 voltage output pin (Add 0.1 μF for AV _{SS}) Reference 3/4 voltage output pin (Add 0.1 μF for AV _{SS})
12	DSEL	Mode of operation setting input pin (Refer to ■ MODE SETTING)
25	CK	Serial data transfer clock input pin
26	DATA	Serial data input pin
24	\overline{CS}	Chip select signal input pin It is possible to input to the shift register at \overline{CS} falling The content of the shift register is executed at \overline{CS} rising
98	EXCLK	Clock input pin for A/D converter (CMOS level) Fix to "L" level when unused.

Note: The values in parentheses are standard.

(Continued)

MB40C348

(Continued)

Pin No.	Symbol	Description	
99	EXPCLKB	Differential clock (positive-phase) input pin for A/D converter Fix to "H" level when unused.	PECL level
100	EXPCLK	Differential clock (negative-phase) input pin for A/D converter Fix to "L" level when unused.	
8	PCLP	Clamp pulse input pin	
4	\overline{CE}	Power down at \overline{CE} input "H" level (internal pull-up resistor)	
113	R _{REF}	Internal current setting pin (Add 12k Ω for AVss)	
103	DSYNC	Delay sync signal output pin	
102	DSYNCB	Inverted delay sync signal output pin	
95	CLK	Clock output pin (See " ■ TIMING DIAGRAM ".)	
94	CLKB		
97	ADCLKA		
96	ADCLKB		
83 to 90 61 to 68 39 to 46	RD _{A7} to RD _{A0} GD _{A7} to GD _{A0} BD _{A7} to BD _{A0}	Digital output pin (Port A) RD _{A7} , GD _{A7} , BD _{A7} : MSB RD _{A0} , GD _{A0} , BD _{A0} : LSB	
71 to 78 51 to 58 29 to 36	RD _{B7} to RD _{B0} GD _{B7} to GD _{B0} BD _{B7} to BD _{B0}	Digital output pin (Port B) RD _{B7} , GD _{B7} , BD _{B7} : MSB RD _{B0} , GD _{B0} , BD _{B0} : LSB	
101	COUT	PLL counter output pin	
115	LPF	External capacitor / resistor connection pin	
117	HHOLD	Phase detector operation is hold by input "H" level	
118	HSYNC	Horizontal sync signal input pin	
7	V _{REF}	Internal voltage output pin (Add 3.3 μ F for AVss)	
104	OF	Overflow output pin ("H" level output at overflow)	

Note: The values in parentheses are standard.

■ BLOCK DIAGRAM

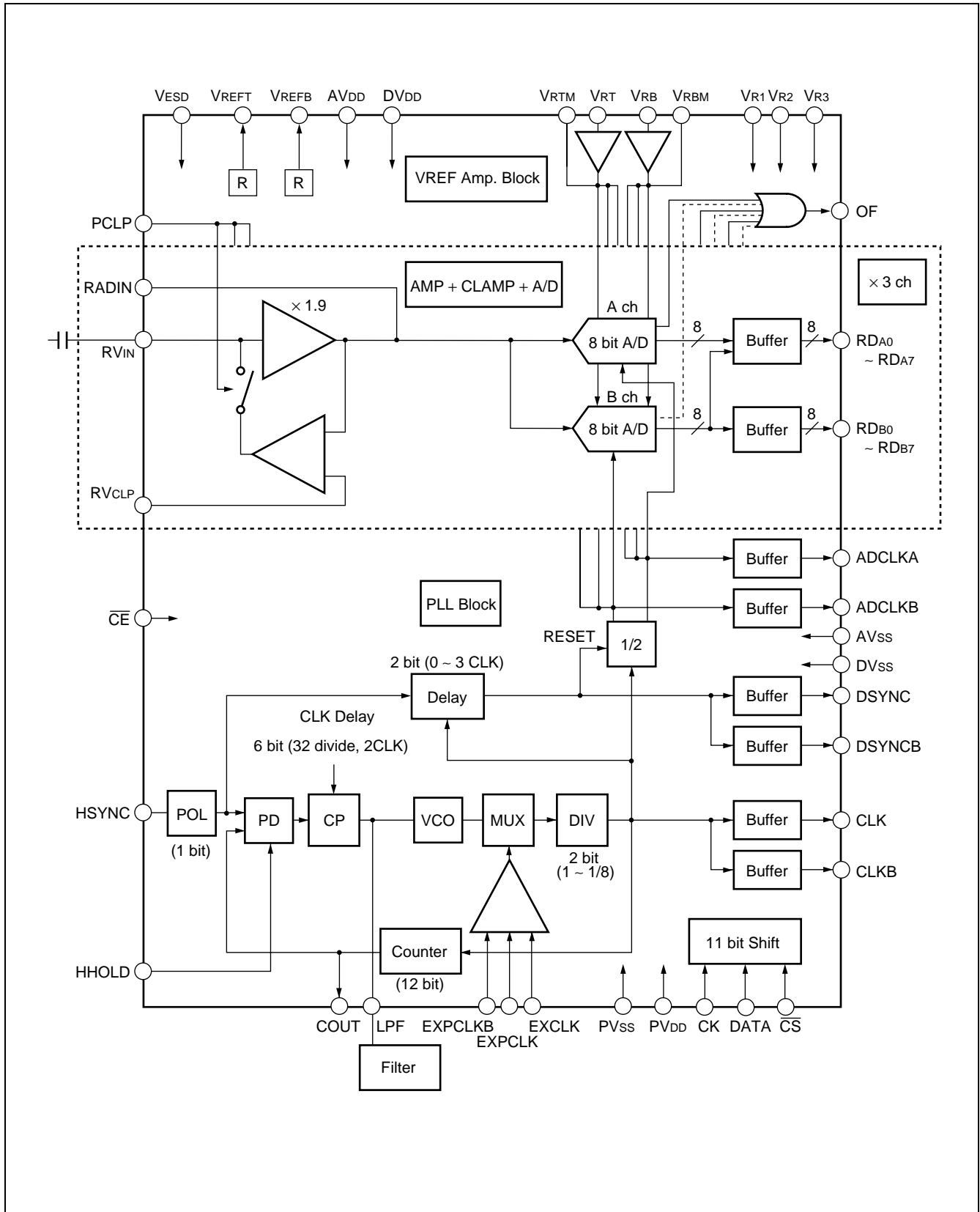

MB40C348

■ ABSOLUTE MAXIMUM RATINGS

Parameter	Symbol	Rating		Unit
		Min.	Max.	
Power supply voltage	$AV_{DD}, DV_{DD}, PV_{DD}$	-0.3	+4.0	V
	V_{ESD}	-0.3	+7.0	V
Input/output voltage	$RV_{IN}, GV_{IN}, BV_{IN},$ $RADIN, GADIN, BADIN,$ $RV_{CLP}, GV_{CLP}, BV_{CLP},$ $V_{RT}, V_{RTM}, V_{REFT},$ $V_{RB}, V_{RBM}, V_{REFB},$ V_{R1}, V_{R2}, V_{R3} V_{REF}, R_{REF}	-0.3	$AV_{DD}+0.3^{*1}$	V
	$RD_{A0} \text{ to } RD_{A7}, RD_{B0} \text{ to } RD_{B7},$ $GD_{A0} \text{ to } GD_{A7}, GD_{B0} \text{ to } GD_{B7},$ $BD_{A0} \text{ to } BD_{A7}, BD_{B0} \text{ to } BD_{B7},$ $DSYNC, DSYNCB, OF,$ $COU, CLK, CLKB,$ $ADCLKA, ADCLKB$	-0.3	$DV_{DD}+0.3^{*1}$	V
	LPF	-0.3	$PV_{DD}+0.3^{*1}$	V
	$DSEL, CK, DATA, \overline{CS},$ $EXPCLKB, EXPCLK,$ $PCLP, \overline{CE}, EXCLK,$ $HHOLD, HSYNC$	-0.3	$V_{ESD}+0.3^{*2}$	V
Storage temperature	T_{STG}	-55	+125	°C

*1 : Do not exceed +4.0 V.

*2 : Do not exceed +7.0 V.

WARNING: Semiconductor devices can be permanently damaged by application of stress (voltage, current, temperature, etc.) in excess of absolute maximum ratings. Do not exceed these ratings.

■ RECOMMENDED OPERATING CONDITIONS

Parameter	Symbol	Value			Unit
		Min.	Typ.	Max.	
Power supply voltage	AV_{DD}, DV_{DD}	3.00	3.30	3.60	V
	PV_{DD}	3.00	3.30	3.60	V
	V_{ESD}	3.00	—	5.25	V
A/D converter input voltage	V_{ADIN}	V_{RB}	—	V_{RT}	V
Analog reference voltage : T	V_{RT}	—	2.2	$AV_{DD} - 0.6$	V
Analog reference voltage : B	V_{RB}	0.6	0.7	—	V
Analog reference voltage range	$V_{RT} - V_{RB}$	1.0	1.5	1.8	V
Video Amp. input voltage	$V_{IN (P-P)}$	0.5	—	0.9	V_{P-P}
Clamp input voltage	V_{CLP}	0.6	V_{RB}	1.7	V
Digital “H” level input voltage	V_{IHD}	2.5	—	V_{ESD}	V
Digital “L” level input voltage	V_{ILD}	0	—	0.5	V
Digital “H” level output current	I_{OHD}	−400	—	—	μA
Digital “L” level output current	I_{OLD}	—	—	1.6	mA
PLL counter	P_C	100	—	4095	—
HSYNC input frequency range	f_{HSYNC}	10	—	100	kHz
HHOLD set up time	t_{sHHOLD}	20	—	—	ns
HHOLD hold time	t_{hHHOLD}	20	—	—	ns
Clamp pulse width	t_{wCLP}	0.5	—	—	μs
CK clock pulse width	t_{wCKL}, t_{wCKH}	100	—	—	ns
DATA set up time	t_{sDATA}	30	—	—	ns
DATA hold time	t_{hDATA}	30	—	—	ns
\overline{CS} set up time	t_{sCS}	50	—	—	ns
\overline{CS} hold time	t_{hCS}	50	—	—	ns
\overline{CS} “H” level hold time	t_{wCSH}	100	—	—	ns
Operating temperature range	T_a	−20	—	70	$^{\circ}C$

WARNING: The recommended operating conditions are required in order to ensure the normal operation of the semiconductor device. All of the device's electrical characteristics are warranted when the device is operated within these ranges.

Always use semiconductor devices within their recommended operating condition ranges. Operation outside these ranges may adversely affect reliability and could result in device failure.

No warranty is made with respect to uses, operating conditions, or combinations not represented on the data sheet. Users considering application outside the listed conditions are advised to contact their FUJITSU representatives beforehand.

MB40C348

■ ELECTRICAL CHARACTERISTICS

1. DC Characteristics in Analog Section

- Power supply current ($AV_{DD} = DV_{DD} = PV_{DD} = 3.0\text{ V to }3.6\text{ V}$, $V_{ESD} = 3.0\text{ V to }5.25\text{ V}$, $T_a = -20\text{ }^\circ\text{C to }+70\text{ }^\circ\text{C}$)

Parameter	Symbol	Value			Unit
		Min.	Typ.	Max.	
Analog power supply current	I_{DD}	—	170	290	mA
Digital power supply current	$D I_{DD}$	—	80	90	mA
Power supply current PLL section (@ $f_{VCOH} = 162\text{ MHz}$, $I_{CP} = 0.5\text{ mA}$, $DIV = 1/1$)	$P I_{DD}$	—	16	20	mA
Standby current	I_{SB}	—	10	—	mA

- Block A/D ($AV_{DD} = DV_{DD} = PV_{DD} = 3.0\text{ V to }3.6\text{ V}$, $V_{ESD} = 3.0\text{ V to }5.25\text{ V}$, $T_a = -20\text{ }^\circ\text{C to }+70\text{ }^\circ\text{C}$)

Parameter	Symbol	Value			Unit
		Min.	Typ.	Value	
Resolution	—	—	8	—	bit
Linearity error (DC Accuracy)	LE	-0.8	± 0.4	+0.8	%
Differential linearity error (DC Accuracy)	DLE	-0.36	± 0.2	+0.65	%
Reference voltage : T	V_{REFT}	$0.63 \times AV_{DD}$	$0.67 \times AV_{DD}$	$0.70 \times AV_{DD}$	V
Reference voltage : B	V_{REFB}	$0.18 \times AV_{DD}$	$0.21 \times AV_{DD}$	$0.24 \times AV_{DD}$	V
Analog reference voltage input current	I_{RT}, I_{RB}	—	5	20	μA

- Video Amp. Block ($AV_{DD} = DV_{DD} = PV_{DD} = 3.0\text{ V to }3.6\text{ V}$, $V_{ESD} = 3.0\text{ V to }5.25\text{ V}$, $T_a = -20\text{ }^\circ\text{C to }+70\text{ }^\circ\text{C}$)

Parameter	Symbol	Value			Unit
		Min.	Typ.	Value	
Video Amp. gain	G_{AMP}	1.8	1.9	2.0	—
Video Amp. output voltage range	V_{AMPOUT}	0.5	—	$AV_{DD} - 0.6$	V
Video Amp. frequency width	BW	—	170	—	MHz
Video Amp. input capacity	C_{VIN}	—	5	—	pF

- CLAMP Block ($AV_{DD} = DV_{DD} = PV_{DD} = 3.0\text{ V to }3.6\text{ V}$, $V_{ESD} = 3.0\text{ V to }5.25\text{ V}$, $T_a = -20\text{ }^\circ\text{C to }+70\text{ }^\circ\text{C}$)

Parameter	Symbol	Value			Unit
		Min.	Typ.	Value	
V_{CLP} input current	I_{CLP}	—	5	20	μA
Clamp voltage	V_{CLAMP}	$V_{CLP} - 0.1$	V_{CLP}	$V_{CLP} + 0.1$	V

- PLL Block ($AV_{DD} = DV_{DD} = PV_{DD} = 3.0\text{ V to }3.6\text{ V}$, $V_{ESD} = 3.0\text{ V to }5.25\text{ V}$, $T_a = -20\text{ }^\circ\text{C to }+70\text{ }^\circ\text{C}$)

Parameter	Symbol	Value			Unit
		Min.	Typ.	Value	
CLK jitter (@ $f_{HSYNC} = 68.68\text{ kHz}$, $f_{CLK} = 94.5\text{ MHz}$)	P_{ij}	—	1.0	1.5	ns

2. DC Characteristics in Digital Section

($AV_{DD} = DV_{DD} = PV_{DD} = 3.0\text{ V to }3.6\text{ V}$, $V_{ESD} = 3.0\text{ V to }5.25\text{ V}$, $T_a = -20\text{ }^\circ\text{C to }+70\text{ }^\circ\text{C}$)

Parameter	Symbol	Value			Unit
		Min.	Typ.	Max.	
Digital input current	I_{ID}	-20	—	5	μA
Digital “H” level output voltage	V_{OHD}	$DV_{DD} - 0.4$	—	—	V
Digital “L” level output voltage	V_{OLD}	—	—	0.4	V

3. Switching Characteristics

($AV_{DD} = DV_{DD} = PV_{DD} = 3.0\text{ V to }3.6\text{ V}$, $V_{ESD} = 3.0\text{ V to }5.25\text{ V}$, $T_a = -20\text{ }^\circ\text{C to }+70\text{ }^\circ\text{C}$)

Parameter	Symbol	Value			Unit	
		Min.	Typ.	Max.		
A/D maximum conversion rate	f_s	100	—	—	MSPS	
Aperture time	t_{AD}	—	1.5	—	ns	
VCO oscillation frequency	VCOL	f_{VCOL}	75	—	140	MHz
	VCOH	f_{VCOH}	85	—	162	MHz
CLK output delay time	$t_{pd}(\text{HSYNC-CLK})$	1.0	2.0	4.0	ns	
Digital output delay time	Timing diagram 1	$t_{pd}(\text{CLK-ADCLK1})$	0.0	1.0	2.0	ns
		$t_{pd}(\text{CLK-DATA1})$	2.5	4.0	6.0	ns
	Timing diagram 2	$t_{pd}(\text{CLK-ADCLK2})$	0.0	1.0	2.0	ns
		$t_{pd}(\text{CLK-DATA2})$	2.5	4.0	6.0	ns
DSYNC output delay time	$t_{pd}(\text{CLK-DSYNC})$	0.5	1.5	2.0	ns	

■ DIGITAL OUTPUT BUFFER LOAD CIRCUIT

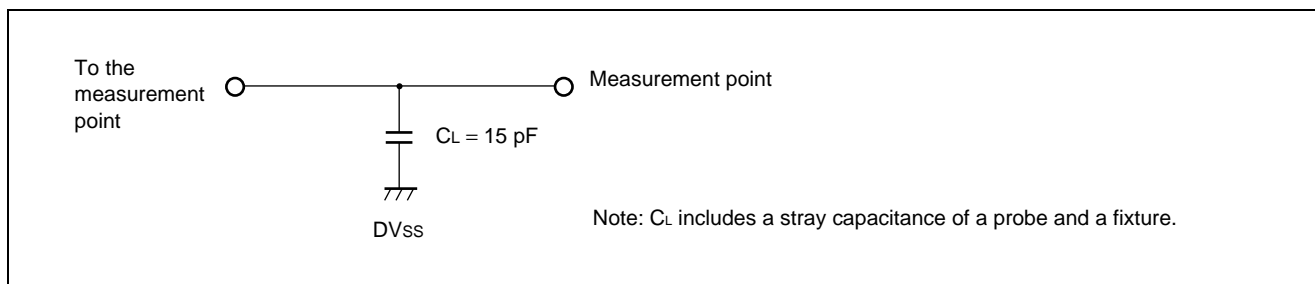

■ MODE SETTING

Pin	Setting	Mode	Timing Diagram
DSEL	H	Straight output mode	Timing diagram 1
	L	Demultiplex output (in-phase) mode	Timing diagram 2
$\overline{\text{CE}}$	H	All function power OFF	
	L	Operation mode	

MB40C348

■ SERIAL DATA SETTING (MSB Fast)

RES	(Address)			(Data)								Function
	D0	D1	D2	D3	D4	D5	D6	D7	D8	D9	D10	
1	1	0	0	0	0	0	0	0	0	1	0	Counter low ranking 8 bit
2	0	1	0	0	0	0	0	X	X	X	X	Counter high ranking 4 bit
3	1	1	0	0	0	0	0	0	0	1	0	CLK delay adjust*1 : $t_d = N / (32 \times f_{CLK})$
	1	1	0	0	0	0	0	0	0	1	0	HSYNC polarity : 0 = through, 1 = inversion
	1	1	0	0	0	0	0	0	0	1	0	A/D converter output : 0 = operation, 1 = high impedance
4	0	0	1	0	0	0	0	0	0	1	0	CLK output : 0 = on, 1 = "L"
	0	0	1	0	0	0	0	0	0	1	0	CLKB output : 0 = on, 1 = "L"
	0	0	1	0	0	0	0	0	0	1	0	DSYNC output : 0 = on, 1 = "L"
	0	0	1	0	0	0	0	0	0	1	0	DSYNCB output : 0 = on, 1 = "L"
	0	0	1	0	0	0	0	0	0	1	0	ADCLKA output : 0 = on, 1 = "L"
	0	0	1	0	0	0	0	0	0	1	0	ADCLKB output : 0 = on, 1 = "L"
	0	0	1	0	0	0	0	0	0	1	0	DSYNC delay*2 : 0, 1, 2, 3
5	1	0	1	0	0	0	0	0	0	1	0	CLK change : 0 = VCO, 1 = External clock
	1	0	1	0	0	0	0	0	0	1	0	External clock input : 0 = CMOS, 1 = PECL
	1	0	1	0	0	0	0	0	0	1	0	Counter operation : 0 = on, 1 = off
	1	0	1	0	0	0	0	0	0	1	0	Charge pump current*3 : 0.1 mA, 0.5 mA, 1 mA
	1	0	1	0	0	0	0	0	0	1	0	VCO select : 0 = VCOL, 1 = VCOH
	1	0	1	0	0	0	0	0	0	1	0	Divider setting*4 : 1, 1/2, 1/4, 1/8

*1 : Setting at 6bit, Resolution: $1/32 \times CLK$, Setting range: 0 to $63/32 \times CLK$

*2, *3, *4 : See under table

Setting	0 (0, 0)	1 (1, 0)	2 (0, 1)	3 (1, 1)
DSYNC Delay*2	0 CLK	1 CLK	2 CLK	3 CLK
Charge pump current*3	0.1 mA	0.5 mA	1.0 mA	—
Divider setting*4	1/1	1/2	1/4	1/8

Example: input at 16 bit

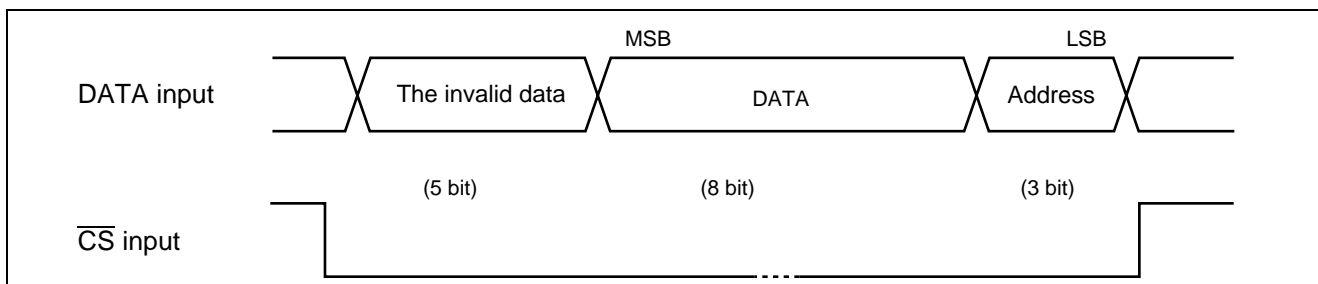

RECOMMEND VALUE OF SERIAL DATA SETTING

	f _{CLK} (MHz)	f _{HSYNC} (kHz)	Counter	I _{cp} (mA)	VCO select	Divider	f _{vco} (MHz)
XGA	94.500	68.677	1376	0.5	VCOH or VCOL	1/1	94.500
	78.750	60.023	1312	0.5	VCOL	1/1	78.750
	75.000	56.476	1328	0.5	VCOH	1/2	150.000
	65.000	48.363	1344	0.5	VCOH or VCOL	1/2	130.000
SVGA	56.250	53.674	1048	0.5	VCOH or VCOL	1/2	112.500
	50.000	48.077	1040	0.5	VCOH or VCOL	1/2	100.000
	49.500	46.875	1056	0.5	VCOH or VCOL	1/2	99.000
	40.000	37.879	1056	0.5	VCOL	1/2	80.000
VGA	36.000	43.269	832	0.5	VCOH	1/4	144.000
	31.500	37.861	832	0.5	VCOH or VCOL	1/4	126.000
	25.175	31.469	800	0.5	VCOH or VCOL	1/4	100.700
	25.149	31.436	800	0.5	VCOH or VCOL	1/4	100.596
PAL	29.375	15.625	1880	0.5	VCOH or VCOL	1/4	117.500
	22.031	15.625	1410	0.5	VCOH or VCOL	1/4	88.125
	14.688	15.625	940	0.5	VCOH or VCOL	1/8	117.500
NTSC	24.545	15.734	1560	0.5	VCOH or VCOL	1/4	98.180
	18.409	15.734	1170	0.5	VCOH	1/8	147.270
	12.273	15.734	780	0.5	VCOH or VCOL	1/8	98.180

VCO select : VCOH (f_{vco} = 85 MHz to 162 MHz)

VCOL (f_{vco} = 75 MHz to 140 MHz)

$$f_{CLK} = f_{HSYNC} \times \text{Counter}$$

$$f_{VCO} = f_{HSYNC} \times \text{Counter} / \text{Divider}$$

MB40C348

■ TIMING DIAGRAM

- Straight Output Mode (Timing Diagram 1)

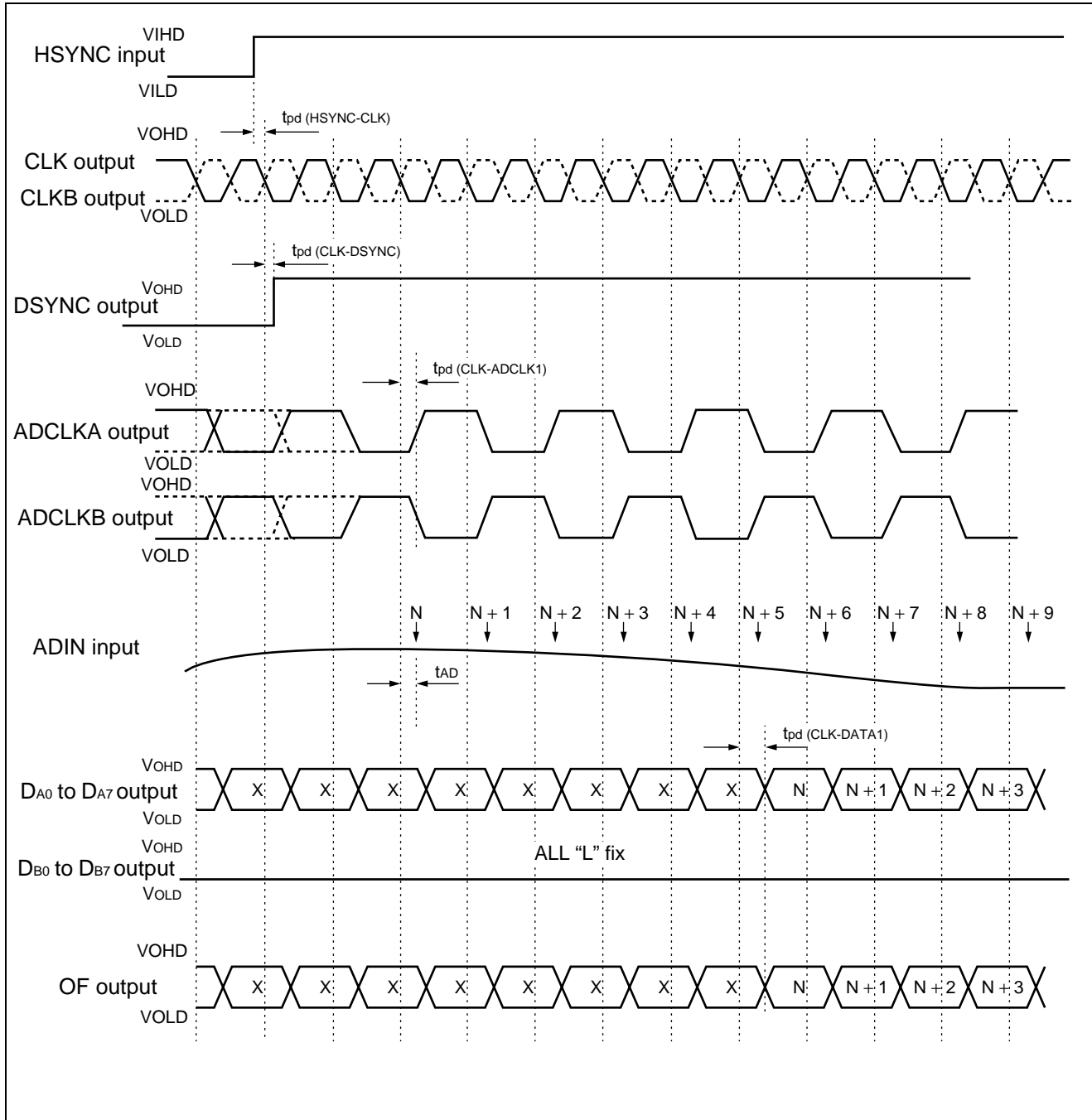

- ADIN input : Sampling at CLK rising (at CLKB falling)
- DA0 to DA7 : Output (after $5\text{CLK} + t_{pd}(\text{CLK-DATA1})$ from sampling) at CLK rising (at CLKB falling)

• Demultiplex Output (in-phase) Mode (Timing Diagram 2)

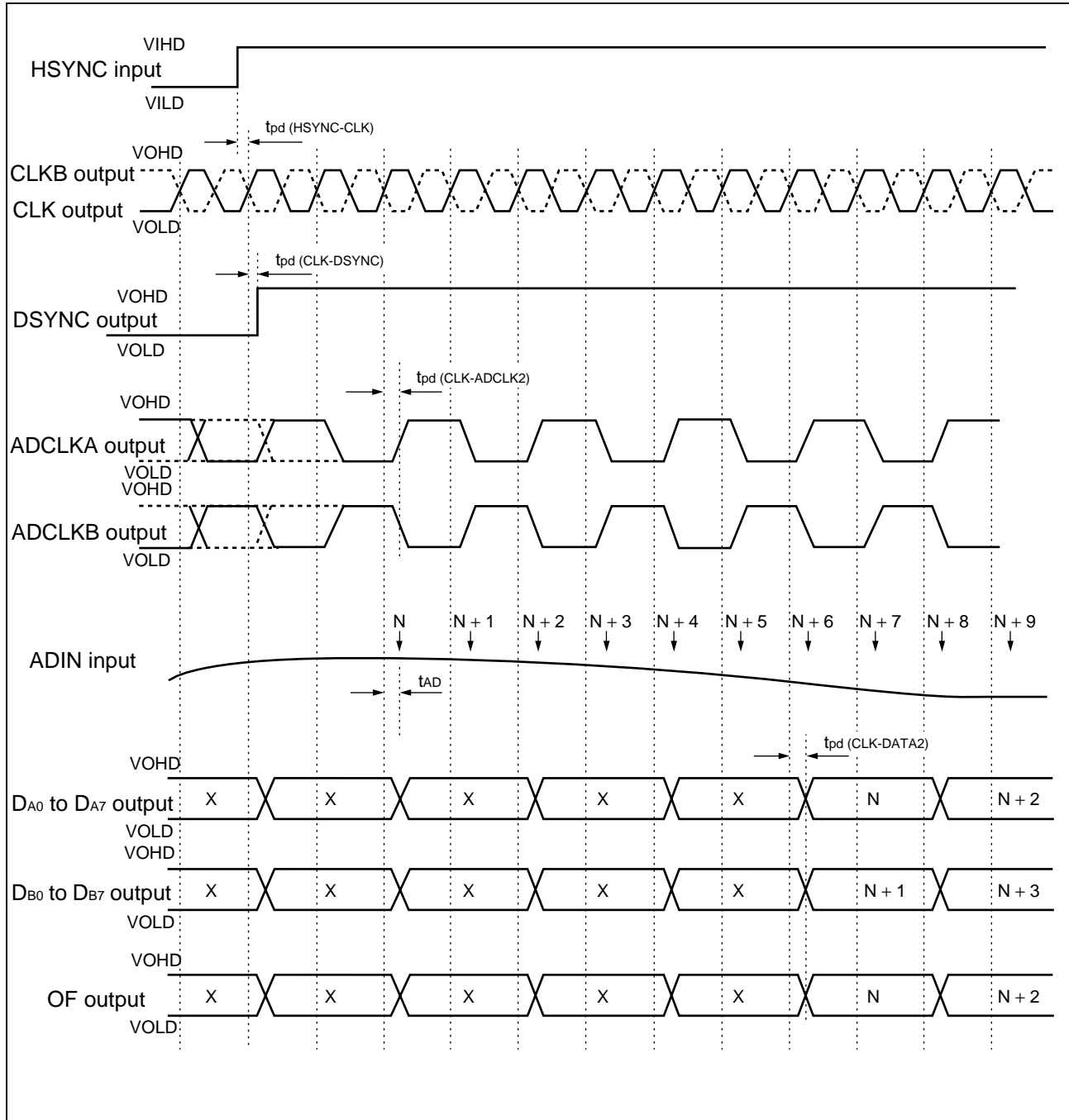

- ADIN input : Sampling at CLK rising (at CLKB falling)
- DA0 to DA7 : Output (after $6\text{CLK} + t_{pd}(\text{CLK-DATA2})$ from sampling) at CLK rising (at CLKB falling)
- DB0 to DB7 : Output (after $5\text{CLK} + t_{pd}(\text{CLK-DATA2})$ from sampling) at CLK rising (at CLKB falling)

CLAMP and Amp. OPERATION

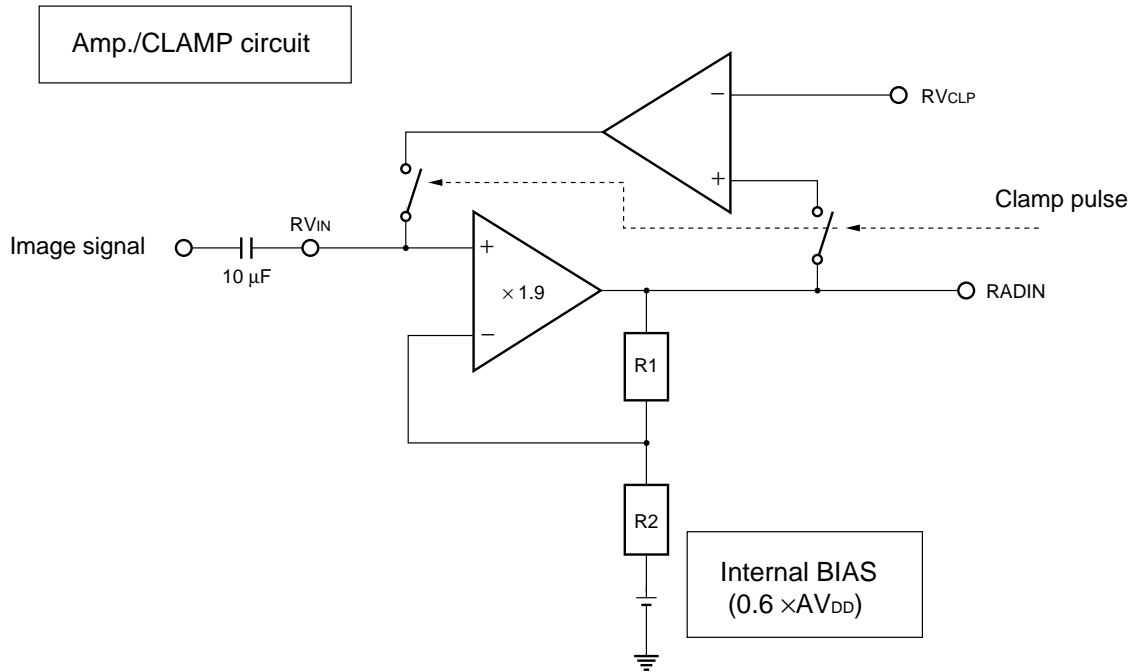

Example: Sync on G signal input >

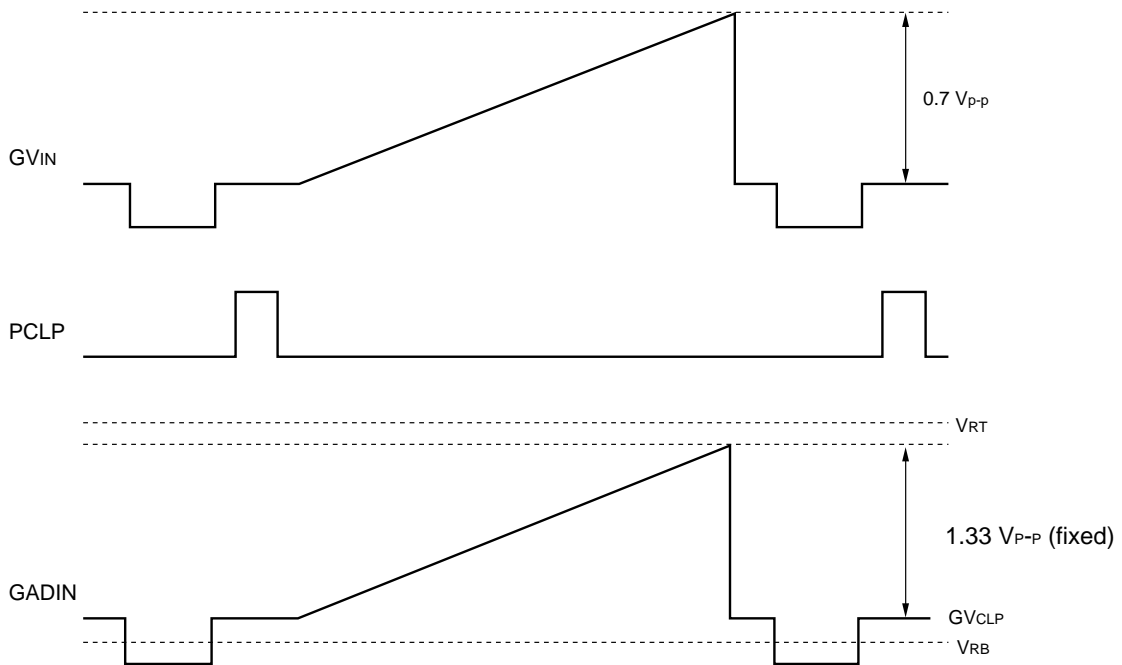

Contrast adjust : controlling the voltage difference between V_{RT} and V_{RB} (typ : $V_{RT} - V_{RB} = 1.33 \text{ V}$)
 Brightness adjust : controlling the voltage difference between V_{CLP} and V_{RB} . (typ : $V_{CLP} = V_{RB}$)

CLAMP SIGNAL and HOLD SIGNAL

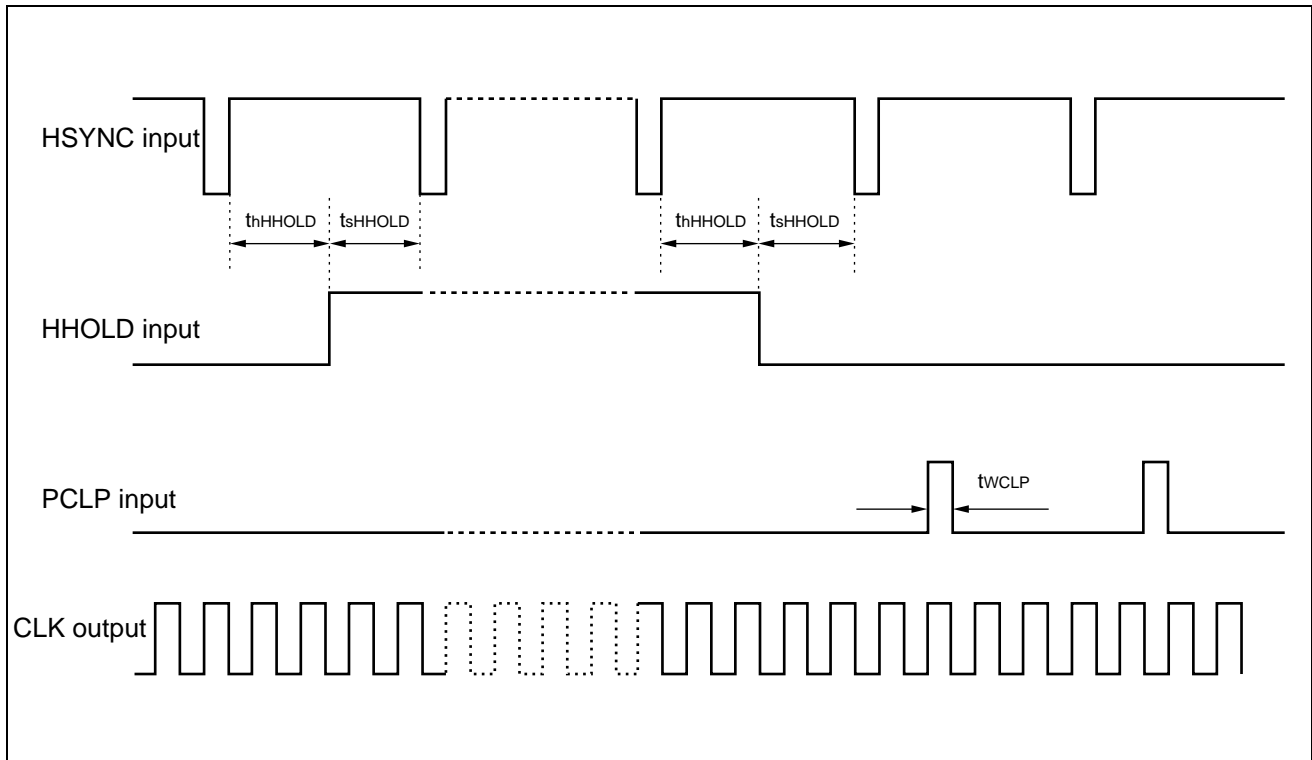

SERIAL DATA TRANSFER TIMING

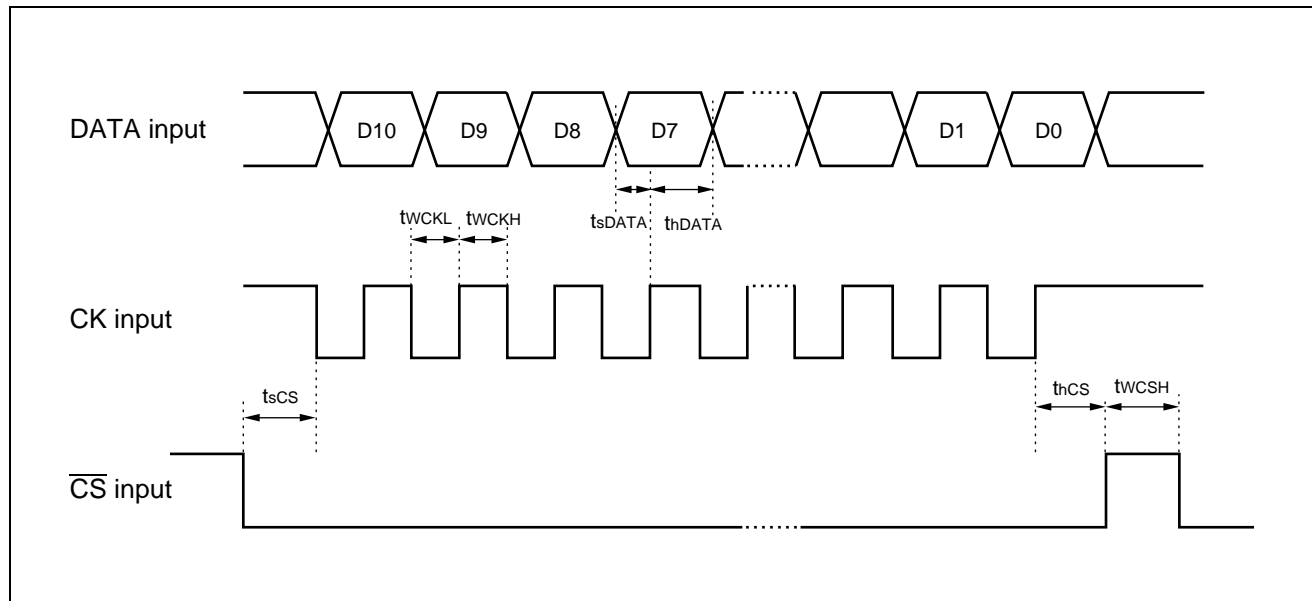

MB40C348

TYPICAL APPLICATION

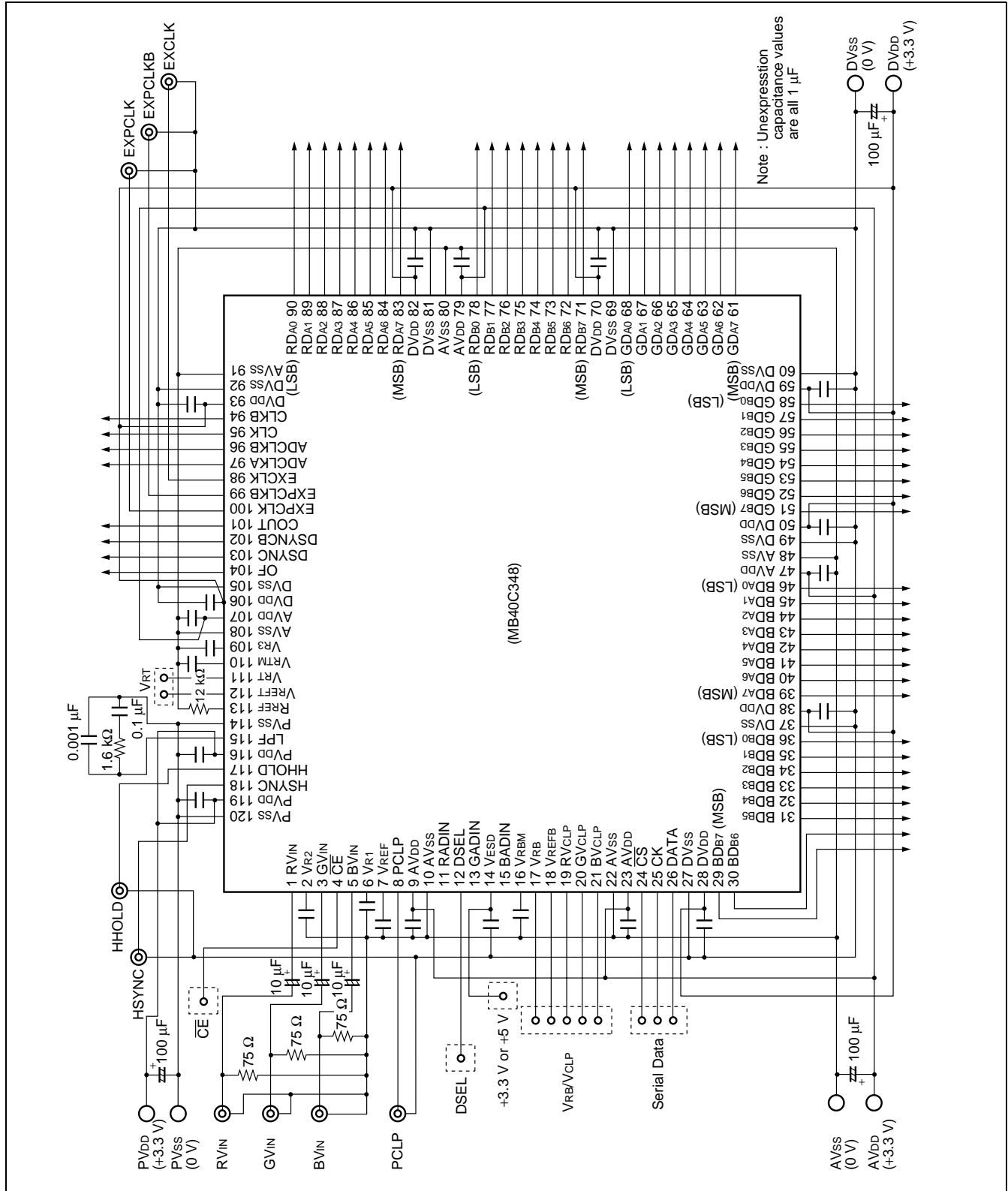

■ USAGE PRECAUTIONS

Be sure to ground the pins of AV_{DD} , DV_{DD} , PV_{DD} , V_{ESD} , V_{RTM} , V_{RBM} , V_{R1} , V_{R2} , V_{R3} , and V_{REF} via high-frequency capacitor.

Place the high-frequency capacitor as close as possible to the pin.

■ ORDERING INFORMATION

Part number	Package	Remark
MB40C348PFV	120-pin plastic LQFP (FPT-120P-M21)	

MB40C348

■ PACKAGE DIMENSION

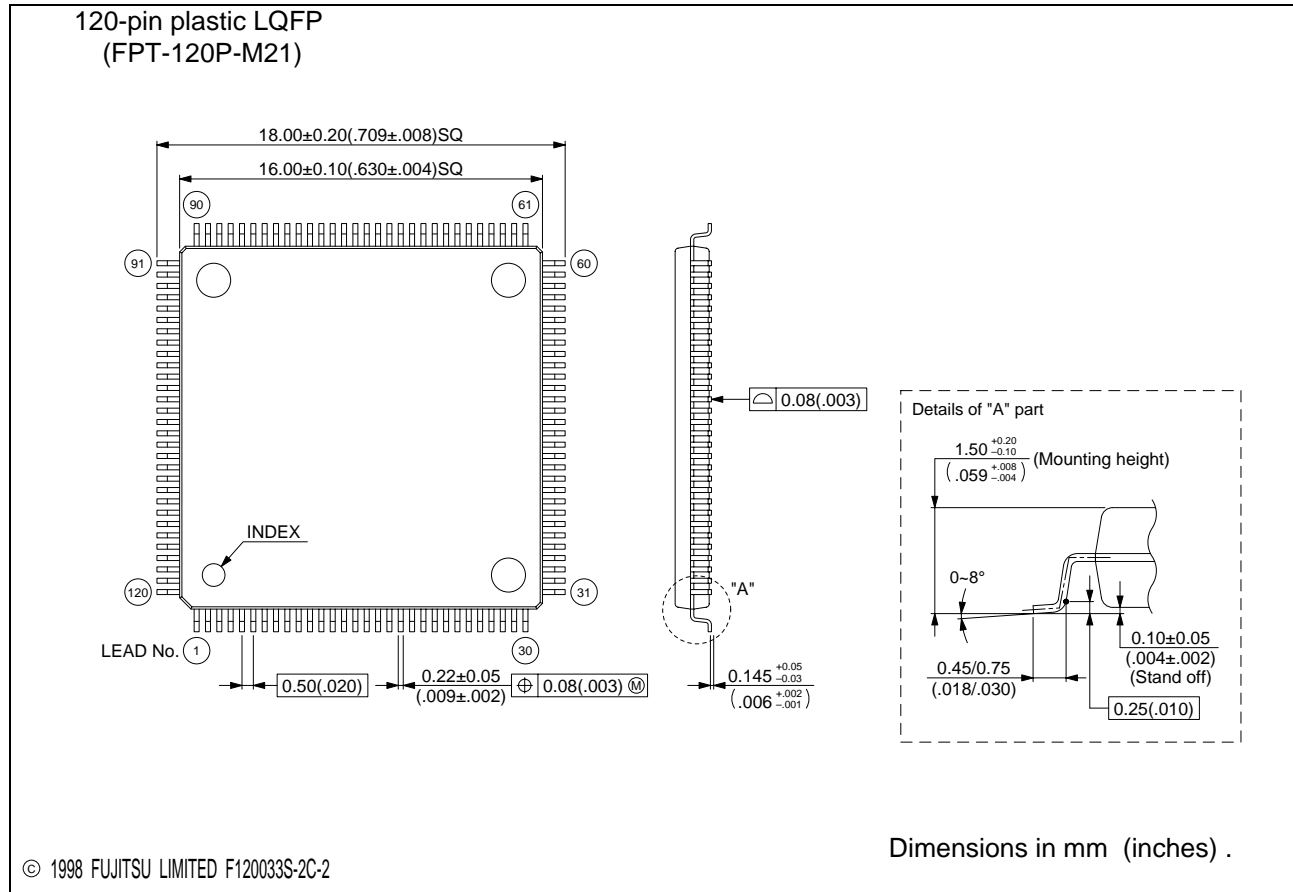

FUJITSU LIMITED

All Rights Reserved.

The contents of this document are subject to change without notice. Customers are advised to consult with FUJITSU sales representatives before ordering.

The information and circuit diagrams in this document are presented as examples of semiconductor device applications, and are not intended to be incorporated in devices for actual use. Also, FUJITSU is unable to assume responsibility for infringement of any patent rights or other rights of third parties arising from the use of this information or circuit diagrams.

The products described in this document are designed, developed and manufactured as contemplated for general use, including without limitation, ordinary industrial use, general office use, personal use, and household use, but are not designed, developed and manufactured as contemplated (1) for use accompanying fatal risks or dangers that, unless extremely high safety is secured, could have a serious effect to the public, and could lead directly to death, personal injury, severe physical damage or other loss (i.e., nuclear reaction control in nuclear facility, aircraft flight control, air traffic control, mass transport control, medical life support system, missile launch control in weapon system), or (2) for use requiring extremely high reliability (i.e., submersible repeater and artificial satellite).

Please note that Fujitsu will not be liable against you and/or any third party for any claims or damages arising in connection with above-mentioned uses of the products.

Any semiconductor devices have an inherent chance of failure. You must protect against injury, damage or loss from such failures by incorporating safety design measures into your facility and equipment such as redundancy, fire protection, and prevention of over-current levels and other abnormal operating conditions.

If any products described in this document represent goods or technologies subject to certain restrictions on export under the Foreign Exchange and Foreign Trade Law of Japan, the prior authorization by Japanese government will be required for export of those products from Japan.

F0009

© FUJITSU LIMITED Printed in Japan